



ZAVOD ZA
GRADBENIŠTVO
SLOVENIJE

SLOVENIAN
NATIONAL BUILDING
AND CIVIL ENGINEERING
INSTITUTE



Member of
www.eota.eu

Dimičeva 12,
1000 Ljubljana, Slovenija

Tel.: +386 (0)1 280 44 72, +386 (0)1-280 45 37

Fax: +386 (0)1 280 44 84

e-mail: info.ta@zag.si

<http://www.zag.si>

Designated
according to
Article 26 of
Regulation (EU)
No 305/2011

European Technical Assessment

ETA-20/0940
of 14.12.2020

English version prepared by ZAG

General Part

**Technical Assessment Body issuing the
European Technical Assessment:**

ZAG Ljubljana

**Trade name of the construction
product**

FIX II HDG

**Product family to which the construction
product belongs**

33: Torque controlled expansion anchor
made of galvanised steel of sizes
M6, M8, M10, M12, M16 and M20 for
use in non-cracked concrete

Manufacturer

SPIT SAS
150 avenue de Lyon
26501 Bourg-Les-Valence, France

Manufacturing plant

Plant 1

**This European Technical Assessment
contains**

9 pages including 7 Annexes which form an
integral part of this assessment

**This European Technical Assessment is
issued in accordance with Regulation (EU) No
305/2011, on the basis of**

EAD 330232-00-0601,
edition October 2016

Translations of this European Technical Assessment in other languages shall fully correspond to the original issued document and should be identified as such.

Communication of this European Technical Assessment, including transmission by electronic means, shall be in full (excepted the confidential Annex(es) referred to above). However, partial reproduction may be made, with the written consent of the issuing Technical Assessment Body. Any partial reproduction has to be identified as such.



Specific parts

1. Technical description of the product

The FIX II HDG in the range of M6, M8, M10, M12, M16 and M20 is an anchor made of galvanised steel, which is placed into a drilled hole and anchored by torque-controlled expansion.

For the installed anchor see Figure given in Annex A1.

2. Specification of the intended use(s) in accordance with the applicable European Assessment Document (hereinafter EAD)

The performances given in Chapter 3 are only valid if the anchor is used in compliance with the specifications and conditions given in Annex B.

The provisions made in this European Technical Assessment are based on an assumed working life of the anchor of 50 years. The indications given on the working life cannot be interpreted as a guarantee given by the manufacturer, but are to be regarded only as a means for choosing the right products in relation to the expected economically reasonable working life of the works.

3. Performance of the product and references to the methods used for its assessment

3.1 Mechanical resistance and stability (BWR 1)

The basic work requirements for mechanical resistance and stability are listed in Annexes C1 and C2.

3.2 Safety in case of fire (BWR 2)

No performance determined.

3.3 General aspects relating to fitness for use

Durability and serviceability are only ensured if specifications of intended use according to Annex B1 are kept.

4. Assessment and verification of constancy of performance (hereinafter AVCP) system applied, with reference to its legal base

According to the decision 96/582/EC of the European Commission¹ the system of assessment and verification of constancy of performance (see Annex V to regulation (EU) No 305/2011) 1 apply.

5. Technical details necessary for the implementation of the AVCP system, as provided for in the applicable EAD

Technical details necessary for the implementation of the AVCP system are laid down in the control plan deposited at ZAG Ljubljana.

Issued in Ljubljana on 14. 12. 2020

Signed by:

Franc Capuder, M.Sc.

Head of Service of TAB

¹ Official Journal of the European Communities L 254 of 8.10.1996
ETA-20/0940, issued on 14. 12. 2020 – page 2 of 9

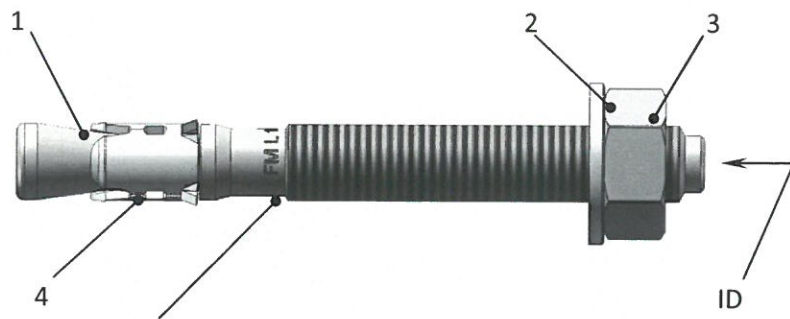

1. Anchor bolt (body)
2. Washer
3. Nut
4. Expansion sleeve

Marking: "FM" = identification of an anchor
 "R" = identification letter short length of anchor only for reduced embedment depth
 or "L" = long thread
 or "S" = short thread
 "d_{nom}" = nominal diameter of anchor
 "t_{fix}" = max thickness of fixture
 e.g.: FM L 10/20 (anchor size M10x90 - t_{fix} = 20 mm)

Figure A1: FIX II HDG anchor

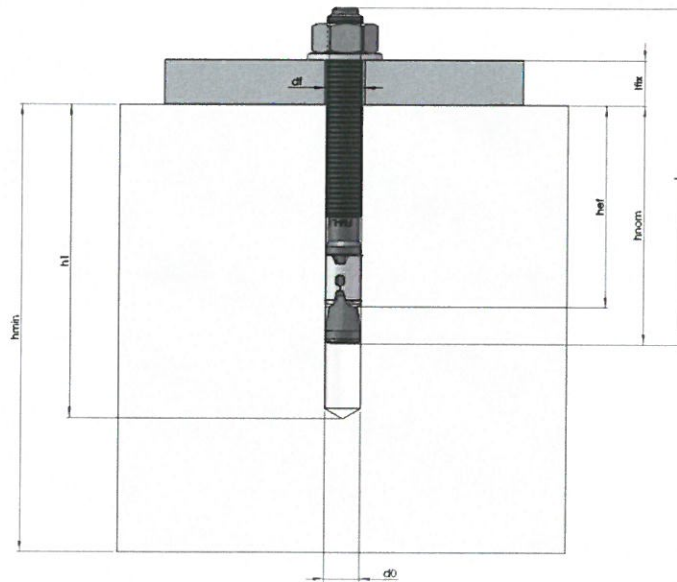
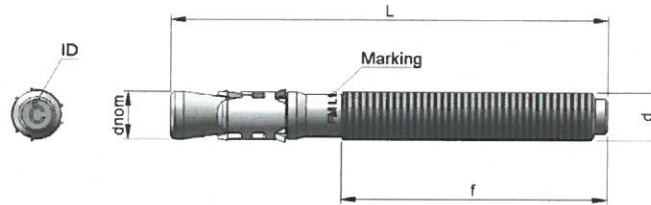

Figure A2: Installed FIX II HDG anchor

FIX II HDG	Annex A1
Product description Product and intended use	



Table A1: Dimensions



d	dxL	Marking	ID	L [mm]	d _{nom} [mm]	f [mm]
M6	M6x45	FM-R 6/3	A	47	6	20
	M6x65	FM-L 6/15	B	65		40
	M6x85	FM-L 6/35	C	85		60
	M6x100	FM-L 6/50	D	100		60
M8	M8x50	FM-R 8/5	A	53	8	22
	M8x65	FM-L 8/7	B	65		37
	M8x75	FM-L 8/15	C	75		47
	M8x90	FM-L 8/30	D	90		62
	M8x115	FM-L 8/55	E	115		82
	M8x135	FM-L 8/75	F	135		87
	M8x165	FM-L 8/105	G	165		87
M10	M10x60	FM-R 10/5	A	63	10	28
	M10x75	FM-L 10/5	B	78		43
	M10x90	FM-L 10/20	C	90		55
	M10x100	FM-L 10/30	I	100		65
	M10x120	FM-L 10/50	D	120		85
	M10x145	FM-L 10/75	E	145		85
	M10x170	FM-L 10/100	F	173		85
M12	M12x80	FM-R 12/7	A	80	12	40
	M12x100	FM-L 12/10	B	100		58
	M12x110	FM-L 12/20	C	110		68
	M12x135	FM-L 12/45	D	135		93
	M12x160	FM-L 12/70	E	160		93
	M12x185	FM-L 12/100	F	188		93
	M12x200	FM-L 12/115	G	200		93
	M12x220	FM-L 12/135	H	220		93
	M12x240	FM-L 12/155	I	240		93
	M12x255	FM-L 12/170	L	255		93
	M12x285	FM-L 12/200	M	285		93
	M12x300	FM-L 12/215	N	300		93
	M12x325	FM-L 12/240	P	325		93
M16	M16x110	FM-R 16/15	P	110	16	53
	M16x125	FM-S 16/10	A	125		68
	M16x145	FM-S 16/30	B	145		88
	M16x175	FM-S 16/60	C	175		88
	M16x215	FM-S 16/100	D	215		88
	M16x230	FM-S 16/115	E	230		88
	M16x250	FM-S 16/135	F	250		88
	M16x270	FM-S 16/155	G	270		88
	M16x285	FM-S 16/170	H	285		88
M20	M20x170	FM-S 20/30	A	170	20	65
	M20x215	FM-S 20/75	B	215		65
	M20x260	FM-S 20/120	C	260		65
	M20x280	FM-S 20/140	D	280		65

FIX II HDG

Product description
Dimensions

Annex A2



Table A1: Materials

Part	Component	Material	Coating
1	Anchor body (bolt)	Cold formed or machined steel according to EN ISO 898/1	Galvanised $\geq 10 \mu\text{m}$ "high resistance grey opaque"
2	Washer	Steel according to DIN 125/1 – 140 HV	
3	Hexagonal nut	Steel grade 8 according to DIN 934	
4	Expansion sleeve	Stainless steel AISI 316 according to EN 10088/2	

FIX II HDG

Product description
Materials

Annex A3



Specifications of intended use**Anchorage subjected to:**

- Static, quasi static load.

Base materials:

- Non-cracked concrete.
- Reinforced and unreinforced normal weight concrete of strength class C20/25 at minimum and C50/60 at maximum according to EN 206-1:2013+A1:2016.

Use conditions (Environmental conditions):

- The anchor may be used in concrete subject to dry internal conditions

Design:

- Anchorages are designed under the responsibility of an engineer experienced in anchorages and concrete work.
- Anchorages under static and quasi-static actions are designed in accordance with EOTA TR 055, Edition December 2016 or EN 1992-4:2018.
- Verifiable calculation notes and drawings are prepared taking into account of the load to be anchored. The position of the anchor is indicated on the design drawings (e.g. position of the anchor relative to reinforcement or to supports, etc.).

Installation:

- Anchor installation carried out by appropriately qualified personnel and under the supervision of the person responsible for technical matters on the site.
- Use of the anchor only as supplied by the manufacturer without exchanging the components of an anchor.
- Anchor installation in accordance with the manufacturer's specifications and drawings using the appropriate tools.
- Thickness of the fixture corresponding to the range of required thickness values for the type of anchor.
- Checks before placing the anchor to ensure that the strength class of the concrete in which the anchor is to be placed is in the range given and is not lower than that of the concrete to which the characteristic loads apply for.
- Check of concrete being well compacted, e.g. without significant voids.
- Cleaning of the hole of drilling dust.
- Anchor installation ensuring the specified embedment depth.
- Keeping of the edge distance and spacing to the specified values without minus tolerances.
- Positioning of the drill holes without damaging the reinforcement.
- In case of aborted hole: new drilling at a minimum distance away of twice the depth of the aborted hole or smaller distance if the aborted drill hole is filled with high strength mortar and if under shear or oblique tension load it is not to the anchor in the direction of load application.
- Application of the torque moment given in Annex B2 or C1 using a calibrated torque wrench.

FIX II HDG**Intended use**
Specification**Annex B1**

Table B1: Installation data

d	dxL	t_{fix} $h_{ef,RED}$ [mm]	t_{fix} $h_{ef,STD}$ [mm]	h_1 [mm]	h_{nom} [mm]	h_{ef} [mm]	d_0 [mm]	$d_{cut,max}$ [mm]	d_f [mm]	h_{min} [mm]	T_{inst} [Nm]	sw [mm]
M6	M6x45	3	-	45	36	30	6	6,45	7	100	6	10
	M6x65	(20)	15	50	41	35						
	M6x85	(40)	35									
	M6x100	(55)	50									
M8	M8x50	5	-	50	38	30	8	8,45	9	100	15	13
	M8x65	(15)	7	60	48	40						
	M8x75	(25)	15									
	M8x90	(40)	30									
	M8x115	(65)	55									
	M8x135	(85)	75									
	M8x165	(115)	105									
M10	M10x60	5	-	55	44	35	10	10,45	12	100	25	17
	M10x75	(20)	5	70	59	50						
	M10x90	(35)	20									
	M10x100	(45)	30									
	M10x120	(65)	50									
	M10x145	(90)	75									
	M10x170	(115)	100									
M10x210	(155)	140										
M12	M12x80	7	-	70	56	45	12	12,5	14	100	50	19
	M12x100	(25)	10	85	71	60				120		
	M12x110	(35)	20									
	M12x135	(60)	45									
	M12x160	(85)	70									
	M12x185	(115)	100									
	M12x200	(130)	115									
	M12x220	(150)	135									
	M12x240	(170)	155									
	M12x255	(185)	170									
	M12x285	(215)	200									
	M12x300	(230)	215									
	M12x325	(255)	240									
M12x355	(285)	270										
M16	M16x110	15	-	95	76	65	16	16,5	18	130	100	24
	M16x125	(30)	10	115	96	85				170		
	M16x145	(50)	30									
	M16x175	(80)	60									
	M16x215	(120)	100									
	M16x230	(135)	115									
	M16x250	(155)	135									
	M16x270	(175)	155									
	M16x285	(190)	170									
M16x320	(225)	205										
M20	M20x170	-	30	130	115	95	20	20,5	22	200	150	30
	M20x215	-	75									
	M20x260	-	120									
	M20x280	-	140									

(..) = t_{fix} by reduced embedment depth $h_{ef,RED}$

FIX II HDG

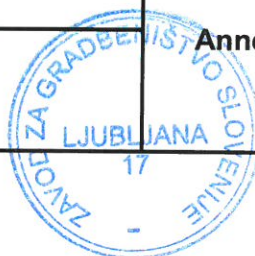
Intended use
Installation data

Annex B2



Table C1: **Characteristic values for Tension loads in case of static and quasi-static loading for design method A acc. EOTA TR 055 or EN 1992-4**

Essential characteristics			Performance										
			M6-1	M6-2	M8-1	M8-2	M10-1	M10-2	M12-1	M12-2	M16-1	M16-2	M20
Installation parameters													
d₀	Nominal diameter of drill bit	[mm]	6		8		10		12		16		20
h_{ef}	Effective anchorage depth	[mm]	30*	35*	30*	40	35*	50	45	60	65	85	95
h_{min}	Minimum thickness of concrete member	[mm]	100		100		100		100	120	130	170	200
T_{inst}	Torque moment	[Nm]	6		15		25		50		100		150
s_{min}	Minimum spacing	[mm]	45	50	45	55	50	55	120	90	140	130	200
c_{min}	Minimum edge distance	[mm]	45	50	45	55	50	55	80	90	100	130	145
Tension steel failure mode													
N_{Rk,s}	Characteristic tension steel failure	[kN]	11		17		28		33		72		108
γ_{Ms,N}	Partial safety factor	[-]	1,5		1,4		1,4		1,4		1,5		1,5
Pull-out failure mode													
N_{Rk,p}	Characteristic pull-out failure in non-cracked concrete	[kN]	5	6	6	12	6	12	12	..1)	..1)	35	40
γ₂	Partial safety factor	[-]	1,0										
γ_{Mp}		[-]	1,5										
s_{cr,N}	Characteristic spacing	[mm]	3 × h _{ef}										
c_{cr,N}	Characteristic edge distance	[mm]	1,5 × h _{ef}										
ψ_{C,C30/37}	Increasing factor for	[-]	1,09				1,13				1,22		
ψ_{C,C40/50}	N _{Rk,p} in non-cracked concrete	[-]	1,15				1,23				1,41		
ψ_{C,C50/60}		[-]	1,22				1,33				1,58		
Concrete Cone failure mode													
k_{ucr}	Factor for non-cracked concrete EN 1992-4 §. 7.2.1.4	[-]	11,0										
γ_{Mc}	Partial safety factor	[-]	1,5										
Splitting failure mode													
s_{cr,sp}	Characteristic spacing	[mm]	3 × h _{ef}										
c_{cr,sp}	Characteristic edge distance	[mm]	1,5 × h _{ef}										
γ_{Msp}	Partial safety factor	[-]	1,5										
Displacement under tension load													
Non-cracked concrete C20/25													
N	Service tension load	[kN]	2,4	2,9	2,9	5,7	2,9	5,7	5,7	11,2	12,6	16,7	19,0
δ_{N0}	Short term displacement	[mm]	0,21	0,33	0,09	1,6	0,07	0,35	0,10	0,12	0,03	0,03	0,05
δ_{N∞}	Long term displacement	[mm]	1,6	1,6	1,6	1,6	1,6	1,6	1,6	1,6	1,6	1,6	1,6

* Use restricted to anchoring of structural components statically indeterminated

¹⁾ Pull – through failure is not decisive

FIX II HDG

Design acc. to EOTA TR 055 or EN 1992-4

Characteristic resistance under Tension loads –
BWR 1

Annex C1

Table C2: **Characteristic values for shear loads in case of static and quasi-static loading for design method A acc. EOTA TR 055 or EN 1992-4**

Essential characteristics			Performance											
			M6-1	M6-2	M8-1	M8-2	M10-1	M10-2	M12-1	M12-2	M16-1	M16-2	M20	
Shear steel failure														
$V_{Rk,s}$	Characteristic shear steel failure	[kN]	6,5		9,2		13,9		20,1		42,6		51,5	
$M_{Rk,s}^0$	Bending moment characteristic failure	[Nm]	12		24		49		72		193		338	
k_7	Factor considering ductility	[-]	0,8											
γ_{MsV}	Partial safety factor	[-]	1,5											
Shear concrete pry-out and edge failure														
k_8	Factor in equations of EN 1992-4 § 7.2.2.4	[mm]	1,0						2,0					
l_{ef}	Effective anchorage depth	[mm]	30	35	30	40	35	50	45	60	65	85	95	
d_{nom}	Diameter of anchor	[mm]	6		8		10		12		16		20	
γ_{Mc}	Partial safety factor	[-]	1,5											
Displacement under shear load														
V	Service shear load	[kN]	3,1		4,4		6,6		9,6		20,3		24,5	
δ_{v0}	Short term displacement	[mm]	2,1		2,0		2,6		2,8		3,0		2,6	
$\delta_{v\infty}$	Long term displacement	[mm]	3,1		3,1		3,9		4,2		4,4		4,0	

FIX II HDG

Design acc. to EOTA TR 055 or EN 1992-4
 Characteristic resistance under Shear loads –
 BWR 1

Annex C2

