

Saddle flange SF Clix 31

The pre-assembled saddle flange SF Clix 31

2b



Channel installation at the wall

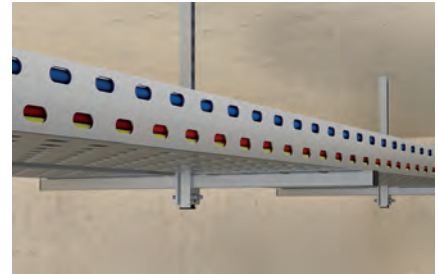

Suspended cable tray fixing

Applications

Element for the stable construction of connections between channels and building structures.

Advantages/Benefits

- Pre-assembled accessories like SF Clix bring the number of articles for a connection down and guarantee a time-saving installation.
- The pre-assembled connector of the SF Clix secures the installation position due to the unique thrust block and guarantees a safe and fast installation.
- The special spring leg at pre-assembled connector guarantees the necessary contact pressure of the connector to the channel to help for a secure adjustment during installation.
- The perfect-fit saddle of the SF allows an simple installation by inserting the channel.
- The saddle flange's stable design offers a secure hold for a load-bearing construction.

Properties

- Material saddle: steel E295 (material no.: 1.0050) acc. DIN EN 10025-2
- Material channel nut: steel S420MC (material no.: 1.0980) acc. DIN EN 10149-2
- Material cover plate: steel S235JR+CR (material no.: 1.0037) acc. DIN 1652
- Material hexagonal screw: steel min. 4.6 (DIN EN ISO 898-1)
- Material plastic cage: polypropylene PP, item number 11400, Color black
- Zinc plating: electro zinc-plated, min. 5 µm, hexagonal screw min. 3 µm acc. DIN EN ISO 4042

Installation SF Clix 31

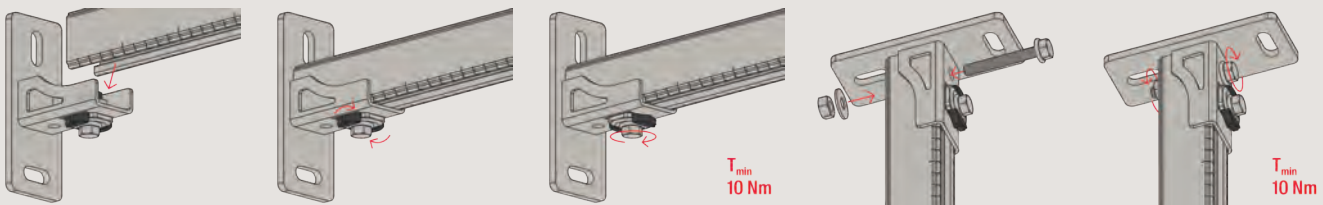

Technical data

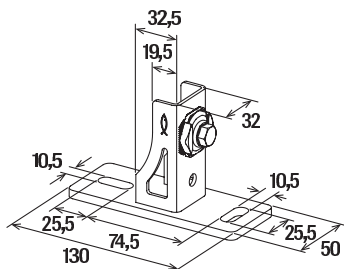

SF Clix 31

Item	Item No.	Thread A	Width across nut SW [mm]	Sales unit [pcs]
SF Clix 31	538665	M 8	13	10

2b

Loads

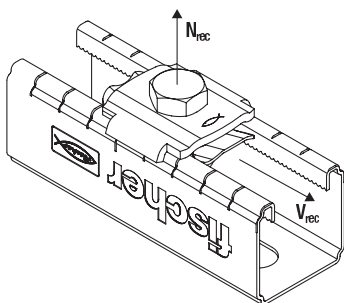

SF Clix 31

Item	Item No.	Max. recommended tension load for FLS 17/1.0 and FLS 30/1.0 N_{rec} [kN]	Max. recommended tension load for FLS 37/1.2 N_{rec} [kN]	Max. recommended shear load V_{rec} [kN]	Tightening torque T_{inst} [Nm]
SF Clix 31	538665	1.5	2.0	1.0	10