



INSTYTUT TECHNIKI BUDOWLANEJ
PL 00-611 WARSZAWA
ul. Filtrowa 1
tel.: (+48 22) 825-04-71
(+48 22) 825-76-55
fax: (+48 22) 825-52-86
www.itb.pl



Member of



www.eota.eu

European Technical Assessment

**ETA-15/0368
of 12/06/2015**

General Part

Technical Assessment Body issuing the European Technical Assessment	Instytut Techniki Budowlanej
Trade name of the construction product	SPIT TAPCON 4
Product family to which the construction product belongs	Concrete screw made of zinc plated steel of sizes 8, 10, 12 and 14 for use in concrete
Manufacturer	Société Spit 150 Route de Lyon, 26501 Bourg-Les-Valance France
Manufacturing plant	ITW Construction Products ApS Plant 1
This European Technical Assessment contains	13 pages including 3 Annexes which form an integral part of this assessment
This European Technical Assessment is issued in accordance with Regulation (EU) No 305/2011, on the basis of	Guideline for European Technical Approval ETAG 001, Edition April 2013 "Metal anchors for use in concrete – Part 1: Anchors in general and Part 3: Undercut anchors", used as European Assessment Document (EAD)

This European Technical Assessment is issued by the Technical Assessment Body in its official language. Translations of this European Technical Assessment in other languages shall fully correspond to the original issued document and should be identified as such.

Communication of this European Technical Assessment, including transmission by electronic means, shall be in full. However, partial reproduction may be made, with the written consent of the issuing Technical Assessment Body. Any partial reproduction has to be identified as such.

Specific Part

1 Technical description of the product

The concrete screw SPIT TAPCON 4 of the sizes 8, 10, 12 and 14 is made of heat treated and zinc plated steel (electroplated or mechanically deposited). The anchor is screwed into a predrilled cylindrical drill hole. The special thread of the anchor cuts an internal thread into a concrete member while setting. The anchorage is characterized by mechanical interlock in the special thread.

The description of the product is given in Annex A1 to A2.

2 Specification of the intended use in accordance with the applicable European Assessment Document (EAD)

The performances given in Section 3 are only valid if the anchors are used in compliance with the specifications and conditions given in Annex B1 to B3.

The performances given in this European Technical Assessment are based on an assumed working life of the anchor of 50 years. The indications given on the working life cannot be interpreted as a guarantee given by the producer or the Technical Assessment Body, but are to be regarded only as a means for choosing the right products in relation to the expected economically reasonable working life of the works.

3 Performance of the product and references to the methods used for its assessment

3.1 Performance of the product

3.1.1 Mechanical resistance and stability (BWR 1)

Essential characteristics	Performances
Characteristic resistance for tension loads	See Annex C1
Edge distances and spacing	See Annex C1
Displacements under tension loads	See Annex C1
Characteristic resistance for shear loads	See Annex C2
Characteristic resistance for bending moments	See Annex C2
Displacements under shear loads	See Annex C2

3.1.2 Safety in case of fire (BWR 2)

Essential characteristics	Performances
Reaction to fire	Anchors satisfy requirements for Class A1
Resistance to fire	See Annexes C3 and C4

3.1.3 Hygiene, health and the environment (BWR 3)

Regarding the dangerous substances clauses contained in this European Technical Assessment, there may be requirements applicable to the products falling within its scope (e.g. transposed European legislation and national laws, regulations and administrative provisions). In order to meet the provisions of the Construction Products Regulation, these requirements need also to be complied with, when and where they apply.

3.1.4 Safety in use (BWR 4)

For Basic Requirement Safety in use the same criteria are valid as for Basic Requirement Mechanical resistance and stability (BWR 1).

3.1.5 Sustainable use of natural resources (BWR 7)

No performance assessed.

3.1.6 General aspects relating to fitness for use

Durability and serviceability are only ensured if the specifications of intended use according to Annex B1 are kept.

3.2 Methods used for the assessment

The assessment of fitness of the anchors for the intended use in relation to the requirements for mechanical resistance and stability and safety in use in the sense of the Basic Requirements 1 and 4 has been made in accordance with the ETAG 001 "Metal anchors for use in concrete", Part 1: "Anchors in general" and Part 3: "Undercut anchors", on the basis of Option 1.

4 Assessment and verification of constancy of performance (AVCP) system applied, with reference to its legal base

According to Decision 96/582/EC of the European Commission the system of assessment and verification of constancy of performance (see Annex V to Regulation (EU) No 305/2011) given in the following table apply.

Product	Intended use	Level or class	System
Metal anchors for use in concrete	For fixing and/or supporting to concrete structural elements (which contributes to the stability of the works) or heavy units	-	1

5 Technical details necessary for the implementation of the AVCP system, as provided for in the applicable European Assessment Document (EAD)

Technical details necessary for the implementation of the AVCP system are laid down in the Control Plan which is deposited at Instytut Techniki Budowlanej.

For type testing the results of the tests performed as part of the assessment for the European Technical Assessment shall be used unless there are changes in the production line or plant. In such cases the necessary type testing has to be agreed between Instytut Techniki Budowlanej and the notified body.

Issued in Warsaw on 12/06/2015 by Instytut Techniki Budowlanej

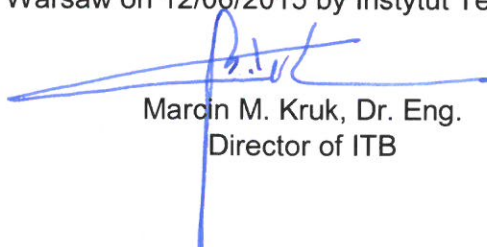

Marcin M. Kruk, Dr. Eng.
Director of ITB

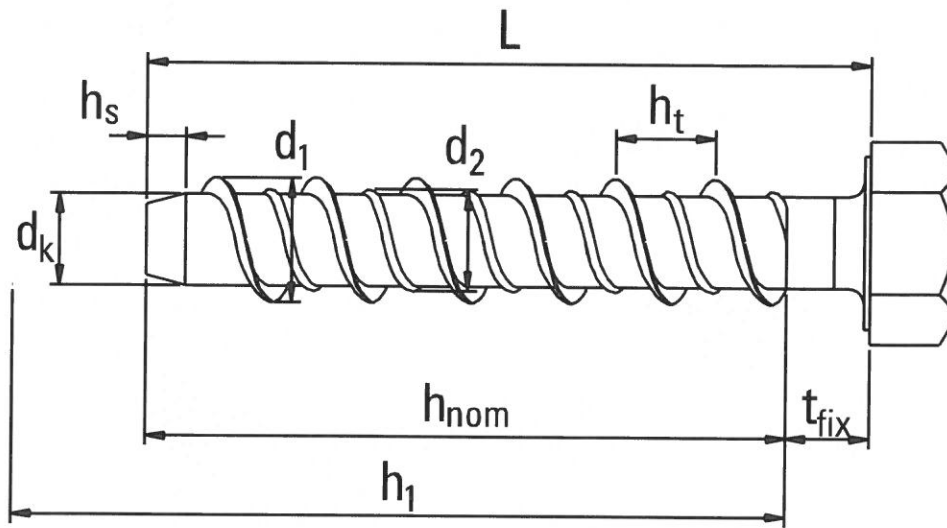

<p style="text-align: center;">SPIT TAPCON 4</p>	<p style="text-align: center;">Annex A1 of European Technical Assessment ETA-15/0368</p>
<p style="text-align: center;">Product description Characteristic of the product</p>	

Table A1: Dimensions and materials

Anchor size			8	10	12	14
Length of anchor L	L _{min}	mm	50	55	55	65
	L _{max}	mm	250	350	350	350
Bolt diameter Ød _k		mm	7.50	9.37	11.35	13.20
Higher thread diameter Ød ₁		mm	9.85	11.95	14.08	16.23
Lower thread diameter Ød ₂		mm	8.13	10.25	12.15	14.18
Thread pitch h _t		mm	10	12	12	17
h _s		mm	5	5	5	5
Materials			Steel 10B21 acc. to SAE-J403 Zinc coating (≥ 5 µm); electroplated acc. to EN ISO 4042 or mechanically deposited acc. to EN ISO 12683			

Table A2: Head types with marking

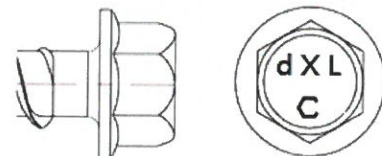
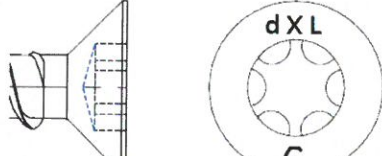
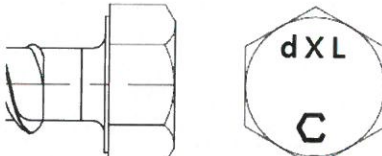
Hex Flange Head	Countersunk Torx Head	Hex Head
		
<p>Marking: Identifying mark of the producer: C d X L where: d = anchor size [mm] e.g. 8 L = length of anchor [mm] e.g. 100</p>	<p>Marking: Identifying mark of the producer: C d X L where: d = anchor size [mm] e.g. 10 L = length of anchor [mm] e.g. 120</p>	<p>Marking: Identifying mark of the producer: C d X L where: d = anchor size [mm] e.g. 12 L = length of anchor [mm] e.g. 130</p>

SPIT TAPCON 4

Product description
Dimensions, materials and head types

Annex A2
of European
Technical Assessment
ETA-15/0368

SPECIFICATION OF INTENDED USE

Anchorage subject to:

- Static and quasi-static loads: sizes from 8 to 14.
- Fire exposure: sizes from 8 to 14.

Base material:

- Reinforced or unreinforced normal weight concrete of strength class C20/25 at minimum to C50/60 at maximum according to EN 206.
- Non cracked concrete: sizes from 8 to 14.
- Cracked concrete: sizes from 8 to 14.

Use conditions (environmental conditions):

- Structures subject to dry internal conditions.

Design:

- Anchorages are designed under the responsibility of an engineer experienced in anchorages and concrete work.
- Verifiable calculation notes and drawings are prepared taking account of the loads to be transmitted. The position of the anchor is indicated on the design drawings (e.g. position of the anchor relative to reinforcement or to supports, etc.).
- Anchorages under static and quasi-static loads are designed in accordance with ETAG 001, Annex C, design method A.
- Anchorages under fire exposure are designed in accordance with EOTA Technical Report TR 020.

Installation:

- Anchor installation carried out by appropriately qualified personnel and under the supervision of the person responsible for technical matters of the site.
- Anchor installation in accordance with the manufacturer's specifications and drawings and using the appropriate tools.
- Check of concrete being well compacted, e.g. without significant voids.
- Positioning of the drill holes without damaging the reinforcement.
- Anchor installation such that the effective anchorage depth is complied with.

SPIT TAPCON 4	Annex B1 of European Technical Assessment ETA-15/0368
Intended use Specification	

Table B1: Installation parameters

Anchor size			8			10			12			14		
Nominal drill bit diameter	d_0	mm	8			10			12			14		
Cutting diameter of drill bit	$d_{cut} \leq$	mm	8.45			10.45			12.50			14.50		
Depth of drill hole	$h_1 \geq$	mm	55	60	75	60	70	85	60	70	105	70	80	125
Nominal anchorage depth	h_{nom}	mm	45	50	65	50	60	75	50	60	95	60	70	115
Clearance hole in the fixture	d_f	mm	12			14			16			18		

Table B2: Minimum thickness of concrete member, minimum spacing and minimum edge distance

Anchor size			8		10		12		14	
Minimum thickness of member	h_{min}	mm	110		110		130		150	
Minimum edge distance	c_{min}	mm	60		70		80		90	
Minimum spacing	s_{min}	mm	60		70		80		90	

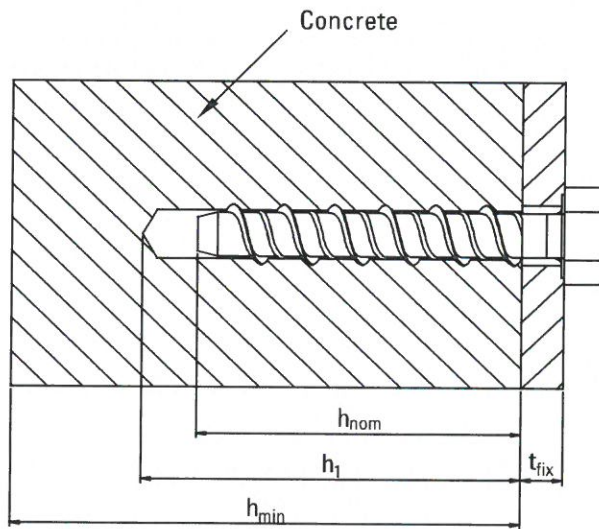

SPIT TAPCON 4

Intended use
Installation parameters

Annex B2
of European
Technical Assessment
ETA-15/0368

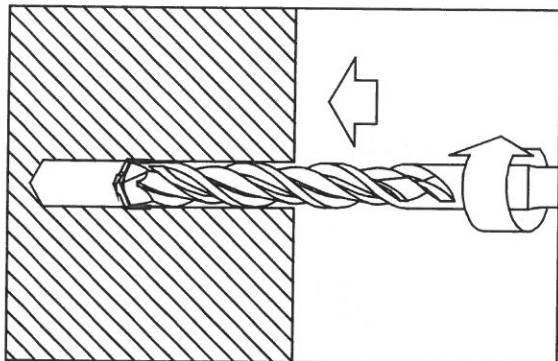

Drill hole with rotary percussive machine. Drill to a required depth.

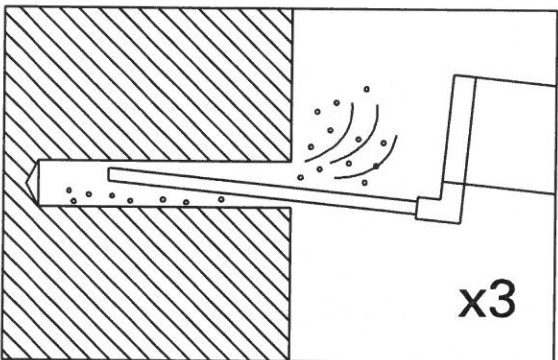

Blow out dust at least 3 times with a hand pump.

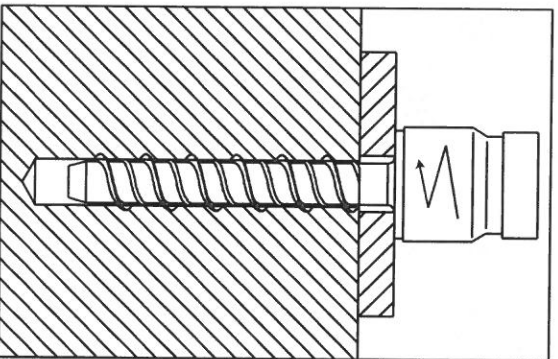

Screw the anchor with suitable impact screw driver (BOSCH GDS 18 E¹).

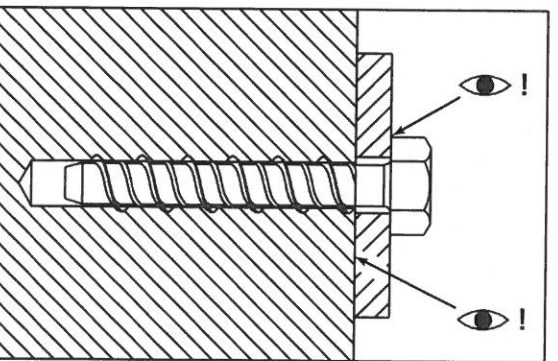

The fixture shall be fully pressed on the concrete surface without intermediate layers. Further turning of the anchor is not possible. The head of the anchor has to be fully supported on the fixture and is not damaged.

¹ installation with other impact screw driver of equivalent power and performance is possible

SPIT TAPCON 4

Intended use
Installation instruction

Annex B3
of European
Technical Assessment
ETA-15/0368

Table C1: Characteristic resistance for tension loads in cracked and non-cracked concrete C20/25 to C50/60 (design acc. to ETAG 001, Annex C, design method A)

Anchor size		8			10			12			14		
Nominal anchorage depth	h_{nom} [mm]	45	50	65	50	60	75	50	60	95	60	70	115
Steel failure													
Characteristic resistance	$N_{Rk,s}$ [kN]	42,4			67,2			99,4			134,0		
Partial safety factor	γ_{Ms} ¹⁾	1,4											
Pullout failure													
Characteristic resistance in non-cracked concrete C20/25	$N_{Rk,p}$ [kN]	6	6	12	6	9	16	6	9	25	9	12	35
Characteristic resistance in cracked concrete C20/25	$N_{Rk,p}$ [kN]	3	4	7,5	4	6	9	4	6	16	5	7,5	20
Increasing factors for $N_{Rk,p}$	Ψ_c C30/37	1,17			1,17			1,17			1,22		
	C40/50	1,32			1,32			1,32			1,41		
	C50/60	1,42			1,42			1,42			1,55		
Partial safety factor for cracked and non-cracked concrete	γ_{Mp} ¹⁾	1,8											
Concrete cone and splitting failure													
Effective anchorage depth	h_{ef} [mm]	30	34	47	33	42	54	33	42	71	40	48	86
Spacing	$s_{cr,N}$ [mm]	90	102	141	100	124	162	100	124	213	118	144	258
Edge distance	$c_{cr,N}$ [mm]	45	51	71	50	62	81	50	62	107	59	72	129
Spacing	$s_{cr,sp}$ [mm]	90	102	141	100	124	162	100	124	213	118	144	258
Edge distance	$c_{cr,sp}$ [mm]	45	51	71	50	62	81	50	62	107	59	72	129

¹⁾ in the absence of other national regulations

Table C2: Displacements under tension loads

Anchor size			8		10		12		14	
Non-cracked concrete C20/25 to C50/60	Tension load	N [kN]	5,8		8,5		12,6		15,6	
	Displacement	δ_{NO} [mm]	0,3		0,4		0,4		0,6	
		δ_{Nc} [mm]	1,4		1,5		1,8		1,9	
Cracked concrete C20/25 to C50/60	Tension load	N [kN]	3,2		4,0		6,9		9,6	
	Displacement	δ_{NO} [mm]	0,4		0,5		0,5		0,6	
		δ_{Nc} [mm]	2,0		2,0		2,0		2,0	

SPIT TAPCON 4

Performances
Characteristic resistance for tension loads. Displacements

Annex C1
of European
Technical Assessment
ETA-15/0368

Table C3: Characteristic resistance for shear loads in cracked and non-cracked concrete C20/25 to C50/60 (design acc. to ETAG 001, Annex C, design method A)

Anchor size		8			10			12			14		
Nominal anchorage depth	h_{nom} [mm]	45	50	65	50	60	75	50	60	95	60	70	115
Steel failure without lever arm													
Characteristic resistance	$V_{Rk,s}$ [kN]	17,0			26,9			39,8			53,5		
Partial safety factor	$\gamma_{Ms}^{1)}$	1,5											
Steel failure with lever arm													
Characteristic bending resistance	$M_{Rk,s}^0$ [Nm]	46,8			93,2			167,7			261,8		
Partial safety factor	$\gamma_{Ms}^{1)}$	1,5											
Concrete pryout failure													
Factor in equation (5.6) of ETAG 001 Annex C, 5.2.3.3	k	1,0						2,0					
Concrete edge failure													
Effective length of anchor	l_f [mm]	30	34	47	33	42	54	33	42	71	40	48	86
Effective diameter of anchor	d_{nom} [mm]	8			10			12			16		
Partial safety factor	$\gamma_{Mc}^{1)}$	1,5											

¹⁾ in the absence of other national regulations

Table C4: Displacements under shear loads

Anchor size			8			10			12			14		
Non-cracked and cracked concrete C20/25 to C50/60	Shear load	V [kN]	6,9			11			15			15,5		
	Displacement	δ_{v0} [mm]	1,5			1,7			2,0			2,7		
		$\delta_{v\infty}$ [mm]	2,3			2,6			3,0			4,1		

SPIT TAPCON 4

Performances
Characteristic resistance for shear loads. Displacements

Annex C2
of European
Technical Assessment
ETA-15/0368

Table C5: Characteristic resistance for tension loads under fire exposure in cracked and non-cracked concrete C20/25 to C50/60 (acc. to TR 020)

Anchor size			8	10	12	14
Nominal anchorage depth	h_{nom} [mm]		65	75	95	115
Steel failure						
Characteristic resistance	R30	$N_{Rk,s,fi}$ [kN]	0,64	1,34	1,99	2,68
	R60	$N_{Rk,s,fi}$ [kN]	0,55	1,01	1,49	2,01
	R90	$N_{Rk,s,fi}$ [kN]	0,42	0,87	1,29	1,74
	R120	$N_{Rk,s,fi}$ [kN]	0,34	0,67	0,99	1,34
Pullout failure						
Characteristic resistance	R30	$N_{Rk,p,fi}$ [kN]	1,9	2,2	4,0	5,0
	R60	$N_{Rk,p,fi}$ [kN]	1,9	2,2	4,0	5,0
	R90	$N_{Rk,p,fi}$ [kN]	1,9	2,2	4,0	5,0
	R120	$N_{Rk,p,fi}$ [kN]	1,5	1,8	3,2	4,0
Concrete cone failure						
Characteristic resistance	R30	$N_{Rk,c,fi}$ [kN]	2,7	3,9	7,6	12,3
	R60	$N_{Rk,c,fi}$ [kN]	2,7	3,9	7,6	12,3
	R90	$N_{Rk,c,fi}$ [kN]	2,7	3,9	7,6	12,3
	R120	$N_{Rk,c,fi}$ [kN]	2,2	3,1	6,1	9,9
Edge distance						
	R30	$c_{cr,N,fi}$ [mm]	$2 \cdot h_{ef}$			
	R60	$c_{cr,N,fi}$ [mm]				
	R90	$c_{cr,N,fi}$ [mm]				
	R120	$c_{cr,N,fi}$ [mm]				
Spacing						
	R30	$s_{cr,N,fi}$ [mm]	$4 \cdot h_{ef}$			
	R60	$s_{cr,N,fi}$ [mm]				
	R90	$s_{cr,N,fi}$ [mm]				
	R120	$s_{cr,N,fi}$ [mm]				
SPIT TAPCON 4						Annex C3 of European Technical Assessment ETA-15/0368
Performances Characteristic resistance for tension loads under fire exposure						

Table C6: Characteristic resistance for shear loads under fire exposure in cracked and non-cracked concrete C20/25 to C50/60 (acc. to TR 020)

Anchor size		8	10	12	14	
Nominal anchorage depth	h_{nom} [mm]	65	75	95	115	
Steel failure without lever arm						
Characteristic resistance	R30	$V_{Rk,s,fi}$ [kN]	0,64	1,34	1,99	2,68
	R60	$V_{Rk,s,fi}$ [kN]	0,55	1,01	1,49	2,01
	R90	$V_{Rk,s,fi}$ [kN]	0,42	0,87	1,29	1,74
	R120	$V_{Rk,s,fi}$ [kN]	0,34	0,67	0,99	1,34
Steel failure with lever arm						
Characteristic bending resistance	R30	$M^0_{Rk,s,fi}$ [Nm]	0,70	1,86	3,36	5,24
	R60	$M^0_{Rk,s,fi}$ [Nm]	0,61	1,40	2,52	3,93
	R90	$M^0_{Rk,s,fi}$ [Nm]	0,47	1,21	2,18	3,40
	R120	$M^0_{Rk,s,fi}$ [Nm]	0,37	0,93	1,68	2,62
Concrete pry-out failure						
	R30	k [-]	1	1	2	2
	R60	k [-]				
	R90	k [-]				
	R120	k [-]				
Concrete edge failure						
	R30	$V^0_{Rk,c,fi}$ [kN]	0,25 · $V^0_{Rk,c}$			
	R60	$V^0_{Rk,c,fi}$ [kN]				
	R90	$V^0_{Rk,c,fi}$ [kN]				
	R120	$V^0_{Rk,c,fi}$ [kN]	0,20 · $V^0_{Rk,c}$			
* $V^0_{Rk,c}$ - initial value of the characteristic resistance in cracked concrete C20/25 under normal temperature acc. to ETAG 001, Annex C						

SPIT TAPCON 4

Performances
Characteristic resistance for shear loads under fire exposure

Annex C4
of European
Technical Assessment
ETA-15/0368