

Project: 20046 /15515
Report on fire evaluation of post installed rebar connections with fischer FIS V Plus / FIS V Plus Low Speed injection system

Client: fischerwerke GmbH & Co. KG
Denzlingen, Germany

Author: Heiner Kruse

Date: 26.11.2020



apl. Prof. Dr.-Ing. Catherina Thiele



Heiner Kruse M.Sc.

Table of contents

1. General	3
2. The evaluated elements	3
3. Design method	3
4. Simulation input	5
5. Structural connections	7
6. Simulation results	9
6.1. Maximum applicable bond stress for slab-slab connections	9
6.2. Maximum applicable loads for beam-wall connections	11
6.2.1. Maximum applicable loads for a beam-wall connection with a concrete cover of 10mm	12
6.2.2. Maximum applicable loads for a beam-wall connection with a concrete cover of 20mm	14
6.2.3. Maximum applicable loads for a beam-wall connection with a concrete cover of 30mm	20
6.2.4. Maximum applicable loads for a beam-wall connection with a concrete cover of 40mm	28
6.2.5. Maximum applicable loads for a beam-wall connection with a concrete cover of 55mm	36
7. References	44

1. General

The Technical University of Kaiserslautern had been authorized by the company fischerwerke GmbH & Co. KG to generate a fire evaluation for post-installed rebars using the FIS V Plus / FIS V Plus Low Speed injection system. The following document is based on the test results of the test report 18049HK15563 [1] and the expertise "Project 20037HK/15511_3" [7].

2. The evaluated elements

Several bar diameters from \varnothing 8 to 28 mm with anchorage depths between 100 and 1210 mm in C20/25 concrete are opposed to fire and evaluated. For anchoring depths up to 2000 mm the simulation values of 1210 mm can be used. Considered are two structural systems: the slab-slab connection and the beam-wall connection.

The following is to be calculated:

- Maximal applicable bond stress to be used in case of the slab-slab connection,
- Maximal applicable bond load to be used in case of the beam-wall connection.

3. Design method

The design method consists of four steps (represented in figure 1). First, determining a reduction factor $K_N(\theta)$ [1], which describes the proportion between bond resistance and temperature, based on pullout tests at various temperatures. Secondly, a thermal simulation using the Finite Elements method is carried out to determine the temperature figure along the rebar at certain time T during a fire. Thirdly, the bond resistances in case of fire are estimated using the first two steps. A fourth step, in case of the beam-wall connection, is the calculation of the characteristic maximal load by integration of the bond resistance. Thermal simulations, geometrics considerations and safety coefficients are determined in accordance with Eurocode and standards [2] [3] [4]

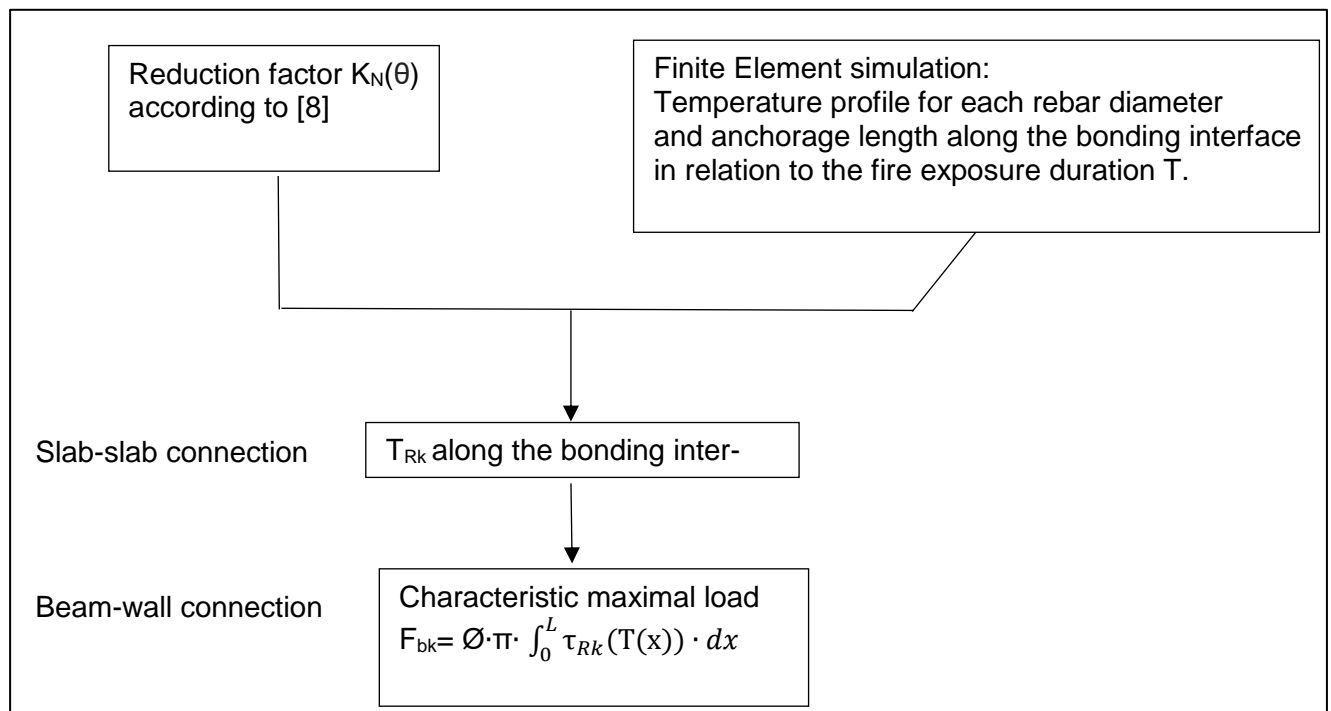

Figure 1: Method to determine the applicable loads in fire conditions

Where:

f_{TRK} : the characteristic bonding resistance [N/mm²].

T : the temperature [°].

F_{bk} : the characteristic maximum load applicable to the rebar at a given time [N].

L : the embedment length [mm].

\varnothing : the rebar diameter [mm].

In figure 2 the relationship between temperature and temperature reduction factor is described. [1]

Reduction factor $k_N(\theta)$ for design in case of fire

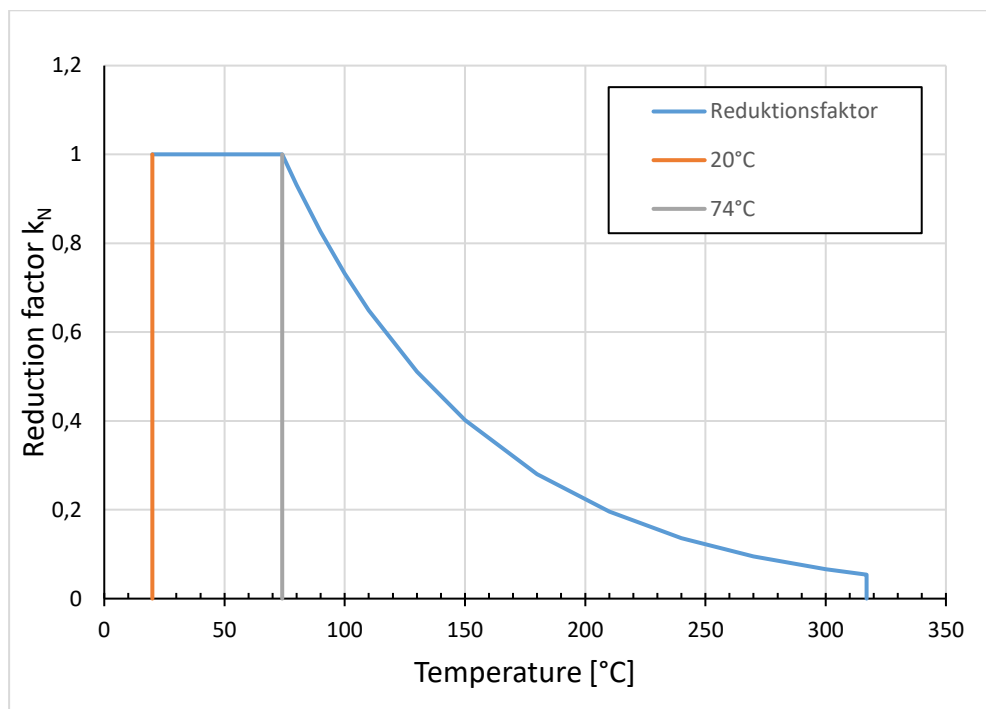

$$20^{\circ}\text{C} \leq \theta \leq 74^{\circ}\text{C}$$

$$k_N = 1$$

$$75^{\circ}\text{C} \leq \theta \leq 317^{\circ}\text{C}$$

$$k_N = \frac{24,308 * e^{-0,012 * \theta}}{10}$$

$$\theta > 317^{\circ}\text{C}$$

$$k_N = 0$$

Figure 2: Relationship between temperature and the reduction factor

This report uses the characteristic values of bond strength. Accordingly, the values of bond resistance and load resistance in case of fire are given as characteristic values.

4. Simulation input

The simulations were performed with Ansys Workbench and the simulated model consists of two materials:

- Properties of concrete

Concrete: C20/25 with characteristic value of ultimate bond resistance

$$f_{bk} = f_{bd} \times \gamma_c = 2,3 \times 1,5 = 3,45 \text{ N/mm}^2$$

Where:

f_{bd} : the design value of the ultimate bond resistance for C20/25 according to [5]

γ_c : is the safety factor for concrete according to [5]

Thermal properties of concrete which are used in these simulations are provided are based on DIN EN 1992-1-2 (+NA) [2], where the thermal properties of steel are based on DIN EN 1993-1-2 (+NA) [3]

The characteristic courses of the thermal conductivity, mass density and the specific heat are represented below.

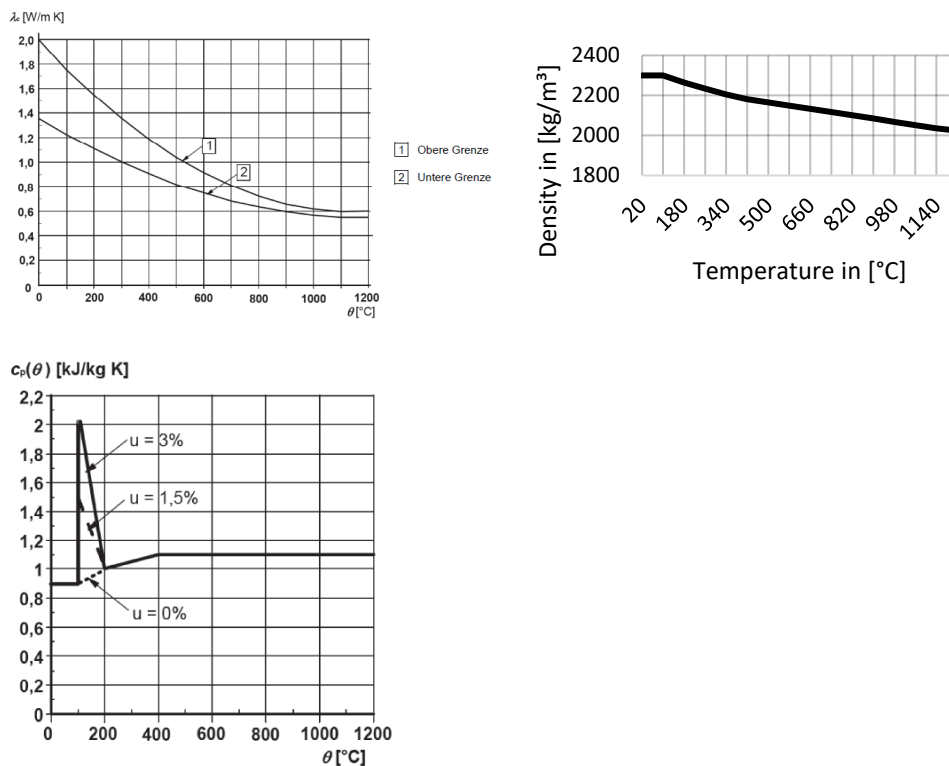
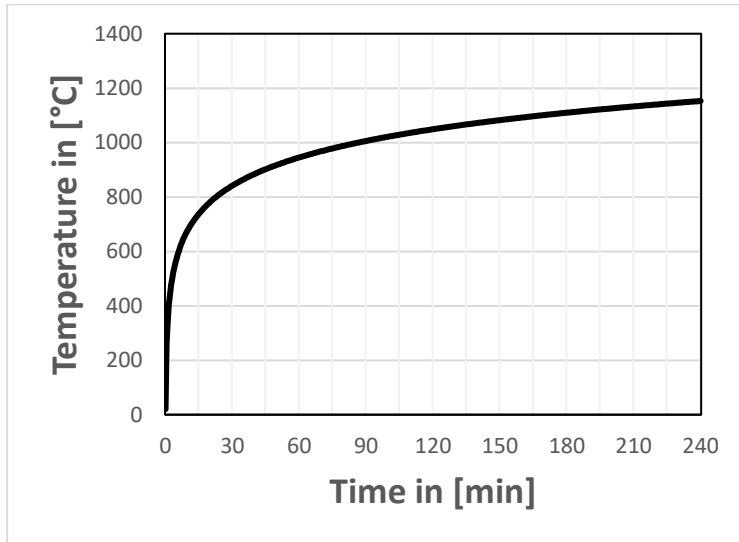

Figure 3: Variations of the thermal conductivity, density and specific heat of concrete provided by DIN EN 1992-1-2 [2].

Steel bars: with a yield strength $f_y = 500 \text{ N/mm}^2$ according to [5]

- Fire load

This model is exposed to a fire defined by the standard temperature curve as reference DIN ISO 834-1 [6].



$$\theta_g = 20 + 345 \log_{10}(8t + 1)$$

θ_g the gas temperature
 t the time in minutes

Figure 4: the standard temperature curve according to [6]

5. Structural connections

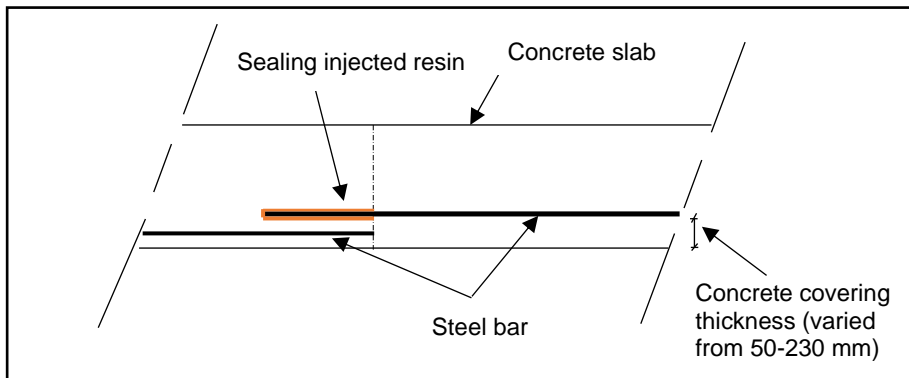

Figure 5: Slab-slab connection

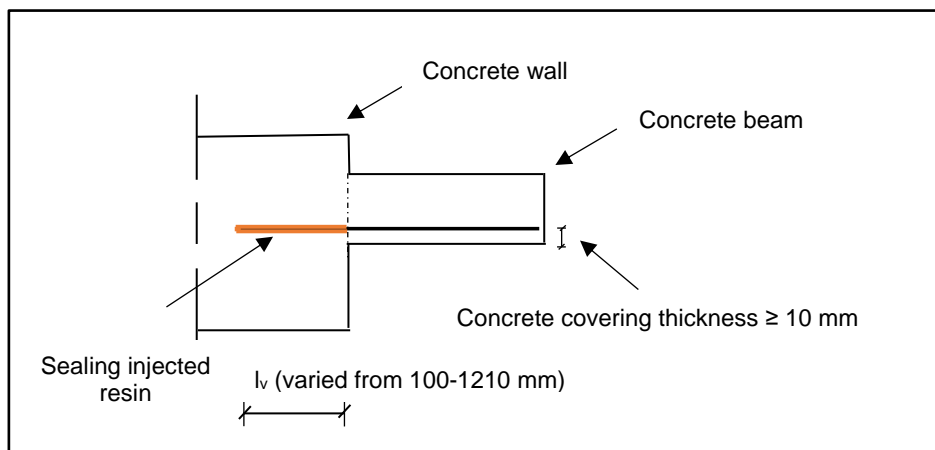

Figure 6: beam-wall connection

For the beam-wall connection, the temperature of the edge bar was used for the evaluation and therefore the results can also be applied to a slab-wall connection

This figures present the temperature profiles of the Beam-wall connection at 30, 120 and 240 min. All temperature values are shown in [°C].

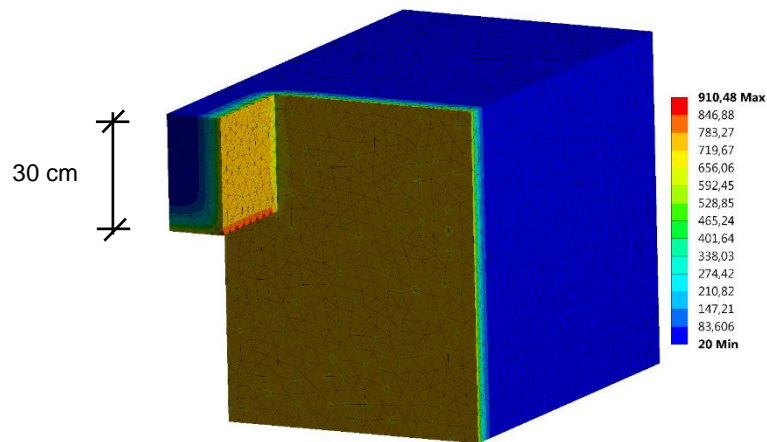

Figure 7: temperature profiles after 30 minutes fire duratuion

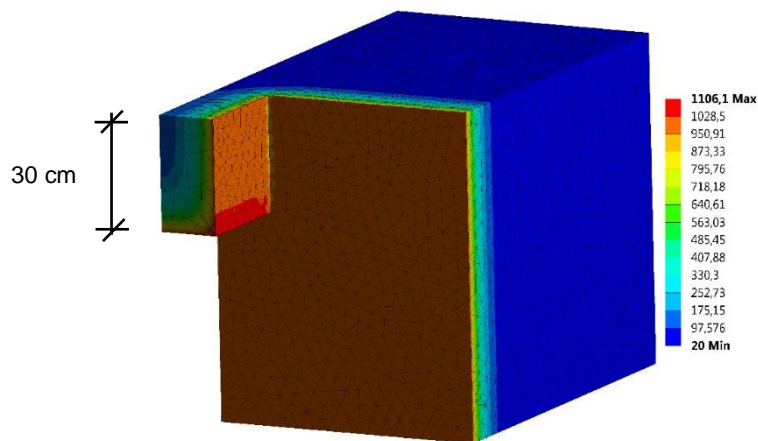

Figure 8: temperature profiles after 120 minutes fire duratuion

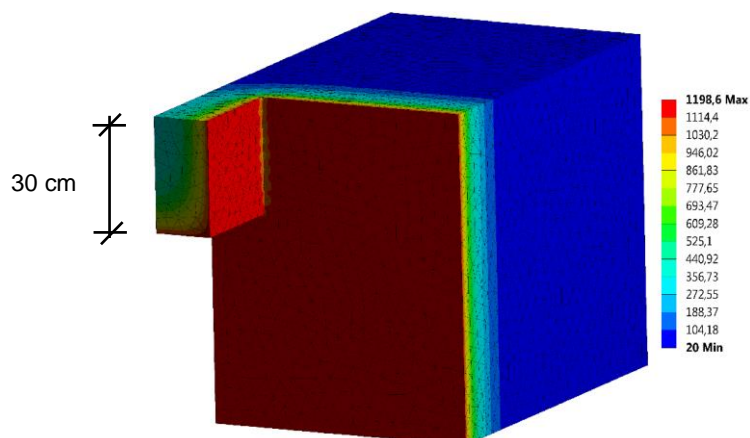

Figure 9: temperature profiles after 240 minutes fire duratuion

6. Simulation results

6.1. Maximum applicable bond stress for slab-slab connections

Table 1 presents characteristic bond stresses for slab-slab connections using C20/25 concrete with concrete covers between 50 and 230 mm and rebars with a yield strength $f_y = 500 \text{ N/mm}^2$ (see figure 6).

This model is exposed to a fire defined by the standard temperature curve as reference DIN ISO 834-1 [6] (At 30, 60, 90, 120, 180, 240 min).

- The following table supplies data for the design of the injection anchoring system in case of fire.
- Post-installed rebars shall be designed in ambient temperature conditions before being designed in fire conditions.
- The mechanical design at ambient temperature has not been considered in this study. It shall be done additionally.
- The reduction of the steel load capacity due to elevated temperature in the steel was not taken into account in the tables.
- Intermediate values between those given in the following fire design tables may be interpolated.
- For higher concrete strength classes, the values of concrete strength class C20/25 may be used.

Report on fire evaluation of post installed rebar connections with fischer FIS V Plus / FIS V Plus Low Speed injection system

Table 1: Slab-slab connection

Concrete cover c_{nom} [mm]	Characteristic bond resistance in case of fire $f_{bk,fire}$ [N/mm ²]							
	R30	R60	R90	R120	R180	R240		
50	1,9	0,4	0,0	0,0	0,0	0,0		
60	2,8	0,8	0,3					
70	3,5	1,3	0,5	0,3				
80		2,0	0,9	0,5				
90		2,6	1,4	0,7	0,3			
100		3,2	1,9	1,1	0,4	0,2		
110		3,5	3,5	2,4	1,5	0,6	0,3	
120				2,8	1,9	0,9	0,5	
130				3,3	2,4	1,2	0,6	
140				3,5	3,5	3,5	2,8	1,5
150		3,2	1,9				1,1	
160		2,3	1,4					
170	2,6	1,7						
180	3,0	2,0						
190	3,3	2,4						
200	3,5	3,5	3,5				3,5	2,7
210								2,9
220				3,2				
230				3,5				

6.2. Maximum applicable loads for beam-wall connections

Characteristic load resistances are calculated for beam-wall connections using C20/25 concrete and concrete cover equal or larger than 10 mm. The rebars used have a yield strength $f_y = 500 \text{ N/mm}^2$ and a characteristic maximum force of $N_{RK} = A_s \times f_y$.

This model is exposed to a fire defined by the standard temperature curve as reference DIN ISO 834-1 [6]. (At 30, 60, 90, 120, 180, 240 min).

- The following table supplies data for the design of the injection anchoring system in case of fire.
- Post-installed rebars shall be designed in ambient temperature conditions before being designed in fire conditions.
- The mechanical design at ambient temperature has not been considered in this study. It shall be done additionally.
- The reduction of the steel load capacity due to elevated temperature in the steel was not taken into account in the tables.
- Intermediate values between those given in the following fire design tables may be interpolated.
- For higher concrete strength classes, the values of concrete strength class C20/25 may be used.

Report on fire evaluation of post installed rebar connections with fischer FIS V Plus / FIS V Plus Low Speed injection system

6.2.1. Maximum applicable loads for a beam-wall connection with a concrete cover of 10mm

Table 2: beam-wall connection for $c_{nom,min} = 10\text{mm}$ and $\varnothing 8\text{mm}$

Concrete Cover = 10mm		Characteristic load resistance in case of fire $N_{Rk,fire}$ [kN]						
\varnothing [mm]	l_v [mm]	R30	R60	R90	R120	R180	R240	
8	100	4,5	2,1	1,1	0,4	0,2	0,1	
	110	5,4	2,6	1,3	0,4	0,3	0,1	
	140	8,0	5,5	3,7	2,3	1,2	0,6	
	170	10,6	8,1	6,3	4,5	2,6	1,5	
	200	13,2	10,7	8,9	7,3	5,1	3,3	
	230	15,8	13,3	11,5	9,9	7,7	5,5	
	260	18,4	15,9	14,1	12,5	10,3	8,2	
	290	21,0	18,5	16,7	15,1	12,9	10,8	
	320	23,6	21,1	19,3	17,7	15,5	13,5	
	340	25,1	25,1	22,8	21,1	19,4	17,2	15,2
	370			23,7	22,0	19,8	17,8	
	390			25,1	23,8	21,6	19,5	
	410				25,1	23,3	21,3	
	440					23,9		
	460			25,1	25,1			

Report on fire evaluation of post installed rebar connections with fischer FIS V Plus / FIS V Plus Low Speed injection system

Table 3: beam-wall connection for $C_{nom,min} = 10\text{mm}$ and $\varnothing 10\text{mm}$

Concrete Cover = 10mm		Characteristic load resistance in case of fire $N_{Rk,fire}$ [kN]						
\varnothing [mm]	l_v [mm]	R30	R60	R90	R120	R180	R240	
10	100	5,5	2,5	1,2	0,4	0,3	0,1	
	110	6,6	3,0	1,5	0,5	0,3	0,1	
	140	9,8	6,6	4,3	2,6	1,4	0,7	
	170	13,1	9,8	7,6	5,2	3,0	1,7	
	200	16,3	13,1	10,8	8,7	6,0	3,9	
	230	19,6	16,3	14,1	12,0	9,3	6,5	
	260	22,8	19,6	17,3	15,2	12,5	9,9	
	290	26,1	22,8	20,6	18,5	15,8	13,2	
	320	29,3	26,1	23,8	21,7	19,0	16,4	
	350	32,6	29,3	27,1	25,0	22,3	19,7	
	380	35,8	32,6	30,3	28,3	25,5	22,9	
	410	39,1	35,8	33,6	31,5	28,8	26,2	
	420	39,3	39,3	36,9	34,7	32,6	29,9	27,3
	450			37,9	35,8	33,1	30,5	
	470			39,3	38,0	35,3	32,7	
	490				39,3	37,5	34,8	
510	39,3			37,0				
540	39,3							

Report on fire evaluation of post installed rebar connections with fischer FIS V Plus / FIS V Plus Low Speed injection system

6.2.2. Maximum applicable loads for a beam-wall connection with a concrete cover of 20mm

Table 4: beam-wall connection for $c_{nom,min} = 20mm$ and $\varnothing 8mm$

Concrete Cover = 20mm		Characteristic load resistance in case of fire $N_{Rk,fire}$ [kN]					
\varnothing [mm]	l_v [mm]	R30	R60	R90	R120	R180	R240
8	100	5,3	2,6	1,3	0,6	0,3	0,1
	110	6,1	3,1	1,5	0,6	0,3	0,1
	140	8,7	6,0	4,1	2,6	1,3	0,7
	170	11,3	8,6	6,7	4,9	2,8	1,6
	200	13,9	11,2	9,3	7,6	5,4	3,5
	230	16,5	13,8	11,9	10,2	8,0	5,7
	260	19,1	16,4	14,5	12,8	10,6	8,5
	290	21,7	19,0	17,1	15,4	13,2	11,1
	320	24,3	21,6	19,7	18,0	15,8	13,7
	330	25,1	22,4	20,5	18,9	16,6	14,5
	360		25,0	23,1	21,5	19,2	17,1
	370		24,0	22,4	20,1	18,0	
	390		24,1	21,8	19,7		
	410		25,1	23,6	21,5		
	430		25,1	23,2			
460	25,1						

Report on fire evaluation of post installed rebar connections with fischer FIS V Plus / FIS V Plus Low Speed injection system

Table 5: beam-wall connection for $C_{nom,min} = 20\text{mm}$ and $\varnothing 10\text{mm}$

Concrete Cover = 20mm		Characteristic load resistance in case of fire $N_{Rk,fire}$ [kN]						
\varnothing [mm]	lv [mm]	R30	R60	R90	R120	R180	R240	
10	100	6,5	3,0	1,5	0,7	0,3	0,1	
	110	7,6	3,6	1,8	0,7	0,4	0,1	
	140	10,8	7,2	4,8	3,0	1,6	0,8	
	170	14,1	10,4	8,1	5,8	3,3	1,9	
	200	17,3	13,7	11,3	9,3	6,4	4,1	
	230	20,6	16,9	14,6	12,5	9,6	6,8	
	260	23,8	20,2	17,8	15,8	12,9	10,2	
	290	27,1	23,4	21,1	19,0	16,1	13,5	
	320	30,3	26,7	24,3	22,3	19,4	16,7	
	350	33,6	29,9	27,6	25,6	22,6	20,0	
	380	36,8	33,2	30,8	28,8	25,9	23,2	
	410	39,3	39,3	36,4	34,1	32,1	29,1	26,5
	440			37,3	35,3	32,4	29,7	
	460			39,3	37,5	34,6	31,9	
	490				39,3	37,8	35,2	
520	39,3					38,4		
530	39,3			39,3				

Report on fire evaluation of post installed rebar connections with fischer FIS V Plus / FIS V Plus Low Speed injection system

Table 6: beam-wall connection for $C_{nom,min} = 20\text{mm}$ and $\varnothing 12\text{mm}$

Concrete Cover = 20mm		Characteristic maximum force in the rebar [kN]						
\varnothing [mm]	lv [mm]	R30	R60	R90	R120	R180	R240	
12	110	9,0	4,1	2,0	0,8	0,4	0,1	
	140	12,9	8,4	5,5	3,4	1,8	0,9	
	170	16,8	12,3	9,3	6,5	3,7	2,1	
	200	20,7	16,2	13,3	10,7	7,3	4,7	
	230	24,6	20,1	17,2	14,6	11,2	7,8	
	260	28,5	24,0	21,1	18,5	15,1	11,9	
	290	32,4	27,9	25,0	22,4	19,0	15,8	
	320	36,3	31,8	28,9	26,3	22,9	19,7	
	350	40,2	35,7	32,8	30,2	26,8	23,6	
	380	44,1	39,6	36,7	34,1	30,7	27,5	
	410	48,0	43,5	40,6	38,0	34,6	31,4	
	440	51,9	47,4	44,5	41,9	38,5	35,3	
	470	55,8	51,3	48,4	45,8	42,4	39,2	
	480	56,5	56,5	52,6	49,7	47,1	43,7	40,5
	510			56,5	53,6	51,1	47,6	44,4
	540				56,5	55,0	51,5	48,3
	560			56,5		54,1	50,9	
580	56,5					53,5		
610				56,5				

Report on fire evaluation of post installed rebar connections with fischer FIS V Plus / FIS V Plus Low Speed injection system

Table 7: beam-wall connection for $C_{nom,min} = 20\text{mm}$ and $\varnothing 14\text{mm}$

Concrete Cover = 20mm		Characteristic load resistance in case of fire $N_{Rk,fire}$ [kN]						
\varnothing [mm]	lv [mm]	R30	R60	R90	R120	R180	R240	
14	140	15,1	9,6	6,1	3,8	1,9	1,0	
	170	19,6	14,1	10,4	7,2	4,0	2,3	
	200	24,2	18,7	15,1	12,1	8,0	5,1	
	230	28,7	23,2	19,6	16,7	12,4	8,5	
	260	33,3	27,8	24,2	21,2	17,0	13,3	
	290	37,8	32,3	28,7	25,8	21,6	17,9	
	320	42,4	36,9	33,3	30,3	26,1	22,4	
	350	47,0	41,4	37,8	34,9	30,7	27,0	
	380	51,5	46,0	42,4	39,4	35,2	31,6	
	410	56,1	50,5	46,9	44,0	39,8	36,1	
	440	60,6	55,1	51,5	48,5	44,4	40,7	
	470	65,2	59,6	56,0	53,1	48,9	45,2	
	500	69,7	64,2	60,6	57,6	53,5	49,8	
	530	74,3	68,7	65,1	62,2	58,0	54,3	
	550	77,0	77,0	71,8	68,2	65,2	61,0	57,3
	580			76,3	72,7	69,8	65,6	61,9
	590			77,0	74,2	71,3	67,1	63,4
	610				77,0	74,3	70,1	66,5
	630					73,2	69,5	
660	77,0			77,0	77,0	77,0	74,0	
680							77,0	

Report on fire evaluation of post installed rebar connections with fischer FIS V Plus / FIS V Plus Low Speed injection system

Table 8: beam-wall connection for $C_{nom,min} = 20\text{mm}$ and $\varnothing 16\text{mm}$

Concrete Cover = 20mm		Characteristic maximum force in the rebar [kN]					
\varnothing [mm]	lv [mm]	R30	R60	R90	R120	R180	R240
16	160	20,7	14,1	9,8	6,7	3,7	2,1
	190	25,9	19,3	15,1	11,4	6,8	4,1
	220	31,1	24,5	20,3	16,9	12,0	8,1
	250	36,3	29,7	25,5	22,1	17,2	12,6
	280	41,5	34,9	30,7	27,3	22,4	18,1
	310	46,7	40,1	35,9	32,5	27,6	23,3
	340	51,9	45,3	41,1	37,7	32,8	28,5
	370	57,1	50,5	46,3	42,9	38,0	33,7
	400	62,3	55,7	51,5	48,1	43,2	38,9
	430	67,6	60,9	56,7	53,3	48,4	44,1
	460	72,8	66,2	61,9	58,5	53,6	49,3
	490	78,0	71,4	67,1	63,7	58,8	54,5
	520	83,2	76,6	72,3	68,9	64,0	59,7
	550	88,4	81,8	77,5	74,1	69,2	64,9
	580	93,6	87,0	82,7	79,3	74,4	70,1
	610	98,8	92,2	87,9	84,5	79,6	75,3
	620	100,5	93,9	89,6	86,2	81,3	77,1
	650	100,5	99,1	94,8	91,4	86,5	82,3
	660	100,5	100,5	96,6	93,2	88,3	84,0
	690			98,4	93,5	89,2	
710	100,5			96,9	92,7		
740				97,9			
760	100,5			100,5			

Report on fire evaluation of post installed rebar connections with fischer FIS V Plus / FIS V Plus Low Speed injection system

Table 9: beam-wall connection for $C_{nom,min} = 20\text{mm}$ and $\varnothing 20\text{mm}$

Concrete Cover = 20mm		Characteristic maximum force in the rebar [kN]					
\varnothing [mm]	lv [mm]	R30	R60	R90	R120	R180	R240
20	200	34,7	25,5	20,0	15,6	9,7	6,1
	230	41,2	32,0	26,5	22,1	15,4	10,3
	260	47,7	38,5	33,0	28,6	22,3	16,7
	290	54,2	45,0	39,6	35,1	28,8	23,2
	320	60,7	51,5	46,1	41,6	35,3	29,7
	350	67,2	58,0	52,6	48,1	41,8	36,2
	380	73,7	64,5	59,1	54,6	48,3	42,7
	410	80,2	71,0	65,6	61,1	54,8	49,2
	440	86,7	77,5	72,1	67,6	61,3	55,8
	470	93,2	84,0	78,6	74,1	67,8	62,3
	500	99,7	90,5	85,1	80,6	74,3	68,8
	530	106,2	97,0	91,6	87,1	80,8	75,3
	560	112,7	103,5	98,1	93,6	87,3	81,8
	590	119,2	110,0	104,6	100,1	93,8	88,3
	620	125,7	116,5	111,1	106,6	100,3	94,8
	650	132,2	123,0	117,6	113,1	106,8	101,3
	670	136,6	127,4	121,9	117,5	111,1	105,6
	700	143,1	133,9	128,4	124,0	117,6	112,1
	730	149,6	140,4	134,9	130,5	124,1	118,6
	760	156,1	146,9	141,4	137,0	130,6	125,1
770			149,1	143,6	139,1	132,8	127,3
800			155,6	150,1	145,6	139,3	133,8
810				152,3	147,8	141,5	136,0
840		157,1			154,3	148,0	142,5
860			157,1			152,3	146,8
890				157,1	157,1		153,3
910						157,1	157,1

Report on fire evaluation of post installed rebar connections with fischer FIS V Plus / FIS V Plus Low Speed injection system

6.2.3. Maximum applicable loads for a beam-wall connection with a concrete cover of 30mm

Table 10: beam-wall connection for $C_{nom,min} = 30\text{mm}$ and $\varnothing 8\text{mm}$

Concrete Cover = 30mm		Characteristic maximum force in the rebar [kN]						
\varnothing [mm]	lv [mm]	R30	R60	R90	R120	R180	R240	
8	100	6,2	3,2	1,6	0,7	0,3	0,1	
	110	7,1	3,8	2,0	0,8	0,4	0,1	
	140	9,7	6,6	4,6	2,9	1,5	0,8	
	170	12,3	9,2	7,2	5,3	3,0	1,7	
	200	14,9	11,8	9,8	8,0	5,6	3,7	
	230	17,5	14,5	12,4	10,6	8,2	6,0	
	260	20,1	17,1	15,0	13,2	10,8	8,7	
	290	22,7	19,7	17,6	15,8	13,4	11,3	
	320	25,1	25,1	22,3	20,2	18,4	16,0	13,9
	350			24,9	22,8	21,0	18,6	16,5
	360			25,1	23,7	21,9	19,5	17,4
	380				25,1	23,6	21,2	19,1
	400			25,1		23,0	20,9	
	430					25,1	23,5	
	450			25,1				

Report on fire evaluation of post installed rebar connections with fischer FIS V Plus / FIS V Plus Low Speed injection system

Table 11: beam-wall connection for $c_{nom,min} = 30\text{mm}$ and $\varnothing 10\text{mm}$

Concrete Cover = 30mm		Characteristic maximum force in the rebar [kN]						
\varnothing [mm]	lv [mm]	R30	R60	R90	R120	R180	R240	
10	100	7,8	3,9	2,0	0,8	0,4	0,1	
	110	8,9	4,6	2,3	0,9	0,5	0,1	
	140	12,1	8,1	5,5	3,4	1,8	0,9	
	170	15,4	11,4	8,8	6,3	3,6	2,0	
	200	18,6	14,7	12,0	9,7	6,8	4,4	
	230	21,9	17,9	15,3	13,0	10,0	7,1	
	260	25,1	21,2	18,5	16,2	13,3	10,6	
	290	28,4	24,4	21,8	19,5	16,5	13,8	
	320	31,7	27,7	25,0	22,7	19,8	17,1	
	350	34,9	30,9	28,3	26,0	23,0	20,3	
	380	38,2	34,2	31,5	29,2	26,3	23,6	
	400	39,3	39,3	36,3	33,7	31,4	28,4	25,7
	430			37,0	34,7	31,7	29,0	
	460			37,9	34,9	32,2		
	480			39,3	37,1	34,4		
	500				39,3	36,6		
530	39,3							

Report on fire evaluation of post installed rebar connections with fischer FIS V Plus / FIS V Plus Low Speed injection system

Table 12: beam-wall connection for $C_{nom,min} = 30\text{mm}$ and $\varnothing 12\text{mm}$

Concrete Cover = 30mm		Characteristic maximum force in the rebar [kN]					
\varnothing [mm]	lv [mm]	R30	R60	R90	R120	R180	R240
12	110	10,7	5,3	2,7	1,0	0,5	0,1
	140	14,6	9,6	6,4	3,9	2,0	1,0
	170	18,5	13,5	10,3	7,2	4,1	2,3
	200	22,4	17,4	14,2	11,4	7,8	5,0
	230	26,3	21,3	18,1	15,3	11,7	8,1
	260	30,2	25,2	22,0	19,2	15,6	12,3
	290	34,1	29,1	25,9	23,1	19,5	16,2
	320	38,0	33,0	29,8	27,0	23,4	20,1
	350	41,9	36,9	33,7	30,9	27,3	24,0
	380	45,8	40,8	37,6	34,8	31,2	27,9
	410	49,7	44,7	41,5	38,7	35,1	31,8
	440	53,6	48,6	45,4	42,6	39,0	35,7
	470	56,5	52,5	49,3	46,5	42,9	39,6
	500		56,4	53,2	50,4	46,8	43,5
	510		56,5	54,5	51,7	48,1	44,8
	530			54,3	50,7	47,4	
	550		56,5	56,5	56,5	53,3	50,0
	580					56,5	53,9
600	56,5						

Report on fire evaluation of post installed rebar connections with fischer FIS V Plus / FIS V Plus Low Speed injection system

Table 13: beam-wall connection for $C_{nom,min} = 30\text{mm}$ and $\varnothing 14\text{mm}$

Concrete Cover = 30mm		Characteristic maximum force in the rebar [kN]							
\varnothing [mm]	lv [mm]	R30	R60	R90	R120	R180	R240		
14	140	17,0	11,0	7,2	4,3	2,2	1,1		
	170	21,6	15,5	11,8	8,0	4,5	2,5		
	200	26,1	20,1	16,3	12,9	8,6	5,5		
	230	30,7	24,6	20,9	17,5	13,1	9,0		
	260	35,2	29,2	25,4	22,0	17,7	13,8		
	290	39,8	33,8	30,0	26,6	22,3	18,4		
	320	44,3	38,3	34,5	31,1	26,8	22,9		
	350	48,9	42,9	39,1	35,7	31,4	27,5		
	380	53,4	47,4	43,6	40,2	35,9	32,0		
	410	58,0	52,0	48,2	44,8	40,5	36,6		
	440	62,5	56,5	52,7	49,3	45,0	41,1		
	470	67,1	61,1	57,3	53,9	49,6	45,7		
	500	71,6	65,6	61,8	58,4	54,1	50,2		
	530	76,2	70,2	66,4	63,0	58,7	54,8		
	540	77,0	77,0	71,7	67,9	64,5	60,2	56,3	
	570			76,2	72,4	69,1	64,7	60,9	
	580			77,0	77,0	74,0	70,6	66,3	62,4
	600					77,0	77,0	73,6	69,3
	630			77,0	77,0			77,0	73,8
	660					77,0	77,0		77,0
680	77,0			77,0	77,0			77,0	

Report on fire evaluation of post installed rebar connections with fischer FIS V Plus / FIS V Plus Low Speed injection system

Table 14: beam-wall connection for $c_{nom,min} = 30\text{mm}$ and $\varnothing 16\text{mm}$

Concrete Cover = 30mm		Characteristic maximum force in the rebar [kN]						
\varnothing [mm]	lv [mm]	R30	R60	R90	R120	R180	R240	
16	160	23,0	15,8	11,2	7,5	4,1	2,3	
	190	28,2	21,0	16,4	12,4	7,4	4,5	
	220	33,4	26,2	21,6	17,8	12,7	8,7	
	250	38,6	31,4	26,8	23,0	17,9	13,3	
	280	43,8	36,6	32,0	28,2	23,1	18,8	
	310	49,0	41,8	37,2	33,4	28,3	24,0	
	340	54,2	47,0	42,4	38,6	33,5	29,2	
	370	59,4	52,2	47,6	43,8	38,7	34,4	
	400	64,6	57,4	52,8	49,0	43,9	39,6	
	430	69,8	62,6	58,0	54,2	49,2	44,8	
	460	75,0	67,8	63,2	59,4	54,4	50,0	
	490	80,2	73,0	68,4	64,6	59,6	55,2	
	520	85,4	78,2	73,6	69,8	64,8	60,4	
	550	90,6	83,4	78,8	75,0	70,0	65,6	
	580	95,8	88,6	84,0	80,2	75,2	70,8	
	610	100,5	100,5	93,8	89,2	85,4	80,4	76,0
	640			99,0	94,4	90,6	85,6	81,2
	650			100,5	96,2	92,3	87,3	83,0
	680				100,5	97,5	92,5	88,2
	700			100,5		96,0	91,6	
730	100,5				96,8			
760				100,5				

Report on fire evaluation of post installed rebar connections with fischer FIS V Plus / FIS V Plus Low Speed injection system

Table 15: beam-wall connection for $c_{nom,min} = 30\text{mm}$ and $\varnothing 20\text{mm}$

Concrete Cover = 30mm		Characteristic maximum force in the rebar [kN]					
\varnothing [mm]	lv [mm]	R30	R60	R90	R120	R180	R240
20	200	37,7	28,2	22,1	17,0	10,8	6,8
	230	44,2	34,7	28,6	23,5	16,7	11,2
	260	50,7	41,2	35,1	30,0	23,5	17,7
	290	57,2	47,7	41,6	36,5	30,0	24,2
	320	63,7	54,3	48,1	43,0	36,5	30,7
	350	70,2	60,8	54,6	49,5	43,0	37,2
	380	76,7	67,3	61,1	56,0	49,5	43,7
	410	83,2	73,8	67,6	62,5	56,0	50,2
	440	89,7	80,3	74,1	69,0	62,5	56,7
	470	96,2	86,8	80,6	75,5	69,0	63,2
	500	102,7	93,3	87,1	82,1	75,5	69,7
	530	109,2	99,8	93,6	88,6	82,0	76,2
	560	115,7	106,3	100,1	95,1	88,5	82,8
	590	122,2	112,8	106,6	101,6	95,0	89,3
	620	128,8	119,3	113,1	108,1	101,6	95,8
	650	135,3	125,8	119,6	114,6	108,1	102,3
	680	141,8	132,3	126,1	121,1	114,6	108,8
	710	148,3	138,8	132,6	127,6	121,1	115,3
	740	154,8	145,3	139,1	134,1	127,6	121,8
	760	157,1	157,1	149,6	143,5	138,4	131,9
790	156,1			150,0	144,9	138,4	132,6
800	157,1			152,1	147,1	140,6	134,8
830				153,6	147,1	141,3	
850	157,1			157,1	157,1	151,4	145,6
880						157,1	152,1
910							157,1

Report on fire evaluation of post installed rebar connections with fischer FIS V Plus / FIS V Plus Low Speed injection system

Table 16: beam-wall connection for $c_{nom,min} = 30\text{mm}$ and $\varnothing 25\text{mm}$

Concrete Cover = 30mm		Characteristic load resistance in case of fire $N_{Rk,fire}$ [kN]					
\varnothing [mm]	lv [mm]	R30	R60	R90	R120	R180	R240
25	250	61,3	48,7	40,2	33,4	24,5	17,0
	280	69,4	56,8	48,3	41,5	32,8	25,5
	310	77,5	64,9	56,5	49,7	40,9	33,6
	340	85,7	73,0	64,6	57,8	49,0	41,8
	370	93,8	81,2	72,7	65,9	57,2	49,9
	400	101,9	89,3	80,8	74,1	65,3	58,0
	430	110,1	97,4	89,0	82,2	73,4	66,1
	460	118,2	105,6	97,1	90,3	81,6	74,3
	490	126,3	113,7	105,2	98,4	89,7	82,4
	520	134,4	121,8	113,4	106,6	97,8	90,5
	550	142,6	129,9	121,5	114,7	105,9	98,7
	580	150,7	138,1	129,6	122,8	114,1	106,8
	610	158,8	146,2	137,7	131,0	122,2	114,9
	640	167,0	154,3	145,9	139,1	130,3	123,0
	670	175,1	162,5	154,0	147,2	138,5	131,2
	700	183,2	170,6	162,1	155,3	146,6	139,3
	730	191,3	178,7	170,3	163,5	154,7	147,4
	760	199,5	186,9	178,4	171,6	162,8	155,6
	790	207,6	195,0	186,5	179,7	171,0	163,7
	820	215,7	203,1	194,6	187,9	179,1	171,8
	850	223,9	211,2	202,8	196,0	187,2	179,9
	880	232,0	219,4	210,9	204,1	195,4	188,1
	910	240,1	227,5	219,0	212,3	203,5	196,2
	930	245,4	232,9	224,5	217,7	208,9	201,6
	960		241,0	232,6	225,8	217,0	209,8
980	245,4		238,0	231,2	222,5	215,2	
1010			245,4	239,3	230,6	223,3	
1040	245,4			238,7	231,4		
1070			245,4	239,6			
1100	245,4						

Report on fire evaluation of post installed rebar connections with fischer FIS V Plus / FIS V Plus Low Speed injection system

Table 17: beam-wall connection for $C_{nom,min} = 30\text{mm}$ and $\varnothing 28\text{mm}$

Concrete Cover = 30mm		Characteristic load resistance in case of fire $N_{Rk,fire}$ [kN]						
\varnothing [mm]	l_v [mm]	R30	R60	R90	R120	R180	R240	
28	280	78,3	63,6	53,6	45,8	35,7	27,1	
	310	87,4	72,7	62,8	54,9	44,8	36,2	
	340	96,5	81,8	71,9	64,0	53,9	45,3	
	370	105,6	90,9	81,0	73,1	63,0	54,4	
	400	114,7	100,0	90,1	82,2	72,1	63,5	
	430	123,8	109,1	99,2	91,3	81,2	72,6	
	460	132,9	118,2	108,3	100,4	90,3	81,7	
	490	142,0	127,3	117,4	109,5	99,4	90,9	
	520	151,1	136,4	126,5	118,6	108,5	100,0	
	550	160,2	145,5	135,6	127,7	117,6	109,1	
	580	169,3	154,6	144,7	136,8	126,7	118,2	
	610	178,4	163,7	153,8	145,9	135,8	127,3	
	640	187,5	172,8	162,9	155,0	144,9	136,4	
	670	196,6	181,9	172,0	164,1	154,0	145,5	
	700	205,7	191,0	181,1	173,2	163,1	154,6	
	730	214,8	200,1	190,2	182,3	172,2	163,7	
	760	223,9	209,2	199,3	191,4	181,3	172,8	
	790	233,0	218,3	208,4	200,5	190,4	181,9	
	820	242,1	227,4	217,5	209,6	199,5	191,0	
	850	251,2	236,5	226,6	218,7	208,6	200,1	
	880	260,3	245,6	235,7	227,9	217,8	209,2	
	910	269,4	254,7	244,8	237,0	226,9	218,3	
	940	278,6	263,8	253,9	246,1	236,0	227,4	
	970	287,7	273,0	263,0	255,2	245,1	236,5	
	1000	296,8	282,1	272,2	264,3	254,2	245,6	
	1030	305,9	291,2	281,3	273,4	263,3	254,7	
	1040	307,9	307,9	294,2	284,3	276,4	266,3	257,8
	1070			303,3	293,4	285,5	275,4	266,9
1090	307,9			299,5	291,6	281,5	272,9	
1120				307,9	300,7	290,6	282,0	
1150	307,9				299,7	291,1		
1180				307,9	300,3			
1210	307,9							

Report on fire evaluation of post installed rebar connections with fischer FIS V Plus / FIS V Plus Low Speed injection system

6.2.4. Maximum applicable loads for a beam-wall connection with a concrete cover of 40mm

Table 18: beam-wall connection for $c_{nom,min} = 40\text{mm}$ and $\varnothing 8\text{mm}$

Concrete Cover = 40mm		Characteristic load resistance in case of fire $N_{Rk,fire}$ [kN]						
\varnothing [mm]	l_v [mm]	R30	R60	R90	R120	R180	R240	
8	100	7,1	3,9	2,0	0,9	0,4	0,2	
	110	8,0	4,6	2,4	1,0	0,5	0,2	
	140	10,6	7,3	5,1	3,3	1,7	1,0	
	170	13,2	9,9	7,7	5,8	3,3	2,0	
	200	15,8	12,5	10,3	8,4	6,0	4,0	
	230	18,4	15,1	12,9	11,0	8,6	6,4	
	260	21,0	17,7	15,5	13,6	11,2	9,1	
	290	23,6	20,3	18,1	16,2	13,8	11,7	
	310	25,1	25,1	22,1	19,9	18,0	15,5	13,4
	340			24,7	22,5	20,6	18,1	16,1
	350			25,1	23,4	21,5	19,0	16,9
	370				25,1	23,2	20,7	18,7
	400			25,1		25,1	25,1	23,3
	420				25,1			23,0
	450				25,1			25,1

Report on fire evaluation of post installed rebar connections with fischer FIS V Plus / FIS V Plus Low Speed injection system

Table 19: beam-wall connection for $c_{nom,min} = 40\text{mm}$ and $\varnothing 10\text{mm}$

Concrete Cover = 40mm		Characteristic load resistance in case of fire $N_{Rk,fire}$ [kN]							
\varnothing [mm]	l_v [mm]	R30	R60	R90	R120	R180	R240		
10	100	9,0	4,8	2,4	1,1	0,5	0,2		
	110	10,0	5,7	2,9	1,2	0,6	0,3		
	140	13,3	9,2	6,3	4,0	2,0	1,1		
	170	16,5	12,4	9,5	7,0	4,0	2,4		
	200	19,8	15,7	12,8	10,3	7,2	4,8		
	230	23,1	18,9	16,0	13,6	10,5	7,7		
	260	26,3	22,2	19,3	16,8	13,7	11,1		
	290	29,6	25,4	22,5	20,1	17,0	14,3		
	320	32,8	28,7	25,8	23,3	20,2	17,6		
	350	36,1	31,9	29,0	26,6	23,5	20,8		
	380	39,3	39,3	35,2	32,3	29,9	26,7	24,1	
	410			38,4	35,5	33,1	30,0	27,3	
	420			39,3	39,3	36,6	34,2	31,0	28,4
	450					37,4	34,3	31,7	
	470			39,3	39,3	39,3	36,5	33,8	
	500						39,3	37,1	
520	39,3								

Report on fire evaluation of post installed rebar connections with fischer FIS V Plus / FIS V Plus Low Speed injection system

Table 20: beam-wall connection for $c_{nom,min} = 40\text{mm}$ and $\varnothing 12\text{mm}$

Concrete Cover = 40mm		Characteristic load resistance in case of fire $N_{Rk,fire}$ [kN]						
\varnothing [mm]	l_v [mm]	R30	R60	R90	R120	R180	R240	
12	100	10,9	5,8	2,9	1,3	0,5	0,1	
	110	12,2	6,7	3,4	1,5	0,7	0,1	
	140	16,1	11,0	7,3	4,6	2,3	1,2	
	170	20,0	14,9	11,2	8,1	4,5	2,6	
	200	23,9	18,8	15,1	12,2	8,3	5,4	
	230	27,8	22,7	19,0	16,1	12,2	8,6	
	260	31,7	26,6	22,9	20,0	16,1	12,8	
	290	35,6	30,5	26,8	23,9	20,0	16,7	
	320	39,5	34,4	30,7	27,8	23,9	20,6	
	350	43,4	38,3	34,6	31,7	27,8	24,5	
	380	47,3	42,2	38,5	35,6	31,7	28,4	
	410	51,2	46,1	42,4	39,5	35,6	32,3	
	440	55,1		46,3	43,4	39,5	36,2	
	460		56,5	52,6	48,9	46,0	42,1	38,8
	490				52,8	49,9	46,0	42,7
	520					53,8	49,9	46,6
	550			56,5			53,9	50,5
570				56,5			53,1	
600					56,5	56,5	56,5	

Report on fire evaluation of post installed rebar connections with fischer FIS V Plus / FIS V Plus Low Speed injection system

Table 21: beam-wall connection for $c_{nom,min} = 40\text{mm}$ and $\varnothing 14\text{mm}$

Concrete Cover = 40mm		Characteristic load resistance in case of fire $N_{Rk,fire}$ [kN]						
\varnothing [mm]	lv [mm]	R30	R60	R90	R120	R180	R240	
14	140	18,9	12,7	8,4	5,2	2,6	1,3	
	170	23,4	17,3	13,0	9,1	5,1	2,9	
	200	28,0	21,8	17,5	14,0	9,4	6,0	
	230	32,5	26,4	22,1	18,5	13,9	9,6	
	260	37,1	30,9	26,7	23,1	18,5	14,4	
	290	41,6	35,5	31,2	27,6	23,0	19,0	
	320	46,2	40,0	35,8	32,2	27,6	23,5	
	350	50,7	44,6	40,3	36,8	32,1	28,1	
	380	55,3	49,1	44,9	41,3	36,7	32,7	
	410	59,8	53,7	49,4	45,9	41,2	37,2	
	440	64,4	58,2	54,0	50,4	45,8	41,8	
	470	68,9	62,8	58,5	55,0	50,3	46,3	
	500	73,5	67,3	63,1	59,5	54,9	50,9	
	530	77,0	77,0	71,9	67,6	64,1	59,4	55,4
	560			76,4	72,2	68,6	64,0	60,0
	570			77,0	73,7	70,1	65,5	61,5
	600				74,7	70,1	66,0	
	620			77,0	77,0	77,0	73,1	69,1
650	73,6							
680	77,0							

Report on fire evaluation of post installed rebar connections with fischer FIS V Plus / FIS V Plus Low Speed injection system

Table 22: beam-wall connection for $c_{nom,min} = 40\text{mm}$ and $\varnothing 16\text{mm}$

Concrete Cover = 40mm		Characteristic load resistance in case of fire $N_{Rk,fire}$ [kN]						
\varnothing [mm]	l_v [mm]	R30	R60	R90	R120	R180	R240	
16	160	25,2	17,9	12,9	8,7	4,7	2,6	
	190	30,4	23,1	18,1	13,9	8,3	5,0	
	220	35,6	28,3	23,3	19,1	13,7	9,3	
	250	40,8	33,5	28,5	24,3	18,9	14,1	
	280	46,0	38,7	33,7	29,5	24,1	19,5	
	310	51,2	43,9	38,9	34,7	29,3	24,7	
	340	56,4	49,1	44,1	39,9	34,5	29,9	
	370	61,6	54,3	49,3	45,1	39,7	35,1	
	400	66,8	59,5	54,5	50,3	44,9	40,3	
	430	72,0	64,7	59,7	55,5	50,1	45,5	
	460	77,2	69,9	64,9	60,7	55,3	50,7	
	490	82,4	75,1	70,1	65,9	60,5	55,9	
	520	87,6	80,3	75,3	71,1	65,7	61,1	
	550	92,8	85,5	80,5	76,3	70,9	66,3	
	580	98,0	90,7	85,7	81,5	76,1	71,5	
	600	100,5	100,5	94,2	89,2	85,0	79,6	75,0
	630			99,4	94,4	90,2	84,8	80,2
	640			100,5	96,1	91,9	86,5	81,9
	670				100,5	97,1	91,7	87,1
	690			100,5		95,2	90,6	
720	100,4				95,8			
730	100,5			97,5				
750	100,5			100,5				

Report on fire evaluation of post installed rebar connections with fischer FIS V Plus / FIS V Plus Low Speed injection system

Table 23: beam-wall connection for $C_{nom,min} = 40\text{mm}$ and $\varnothing 20\text{mm}$

Concrete Cover = 40mm		Characteristic load resistance in case of fire $N_{Rk,fire}$ [kN]						
\varnothing [mm]	lv [mm]	R30	R60	R90	R120	R180	R240	
20	200	40,6	31,0	24,5	18,9	11,9	7,5	
	230	47,1	37,5	31,0	25,4	18,0	12,2	
	260	53,6	44,0	37,5	31,9	24,7	18,9	
	290	60,1	50,5	44,0	38,4	31,2	25,4	
	320	66,6	57,0	50,5	44,9	37,7	31,9	
	350	73,1	63,5	57,0	51,4	44,2	38,4	
	380	79,6	70,0	63,5	57,9	50,7	44,9	
	410	86,1	76,5	70,0	64,4	57,2	51,4	
	440	92,6	83,0	76,5	70,9	63,8	57,9	
	470	99,1	89,5	83,0	77,4	70,3	64,4	
	500	105,6	96,0	89,5	83,9	76,8	70,9	
	530	112,1	102,5	96,0	90,4	83,3	77,4	
	560	118,6	109,0	102,5	96,9	89,8	83,9	
	590	125,1	115,5	109,0	103,4	96,3	90,4	
	620	131,6	122,0	115,5	109,9	102,8	96,9	
	650	138,1	128,5	122,0	116,4	109,3	103,4	
	680	144,6	135,0	128,5	122,9	115,8	109,9	
	710	151,1	141,5	135,0	129,4	122,3	116,4	
	740			148,0	141,5	135,9	128,8	122,9
	770			154,6	148,1	142,4	135,3	129,4
790				152,4	146,8	139,6	133,8	
820					153,3	146,1	140,3	
840		157,1				150,5	144,6	
870			157,1	157,1	157,1	157,0	151,1	
880							153,3	
900						157,1	157,1	

Report on fire evaluation of post installed rebar connections with fischer FIS V Plus / FIS V Plus Low Speed injection system

Table 24: beam-wall connection for $c_{nom,min} = 40\text{mm}$ and $\varnothing 25\text{mm}$

Concrete Cover = 40mm		Characteristic load resistance in case of fire $N_{Rk,fire}$ [kN]					
\varnothing [mm]	lv [mm]	R30	R60	R90	R120	R180	R240
25	250	64,9	52,4	43,4	36,2	26,7	18,5
	280	73,1	60,5	51,6	44,3	34,8	27,0
	310	81,2	68,6	59,7	52,4	43,0	35,1
	340	89,3	76,8	67,8	60,6	51,1	43,3
	370	97,5	84,9	76,0	68,7	59,2	51,4
	400	105,6	93,0	84,1	76,8	67,3	59,5
	430	113,7	101,2	92,2	84,9	75,5	67,7
	460	121,8	109,3	100,3	93,1	83,6	75,8
	490	130,0	117,4	108,5	101,2	91,7	83,9
	520	138,1	125,5	116,6	109,3	99,9	92,0
	550	146,2	133,7	124,7	117,5	108,0	100,2
	580	154,4	141,8	132,9	125,6	116,1	108,3
	610	162,5	149,9	141,0	133,7	124,2	116,4
	640	170,6	158,1	149,1	141,8	132,4	124,6
	670	178,7	166,2	157,2	150,0	140,5	132,7
	700	186,9	174,3	165,4	158,1	148,6	140,8
	730	195,0	182,4	173,5	166,2	156,8	148,9
	760	203,1	190,6	181,6	174,4	164,9	157,1
	790	211,3	198,7	189,8	182,5	173,0	165,2
	820	219,4	206,8	197,9	190,6	181,1	173,3
	850	227,5	215,0	206,0	198,7	189,3	181,5
	880	235,6	223,1	214,1	206,9	197,4	189,6
	910	243,8	231,2	222,3	215,0	205,5	197,7
	920			233,9	225,0	217,7	208,2
950			242,1	233,1	225,8	216,4	208,6
970				238,5	231,3	221,8	214,0
1000		245,4			239,4	229,9	222,1
1030			245,4			238,1	230,2
1060				245,4			238,4
1090					245,4		245,4

Report on fire evaluation of post installed rebar connections with fischer FIS V Plus / FIS V Plus Low Speed injection system

Table 25: beam-wall connection for $c_{nom,min} = 40\text{mm}$ and $\varnothing 28\text{mm}$

Concrete Cover = 40mm		Characteristic load resistance in case of fire $N_{Rk,fire}$ [kN]						
\varnothing [mm]	lv [mm]	R30	R60	R90	R120	R180	R240	
28	280	82,3	68,0	57,7	48,9	38,2	28,9	
	310	91,4	77,1	66,8	58,0	47,3	38,0	
	340	100,5	86,2	75,9	67,1	56,4	47,1	
	370	109,6	95,3	85,0	76,2	65,6	56,2	
	400	118,7	104,4	94,1	85,3	74,7	65,3	
	430	127,8	113,5	103,2	94,4	83,8	74,4	
	460	136,9	122,6	112,3	103,6	92,9	83,5	
	490	146,0	131,7	121,4	112,7	102,0	92,6	
	520	155,1	140,8	130,5	121,8	111,1	101,7	
	550	164,2	149,9	139,6	130,9	120,2	110,9	
	580	173,3	159,0	148,7	140,0	129,3	120,0	
	610	182,4	168,2	157,8	149,1	138,4	129,1	
	640	191,5	177,3	166,9	158,2	147,5	138,2	
	670	200,6	186,4	176,0	167,3	156,6	147,3	
	700	209,7	195,5	185,2	176,4	165,7	156,4	
	730	218,8	204,6	194,3	185,5	174,8	165,5	
	760	227,9	213,7	203,4	194,6	183,9	174,6	
	790	237,0	222,8	212,5	203,7	193,0	183,7	
	820	246,1	231,9	221,6	212,8	202,1	192,8	
	850	255,2	241,0	230,7	221,9	211,2	201,9	
	880	264,3	250,1	239,8	231,0	220,3	211,0	
	910	273,4	259,2	248,9	240,1	229,4	220,1	
	940	282,5	268,3	258,0	249,2	238,5	229,2	
	970	291,7	277,4	267,1	258,3	247,6	238,3	
	1000	300,8	286,5	276,2	267,4	256,7	247,4	
	1030	307,9	307,9	295,6	285,3	276,5	265,8	256,5
	1060			304,7	294,4	285,6	275,0	265,6
	1080			307,9	300,5	291,7	281,0	271,7
1110	307,9				300,8	290,1	280,8	
1140				307,9	299,2	289,9		
1170					307,9	299,0		
1200	307,9							

Report on fire evaluation of post installed rebar connections with fischer FIS V Plus / FIS V Plus Low Speed injection system

6.2.5. Maximum applicable loads for a beam-wall connection with a concrete cover of 55mm

Table 26: beam-wall connection for $C_{nom,min} = 55\text{mm}$ and $\varnothing 8\text{mm}$

Concrete Cover = 55mm		Characteristic load resistance in case of fire $N_{Rk,fire}$ [kN]						
\varnothing [mm]	l_v [mm]	R30	R60	R90	R120	R180	R240	
8	100	7,3	4,3	2,3	1,1	0,5	0,2	
	110	8,2	5,1	2,8	1,2	0,6	0,3	
	140	10,8	7,7	5,6	3,7	2,0	1,1	
	170	13,4	10,3	8,2	6,3	3,8	2,2	
	200	16,0	12,9	10,8	8,9	6,5	4,4	
	230	18,6	15,5	13,4	11,5	9,1	6,8	
	260	21,2	18,1	16,0	14,1	11,7	9,5	
	290	23,8	20,7	18,6	16,7	14,3	12,1	
	310	25,1	25,1	22,5	20,4	18,4	16,1	13,8
	340			23,0	21,1	18,7	16,4	
	370			23,7	21,3	19,0		
	390			25,1	23,0	20,8		
	420				25,1	23,4		
	440					25,1		

Report on fire evaluation of post installed rebar connections with fischer FIS V Plus / FIS V Plus Low Speed injection system

Table 27: beam-wall connection for $C_{nom,min} = 55\text{mm}$ and $\varnothing 10\text{mm}$

Concrete Cover = 55mm		Characteristic load resistance in case of fire $N_{Rk,fire}$ [kN]							
\varnothing [mm]	l_v [mm]	R30	R60	R90	R120	R180	R240		
10	100	9,3	5,5	2,9	1,3	0,7	0,3		
	110	10,3	6,4	3,5	1,5	0,8	0,3		
	140	13,6	9,8	7,0	4,6	2,5	1,3		
	170	16,8	13,1	10,3	7,8	4,7	2,7		
	200	20,1	16,3	13,5	11,1	8,1	5,4		
	230	23,3	19,6	16,8	14,3	11,3	8,3		
	260	26,6	22,8	20,0	17,6	14,6	11,7		
	290	29,8	26,1	23,3	20,8	17,9	15,0		
	320	33,1	29,3	26,5	24,1	21,1	18,2		
	350	36,3	32,6	29,8	27,3	24,4	21,5		
	380	39,3	39,3	35,8	33,0	30,6	27,6	24,7	
	410			39,1	36,3	33,9	30,9	28,0	
	420			39,3	39,3	37,4	34,9	31,9	29,1
	440					37,1	34,1	31,2	
	460			39,3	39,3	39,3	39,3	36,3	33,4
	490							39,3	36,7
520	39,3								

Report on fire evaluation of post installed rebar connections with fischer FIS V Plus / FIS V Plus Low Speed injection system

Table 28: beam-wall connection for $C_{nom,min} = 55\text{mm}$ and $\varnothing 12\text{mm}$

Concrete Cover = 55mm		Characteristic load resistance in case of fire $N_{Rk,fire}$ [kN]						
\varnothing [mm]	lv [mm]	R30	R60	R90	R120	R180	R240	
12	100	11,3	6,6	3,5	1,6	0,8	0,3	
	110	12,6	7,8	4,2	1,8	1,0	0,4	
	140	16,5	11,8	8,4	5,5	3,0	1,6	
	170	20,4	15,7	12,3	9,3	5,5	3,2	
	200	24,3	19,7	16,2	13,3	9,5	6,3	
	230	28,2	23,6	20,1	17,2	13,4	9,8	
	260	32,1	27,5	24,1	21,1	17,3	13,9	
	290	36,0	31,4	28,0	25,0	21,2	17,8	
	320	39,9	35,3	31,9	28,9	25,1	21,7	
	350	43,8	39,2	35,8	32,8	29,0	25,6	
	380	47,7	43,1	39,7	36,7	32,9	29,5	
	410	51,6	47,0	43,6	40,6	36,8	33,4	
	440	55,5	50,9	47,5	44,5	40,7	37,3	
	450	56,5	56,5	52,2	48,8	45,8	42,0	38,6
	480			56,1	52,7	49,7	45,9	42,5
	490			54,0	51,0	47,3	43,8	
	510							53,6
	540			56,5	53,8	50,3		
570	56,5						56,5	54,2
590				56,5				

Report on fire evaluation of post installed rebar connections with fischer FIS V Plus / FIS V Plus Low Speed injection system

Table 29: beam-wall connection for $C_{nom,min} = 55\text{mm}$ and $\varnothing 14\text{mm}$

Concrete Cover = 55mm		Characteristic load resistance in case of fire $N_{Rk,fire}$ [kN]						
\varnothing [mm]	lv [mm]	R30	R60	R90	R120	R180	R240	
14	140	19,4	13,9	10,1	6,4	3,4	1,8	
	170	23,9	18,5	14,6	10,7	6,3	3,7	
	200	28,5	23,0	19,2	15,4	10,9	7,2	
	230	33,0	27,6	23,7	19,9	15,5	11,2	
	260	37,6	32,1	28,3	24,5	20,0	16,0	
	290	42,2	36,7	32,8	29,0	24,6	20,6	
	320	46,7	41,2	37,4	33,6	29,1	25,1	
	350	51,3	45,8	41,9	38,1	33,7	29,7	
	380	55,8	50,4	46,5	42,7	38,2	34,2	
	410	60,4	54,9	51,0	47,2	42,8	38,8	
	440	64,9	59,5	55,6	51,8	47,3	43,3	
	470	69,5	64,0	60,1	56,3	51,9	47,9	
	500	74,0	68,6	64,7	60,9	56,4	52,4	
	520	77,0	77,0	71,6	67,7	63,9	59,5	55,5
	550			76,1	72,3	68,5	64,0	60,0
	560			73,8	70,0	65,5	61,6	
	590							74,6
	610			77,0	77,0	77,0	73,1	69,1
640	77,0						73,7	
670							77,0	

Report on fire evaluation of post installed rebar connections with fischer FIS V Plus / FIS V Plus Low Speed injection system

Table 30: beam-wall connection for $C_{nom,min} = 55\text{mm}$ and $\varnothing 16\text{mm}$

Concrete Cover = 55mm		Characteristic load resistance in case of fire $N_{Rk,fire}$ [kN]						
\varnothing [mm]	lv [mm]	R30	R60	R90	R120	R180	R240	
16	160	25,8	19,5	14,9	10,5	6,1	3,5	
	190	31,0	24,7	20,1	15,7	10,3	6,4	
	220	36,2	29,9	25,3	20,9	15,8	11,2	
	250	41,4	35,1	30,5	26,1	21,0	16,2	
	280	46,6	40,3	35,7	31,3	26,2	21,5	
	310	51,8	45,5	40,9	36,5	31,4	26,7	
	340	57,0	50,7	46,2	41,7	36,6	31,9	
	370	62,2	55,9	51,4	47,0	41,8	37,1	
	400	67,4	61,1	56,6	52,2	47,0	42,3	
	430	72,6	66,3	61,8	57,4	52,2	47,5	
	460	77,8	71,5	67,0	62,6	57,4	52,7	
	490	83,0	76,7	72,2	67,8	62,6	57,9	
	520	88,2	82,0	77,4	73,0	67,8	63,1	
	550	93,4	87,2	82,6	78,2	73,0	68,3	
	580	98,6	92,4	87,8	83,4	78,2	73,5	
	600	100,5	100,5	95,8	91,2	86,8	81,7	77,0
	630			100,5	96,4	92,0	86,9	82,2
	660				100,5	97,2	92,1	87,4
680	95,6			90,9				
710	100,5			96,1				
740				100,5				

Report on fire evaluation of post installed rebar connections with fischer FIS V Plus / FIS V Plus Low Speed injection system

Table 31: beam-wall connection for $c_{nom,min} = 55\text{mm}$ and $\varnothing 20\text{mm}$

Concrete Cover = 55mm		Characteristic load resistance in case of fire $N_{Rk,fire}$ [kN]						
\varnothing [mm]	lv [mm]	R30	R60	R90	R120	R180	R240	
20	200	41,3	33,5	27,4	21,7	14,8	9,5	
	230	47,8	40,0	33,9	28,2	21,3	14,9	
	260	54,3	46,5	40,4	34,7	27,8	21,7	
	290	60,8	53,0	46,9	41,2	34,3	28,2	
	320	67,3	59,5	53,4	47,7	40,8	34,7	
	350	73,8	66,0	59,9	54,2	47,3	41,2	
	380	80,3	72,5	66,4	60,7	53,8	47,7	
	410	86,8	79,0	72,9	67,2	60,3	54,2	
	440	93,3	85,5	79,4	73,7	66,9	60,7	
	470	99,8	92,0	85,9	80,2	73,4	67,2	
	500	106,3	98,5	92,4	86,7	79,9	73,7	
	530	112,8	105,0	98,9	93,2	86,4	80,2	
	560	119,4	111,5	105,4	99,7	92,9	86,7	
	590	125,9	118,0	111,9	106,2	99,4	93,2	
	620	132,4	124,5	118,4	112,7	105,9	99,7	
	650	138,9	131,0	124,9	119,2	112,4	106,2	
	680	145,4	137,5	131,5	125,7	118,9	112,7	
	710	151,9	144,0	138,0	132,2	125,4	119,2	
	740		157,1	150,5	144,5	138,7	131,9	125,7
	750			152,7	146,6	140,9	134,1	127,9
780		157,1		153,1	147,4	140,6	134,4	
800				157,1	151,7	144,9	138,7	
830		157,1			151,4	145,2		
860					157,1	151,7	151,7	
890		157,1				157,1	157,1	

Report on fire evaluation of post installed rebar connections with fischer FIS V Plus / FIS V Plus Low Speed injection system

Table 32: beam-wall connection for $c_{nom,min} = 55\text{mm}$ and $\varnothing 25\text{mm}$

Concrete Cover = 55mm		Characteristic load resistance in case of fire $N_{Rk,fire}$ [kN]					
\varnothing [mm]	lv [mm]	R30	R60	R90	R120	R180	R240
25	250	65,9	56,0	47,8	40,2	31,2	22,7
	280	74,0	64,1	56,0	48,4	39,3	31,2
	310	82,1	72,3	64,1	56,5	47,4	39,3
	340	90,3	80,4	72,2	64,6	55,6	47,5
	370	98,4	88,5	80,3	72,8	63,7	55,6
	400	106,5	96,7	88,5	80,9	71,8	63,7
	430	114,7	104,8	96,6	89,0	80,0	71,8
	460	122,8	112,9	104,7	97,1	88,1	80,0
	490	130,9	121,0	112,9	105,3	96,2	88,1
	520	139,1	129,2	121,0	113,4	104,3	96,2
	550	147,2	137,3	129,1	121,5	112,5	104,4
	580	155,3	145,4	137,2	129,7	120,6	112,5
	610	163,4	153,6	145,4	137,8	128,7	120,6
	640	171,6	161,7	153,5	145,9	136,9	128,7
	670	179,7	169,8	161,6	154,1	145,0	136,9
	700	187,8	177,9	169,8	162,2	153,1	145,0
	730	196,0	186,1	177,9	170,3	161,2	153,1
	760	204,1	194,2	186,0	178,4	169,4	161,3
	790	212,2	202,3	194,2	186,6	177,5	169,4
	820	220,3	210,5	202,3	194,7	185,6	177,5
	850	228,5	218,6	210,4	202,8	193,8	185,7
	880	236,6	226,7	218,5	211,0	201,9	193,8
	910	244,7	234,9	226,7	219,1	210,0	201,9
	920			237,6	229,4	221,8	204,6
	950				237,5	229,9	212,7
980					238,1	220,9	
1010		245,4				237,1	229,0
1040			245,4	245,4		245,2	237,1
1050					245,4		239,8
1080						245,4	245,4

Report on fire evaluation of post installed rebar connections with fischer FIS V Plus / FIS V Plus Low Speed injection system

Table 33: beam-wall connection for $C_{nom,min} = 55\text{mm}$ and $\varnothing 28\text{mm}$

Concrete Cover = 55mm		Characteristic load resistance in case of fire $N_{Rk,fire}$ [kN]						
\varnothing [mm]	lv [mm]	R30	R60	R90	R120	R180	R240	
28	280	83,5	72,4	63,0	54,4	43,2	33,8	
	310	92,6	81,5	72,1	63,5	52,3	42,9	
	340	101,7	90,6	81,2	72,6	61,5	52,0	
	370	110,8	99,7	90,3	81,7	70,6	61,1	
	400	119,9	108,8	99,5	90,8	79,7	70,2	
	430	129,0	117,9	108,6	99,9	88,8	79,3	
	460	138,1	127,0	117,7	109,0	97,9	88,4	
	490	147,2	136,2	126,8	118,1	107,0	97,5	
	520	156,3	145,3	135,9	127,2	116,1	106,6	
	550	165,4	154,4	145,0	136,3	125,2	115,7	
	580	174,5	163,5	154,1	145,4	134,3	124,8	
	610	183,7	172,6	163,2	154,5	143,4	133,9	
	640	192,8	181,7	172,3	163,6	152,5	143,1	
	670	201,9	190,8	181,4	172,7	161,6	152,2	
	700	211,0	199,9	190,5	181,9	170,7	161,3	
	730	220,1	209,0	199,6	191,0	179,8	170,4	
	760	229,2	218,1	208,7	200,1	188,9	179,5	
	790	238,3	227,2	217,8	209,2	198,0	188,6	
	820	247,4	236,3	226,9	218,3	207,1	197,7	
	850	256,5	245,4	236,0	227,4	216,2	206,8	
	880	265,6	254,5	245,1	236,5	225,3	215,9	
	910	274,7	263,6	254,2	245,6	234,4	225,0	
	940	283,8	272,7	263,3	254,7	243,5	234,1	
	970	292,9	281,8	272,4	263,8	252,6	243,2	
	1000	302,0	290,9	281,5	272,9	261,7	252,3	
	1020	307,9	307,9	297,0	287,6	279,0	267,8	258,4
	1050			306,1	296,7	288,1	276,9	267,5
	1060			307,9	299,7	291,1	280,0	270,5
1090	300,2				289,1	279,6		
1120	307,9			307,9	307,9	298,2	288,7	
1150						307,3	297,8	
1160						307,9	300,9	
1190							307,9	

7. References

- [1] 18048HK/15562_1: Report on fire tests for post installed rebars according to EAD 330087-00-0601 with the fischer FIS V 360 S injection system August 2018.
- [2] DIN EN 1992-1-2, 2010-12: Eurocode 2: Design of concrete structures - Part 1-2: General rules - Structural fire design; German version EN 1992-1-2:2004 + AC:2008.
- [3] DIN EN 1993-1-2, 2010-12: Eurocode 3: Design of steel structures - Part 1-2: General rules - Structural fire design; German version EN 1993-1-2:2005 + AC:2009.
- [4] DIN EN 1363-1, 2012-10: Fire resistance tests - Part 1: General Requirements.
- [5] DIN EN 1992-1-1, 2011-01: Eurocode 2: Design of concrete structures - Part 1-1: General rules and rules for buildings.
- [6] ISO 834-1:1999: Fire resistance tests - Elements of building construction - Part 1: General requirements.
- [7] 20037HK/15511_3: Assessment of heating sleeve tests with fischer injection systems FIS V in mixing ratio 10:1 respectively FIS V Plus and FIS V in mixing ratio 5:1 in different versions according to EAD 330087-00-0601 November 2020.

Assessment Report

Project **22044_enshort**

**Fire resistance of fischer injection system FIS V
Plus under fire exposure acc. to DIN EN 1363-1**

Employer **Fischerwerke GmbH & Co. KG
Otto-Hahn-Straße 15
D – 79211 Denzlingen**

Pages **15**

Author

INGENIEURBÜRO THIELE
TRAGWERKSPLANUNG GMBH

UNTERER SOMMERWALDWEG 1
TRAGWERK@INGENIEURBUERO THIELE .DE

66953 PIRMASENS
TEL. 06331 55470

Table of contents

1	General information.....	3
2	Reference documents	3
3	Product description	4
4	Scope of evaluation.....	4
5	Fire resistance loads for threaded rods.....	5
5.1	Galvanized steel	5
5.2	Stainless steel.....	10

1 General information

Fischerwerke GmbH & Co. KG authorized the evaluation of the fire resistance of the chemical anchor system FIS V Plus for axial tension and shear loads. The evaluation is based on tests that were conducted by the Technical University Kaiserslautern under fire exposure according to DIN EN 1363-1:2012 [2] and Technical Report TR020 [1]. The following document is based on the test results of the test report 18049HK15563 [3] and the expertise "Project 20037HK/15511_3" [7].

This evaluation provides fire resistances, which cover anchors with fire attack from one side only.

2 Reference documents

- [1] Evaluation of Anchorages in Concrete Concerning Resistance to fire, EOTA TR020, Edition May 2004
 - [2] Feuerwiderstandsprüfungen – Teil 1: Allgemeine Anforderungen, DIN EN 1363-1; Edition Oktober 2012
 - [3] Report on fire tests according to TR020 with FIS V 360 S adhesive, Test Report 18049HK15563, TU Kaiserslautern, April 2019
 - [4] Europäisch Technische Bewertung ETA-20/0603: "fischer Injektionssystem FIS V plus", EOTA, DIBt, November 2020
 - [5] C. Thiele, M. Reichert: "Qualifikation von Verbunddübeln im Brandfall", TU Kaiserslautern, DIBt, June 2017
 - [6] Report on fire tests for post installed rebars according to EAD 330087-00-0601 with the fischer FIS V, fischer FIS VS and fischer VW injection system, TU Kaiserslautern, Dezember 2018
 - [7] Assessment of heating sleeve tests with fischer injection systems FIS V in mixing ratio 10:1 respectively FIS V Plus and FIS V in mixing ratio 5:1 in different versions according to EAD 330087-00-0601, Project 20037HK/15511_3, TU Kaiserslautern, November 2020
-

3 Product description

The fischer FIS V Plus adhesive is a bonded anchor system in a 2 component cartridge system for use in cracked and non-cracked normal weight concrete. Due to the almost identical high temperature properties of the fischer FIS V Plus, fischer FIS V Plus Low Speed and fischer FIS V Plus High Speed injection system, the report applies to all mentioned products [6].

The injection system FIS V Plus is designed for the use in concrete according to the European Technical Assessment ETA-20/0603 [4].

4 Scope of evaluation

The present evaluation of fire resistance for fischer FIS V Plus anchor system in concrete is assessed with respect to its fire resistance properties as anchor applications in walls and ceilings. The tests, which this evaluation refers to, are executed with vertical arranged anchors and axial load application. Furthermore, the anchors were exposed to the standard temperature-time curve (ETK) [2]. In the tests a fixture according to TR020 [1] was used, therefore the following fire resistances cover only anchors protected from fire by attachments similar to the fixture according to TR020 [1].

The assessment of steel failure is carried out in dependence on “Qualifizierung von Verbunddübeln im Brandfall” [5] which is based on the TR020 [1]. The assessment of concrete cone failure is carried out in dependence on TR020 [1]. Additionally the failure type pullout failure is assessed.

- a. Steel failure:
Steel failure is assessed according to the research report “Qualifikation von Verbunddübeln im Brandfall” [5].
- b. Pullout failure:
Pullout failure is assessed by the current state of scientific knowledge according to the research report “Qualifikation von Verbunddübeln im Brandfall” [5] A combination of thermal simulation and assessment of test results was used.
- c. Concrete cone failure:
Concrete cone failure is assessed according to TR020 [1].

The fire resistances, which are given in chapter 5 cover axial loads and shear loads as well.

5 Fire resistance loads for threaded rods

5.1 Galvanized steel

Table 5-1 to Table 5-4 are showing the decisive fire resistances of the injection system FIS V Plus for use in **cracked** and **non-cracked concrete** for pullout, steel and concrete failure. The given fire resistances cover axial and shear loads.

The listed fire resistances are valid for single anchors with an edge distance of more than $c_{cr,fi}=2 h_{ef}$ and a spacing to the adjacent anchor of $s= 2 c_{cr,fi}= 4 h_{ef}$. Edge and spacing distances have to be chosen so that steel – or pullout failure are decisive.

The values below are valid for the use of carbon steel (minimum grade 5.8 acc. to ISO 898-1).

For the grey coloured values steel failure is decisive.

Table 5-1: Summary of the characteristic resistance for **non-cracked** concrete, M8-M20

Anchorage depth h_{ef}	Anchorage size	Maximum characteristic tension load $N_{Rk,fi(t)}$ and shear load $V_{Rk,fi(t)}$ [kN] depending on the fire resistance time			
		30 [min]	60 [min]	90 [min]	120 [min]
[mm]	[mm]	[kN]	[kN]	[kN]	[kN]
75	8	0,73	0,55	0,39	0,08
80		0,73	0,55	0,40	0,19
85		0,73	0,55	0,40	0,33
75	10	1,45	1,10	0,28	0,00
80		1,45	1,10	0,47	0,08
85		1,45	1,10	0,72	0,22
90		1,45	1,10	0,81	0,39
95		1,45	1,10	0,81	0,60
100		1,45	1,10	0,81	0,64
85	12	2,53	1,89	0,56	0,08
90		2,53	1,94	0,85	0,25
95		2,53	1,94	1,22	0,45
100		2,53	1,94	1,35	0,70
105		2,53	1,94	1,35	1,01
110		2,53	1,94	1,35	1,10
115	16	2,53	1,94	1,35	1,10
95		4,71	2,53	0,76	0,10
100		4,71	3,38	1,14	0,34
105		4,71	3,61	1,62	0,60
110		4,71	3,61	2,20	0,92
115		4,71	3,61	2,51	1,32
120		4,71	3,61	2,51	1,81
125		4,71	3,61	2,51	2,04
130	4,71	3,61	2,51	2,04	
105	20	7,35	3,38	1,06	0,16
110		7,35	4,43	1,54	0,47
115		7,35	5,64	2,13	0,80
120		7,35	5,64	2,86	1,22
125		7,35	5,64	3,71	1,71
130		7,35	5,64	3,92	2,30
135		7,35	5,64	3,92	3,02
140		7,35	5,64	3,92	3,19
145		7,35	5,64	3,92	3,19

Table 5-2: Summary of the characteristic resistance for **non-cracked** concrete, M24-M30

Anchorage depth h_{ef}	Anchorage size	Maximum characteristic tension load $N_{Rk,fi(t)}$, and shear load $V_{Rk,fi(t)}$, [kN] depending on the fire resistance time			
		30 [min]	60 [min]	90 [min]	120 [min]
[mm]	[mm]	[kN]	[kN]	[kN]	[kN]
115	24	10,59	4,49	1,45	0,27
120		10,59	5,74	2,04	0,65
125		10,59	7,21	2,77	1,07
130		10,59	8,12	3,63	1,57
135		10,59	8,12	4,65	2,17
140		10,59	8,12	5,65	2,88
145		10,59	8,12	5,65	3,72
150		10,59	8,12	5,65	4,59
155		10,59	8,12	5,65	4,59
160		10,59	8,12	5,65	4,59
120		27	13,77	4,87	1,53
125	13,77		6,20	2,16	0,63
130	13,77		7,73	2,91	1,08
135	13,77		9,49	3,81	1,61
140	13,77		10,56	4,87	2,22
145	13,77		10,56	6,10	2,97
150	13,77		10,56	7,34	3,82
155	13,77		10,56	7,34	4,83
160	13,77		10,56	7,34	5,97
165	13,77		10,56	7,34	5,97
170	13,77	10,56	7,34	5,97	
120	30	16,83	4,13	1,05	0,00
125		16,83	5,34	1,63	0,11
130		16,83	6,75	2,29	0,59
135		16,83	8,38	3,10	1,09
140		16,83	10,24	4,04	1,65
145		16,83	12,37	5,15	2,31
150		16,83	12,90	6,43	3,08
155		16,83	12,90	7,90	3,97
160		16,83	12,90	8,98	5,01
165		16,83	12,90	8,98	6,21
170		16,83	12,90	8,98	7,29
175		16,83	12,90	8,98	7,29
180		16,83	12,90	8,98	7,29

Table 5-3: Summary of the characteristic resistance for **cracked** concrete, M10-M20

Anchorage depth h_{ef}	Anchorage size	Maximum characteristic tension load $N_{Rk,fi(t)}$, and shear load $V_{Rk,fi(t)}$, [kN] depending on the fire resistance time			
		30 [min]	60 [min]	90 [min]	120 [min]
[mm]	[mm]	[kN]	[kN]	[kN]	[kN]
75	10	1,45	0,85	0,21	0,00
80		1,45	1,10	0,35	0,06
85		1,45	1,10	0,54	0,17
90		1,45	1,10	0,78	0,29
95		1,45	1,10	0,81	0,45
100		1,45	1,10	0,81	0,64
85	12	2,53	1,42	0,42	0,06
90		2,53	1,93	0,64	0,19
95		2,53	1,94	0,92	0,34
100		2,53	1,94	1,27	0,53
105		2,53	1,94	1,35	0,76
110		2,53	1,94	1,35	1,05
115		2,53	1,94	1,35	1,10
95	16	4,71	1,90	0,57	0,07
100		4,71	2,54	0,86	0,25
105		4,71	3,30	1,21	0,45
110		4,71	3,61	1,65	0,69
115		4,71	3,61	2,19	0,99
120		4,71	3,61	2,51	1,36
125		4,71	3,61	2,51	1,80
130		4,71	3,61	2,51	2,04
105	20	7,35	2,54	0,79	0,12
110		7,35	3,32	1,15	0,35
115		7,35	4,25	1,60	0,60
120		7,35	5,32	2,14	0,91
125		7,35	5,64	2,78	1,28
130		7,35	5,64	3,55	1,73
135		7,35	5,64	3,92	2,26
140		7,35	5,64	3,92	2,89
145		7,35	5,64	3,92	3,19

Table 5-4: Summary of the characteristic resistance for **cracked** concrete, M24-M30

Anchorage depth h_{ef}	Anchorage size	Maximum characteristic tension load $N_{Rk,fi(t)}$, and shear load $V_{Rk,fi(t)}$, [kN] depending on the fire resistance time			
		30 [min]	60 [min]	90 [min]	120 [min]
[mm]	[mm]	[kN]	[kN]	[kN]	[kN]
115	24	10,59	3,36	1,09	0,21
120		10,59	4,31	1,53	0,49
125		10,59	5,41	2,08	0,81
130		10,59	6,67	2,72	1,18
135		10,59	8,10	3,49	1,63
140		10,59	8,12	4,38	2,16
145		10,59	8,12	5,40	2,79
150		10,59	8,12	5,65	3,51
155		10,59	8,12	5,65	4,36
160		10,59	8,12	5,65	4,59
120		27	13,77	3,65	1,14
125	13,77		4,65	1,62	0,47
130	13,77		5,79	2,18	0,81
135	13,77		7,11	2,86	1,20
140	13,77		8,63	3,65	1,67
145	13,77		10,34	4,58	2,23
150	13,77		10,56	5,64	2,87
155	13,77		10,56	6,86	3,62
160	13,77		10,56	7,34	4,49
165	13,77		10,56	7,34	5,49
170	13,77	10,56	7,34	5,97	
120	30	14,21	3,10	0,79	0,00
125		16,80	4,01	1,22	0,08
130		16,83	5,06	1,72	0,44
135		16,83	6,29	2,32	0,81
140		16,83	7,68	3,03	1,24
145		16,83	9,28	3,86	1,73
150		16,83	11,05	4,82	2,31
155		16,83	12,90	5,93	2,98
160		16,83	12,90	7,19	3,76
165		16,83	12,90	8,61	4,65
170		16,83	12,90	8,98	5,68
175		16,83	12,90	8,98	6,84
180		16,83	12,90	8,98	7,29

5.2 Stainless steel

Table 5-5 to Table 5-8 are showing the decisive fire resistances of the injection system FIS V Plus for use in **cracked** and **non-cracked concrete** for pullout, steel and concrete failure. The given fire resistances cover axial and shear loads.

The listed fire resistances are valid for single anchors with an edge distance of more than $c_{cr,fi}=2 h_{ef}$ and a spacing to the adjacent anchor of $s= 2 c_{cr,fi}= 4 h_{ef}$. Edge and spacing distances have to be chosen so that steel – or pullout failure are decisive.

The values below are valid for the use of stainless steel (1.4401, 1.4404, 1.4571, 1.4439, 1.4362, 1.4062, 1.4662, 1.4462 acc. to EN 10088, minimum grade 70 acc. to ISO 3506) or high corrosion resistant steel (HCR 1.4529, 1.4565 acc. to EN 10088, minimum grade 70 acc. to ISO 3506) anchor rods.

For the grey coloured values steel failure was decisive.

Table 5-5: Summary of the characteristic resistance for **non-cracked** concrete, M8-M20

Anchorage depth h_{ef}	Anchorage size	Maximum characteristic tension load $N_{Rk,fi(t)}$, and shear load $V_{Rk,fi(t)}$, [kN] depending on the fire resistance time			
		30 [min]	60 [min]	90 [min]	120 [min]
[mm]	[mm]	[kN]	[kN]	[kN]	[kN]
75	8	0,73	0,59	0,39	0,08
80		0,73	0,59	0,44	0,19
85		0,73	0,59	0,44	0,33
90		0,73	0,59	0,44	0,37
75	10	1,45	1,14	0,28	0,00
80		1,45	1,16	0,47	0,08
85		1,45	1,16	0,72	0,22
90		1,45	1,16	0,93	0,39
95		1,45	1,16	0,93	0,60
100		1,45	1,16	0,93	0,81
85	12	2,53	1,89	0,56	0,08
90		2,53	2,11	0,85	0,25
95		2,53	2,11	1,22	0,45
100		2,53	2,11	1,69	0,70
105		2,53	2,11	1,69	1,01
110		2,53	2,11	1,69	1,35
115	16	2,53	2,11	1,69	1,35
95		10,21	2,53	0,76	0,10
100		10,21	3,38	1,14	0,34
105		10,21	4,40	1,62	0,60
110		10,21	5,60	2,20	0,92
115		10,21	6,99	2,92	1,32
120		10,21	7,38	3,78	1,81
125		10,21	7,38	4,55	2,40
130		10,21	7,38	4,55	3,10
135		10,21	7,38	4,55	3,14
105	20	13,66	3,38	1,06	0,16
110		15,93	4,43	1,54	0,47
115		15,93	5,66	2,13	0,80
120		15,93	7,09	2,86	1,22
125		15,93	8,74	3,71	1,71
130		15,93	10,59	4,73	2,30
135		15,93	11,52	5,91	3,02
140		15,93	11,52	7,11	3,85
145		15,93	11,52	7,11	4,84
150		15,93	11,52	7,11	4,90

Table 5-6: Summary of the characteristic resistance for **non-cracked** concrete, M24-M30

Anchorage depth h_{ef}	Anchorage size	Maximum characteristic tension load $N_{Rk,fi(t)}$, and shear load $V_{Rk,fi(t)}$, [kN] depending on the fire resistance time			
		30 [min]	60 [min]	90 [min]	120 [min]
[mm]	[mm]	[kN]	[kN]	[kN]	[kN]
115	24	17,79	4,49	1,45	0,27
120		20,94	5,74	2,04	0,65
125		22,95	7,21	2,77	1,07
130		22,95	8,89	3,63	1,57
135		22,95	10,80	4,65	2,17
140		22,95	12,94	5,83	2,88
145		22,95	15,33	7,20	3,72
150		22,95	16,59	8,77	4,68
155		22,95	16,59	10,24	5,81
160		22,95	16,59	10,24	7,06
120		27	19,91	4,87	1,53
125	23,30		6,20	2,16	0,63
130	26,92		7,73	2,91	1,08
135	29,84		9,49	3,81	1,61
140	29,84		11,50	4,87	2,22
145	29,84		13,78	6,10	2,97
150	29,84		16,24	7,52	3,82
155	29,84		19,02	9,15	4,83
160	29,84		21,57	10,97	5,99
165	29,84		21,57	13,01	7,32
170	29,84		21,57	13,31	8,83
175	29,84	21,57	13,31	9,18	
120	30	18,94	4,13	1,05	0,00
125		22,40	5,34	1,63	0,11
130		26,01	6,75	2,29	0,59
135		30,00	8,38	3,10	1,09
140		34,30	10,24	4,04	1,65
145		36,47	12,37	5,15	2,31
150		36,47	14,74	6,43	3,08
155		36,47	17,39	7,90	3,97
160		36,47	20,28	9,59	5,01
165		36,47	23,44	11,47	6,21
170		36,47	26,37	13,61	7,57
175		36,47	26,37	15,95	9,13
180		36,47	26,37	16,27	10,87
185		36,47	26,37	16,27	11,22

Table 5-7: Summary of the characteristic resistance for **cracked** concrete, M10-M20

Anchorage depth h_{ef}	Anchorage size	Maximum characteristic tension load $N_{Rk,fi(t)}$ and shear load $V_{Rk,fi(t)}$ [kN] depending on the fire resistance time			
		30 [min]	60 [min]	90 [min]	120 [min]
[mm]	[mm]	[kN]	[kN]	[kN]	[kN]
75	10	1,45	0,85	0,21	0,00
80		1,45	1,16	0,35	0,06
85		1,45	1,16	0,54	0,17
90		1,45	1,16	0,78	0,29
95		1,45	1,16	0,93	0,45
100		1,45	1,16	0,93	0,65
105		1,45	1,16	0,93	0,81
85	12	2,53	1,42	0,42	0,06
90		2,53	1,93	0,64	0,19
95		2,53	2,11	0,92	0,34
100		2,53	2,11	1,27	0,53
105		2,53	2,11	1,69	0,76
110		2,53	2,11	1,69	1,05
115		2,53	2,11	1,69	1,35
95	16	7,83	1,90	0,57	0,07
100		9,46	2,54	0,86	0,25
105		10,21	3,30	1,21	0,45
110		10,21	4,20	1,65	0,69
115		10,21	5,24	2,19	0,99
120		10,21	6,42	2,83	1,36
125		10,21	7,38	3,58	1,80
130		10,21	7,38	4,45	2,33
135		10,21	7,38	4,55	2,95
140		10,21	7,38	4,55	3,14
105	20	10,24	2,54	0,79	0,12
110		12,26	3,32	1,15	0,35
115		14,42	4,25	1,60	0,60
120		15,93	5,32	2,14	0,91
125		15,93	6,56	2,78	1,28
130		15,93	7,95	3,55	1,73
135		15,93	9,48	4,43	2,26
140		15,93	11,19	5,46	2,89
145		15,93	11,52	6,62	3,63
150		15,93	11,52	7,11	4,48
155		15,93	11,52	7,11	4,90

Table 5-8: Summary of the characteristic resistance for **cracked** concrete, M24-M30

Anchorage depth h_{ef}	Anchorage size	Maximum characteristic tension load $N_{Rk,fi(t)}$, and shear load $V_{Rk,fi(t)}$, [kN] depending on the fire resistance time			
		30 [min]	60 [min]	90 [min]	120 [min]
[mm]	[mm]	[kN]	[kN]	[kN]	[kN]
115	24	13,35	3,36	1,09	0,21
120		15,71	4,31	1,53	0,49
125		18,24	5,41	2,08	0,81
130		20,98	6,67	2,72	1,18
135		22,95	8,10	3,49	1,63
140		22,95	9,71	4,38	2,16
145		22,95	11,49	5,40	2,79
150		22,95	13,45	6,58	3,51
155		22,95	15,59	7,90	4,36
160		22,95	16,59	9,38	5,33
165		22,95	16,59	10,24	6,44
170		22,95	16,59	10,24	7,06
120	27	14,93	3,65	1,14	0,15
125		17,48	4,65	1,62	0,47
130		20,19	5,79	2,18	0,81
135		23,15	7,11	2,86	1,20
140		26,33	8,63	3,65	1,67
145		29,83	10,34	4,58	2,23
150		29,84	12,18	5,64	2,87
155		29,84	14,27	6,86	3,62
160		29,84	16,52	8,23	4,49
165		29,84	18,95	9,76	5,49
170	29,84	21,55	11,45	6,62	
175	29,84	21,57	13,31	7,90	
180	29,84	21,57	13,31	9,18	
120	30	14,21	3,10	0,79	0,00
125		16,80	4,01	1,22	0,08
130		19,51	5,06	1,72	0,44
135		22,50	6,29	2,32	0,81
140		25,72	7,68	3,03	1,24
145		29,16	9,28	3,86	1,73
150		32,84	11,05	4,82	2,31
155		36,47	13,04	5,93	2,98
160		36,47	15,21	7,19	3,76
165		36,47	17,58	8,61	4,65
170		36,47	20,15	10,20	5,68
175		36,47	22,90	11,96	6,84
180		36,47	25,86	13,89	8,16
185		36,47	26,37	16,01	9,61
190	36,47	26,37	16,27	11,22	

Pirmasens, 26st of November 2020



apl. Prof. Dr.-Ing. Catherina Thiele



Heiner Kruse, M.Sc.