

Monteringsanvisning / Installation instruction

FMM: 100 74 23 - Rev.001

AC omvandlare för nät drift Converter for mains operation

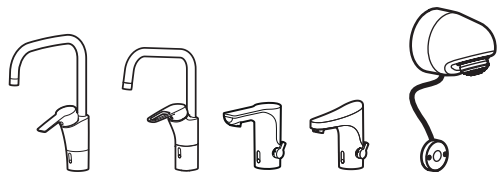

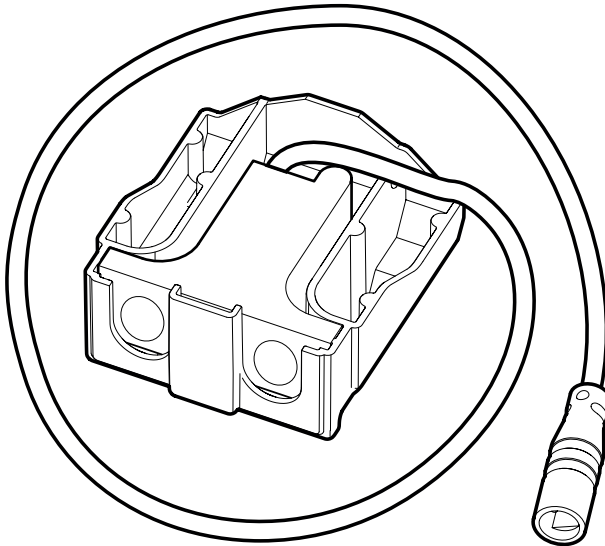

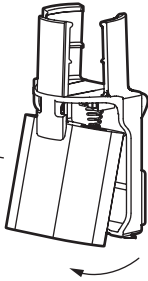
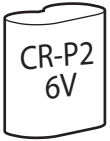

1

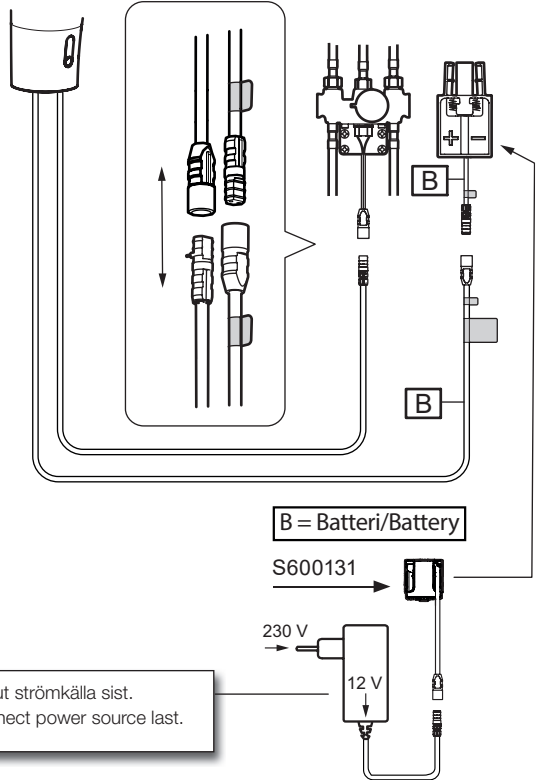

2



 **SV:** Anslut strömkälla sist.
EN: Connect power source last.

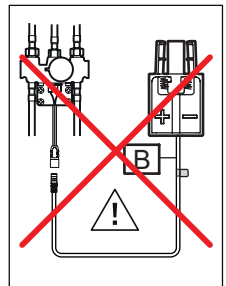
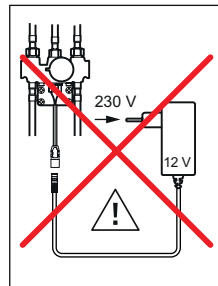
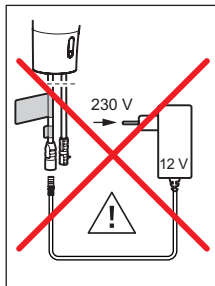

1

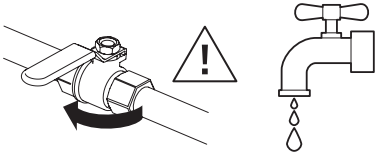

2

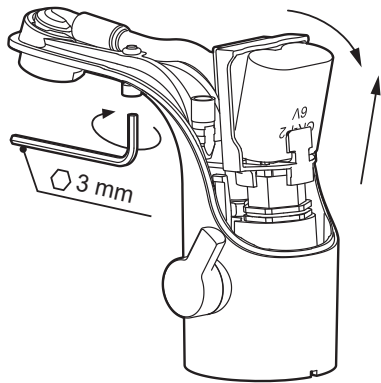
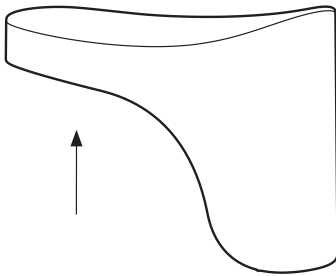

3

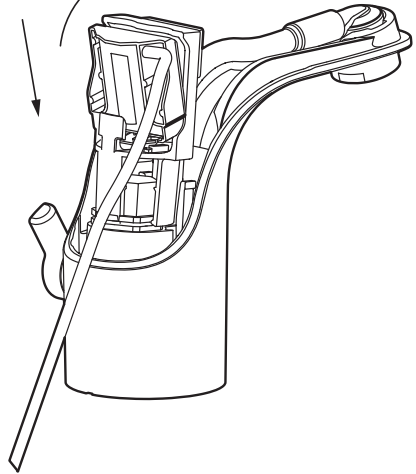



④

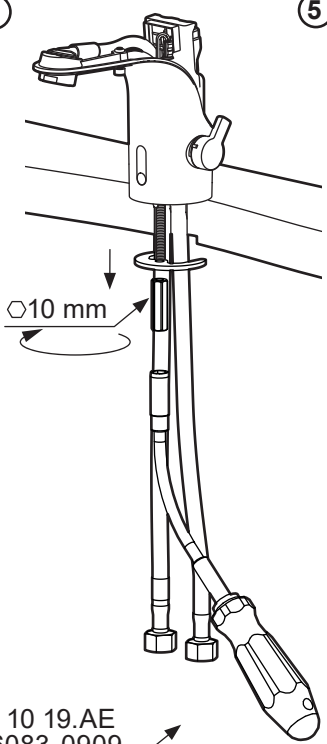

∅10 mm

⑤

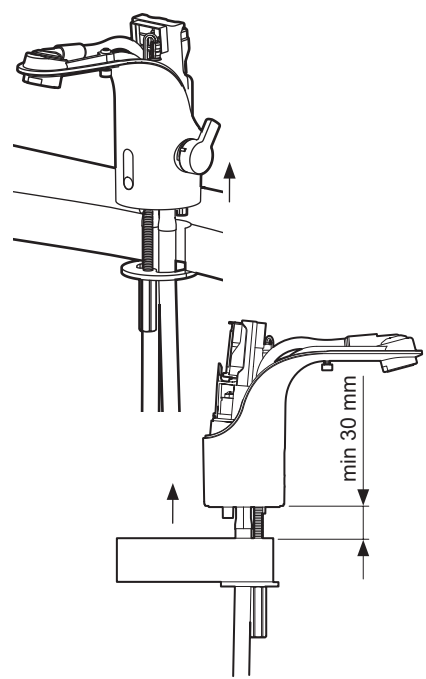

min 30 mm

MA 89 10 19.AE
FMM 6083-0909

⑥

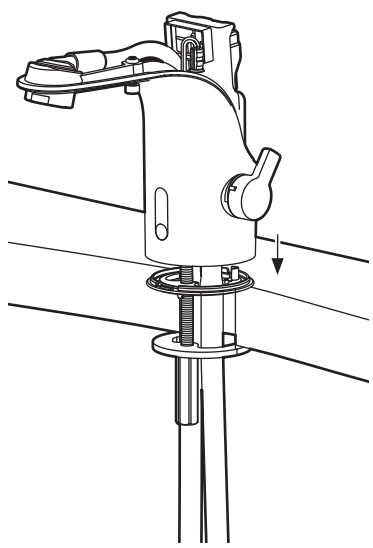

7

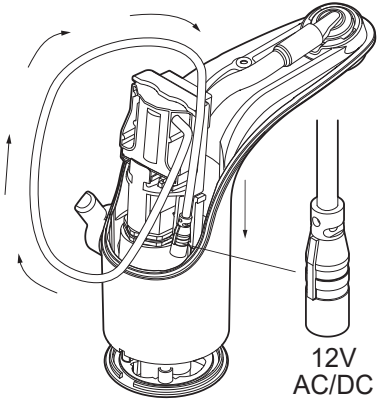

8

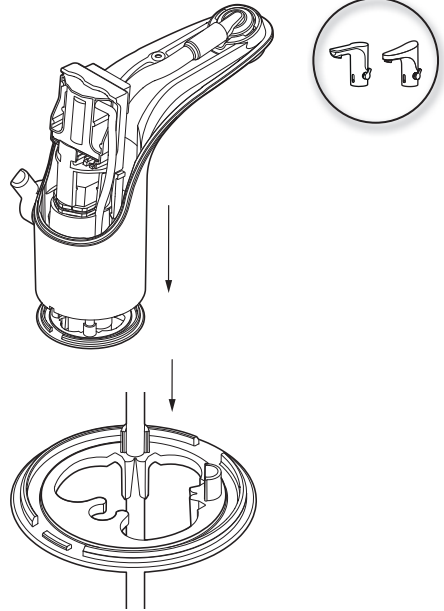

9

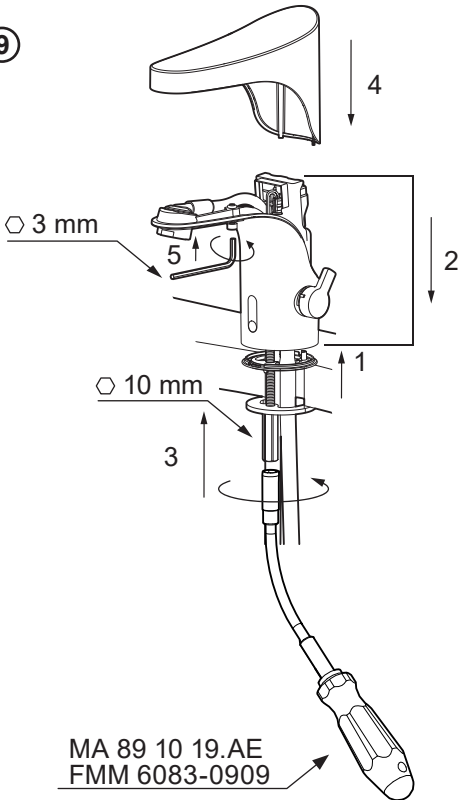

10

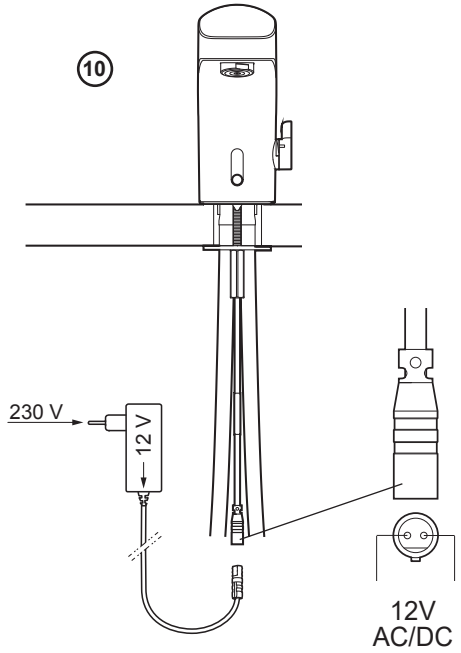

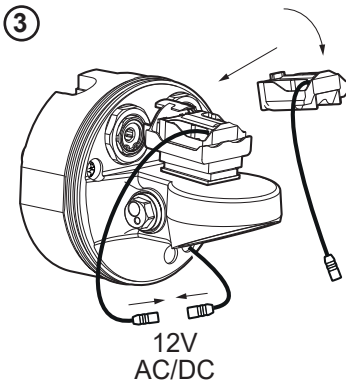
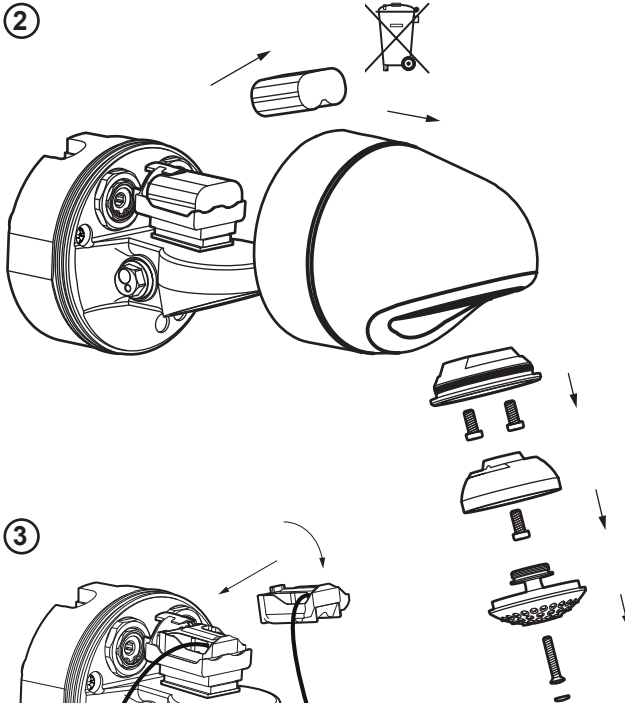
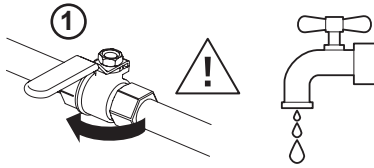

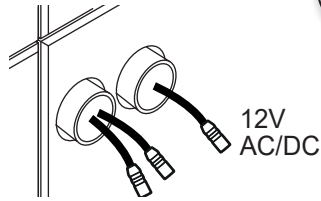
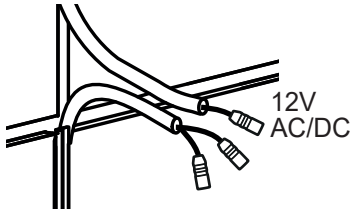

SV

OBS! Kabeln placeras lämpligen i kakelfogen eller i rör, men tänk på att väggens tätningsskikt ej får skadas.

EN

NOTE! The cable should ideally be placed in the joint between wall tiles or in a pipe, but take care not to damage the wall's moisture barrier.

NO

OBS! Kabelen kan plasseres i flisfugen eller i rør, men tenk på at veggens tetningssjikt ikke må skades.

DK

OBS! Kablet placeres hensigtsmæssigt i flisefugen eller i rør, men vær opmærksom på, at væggens tætningslag ikke må beskadiges.

FI

HUOM! Kaapeli kannattaa sijoittaa kaakelisaumaan tai putkeen, mutta seinän tiivistyskerrosta ei saa vaurioittaa.

DE

Hinweis: Die Kabelverlegung erfolgt vorzugsweise in einer Kachelfuge oder in einem Rohr. Beachten Sie jedoch, dass die Dichtungsschicht der Wand nicht beschädigt werden darf.

NL

Let op: De kabel wordt bij voorkeur in de tegelvoeg of in een buis geplaatst, maar let op dat de waterdichte laag van de wand niet beschadigd raakt.

FR

N. B. Placer de préférence le câble dans la jointure d'un carreau ou dans un tube, mais veiller à ne pas endommager la couche d'étanchéité du mur.

