



ETA-Danmark A/S  
Göteborg Plads 1  
DK-2150 Nordhavn  
Tel. +45 72 24 59 00  
Fax +45 72 24 59 04  
Internet [www.etadanmark.dk](http://www.etadanmark.dk)

Authorised and notified according  
to Article 29 of the Regulation (EU)  
No 305/2011 of the European  
Parliament and of the Council of 9  
March 2011

MEMBER OF EOTA



## European Technical Assessment ETA-06/0106 of 24/05/2017

I General Part

**Technical Assessment Body issuing the ETA and designated according to Article 29 of the Regulation (EU) No 305/2011: ETA-Danmark A/S**

**Trade name of the construction product:**

Simpson Strong-Tie Angle Brackets  
See type numbers in section II.1 of the ETA

**Product family to which the above construction product belongs:**

Three-dimensional nailing plate (timber-to-timber/timber-to-concrete angle bracket)

**Manufacturer:**

Simpson Strong-Tie Int. Ltd  
For local branch addresses refer to [www.strongtie.eu](http://www.strongtie.eu)

**Manufacturing plant:**

SIMPSON STRONG-TIE Manufacturing facilities

**This European Technical Assessment contains:**

334 pages including 4 annexes which form an integral part of the document

**This European Technical Assessment is issued in accordance with Regulation (EU) No 305/2011, on the basis of:**

Guideline for European Technical Approval (ETAG) No. 015 Three Dimensional Nailing Plates, April 2013, used as European Assessment Document (EAD).

**This version replaces:**

The ETA with the same number issued on 2016-12-06

<b>II</b>	<b>SPECIAL CONDITIONS OF THE EUROPEAN TECHNICAL ASSESSMENT.....</b>	<b>5</b>
1	TECHNICAL DESCRIPTION OF PRODUCT AND INTENDED USE .....	5
2	SPECIFICATION OF THE INTENDED USE IN ACCORDANCE WITH THE APPLICABLE EAD .....	5
3	CHARACTERISTICS OF PRODUCT AND ASSESSMENT.....	7
4	ASSESSMENT AND VERIFICATION OF CONSTANCY OF PERFORMANCE (AVCP).....	10
5	TECHNICAL DETAILS NECESSARY FOR THE IMPLEMENTATION OF THE AVCP SYSTEM, AS FORESEEN IN THE APPLICABLE EAD.....	10
	<b>ANNEX A - REVISION HISTORY .....</b>	<b>11</b>
	<b>ANNEX B - TYPICAL INSTALLATION.....</b>	<b>14</b>
	<b>ANNEX C - BASIS OF DESIGN.....</b>	<b>18</b>
	ANNEX C1 – BASIS OF DESIGN .....	18
	ANNEX C2 – DEFINITION OF FORCES DIRECTION .....	19
	ANNEX C3 – FASTENERS SPECIFICATION AND CAPACITIES .....	23
	ANNEX C4 – CHARACTERISTIC CAPACITY MODIFICATION METHODS FOR NAILS AND TIMBER TYPES.....	24
	<b>ANNEX D - PRODUCT DEFINITION AND CAPACITIES.....</b>	<b>26</b>
	ANNEX D1 – ABR90 .....	27
	ANNEX D2 – AB90.....	36
	ANNEX D3 – ABR105 .....	42
	ANNEX D4 – AB105.....	51
	ANNEX D5 – ABR70 .....	57
	ANNEX D6 – AB70.....	64
	ANNEX D7 – E20/3.....	66
	ANNEX D8 – E9/2.5.....	74
	ANNEX D9 – E9S/2.5 .....	79
	ANNEX D10 – ABR9015 .....	84
	ANNEX D11 – ABR9020 .....	89
	ANNEX D12 – ABR100 .....	98
	ANNEX D13 – AA60280 .....	103
	ANNEX D14 – ABB40390 .....	105
	ANNEX D15 – AE48.....	109
	ANNEX D16 – AE76.....	114
	ANNEX D17 – AE116.....	120
	ANNEX D18 – AG40312, AG40412, AG40314 & AG40414 .....	128
	ANNEX D19 – AH9035 .....	136
	ANNEX D20 – AJ60416.....	138
	ANNEX D21 – AJ80416.....	140
	ANNEX D22 – AJ99416.....	142
	ANNEX D23 – KNAG90, 130, 170 & 210 .....	144
	ANNEX D24 – ES10 & ES11 .....	150
	ANNEX D25 – LS30, LS50, LS70 & LS90 .....	158
	ANNEX D26 – TA9Z & TA10Z.....	161
	ANNEX D27 – ABR170 & ABR 220 .....	163
	ANNEX D28 – AB6983.....	168
	ANNEX D29 – AB36125.....	170
	ANNEX D30 – BNV33.....	173
	ANNEX D31 – E5/1.5.....	175
	ANNEX D32 – E5/2.....	184
	ANNEX D33 – AT1 .....	190
	ANNEX D34 – E4/2.5.....	197
	ANNEX D35 – E6/2.....	202
	ANNEX D36 – E6/2,5.....	210
	ANNEX D37 – E7/2,5.....	218

ANNEX D38 – E8/2,5.....	227
ANNEX D39 – E14/2.....	236
ANNEX D40 – E17/2.....	240
ANNEX D41 – E18/2,5.....	248
ANNEX D42 – E19/3.....	256
ANNEX D43 – ADR6090.....	265
ANNEX D44 – ADR6035.....	268
ANNEX D45 – ABAl105.....	270
ANNEX D46 – AG922.....	272
ANNEX D47 – ABR10525.....	276
ANNEX D48 – ABR7015.....	282
ANNEX D49 – ACR / ACRL.....	285
ANNEX D50 – MAXIMUS.....	291
ANNEX D51 – AT2.....	294
ANNEX D52 – ABR865.....	296
ANNEX D53 – ACFET200 & ACFET200PP.....	299
ANNEX D54 – ANP.....	300
ANNEX D55 – A-BRACKETS.....	304
ANNEX D56 – ABR98 & ABRL98.....	309
ANNEX D57 – AB105/513.....	311
ANNEX D58 – ABR255.....	313
ANNEX D59 – ABD45100 & ABDW45100.....	319
ANNEX D60 – ADR6090L.....	322
ANNEX D61 – ABTR120/180/240.....	325
ANNEX D62 – ACW155.....	329
ANNEX D63 – AE90-RW.....	333

Translations of this European Technical Assessment in other languages shall fully correspond to the original issued document and should be identified as such.

Communication of this European Technical Assessment, including transmission by electronic means, shall be in full (excepted the confidential Annex(es) referred to above). However, partial reproduction may be made, with the written consent of the issuing Technical Assessment Body. Any partial reproduction has to be identified as such.

## II SPECIAL CONDITIONS OF THE EUROPEAN TECHNICAL ASSESSMENT

### 1 Technical description of product and intended use

#### Technical description of the product

This ETA covers the following angle bracket types: ABR90, AB90, ABR105, AB105, ABR70, AB70, E20/3, E9/2.5, E9S/2.5, ABR9015, ABR9020, ABR100, AA60280, ABB40390, AE48, AE76, AE116, AG40312, AG40412, AG40314, AG40414, AH9035, AJ60416, AJ80416, AJ99416, ES, LS, TAZ, KNAG, ABR170, ABR220, AB6983, AB36125, BNV33, E5, AT1, E4, E6, E7, E8, E14, E17, E18, E19, ADR6090, ADR6035, ABAI, AG922, ABR10525, ABR7015, ACR, MAXIMUS, AT2, ABR865, ANP, A-bracket, ACFET, ABR98, ABRL98, AB105/513, ABR255, ADD45100, ABDW45100, ADR6090L, ABTR120/180/240, ACW155, AE90-RW.

The angle brackets are one piece, non-welded, timber-to-timber angle brackets/timber to support (concrete, steel) angle brackets. They are connected to the timber elements/support by a range of nails, screws or bolts.

The Angle Brackets are made from pre-galvanized steel Grade S250GD + Z275 according to EN 10346 with tolerances according to EN 10143 except if another material is stated. Material, dimensions and nail positions are shown in Annex D and typical installations are shown in Annex B.

All the angle brackets can also be produced from stainless steel number 1.4401, 1.4404, 1.4521, 1.4301 or 1.4509 according to EN 10088-2 or a stainless steel with a minimum characteristic 0.2% yield stress of 240 MPa, a minimum 1.0% yield stress of 270 MPa and a minimum ultimate tensile strength of 530 MPa.

In the rest of this document, the steel types will be named as:

Steel ref. 1: S250GD + Z275

Steel ref. 2: Stainless Steel 1.4401, 1.4404, 1.4521

Steel ref. 3: Stainless Steel 1.4301, 1.4509

Steel ref. 4: SS Grade 33 + G90 (~Z275) or G185 (~Z600)

### 2 Specification of the intended use in accordance with the applicable EAD

The angle brackets are intended for use in making connections in load bearing structures, as a connection between two timber beams or a timber

beam and a timber post or between a timber member and a concrete/steel member, where requirements for mechanical resistance and stability and safety in use in the sense of the Basic Works Requirements 1 and 4 of Regulation (EU) 305/2011 shall be fulfilled.

The connection may be with a single angle bracket or with an angle bracket on each side of the fastened timber member.

The static and kinematic behaviour of the timber members or the supports shall be as described in Annex C.

The wood members can be of solid timber, glued laminated timber and similar glued members, or wood-based structural members with a characteristic density from 290 kg/m<sup>3</sup> to 420 kg/m<sup>3</sup>.

This requirement to the material of the wood members can be fulfilled by using the following materials:

- Solid timber classified to C14-C40 according to EN 338 / EN 14081
- Glued members of timber classified to C14-C40 according to EN 338 / EN 14081 when structural adhesives are used.
- Glued laminated timber classified to GL24c or better according to EN 1194 / EN 14080.
- Solid Wood Panels, SWP according to EN 13353.
- Laminated Veneer Lumber LVL according to EN 14374
- Laminated Strand Lumber, e.g. Parallam and Timber Strand
- Plywood according to EN 636
- Oriented Strand Board, OSB according to EN 300
- Cross Laminated Timber (CLT) acc. to EN 16351 or ETA

Annex D states the load-carrying capacities of the Angle Bracket connections for a characteristic density of 350 kg/m<sup>3</sup>.

For timber or wood-based material with a lower characteristic density than 350 kg/m<sup>3</sup> the load-carrying capacities shall be reduced by the  $k_{dens}$  factor (see Annex C4-2)

The design of the connections shall be in accordance with Eurocode 5 or a similar national Timber Code. The wood members shall have a thickness, which is larger than the penetration depth of the nails into the members

The angle brackets may also be used for connections between a timber member and a member of concrete, steel or masonry.

The angle brackets are primarily for use in timber structures subject to the dry, internal conditions defined by service class 1 and 2 of Eurocode 5 and for connections subject to static or quasi-static loading.

The angle brackets can also be used in outdoor timber structures, service class 3, when a corrosion protection in accordance with Euro Code 5 is applied, or when stainless steel with similar or better characteristic yield and ultimate strength is employed.

The scope of the hangers regarding resistance to corrosion shall be defined according to national provisions that apply at the installation site considering environmental conditions and in conjunction with the admissible service conditions according to EN 1995-1-1 and the admissible corrosivity category as described and defined in EN ISO 12944-2

The provisions made in this European Technical Assessment are based on an assumed intended working life of the angle brackets of 50 years.

The indications given on the working life cannot be interpreted as a guarantee given by the producer or Assessment Body, but are to be regarded only as a means for choosing the right products in relation to the expected economically reasonable working life of the works.

### 3 Characteristics of product and assessment

Characteristic	Assessment of characteristic
<b>3.1 Mechanical resistance and stability*) (BWR1)</b>	
Characteristic load-carrying capacity	See Annex D
Stiffness	No performance determined
Ductility in cyclic testing	No performance determined
<b>3.2 Safety in case of fire (BWR2)</b>	
Reaction to fire	The angle brackets are made from steel classified as <b>Euroclass A1</b> in accordance with EN 13501-1 and EC decision 96/603/EC, amended by EC Decision 2000/605/EC
<b>3.3 Hygiene, health and the environment (BWR3)</b>	
Influence on air quality	The product does not contain/release dangerous substances specified in TR 034, dated March 2012
<b>3.7 Sustainable use of natural resources (BWR7)</b>	Not relevant
<b>3.8 General aspects related to the performance of the product</b>	The angle brackets have been assessed as having satisfactory durability and serviceability when used in timber structures using the timber species described in Eurocode 5 and subject to the dry internal conditions defined by service class 1, 2 and 3
<b>Identification</b>	See Annex D

\*) See additional information in section 3.9 – 3.12.

### 3.9 Methods of verification

#### Safety principles and partial factors

The characteristic load-carrying capacities have been calculated considering different ratios between the partial factors for timber connections and steel cross sections.

According to clause 6.3.5 of EN 1990 (Eurocode – Basis of structural design) the characteristic resistance for structural members that comprise more than one material acting in association should be calculated as

$$R_d = \frac{1}{\gamma_{M,1}} R \left\{ \eta_1 X_{k,1}; \eta_i X_{k,i(i>1)} \frac{\gamma_{m,1}}{\gamma_{m,i}}; a_d \right\}$$

where  $\gamma_{M,1}$  is the global partial factor for material 1 (in this case wood),  $\gamma_{m,1}$  is the partial factor on the material and  $\gamma_{m,i}$  are material partial factors for the other materials, i.e. the calculations are made with material parameters modified by multiplication by

$$k_{modi} = \gamma_{m,1} / \gamma_{m,i}$$

The characteristic load-carrying capacities have been calculated considering a ratio between the partial factor for timber connections and steel cross sections

$$k_{modi} = 1,18 \quad (EC5: k_{modi} = \frac{1,30}{1,10} = 1,18)$$

For  $k_{modi} > 1,18$  the load-carrying capacities stated in Annex D are valid (on the safe side).

For  $k_{modi} < 1,18$  the load-carrying capacities stated in Annex D have to be multiplied by a factor

$$f = \frac{k_{modi}}{1,18}$$

#### 3.10 Mechanical resistance and stability

See annex D for characteristic load-carrying capacity in the different directions  $F_1$  to  $F_5$ .

The characteristic capacities of the angle brackets are determined by calculation assisted by testing as described in the EOTA Guideline 015 clause 5.1.2. They should be used for designs in accordance with Eurocode 5 or a similar national Timber Code.

No performance has been determined in relation to ductility of a joint under cyclic testing. The contribution to the performance of structures in seismic zones, therefore, has not been assessed.

For some Angle Brackets, the performance has been determined in relation to the joint's stiffness properties - to be used for the analysis of the serviceability limit state.

#### Fasteners

The load bearing capacities of the brackets have been determined based on the use of Connector nails CNA or connector screws CSA in accordance with ETA-04/0013.

It is allowed to use other connector nails or connector screws in accordance with the standard EN 14592 with the same or better performance than the used 4,0 mm CNA Connector nails and still achieve the same load-bearing capacity of the connection.

For some brackets the load bearing capacities have been determined based on the use of bolts or powder actuated pins or wood screws – see Annex C3 for complete list.

For any other information about fasteners or characteristic capacity modification method for different fasteners, please see Annex C4-1.

The angle brackets can be mounted using different nail/screw patterns. The nail/screw patterns for each angle bracket and different connection type is described and shown in annex D.

#### Stainless steel

All the Angle Brackets can also be produced from stainless steel number 1.4401, 1.4404, 1.4521 (Steel ref. 2) and 1.4301, 1.4509 (Steel ref. 3) according to EN 10088-2 or a stainless steel with a minimum characteristic 0.2% yield stress of 240 MPa, a minimum 1.0% yield stress of 270 MPa and a minimum ultimate tensile strength of 530 MPa. The characteristic load carrying capacities can be considered as the same as those published in this document subject to the use of stainless CNA connector nails or CSA connector screws covered by the ETA-04/0013 or stainless threaded nails or screws in accordance to the standard EN 14592 respecting the rules given in the paragraph "fasteners" above.

#### 3.11 Aspects related to the performance of the product

##### 3.11.1 Corrosion protection in service class 1 and 2.

In accordance with ETAG 015 shall the angle bracket have a zinc coating weight of Z275. The steel employed is S250 GD with Z275 (Steel ref. 1



or 4) according to EN 10346.

### 3.11.2 Corrosion protection in service class 3.

In accordance with Eurocode 5 the Angle Brackets shall be produced from stainless steel (Steel ref. 2 or 3).

### **3.12 General aspects related to the use of the product**

Simpson Strong-Tie angle brackets types ABR90, AB90, ABR105, AB105, ABR70, AB70, E20/3, E9/2.5, E9S/2.5, ABR9015, ABR9020, ABR100, AA60280, ABB40390, AE48, AE76, AE116, AG40312, AG40412, AG40314, AG40414, AH9035, AJ60416, AJ80416, AJ99416, ES, LS, TAZ, KNAG, ABR170, ABR220, AB6983, AB36125, BNV33, E5, AT1, E4, E6, E7, E8, E14, E17, E18, E19, ADR6090, ADR6035, ABAI, AG922, ABR10525, ABR7015, ACR, MAXIMUS, AT2, ABR865, ANP, A-bracket, ACFET, ABRL98, AB105/513, ABR255, ADD45100, ABDW45100, ADR6090L, ABTR120/180/240, ACW155, AE90-RW, are manufactured in accordance with the provisions of this European Technical Assessment using the manufacturing processes as identified in the inspection of the plant by the notified inspection body and laid down in the technical documentation.

## **4 Assessment and verification of constancy of performance (AVCP)**

### **4.1 AVCP system**

According to the decision 97/638/EC of the European Commission<sup>1</sup>, as amended, the system(s) of assessment and verification of constancy of performance (see Annex V to Regulation (EU) No 305/2011) is 2+.

## **5 Technical details necessary for the implementation of the AVCP system, as foreseen in the applicable EAD**

Technical details necessary for the implementation of the AVCP system are laid down in the control plan deposited at ETA-Danmark prior to CE marking.

Issued in Copenhagen on 2017-05-24 by

Thomas Bruun  
Managing Director, ETA-Danmark

## Annex A - Revision History

<b>Modifications and additions to the previous ETA-06/0106 valid from 2016-12-16</b>	
Page	Update
All	Revision of layout, 2D drawings exchanged into 3D (simplified models). Minor typing errors corrected. Steel ref. 1-4 introduced (page 5 and Annex D). No load carrying capacities are changed.
84	D10 ABR9015: Addition of value for ABR9015 fire shot on concrete
333	D63 Addition of AE90-RW

<b>Modifications and additions to the previous ETA-06/0106 valid from 2014-10-14</b>	
Page	Update
1	Changing Manufacturing plant
5	II 2: Addition of CLT
15-16	Annex B: Addition of ACFET200, ABTR, ACW155
23	Annex C4-1: Clarification of how to interpolate
77	D8 E9/2,5: Oblong hole changed into 34,0 instead of 33,5
83	D9 E9S/2,5: Oblong hole changed into 34,0 instead of 33,5
90-91	D10 ABR9015: Values with Screws updated.
95-100	D11 ABR9020: Values with Screws updated. Addition of slip modulus
102-106	D12 ABR100: Values with Screws updated. Addition of slip modulus
114-	D15 AE48: New capacities and add. of nail pattern
120-	D16 AE76: New capacities and add of nail pattern
126	D17 AE116: Modification of capacities (add. of one nail pattern) and addition of slip modulus
168	D27 ABR170/220: No of nails in table D27-3 is corrected (typing error)
191-	D33 AT1: Values for (new) Table 33-4 updated
249	D44 ADR6035: CNA changed into Bolt (typing error)
253-255	D46 AG922: Addition of slip modulus
296-297	D56 ABR98: Addition of ABRL98 and addition of values
300	D58 Addition of ABR255
306	D59 Addition of ABD45100 & ABDW45100
309	D60 Addition of ADR6090L
312	D61 Addition of ABTR
317	D62 Addition of ACW155

<b>Modifications and additions to the previous ETA-06/0106 valid from 2013-05-28 to 2018-05-28</b>	
Pages	Update
	Adjustment from “approval” to “assessment”
	Annex C: added the description for using of one angle bracket
	Annex C4: added the possibility for interpolation by interim values
22ff	D1, D2, D3, D4: ABR90, AB90, ABR105, AB105 added capacities for connection to rigid support
52	Table D4-2: AB105 correction e to f , by $R_{1,k}$ for maximum nailing
97	D11: ABR9020, added values for beam-column
101ff	D12: ABR100, added values for nails 4,0x35, added minimum nailing
111ff	Figure D15-3, D16-3, D17-3, Type AE...: washer for force direction F2/3
129ff	D18: modified the values R2/3 for AG40312 and AG40412
148	D24: ES11: modified the drawing for size 40 to 80 and 100 to 200
159ff	D27, ABR170/220: connections/ values also valid for column to beam/rigid support, added values for $B < 60\text{mm}$
164ff	D28, D29, D30: AB6983, AB36125, BNV33, correction of $k_{\text{mod}}$ in the formulas, insert as “/ $k_{\text{mod}}$ ” for –values determine by the bolt
249	D47: ABR10525, material S350GD instead of S550DG (typing error)
253	D47: ABR10525 added values for beam-column
272	D51: AT2, long hole modified to 9x17mm (before with 8x16mm)
278ff	D-52 to D57: added ABR865, ACFET200 / ACFET200PP, ANP, A-brackets, ABR98, AB105/513
diverse	Annex: D-7, D-18, D-19, D-31 to D-44, D-51: Addition of bolt-factors

<b>Modifications and additions to the previous ETA-06/0106 valid from 2012-09-07 to 2016-10-13</b>	
Pages	Update
85+88+90	Table D11-3 + D11-5 minimum nailing of ABR9020
86+90	New table D11-6 ABR9020 fastening on steel with PAT pins
242+244	New table D47-3 ABR10525 fastening on steel with PAT pins
91+97	New table D12-7 ABR100 fastening on steel with PAT pins
254+255	Table D49-1 + D49-2 ACR7015/ACR9020/ACR10525 – other load directions
88+243+246+255	$R_{1,k}$ for connections with 2 angle brackets have been changed from calculated values to values based on tests for ABR9020, ABR10525, ABR7015 and ACR

<b>Modifications and additions to the previous ETA-06/0106 valid from 2011-10-13 to 2016-10-13</b>	
Pages	Update
	Table headings updated with “modified characteristic capacities” and old table no. deleted
86+87	Revision of capacity table D11-3 and D11-4 for ABR9020
230	Change measurement B on figure D44-1, ADR6035
237	Addition of ABR10525
241	Addition of ABR7015
244	Addition of ACR
250	Addition of MAXIMUS
254	Addition of AT2

<b>Modifications and additions to the previous ETA-06/0106 valid from 2011-05-25 to 2014-08-12</b>	
Pages	Update
	Merging of ETA-06/0106 + ETA-07/0055 + ETA-07/0194
25	Update of table D1-1 - 2 angle brackets ABR90
27	Update of Ø4.0x40 capacities in table D1-4 for ABR90 for minimum nailing
34	Update of table D2-1 - 2 angle brackets AB90
49	Update of table D4-1 - 2 angle brackets AB105
95	Update of table D12-3 – 2 angle brackets ABR100 with addition of $R_{4/5,k}$ capacities
96	Update of table D12-4 – 1 angle bracket ABR100 with addition of $R_{4,k}$ and $R_{5,k}$ capacities
156	Addition of $F_k$ capacities for ABR170 and ABR220 for timber to concrete connection (table D28-2)
162 - 229	Revision of capacity tables according to ETA-04/0013 for annex D32 to D43
230	Update of capacity tables D44-2 for ADR6090 $R_{1,k}$ for concrete structure
234	Addition of ABA1105
236	Addition of AG922

<b>Modifications and additions to the previous ETA-06/0106 valid from 2009-08-12 to 2014-08-12</b>	
Pages	Update
87	ABR100 nail for use in concrete have been added

<b>Modifications and additions to the previous ETA-06/0106 valid from 2008-10-27 to 2013-10-27</b>	
Pages	Update
6,9	Add of the possible production of the brackets in stainless steel.
13	4.0x35 and 4.2x35 connector nails have been added.
13,16	Angle bracket ABR100 have been added
27	ABR100 nail pattern have been added.
28	The formulas for combined forces have been revised.
75, 76, 79, 80	$F_4$ and $F_5$ have been added for ABR9015 and ABR9020 for screws
77, 78, 81, 82	$F_1$ , $F_2/F_3$ have been added for ABR9015 and ABR9020 for nails
83, 84, 85, 86	$F_1$ , $F_2/F_3$ have been added for ABR100 for nails and screws (1 and 2 brackets)

<b>Modifications and additions to the previous ETA-06/0106 valid from 2007-08-22 to 2012-08-22</b>	
Pages	Update
6	The formula for $k_{dens}$ has been changed from the power of 2 to the power of 1
16, 27, 75, 76	Angle Bracket 9015 has been added
16, 27, 77, 78	Angle Bracket 9020 has been added
32-74	Revision of capacity tables according to ETA-04/0013

## Annex B - Typical Installation

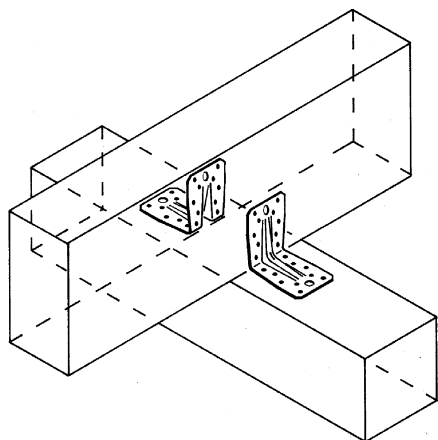

FIGURE B1 - BEAM TO BEAM CONNECTION

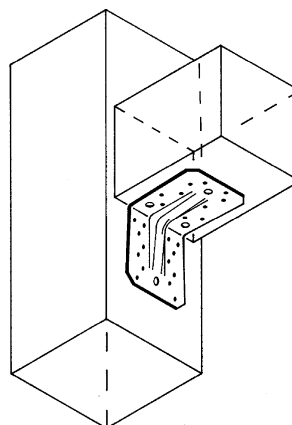

FIGURE B2 - BEAM TO COLUMN CONNECTION

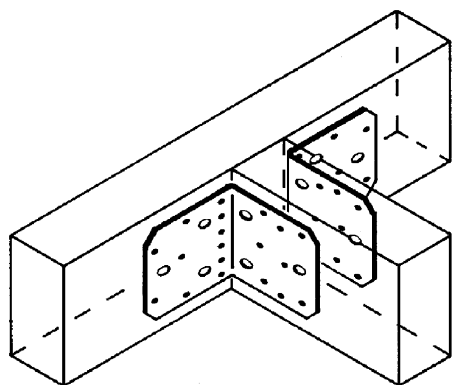
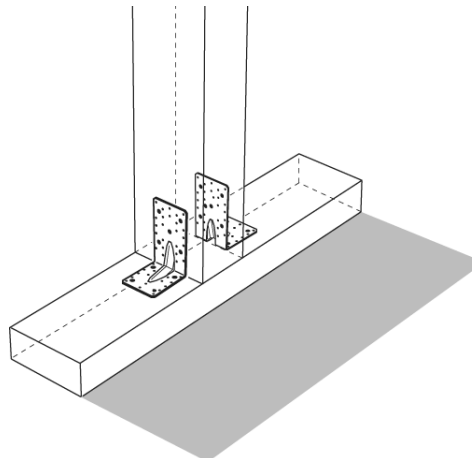

FIGURE B3 - TRIMMER CONNECTION



FIGURER B4 - POST TO BEAM CONNECTION

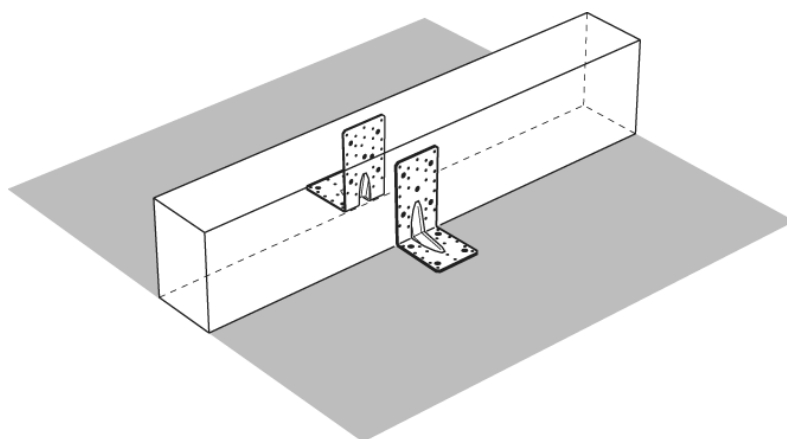

FIGURE B5 - BEAM TO RIGID SUPPORT WITH BOLTS

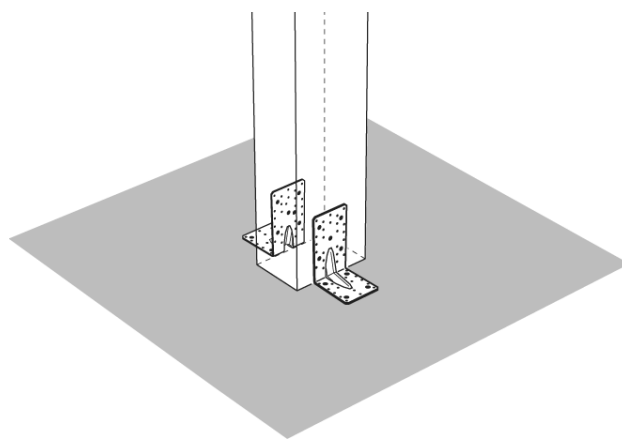
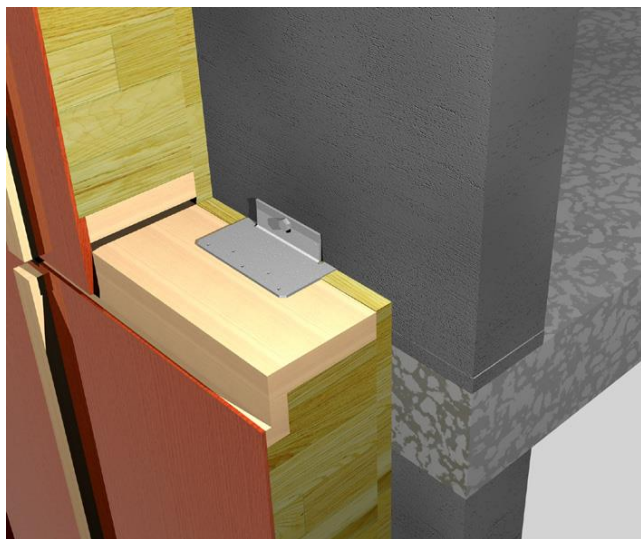
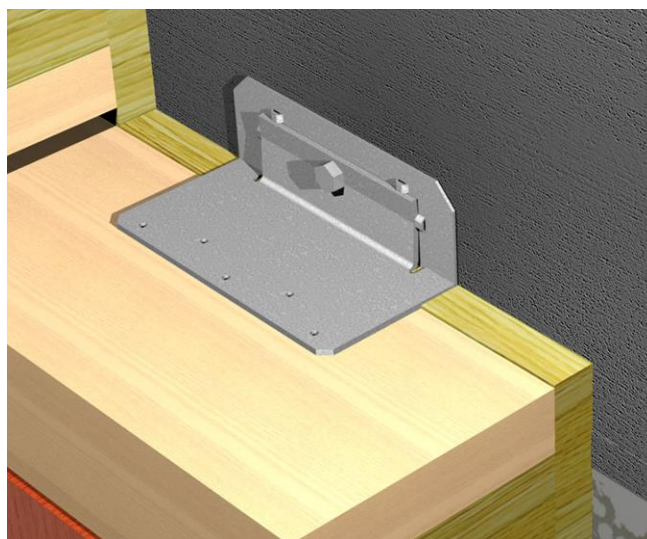

FIGURE B6 - POST TO RIGID SUPPORT WITH BOLTS

**Typical installation of ACFET200 & ACFET200PP:**



ACFET200 attached on a concrete wall



ACFET200PP attached on a Lightweight Aggregate Concrete (LAC) wall

**Typical installation of ABTR:**

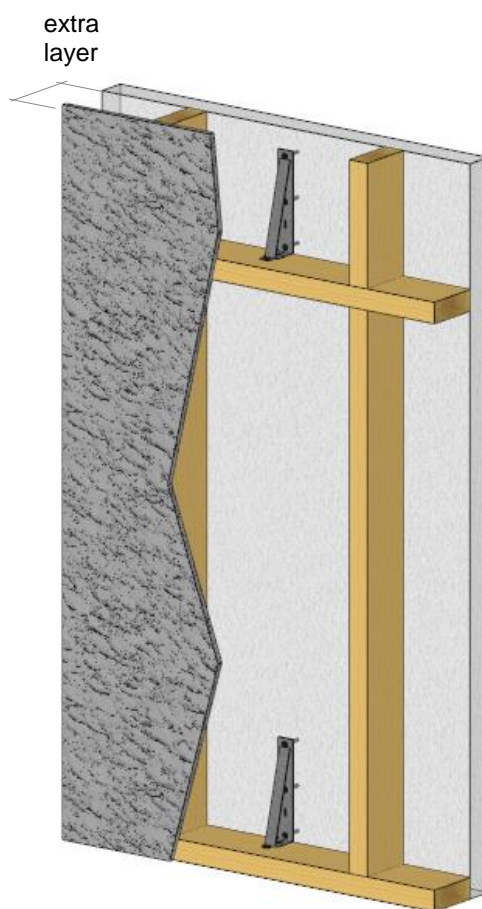

**Typical installation of ACW155:**

- **on front of concrete floor:**

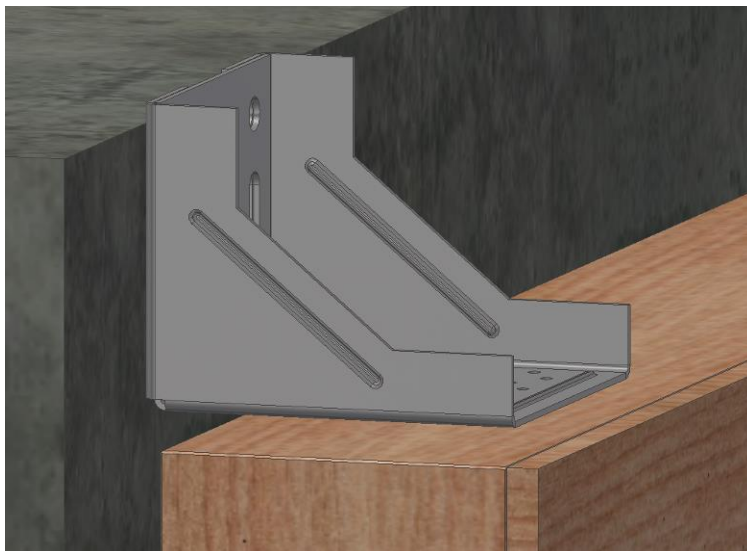
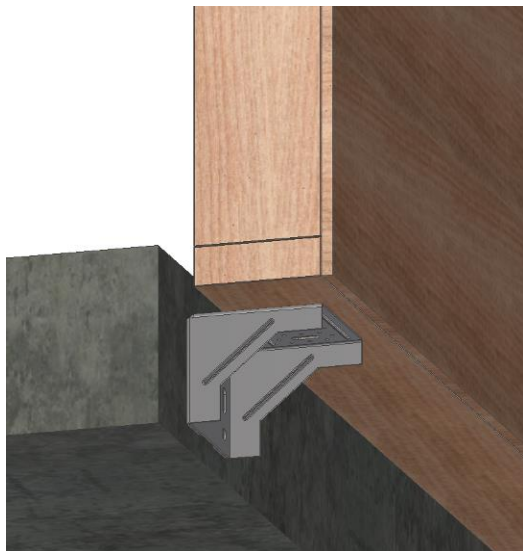

- **on top of concrete floor:**





**Typical installation of AE90-RW:**

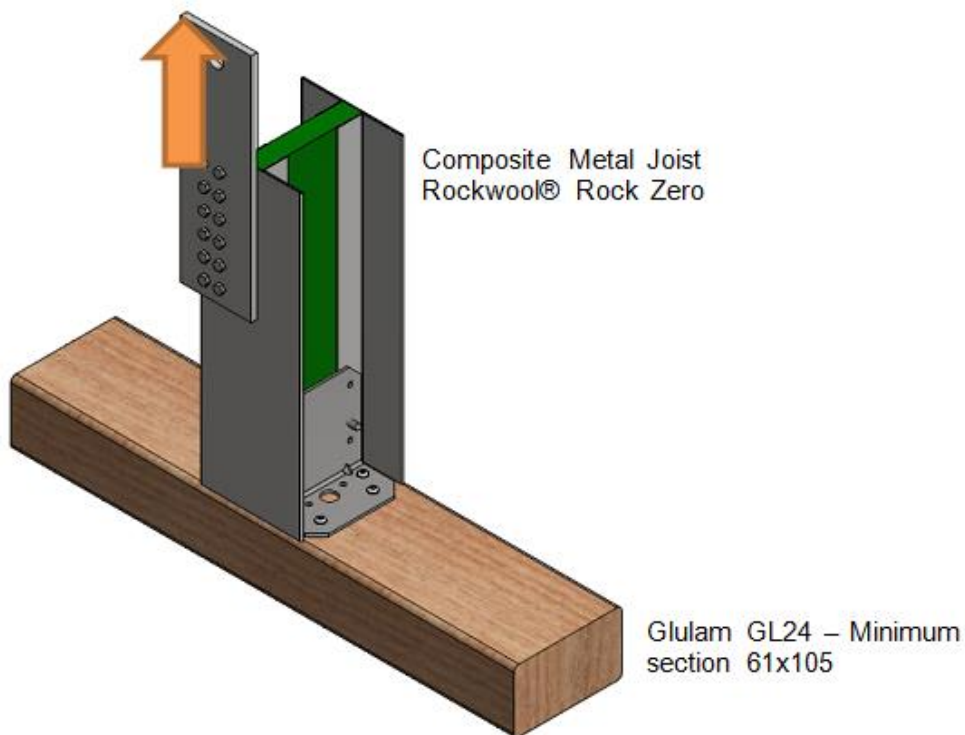

**Typical installation of ABR9015 fire shot on concrete:**

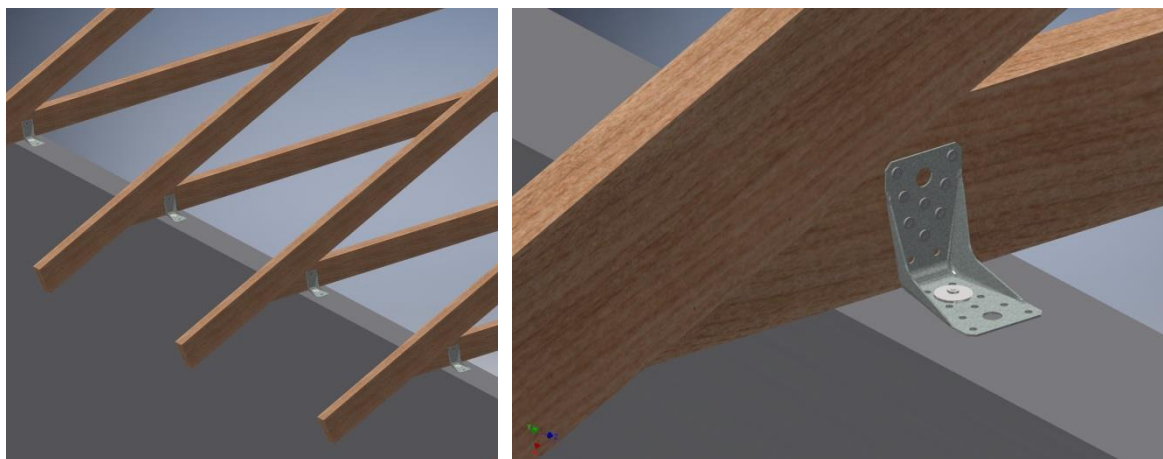

Above are shown all the typical installation. Any other particular installation is described in the Annex D for the specific product.

## Annex C - Basis of design

### Annex C1 – Basis of Design

All the general basis of design are given here. These rules applied to all products listed in this ETA except if something else is stated in Annex D for a particular product.

Most of the capacities stated in the Annex D tables are **modified characteristic capacities** " $R_{i,k} \times k_{mod}$ ". It means that the capacity given for a specific load duration category (P, L, M, S or I) already takes into account the  $k_{mod}$  factor. The design capacities are obtained according to the following formula.

$$R_d = \frac{R_k \times k_{mod}}{\gamma_M}$$

Some of the capacities stated in the Annex D tables are **characteristic capacities**  $R_k$ . Therefore, the design capacities are obtained according to the following formula:

$$R_d = \frac{R_k \times k_{mod}}{\gamma_M}$$

#### Combined forces

For practical purposes, the strength verification is always carried out for design forces and design capacities.

For all Angle Brackets included in this ETA, the following inequalities shall be fulfilled:

$F_1$  combined with  $F_2$  or  $F_3$ :

$$\left( \frac{F_{1,d}}{R_{1,d}} \right)^2 + \left( \frac{F_{2or3,d}}{R_{2or3,d}} \right)^2 \leq 1$$

$F_1$  combined with  $F_4$  or  $F_5$ :

$$\frac{F_{1,d}}{R_{1,d}} + \frac{F_{4or5,d}}{R_{4or5,d}} \leq 1$$

$F_1$  combined with  $F_2$  or  $F_3$  and  $F_4$  or  $F_5$ :

$$\sqrt{\left[ \frac{F_{1,d}}{R_{1,d}} + \frac{F_{4or5,d}}{R_{4or5,d}} \right]^2 + \left[ \frac{F_{2or3,d}}{R_{2or3,d}} \right]^2} \leq 1,0$$

#### Timber splitting

For forces acting perpendicular to the grain in the timber it must be checked that splitting will not occur in accordance with Eurocode 5 or a similar national Timber Code.

## Annex C2 – Definition of forces direction

### C2-1: Forces - Beam to beam connection, beam to support with bolts

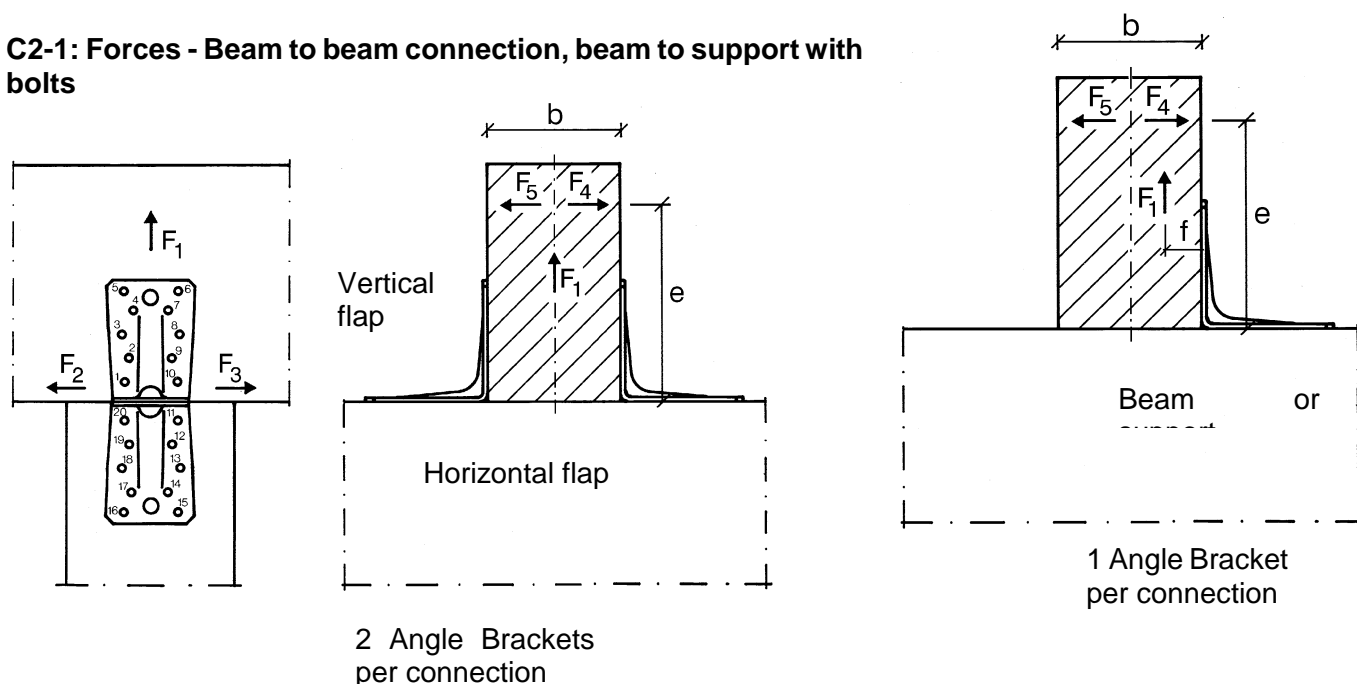

Figure C2-1: Beam to beam connection, beam to support with bolts

#### 2 angle brackets per connection

The Angle Brackets must be placed at each side opposite to each other.

#### Acting forces

- $F_1$  Lifting force acting along the central axis of the joint.
- $F_2$  and  $F_3$  Lateral force acting in the joint between the purlin and beam in the purlin direction.
- $F_4$  and  $F_5$  Lateral force acting in the beam direction along the central axis of the joint but elevated  $e$  above the beam.

#### 1 angle bracket per connection

##### Acting forces

- $F_1$  Lifting force acting in the central axis of the angle bracket but in a distance  $f$  from the vertical flap of the angle bracket.  
If the purlin is prevented from rotation the load-carrying capacity will be half that of a connection with 2 angle brackets.
- $F_2$  and  $F_3$  Lateral force acting in the joint between the purlin and the beam in the purlin direction, the purlin have to be prevented from twisting.
- $F_4$  Lateral force acting in the beam direction perpendicular to the vertical flap elevated  $e$  above the beam directed towards the angle brackets vertical flap.
- $F_5$  Lateral force acting in the beam direction perpendicular to the vertical flap elevated  $e$  above the beam directed away from the angle brackets vertical flap.

#### Wane on under the flap towards the purlin

For most of the Angle Brackets, wane under the flap towards the purlin is allowed provided it does not occur under the fasteners.

Under each table in Annex D is indicated weather wane is allowed or not allowed.

### C2-2: Forces – Beam to column connection

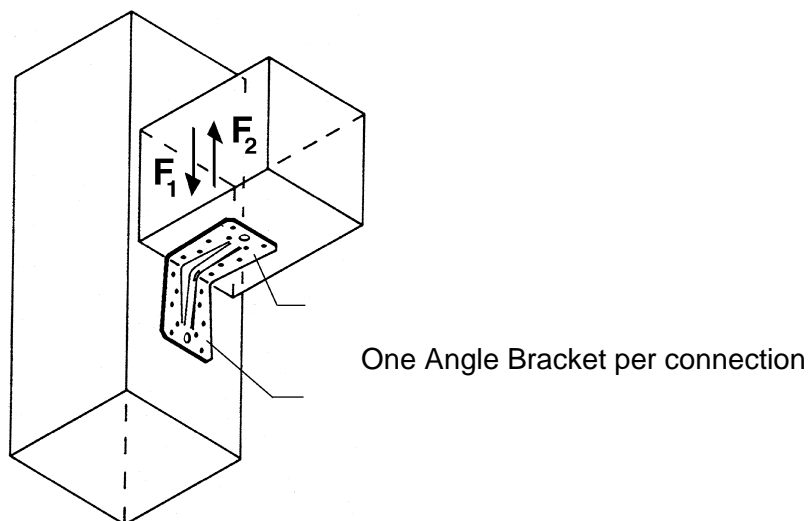
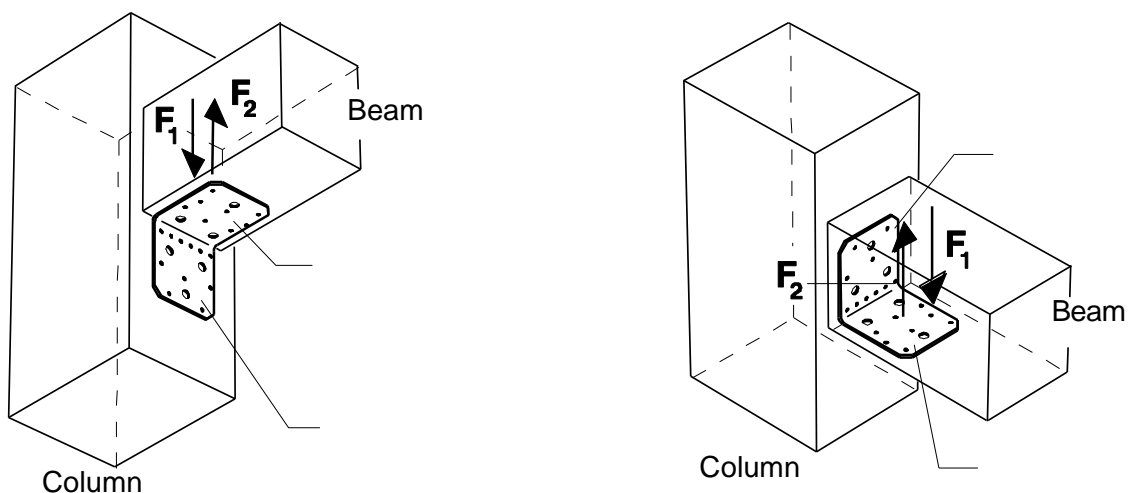

Figure C2-2-1: Beam to column connection – Angle Bracket with a rib



Flap turned downwards

Flap turned upwards

Figure C2-2-2: Beam to column connection – Angle bracket without a rib

*1 angle bracket per connection*

*Acting forces*

$F_1$  Downward force acting along the central axis of the Angle Bracket.

$F_2$  Lifting force acting along the central axis of the Angle Bracket.

### C2-3: Forces – Post to beam connection, post to support with bolts

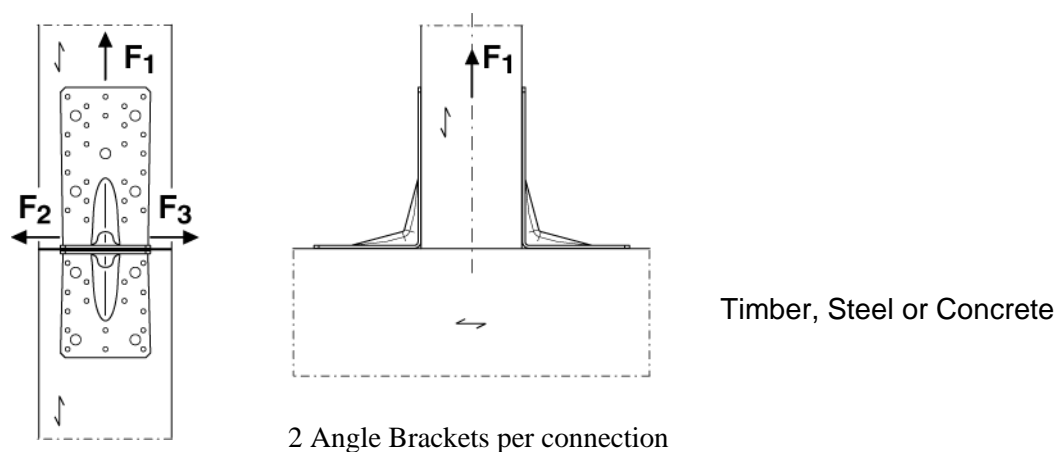

Figure C2-3: Post to beam connection, post to support with bolts

#### 2 angle brackets per connection

The angle brackets must be placed at each side opposite to each other.

#### Acting forces

- $F_1$  Lifting force acting along the central axis of the joint.
- $F_2$  and  $F_3$  Lateral force acting in the joint between the post and the beam parallel to the bend line in the Angle Bracket.

#### 1 angle bracket per connection

The load-carrying capacities will be half of that of a connection with two Angle Brackets per connection, the post have to be prevented from twisting.

#### Wane

The timber shall have plane surfaces under the Angle Bracket, which means that wane may not occur under the angle bracket.

**C2-4: Forces – Trimmer connection**

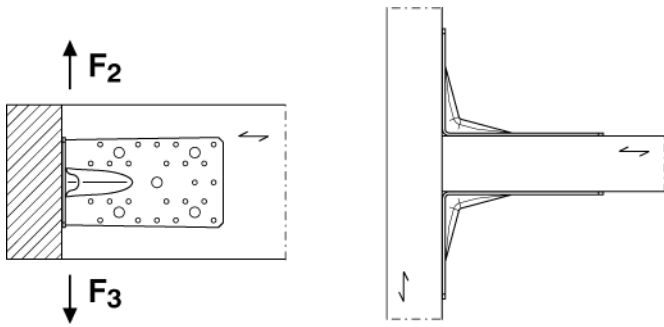

Figure B3: Trimmer connection

**2 angle brackets per connection**

The angle brackets must be placed at each side opposite to each other.

**Acting forces**

$F_2$  and  $F_3$  Lateral force parallel to the bend line in the Angle Bracket in the joint between the joist and the header.

**1 angle bracket per connection**

The load-carrying capacities will be half of that of a connection with 2 angle brackets per connection, the post has to be prevented from twisting.

**Wane**

The timber shall have plane surfaces under the Angle Bracket, which means that wane may not occur under the angle bracket.

**C2-5 : Connection with bolts**

Below the load-tables for connection with bolts are given factors.

It has to be checked, that the bolt has a capacity to absorb the resultant overlapping forces.

$$R_{\text{bolt ax/lat}} \geq \text{factor}_{\text{ax/lat}} \times \text{acting load.}$$

The factor  $k_{\text{lat}}$  is given to determine the shear load for the bolt

The factor  $k_{\text{ax}}$  is given to determine the axial load for the bolt

Each bolt shall have a capacity to sustain a lateral force of:  $\geq k_{\text{lat}} \times F_{i,d}$

Each bolt shall have a capacity to sustain a axial force of:  $\geq k_{\text{ax}} \times F_{i,d}$

Combinations of loads have to be considered.

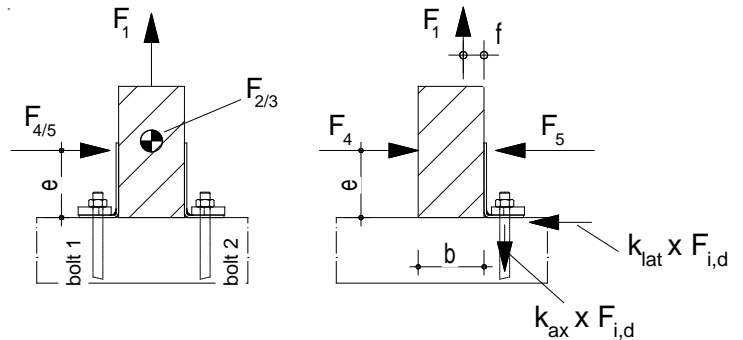

**Annex C3 – Fasteners specification and capacities**

CNA connector nails and CSA connector screws according to ETA-04/0013:

Nail and screw type	Nail and screw size (mm)		Finish
	Diameter	Length	
According to ETA-04/0013 annex A drawing 1 and 2			
Connector nail	3,1	--	Electroplated zinc
Connector nail	3,7	50	Electroplated zinc
Connector nail	4,0	35	Electroplated zinc
Connector nail	4,0	40	Electroplated zinc
Connector nail	4,0	50	Electroplated zinc
Connector nail	4,0	60	Electroplated zinc
Connector screw	5,0	35	Electroplated zinc
Connector screw	5,0	40	Electroplated zinc
Connector screw	5,0	50	Electroplated zinc
Connector nail	4,2	35	Electroplated zinc
Connector nail	4,2	50	Electroplated zinc
Connector nail	4,2	60	Electroplated zinc

Other fasteners:

Nail, screw and bolt type	Nail, screw and bolt size (mm)		Finish
	Diameter	Length	
Threaded nail according to EN 14592	3,1	--	Electroplated zinc
Smooth nail according to EN 14592	3,75	75	Hot-dip galvanized
Threaded nail according to EN 14592	4,0	--	Electroplated zinc
PDPA-75	4,0	19	Electroplated zinc
Wood screw	6,0	45	Electroplated zinc
Wood screw	8,0	120	Electroplated zinc
Wood screw SD25600	6,4	152	Double-barrier coating
Bolt M8	8		For relevant angle brackets see the assumed characteristic capacities of the bolt connection and compare with the specification of the manufacturer
Bolt M10	10		
Bolt M12	12		

## **Annex C4 – Characteristic capacity modification methods for nails and timber types**

### **C4 – 1: Characteristic capacity modification method for different nails**

#### **CNA Connector nails and CSA Connector screws in accordance to ETA-04/0013**

When the load bearing capacity of a bracket have been determined based on the use of Connector nails CNA 4,0x35, CNA4,0x40, CNA4,0x50 or CNA4,0x60 in accordance with ETA-04/0013 it is allowed to use longer 4,0 mm CNA Connector nails or Connector screws CSA5,0x35, CSA5,0x40, CSA 5,0x50 or Connector nails CNA4,2x35, CNA4,2x50, CNA4,2x60 in accordance with ETA-04/0013 with the same or better performance than the used 4,0 mm CNA Connector nails and still achieve the same load-bearing capacity of the connection.

When the load bearing capacity of a bracket have been determined based on the use of Connector screws it is always allowed to use a longer screw and the capacities will still be valid. If shorter Connector screws are used and no calculations are made a reduction factor equal to the ratio between the withdrawal capacity of the short screw and the withdrawal capacity of the long screw is applicable for all loadbearing capacities of the connection.

It is always allowed to interpolate between two sizes of nails or screws. For example the capacity of Connector nails CNA 4,0x50 in accordance with ETA-04/0013 can be calculated as the mean value of the capacity of the connection when Connector nails CNA4,0x40 and CNA4,0x60 are used:

To calculate the capacity with CNA4.0x50, the value of the capacity with CNA4.0x40 must be multiply by a factor  $k$  and must be limited to the value with CNA4.0x60.

For  $F_1$  load direction on timber  $k = R_{ax}CNA4.0x60 / R_{ax}CNA4.0x40$

For  $F_1$  load direction on rigid support  $k = R_{lat}CNA4.0x60 / R_{lat} CNAx4.0x40$

For  $F_2$  and  $F_3$  load direction on all support  $k = R_{lat}CNA4.0x60 / R_{lat}CNAx40$

For  $F_4$  and  $F_5$  load direction on all support  $k = R_{ax}CNA4.0x60 / R_{ax}CNA4.0x40$

#### **Threaded nails in accordance to EN 14592**

For all Angle Brackets the design models also allow the use of threaded nails in accordance to EN 14592 with a diameter in the range 4,0 – 4,2 mm and a minimum length of 35 mm, assuming a thick steel plate when calculating the lateral nail load-bearing capacity. If no calculations are made a reduction factor equal to the ratio between the characteristic withdrawal capacity of the actual used threaded nail and the characteristic withdrawal capacity of the corresponding Connector nail according to table B1 in ETA-04/0013 is applicable for all load bearing capacities of the connection.

#### **Other fasteners**

For some Angle Brackets, the load bearing capacities have been determined for a connection between a timber member and its support to a 6 mm steel member using PDPA-75 nails, which are powder actuated pins. The pins have been fastened through the existing holes in the Angle Brackets.

Some Angle Brackets gives the loadbearing capacity for a connection between a timber member and a 6 mm steel quality S355. For this connection, there is no proportionality for other steel grades or thicknesses.

#### **Stainless steel**

For the Angle Brackets produced from stainless steel number 1.4401, 1.4404, 1.4521 (Steel ref. 2) and 1.4301, 1.4509 (Steel ref. 3) according to EN 10088-2:2005 or a stainless steel with a minimum characteristic 0.2% yield stress of 240 MPa, a minimum 1.0% yield stress of 270 MPa and a minimum ultimate tensile strength of 530 MPa., the characteristic load carrying capacities can be considered as the same as those published in this document subject to the use of stainless CNA connector nails or CSA connector screws covered by the ETA-04/0013 or stainless threaded nails or screws in accordance to the standard EN 14592 respecting the rules given in the paragraph above for nails and screws according to ETA-04/0013 and EN14592.



#### **C4 – 2: Characteristic capacity modification method for different timber types**

Annex D states the load-carrying capacities of the Angle Bracket connections for a characteristic density of 350 kg/m<sup>3</sup>.

For timber or wood-based material with a lower characteristic density than 350 kg/m<sup>3</sup> the load-carrying capacities shall be reduced by the  $k_{dens}$  factor:

$$k_{dens} = \left( \frac{\rho_k}{350} \right) \quad \text{Where } \rho_k \text{ is the characteristic density of the timber in kg/m}^3.$$

For interim value, e.g. distances, it's allowed to determine the values by interpolation if nothing else is named by the current table.

## **Annex D - Product definition and capacities**

## Annex D1 – ABR90

### Product Name:

Product Name	Material reference acc. to clause II-1	Alternative product names
ABR90	Steel ref. 1	UK: E2/2.5/7090, France: E2/2.5/7090, Germany: 90 m/R
ABR90S	Steel ref. 2	France: E2IX
ABR90S2	Steel ref. 3	-

### Connector Size Range:

Model no.	Dimensions [mm]				Holes flange A		Holes flange B	
	A	B	C	Thickness	Ø5	Ø11	Ø5	Ø11
ABR90	90	90	65	2,5	10	1	10	1

### Drawing:

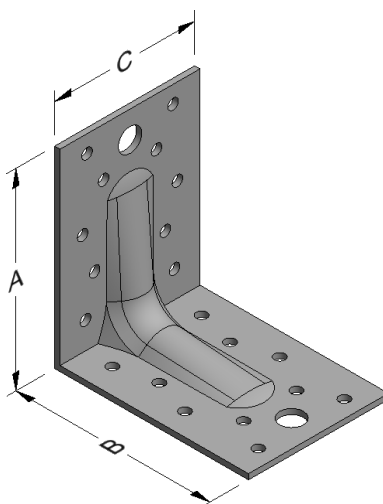

### Nailing pattern:

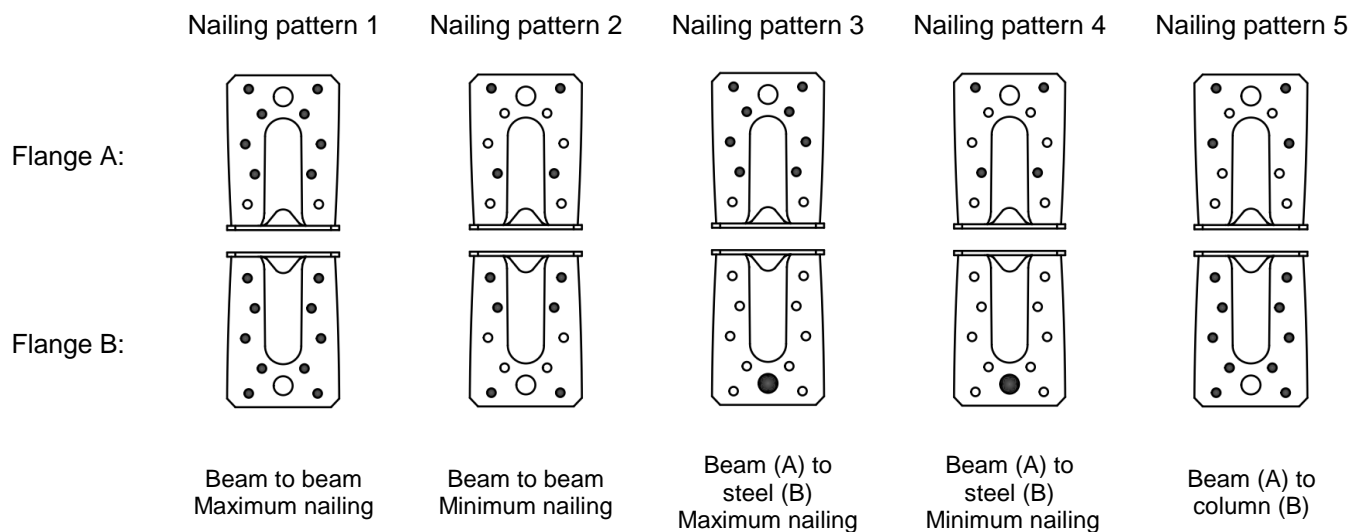

Table D1-1 Modified characteristic capacity timber beam to timber beam – 2 Angle Brackets

2 Angle Brackets ABR90 per connection			Modified characteristic capacity per connection (kN)									
Nailing pattern	Number of fasteners		Load duration	$R_{1,k} \times k_{mod}$		$R_{2/3,k} \times k_{mod}$		$R_{4/5,k} \times k_{mod}$				
	Flange A	Flange B		CNA Connector nail								
				4,0x40	4,0x60	4,0x40	4,0x60	4,0x40	4,0x60			
Nailing pattern 2	4	6	P	3,2	5,3	3,4	4,4	$\frac{6,1 \cdot b + 431}{e - 10,7}$	$\frac{6,84 \cdot b + 430}{e - 10,7}$			
				1,0	2,3					max 5,1	max 7,2	
			L	3,7	6,2	4,0	5,1	$\frac{6,2 \cdot b + 431}{e - 10,7}$	$\frac{7,17 \cdot b + 430}{e - 10,7}$			
				1,3	3,0					max 5,6	max 8,0	
			M	4,3	7,1	4,6	5,9	$\frac{6,4 \cdot b + 431}{e - 10,7}$	$\frac{7,5 \cdot b + 430}{e - 10,7}$			
				1,6	3,7					max 6,1	max 8,9	
			S	4,8	8,0	5,1	6,6	$\frac{6,6 \cdot b + 431}{e - 10,7}$	$\frac{7,83 \cdot b + 429}{e - 10,7}$			
				2,0	4,5					max 6,7	max 9,8	
			I	5,9	9,7	6,3	8,1	$\frac{7,0 \cdot b + 430}{e - 10,7}$	$\frac{8,49 \cdot b + 429}{e - 10,7}$			
				2,7	6,4					max 7,7	max 11,5	
			Nailing pattern 1	8	10	P	4,8	8,0	5,6	7,1	$\frac{6,3 \cdot b + 431}{e - 10,7}$	$\frac{7,2 \cdot b + 430}{e - 10,7}$
							1,4	3,2				
L	5,6	9,3				6,5	8,3	$\frac{6,5 \cdot b + 431}{e - 10,7}$	$\frac{7,59 \cdot b + 429}{e - 10,7}$			
	1,8	4,2								max 8,8	max 13,4	
M	6,4	10,6				7,4	9,5	$\frac{6,7 \cdot b + 430}{e - 10,7}$	$\frac{7,98 \cdot b + 429}{e - 10,7}$			
	2,2	5,3								max 9,7	max 15,0	
S	7,1	12,0				8,3	10,6	$\frac{7,0 \cdot b + 430}{e - 10,7}$	$\frac{8,37 \cdot b + 429}{e - 10,7}$			
	2,7	6,5								max 10,7	max 16,6	
I	8,7	14,6				10,2	13,0	$\frac{7,4 \cdot b + 430}{e - 10,7}$	$\frac{9,15 \cdot b + 428}{e - 10,7}$			
	3,8	9,0								max 12,7	max 19,9	

b and e are in mm.

■ When the purlin has a wane on the side towards the Angle Bracket with an extent from the bottom up to the lower nail the value in the grey square is valid.

Table D1-2 Modified characteristic capacity timber beam to timber beam – 1 Angle Bracket Load duration P

1 Angle Bracket ABR90 per connection			Modified characteristic capacity per connection (kN)								
Nailing pattern	Number of fasteners		Load duration	$R_{1,k} \times k_{mod}$		$R_{2/3,k} \times k_{mod}$		$R_{4,k} \times k_{mod}$		$R_{5,k} \times k_{mod}$	
	Flange A	Flange B		4,0x40	4,0x60	4,0x40	4,0x60	CNA Connector nail		4,0x40	4,0x60
Nailing pattern 2	4	6	P	$f \leq 40$ : $\frac{78}{f+60}$	$f \leq 49$ : $\frac{114}{f+60}$	1,7	2,2	$e < 37,5$ : $\frac{30,6}{37,5-e}$	$e < 37,5$ : $\frac{50,9}{37,5-e}$	$e \leq 58$ : $\frac{31}{68-e}$	$e \leq 55$ : $\frac{52}{68-e}$
								$e \leq 37$ : 2,2	$e \leq 42$ : 2,83	3,3	4,2
				$37 < e \leq 101$ : $\frac{81}{e}$	$42 < e \leq 109$ : $\frac{119,8}{e}$	$58 < e \leq 1,83 \cdot b$ : 3,3	$55 < e \leq 1,62 \cdot b + 3$ : 4,2				
				$f > 40$ : $\frac{31,1}{f}$	$f > 49$ : $\frac{51,7}{f}$			$e > 101$ : $\frac{28,9}{e-65}$	$e > 109$ : $\frac{48}{e-65}$	$e > 1,83 \cdot b$ : $\frac{6,1 \cdot b - 225}{e-68}$	$e > 1,62 \cdot b + 3$ : $\frac{6,84 \cdot b - 271}{e-68}$
Nailing pattern 1	8	10	P	$f \leq 34$ : $\frac{85}{f+60}$	$f \leq 41$ : $\frac{127}{f+60}$	2,8	3,5	$e < 37,5$ : $\frac{37,5}{37,5-e}$	$e < 37,5$ : $\frac{62,7}{37,5-e}$	$e \leq 57$ : $\frac{46,3}{68-e}$	$e \leq 54$ : $\frac{77,5}{68-e}$
								$e \leq 20$ : 4,4	$e \leq 23$ : 5,66	4,3	5,8
				$20 < e \leq 96$ : $\frac{89}{e}$	$23 < e \leq 102$ : $\frac{133,1}{e}$	$57 < e \leq 1,47 \cdot b + 10$ : 4,3	$54 < e \leq 1,23 \cdot b + 15$ : 5,8				
				$f > 34$ : $\frac{30,9}{f}$	$f > 41$ : $\frac{51,7}{f}$			$e > 96$ : $\frac{28,7}{e-65}$	$e > 102$ : $\frac{48}{e-65}$	$e > 1,47 \cdot b + 10$ : $\frac{6,3 \cdot b - 247}{e-68}$	$e > 1,23 \cdot b + 15$ : $\frac{7,2 \cdot b - 308}{e-68}$

b, e and f are in mm.

When the purlin has a wane on the side towards the Angle Bracket with an extent from the bottom up to the lower nail the formula in the grey square shall be checked additionally.

Table D1-3 Modified characteristic capacity timber beam to timber beam – 1 Angle Bracket Load duration L

1 Angle Bracket ABR90 per connection			Modified characteristic capacity per connection (kN)								
Nailing	Number of fasteners		Load duration	$R_{1,k} \times k_{mod}$		$R_{2/3,k} \times k_{mod}$		$R_{4,k} \times k_{mod}$		$R_{5,k} \times k_{mod}$	
	Flange A	Flange B		4,0x40	4,0x60	4,0x40	4,0x60	CNA Connector nail		4,0x40	4,0x60
Nailing pattern 2	4	6	L	$f \leq 43$ : $\frac{87}{f+60}$	$f \leq 52$ : $\frac{130}{f+60}$	2,0	2,6	$e < 37,5$ : $\frac{35,7}{37,5-e}$	$e < 37,5$ : $\frac{59,4}{37,5-e}$	$e \leq 57$ : $\frac{36}{68-e}$	$e \leq 54$ : $\frac{69}{68-e}$
								$e \leq 36$ : 2,6	$e \leq 41$ : 3,3	$57 < e \leq 1,77 \cdot b + 1$ : 3,5	$54 < e \leq 1,51 \cdot b + 5$ : 5,0
				$f > 43$ : $\frac{36,3}{f}$	$f > 52$ : $\frac{60,3}{f}$	3,2	4,1	$36 < e \leq 103$ : $\frac{91}{e}$	$41 < e \leq 111$ : $\frac{135,8}{e}$	$e > 1,77 \cdot b + 1$ : $\frac{6,2 \cdot b - 236}{e - 68}$	$e > 1,51 \cdot b + 5$ : $\frac{7,52 \cdot b - 310}{e - 68}$
								$e > 103$ : $\frac{33,7}{e - 65}$	$e > 111$ : $\frac{56}{e - 65}$	$e > 1,39 \cdot b + 11$ : $\frac{6,5 \cdot b - 262}{e - 68}$	$e > 1,17 \cdot b + 16$ : $\frac{7,59 \cdot b - 333}{e - 68}$
Nailing pattern 1	8	10	L	$f \leq 36$ : $\frac{96}{f+60}$	$f \leq 43$ : $\frac{144}{f+60}$	3,2	4,1	$e < 37,5$ : $\frac{43,7}{37,5-e}$	$e < 37,5$ : $\frac{73,2}{37,5-e}$	$e \leq 56$ : $\frac{54}{68-e}$	$e \leq 54$ : $\frac{90,4}{68-e}$
								$e \leq 19$ : 5,1	$e \leq 23$ : 6,61	$56 < e \leq 1,39 \cdot b + 11$ : 4,7	$54 < e \leq 1,17 \cdot b + 16$ : 6,5
				$f > 36$ : $\frac{36}{f}$	$f > 43$ : $\frac{60,3}{f}$	3,2	4,1	$19 < e \leq 99$ : $\frac{100}{e}$	$23 < e \leq 103$ : $\frac{151,3}{e}$	$e > 1,39 \cdot b + 11$ : $\frac{6,5 \cdot b - 262}{e - 68}$	$e > 1,17 \cdot b + 16$ : $\frac{7,59 \cdot b - 333}{e - 68}$
								$e > 99$ : $\frac{33,4}{e - 65}$	$e > 103$ : $\frac{56}{e - 65}$	$e > 1,39 \cdot b + 11$ : $\frac{6,5 \cdot b - 262}{e - 68}$	$e > 1,17 \cdot b + 16$ : $\frac{7,59 \cdot b - 333}{e - 68}$

b, e and f are in mm.

When the purlin has a wane on the side towards the Angle Bracket with an extent from the bottom up to the lower nail the formula in the grey square shall be checked additionally.

Table D1-4 Modified characteristic capacity timber beam to timber beam – 1 Angle Bracket Load duration M

1 Angle Bracket ABR90 per connection			Modified characteristic capacity per connection (kN)								
Nailing pattern	Number of fasteners		Load duration	$R_{1,k} \times k_{mod}$		$R_{2/3,k} \times k_{mod}$		$R_{4,k} \times k_{mod}$		$R_{5,k} \times k_{mod}$	
	Flange A	Flange B		4,0x40	4,0x60	4,0x40	4,0x60	CNA Connector nail		4,0x40	4,0x60
Nailing pattern 2	4	6	M	$f \leq 45$ : $\frac{96}{f+60}$	$f \leq 55$ : $\frac{145}{f+60}$	2,3	2,9	$e < 37,5$ : $\frac{40,8}{37,5-e}$	$e < 37,5$ : $\frac{67,9}{37,5-e}$	$e \leq 56$ : $\frac{41}{68-e}$	$e \leq 54$ : $\frac{69}{68-e}$
								$e \leq 34$ : 2,9	$e \leq 40$ : 3,78		
				$34 < e \leq 105$ : $\frac{101}{e}$	$40 < e \leq 112$ : $\frac{151,9}{e}$	$e > 1,71 \cdot b + 2$ :	$e > 1,51 \cdot b + 5$ :				
				$f > 45$ : $\frac{41,4}{f}$	$f > 55$ : $\frac{68,9}{f}$			$e > 105$ : $\frac{38,5}{e-65}$	$e > 112$ : $\frac{64}{e-65}$	$\frac{6,4 \cdot b - 248}{e-68}$	$\frac{7,5 \cdot b - 309}{e-68}$
Nailing pattern 1	8	10	M	$f \leq 38$ : $\frac{106}{f+60}$	$f \leq 45$ : $\frac{161}{f+60}$	3,7	4,7	$e < 37,5$ : $\frac{50}{37,5-e}$	$e < 37,5$ : $\frac{83,6}{37,5-e}$	$e \leq 55$ : $\frac{62}{68-e}$	$e \leq 53$ : $\frac{103}{68-e}$
								$e \leq 19$ : 5,9	$e \leq 22$ : 7,55		
				$19 < e \leq 99$ : $\frac{111}{e}$	$22 < e \leq 92$ : $\frac{169,6}{e}$	$e > 1,33 \cdot b + 13$ :	$e > 1,12 \cdot b + 17$ :				
				$f > 38$ : $\frac{41,2}{f}$	$f > 45$ : $\frac{68,9}{f}$			$e > 99$ : $\frac{38,2}{e-65}$	$92 < e \leq 111$ : $\frac{109,5}{e-32,5}$	$\frac{6,7 \cdot b - 277}{e-68}$	$\frac{7,98 \cdot b - 359}{e-68}$
								$e > 111$ : $\frac{64}{e-65}$			

b, e and f are in mm.

■ When the purlin has a wane on the side towards the Angle Bracket with an extent from the bottom up to the lower nail the formula in the grey square shall be checked additionally.

Table D1-5 Modified characteristic capacity timber beam to timber beam – 1 Angle Bracket Load duration S

1 Angle Bracket ABR90 per connection			Modified characteristic capacity per connection (kN)								
Nailing	Number of fasteners		Load duration	$R_{1,k} \times k_{mod}$		$R_{2/3,k} \times k_{mod}$		$R_{4,k} \times k_{mod}$		$R_{5,k} \times k_{mod}$	
	Flange A	Flange B		4,0x40	4,0x60	4,0x40	4,0x60	CNA Connector nail		4,0x40	4,0x60
Nailing pattern 2	4	6	S	$f \leq 45$ : $\frac{106}{f+60}$	$f \leq 57$ : $\frac{160}{f+60}$	2,6	3,3	$e < 37,5$ : $\frac{40,8}{37,5-e}$	$e < 37,5$ : $\frac{76,4}{37,5-e}$	$e \leq 56$ : $\frac{47}{68-e}$	$e \leq 53$ : $\frac{77}{68-e}$
								$e \leq 34$ : 3,3	$e \leq 40$ : 4,25	$56 < e \leq 1,67 \cdot b + 3$ : 4,0	$53 < e \leq 1,46 \cdot b + 6$ : 5,3
				$34 < e \leq 105$ : $\frac{110}{e}$	$40 < e \leq 93$ : $\frac{167,9}{e}$			$93 < e \leq 127$ : $\frac{109,5}{e-32,5}$	$e > 1,67 \cdot b + 3$ : $\frac{6,6 \cdot b - 259}{e-68}$		
				$f > 45$ : $\frac{46,6}{f}$	$f > 57$ : $\frac{77,5}{f}$					$e > 105$ : $\frac{43,3}{e-65}$	$e > 127$ : $\frac{72}{e-65}$
Nailing pattern 1	8	10	S	$f \leq 40$ : $\frac{116}{f+60}$	$f \leq 46$ : $\frac{179}{f+60}$	4,2	5,3	$e < 37,5$ : $\frac{76,1}{37,5-e}$	$e < 37,5$ : $\frac{94,1}{37,5-e}$	$e \leq 55$ : $\frac{69}{68-e}$	$e \leq 53$ : $\frac{116}{68-e}$
								$e \leq 18$ : 6,6	$e \leq 22$ : 8,5	$55 < e \leq 1,28 \cdot b + 14$ : 5,4	$53 < e \leq 1,08 \cdot b + 18$ : 7,8
				$18 < e \leq 101$ : $\frac{122}{e}$	$22 < e \leq 79$ : $\frac{186,5}{e}$			$79 < e \leq 127$ : $\frac{109,5}{e-32,5}$	$e > 1,28 \cdot b + 14$ : $\frac{7,0 \cdot b - 292}{e-68}$		
				$f > 40$ : $\frac{46,3}{f}$	$f > 46$ : $\frac{77,5}{f}$					$e > 101$ : $\frac{43}{e-65}$	$e > 127$ : $\frac{72}{e-65}$

b, e and f are in mm.

■ When the purlin has a wane on the side towards the Angle Bracket with an extent from the bottom up to the lower nail the formula in the grey square shall be checked additionally.



Table D1-6 Modified characteristic capacity timber beam to timber beam – 1 Angle Bracket Load duration I

1 Angle Bracket ABR90 per connection			Modified characteristic capacity per connection (kN)								
Nailing pattern	Number of fasteners		Load duration	$R_{1,k} \times k_{mod}$		$R_{2/3,k} \times k_{mod}$		$R_{4,k} \times k_{mod}$		$R_{5,k} \times k_{mod}$	
	Flange A	Flange B		4,0x40	4,0x60	4,0x40	4,0x60	CNA Connector nail		4,0x40	4,0x60
Nailing pattern 2	4	6	I	$f \leq 51:$ $\frac{124}{f+60}$	$f \leq 60:$ $\frac{190}{f+60}$	3,1	4,0	$e < 37,5:$ $\frac{56,2}{37,5-e}$	$e < 37,5:$ $\frac{93,4}{37,5-e}$	$e \leq 55:$ $\frac{57}{68-e}$	$e \leq 52:$ $\frac{95}{68-e}$
								$e \leq 32: 4,0$	$e \leq 36: 5,19$	$55 < e \leq 1,58 \cdot b + 4:$ 4,4	$52 < e \leq 1,39 \cdot b + 7:$ 6,1
				$32 < e \leq 95:$ $\frac{130}{e}$	$36 < e \leq 79:$ $\frac{186,5}{e}$						
				$f > 51:$ $\frac{57}{f}$	$f > 60:$ $\frac{94,7}{f}$			$95 < e \leq 110:$ $\frac{109}{e-32,5}$	$79 < e \leq 198:$ $\frac{109,5}{e-32,5}$	$e > 1,58 \cdot b + 4:$ $\frac{7,0 \cdot b - 282}{e-68}$	$e > 1,39 \cdot b + 7:$ $\frac{8,49 \cdot b - 366}{e-68}$
Nailing pattern 1	8	10	I	$f \leq 42:$ $\frac{137}{f+60}$	$f \leq 48:$ $\frac{213}{f+60}$	5,1	6,5	$e < 37,5:$ $\frac{68,7}{37,5-e}$	$e < 37,5:$ $\frac{115}{37,5-e}$	$e \leq 54:$ $\frac{85}{68-e}$	$e \leq 52:$ $\frac{142}{68-e}$
								$e \leq 18: 8,1$	$e \leq 18: 10,38$	$54 < e \leq 1,20 \cdot b + 16:$ 6,2	$52 < e \leq 1,01 \cdot b + 20:$ 9,1
				$18 < e \leq 103:$ $\frac{144}{e}$	$18 < e \leq 79:$ $\frac{186,5}{e}$						
				$f > 42:$ $\frac{56,6}{f}$	$f > 48:$ $\frac{94,7}{f}$			$e > 103:$ $\frac{52,6}{e-65}$	$79 < e \leq 200:$ $\frac{109,5}{e-32,5}$	$e > 1,20 \cdot b + 16:$ $\frac{7,4 \cdot b - 322}{e-68}$	$e > 1,01 \cdot b + 20:$ $\frac{9,15 \cdot b - 435}{e-68}$
								$e > 200:$ $\frac{87,9}{e-65}$			

b, e and f are in mm.

When the purlin has a wane on the side towards the Angle Bracket with an extent from the bottom up to the lower nail the formula in the grey square shall be checked additionally.

**Table D1-7 Modified characteristic capacity timber beam to timber column – 1 Angle Bracket**

1 Angle Bracket ABR90 per connection				Modified characteristic capacities (kN) - timber to timber			
				R <sub>1,k</sub> x k <sub>mod</sub>		R <sub>2,k</sub> x k <sub>mod</sub>	
Nailing pattern	Number of fasteners		Load duration	CNA 4,0x40	CNA 4,0x60	CNA 4,0x40	CNA 4,0x60
	Flange A (beam)	Flange B (column)					
Nailing pattern 5	4	10	P	5,4	6,6	0,9	1,5
			L	6,3	7,7	1,0	1,7
			M	7,2	8,8	1,2	2,0
			S	8,1	9,9	1,3	2,2
			I	9,9	12,1	1,6	2,7

End gab: max. 5 mm

**Table D1-8 Characteristic capacity timber beam to rigid support – 2 Angle Brackets**

2 Angle Brackets ABR90 per connection			Characteristic capacities per connection (kN)								
			R <sub>1,k</sub>				R <sub>2/3,k</sub>				R <sub>4/5,k</sub>
Nailing pattern	Number of fasteners		CNA connector nails				CNA connector nails				4,0x35 to 4,0x60
	Flange A	Flange B	4,0x35	4,0x40	4,0x50	4,0x60	4,0x35	4,0x40	4,0x50	4,0x60	
Nailing pattern 3	8	1 Bolt	min of:				1,64	1,96	2,6	3,2	max $\left\{ \begin{array}{l} R_4^{1)} + R_5^{1)} \\ \min \left\{ \frac{2,17}{k_{mod}}; \frac{R_1}{2} \times \frac{b}{e} \right\} \end{array} \right.$
			3,1	3,7	4,94	6,14					
Nailing pattern 4	4	1 Bolt	0,74	0,9	1,2	1,48	0,13	0,16	0,22	0,27	1) see table D1-9

Connection with bolt

2 Angle Bracket ABR90 per connection				
factor for:	F <sub>1</sub>	F <sub>2/3</sub>	F <sub>4/5,bolt1</sub>	F <sub>4/5,bolt2</sub>
k <sub>ax</sub>	0,50	-	0,50	0,10
k <sub>lat</sub>	-	0,5	-	1,00

For each bolt it's needed to check: R<sub>bolt,d,lateral</sub> ≥ k<sub>lat</sub> x F<sub>i,d</sub>; R<sub>bolt,d,axial</sub> ≥ k<sub>ax</sub> x F<sub>i,d</sub>; and also the combination.

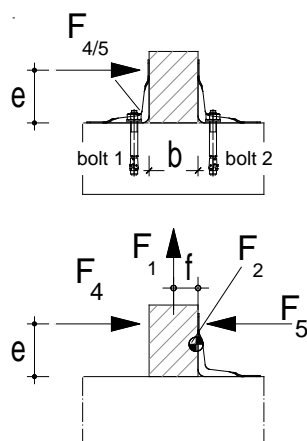

Table D1-9 Characteristic capacity timber beam to rigid support – 1 Angle Bracket

1 Angle Bracket ABR90 per connection			Characteristic capacities per connection (kN)						
			R <sub>1,k</sub>		R <sub>4,k</sub>	R <sub>2/3,k</sub>		R <sub>5,k</sub>	
Nailing pattern	Number of fasteners		4,0x35 to 4,0x60	4,0x35 to 4,0x60	CNA connector nails 4,0x35 to 4,0x60	4,0x35	4,0x40	4,0x50	4,0x60
	Flange A	Flange B							
Nailing pattern 3	8	1 Bolt	21,7 / ((f+16) x k <sub>mod</sub> )	21,7 / (e x k <sub>mod</sub> )	Half of the values for a connection with 2 ABR90, if the timber is prevented from rotation, otherwise R <sub>2/3</sub> =0,0kN	X1=			
						222	266	355	443
						X2=			
Nailing pattern 4	4	1 Bolt				107	128	171	213
						$\min\left(\frac{X1}{e - 9,99mm}; \frac{X2}{85mm - e}; \frac{110}{e \times k_{mod}}\right)$			

e is to insert in [mm]; e ≥ 10mm

negativ values shall not be considered

Connection with bolt

1 Angle Bracket ABR90 per connection				
factor for:	F <sub>1</sub>	F <sub>2/3</sub>	F <sub>4</sub>	F <sub>5</sub>
k <sub>ax</sub>	1,00	-	e/20	e/95
k <sub>lat</sub>	-	-	1,00	1,00

For each bolt it's needed to check:  $R_{bolt,d,lateral} \geq k_{lat} \times F_{i,d}$ ;  $R_{bolt,d,axial} \geq k_{ax} \times F_{i,d}$ ; and also the combination.

## Annex D2 – AB90

### Product Name:

Product Name	Material reference acc. to clause II-1	Alternative product names
AB90	Steel ref. 1	France: E2/2.5/7091, Germany: 90 o/R
AB90S	Steel ref. 2	-
AB90S2	Steel ref. 3	-

### Connector Size Range:

Model no.	Dimensions [mm]				Holes flange A		Holes flange B	
	A	B	C	Thickness	Ø5	Ø11	Ø5	Ø11
AB90	88	88	65	2,5	6	3	9	2

### Drawing:

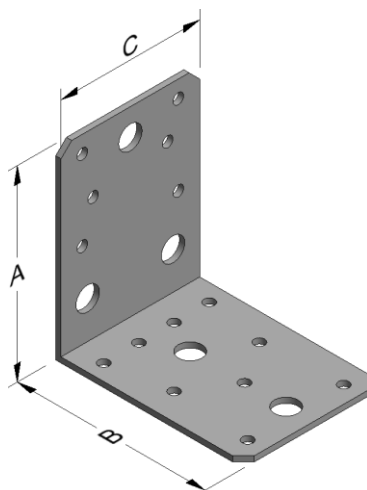

### Nailing pattern:

	Nailing pattern 1	Nailing pattern 2	Nailing pattern 3	Nailing pattern 4	Nailing pattern 5
Flange A:					
Flange B:					
	Beam to beam Maximum nailing	Beam to beam Minimum nailing	Beam (A) to column (B)	Trimmer connection	Beam (B) to rigid support (A) Bolts

Table D2-1 Modified characteristic capacity timber beam to timber beam – 2 Angle Brackets

2 Angle Brackets AB90 per connection			Modified characteristic capacity per connection (kN)						
Nailing Pattern	Number of fasteners		Load duration	$R_{1,k} \times k_{mod}$		$R_{2/3,k} \times k_{mod}$		$R_{4/5,k} \times k_{mod}$	
	Flange A	Flange B		CNA Connector nail					
				4,0x40	4,0x60	4,0x40	4,0x60	4,0x40	4,0x60
Nailing pattern 2	4	4	P	2,2	3,1	3,3	4,4	$\frac{1,1 \cdot b + 38}{e - 2,5}$ max 4,4	$\frac{1,5 \cdot b + 41}{e - 2,5}$ max 4,9
			L	2,4	3,4	3,9	5,2	$\frac{1,2 \cdot b + 39}{e - 2,5}$ max 5,1	$\frac{1,7 \cdot b + 43}{e - 2,5}$ max 5,3
			M	2,7	3,8	4,5	5,9	$\frac{1,3 \cdot b + 40}{e - 2,5}$ max 5,7	$\frac{1,9 \cdot b + 44}{e - 2,5}$ max 5,7
			S	2,9	4,1	5,0	6,6	$\frac{1,4 \cdot b + 41}{e - 2,5}$ max 6,0	$\frac{2,1 \cdot b + 45}{e - 2,5}$ max 6,0
			I	3,3	4,8	6,1	8,1	$\frac{1,6 \cdot b + 42}{e - 2,5}$ max 6,7	$\frac{2,4 \cdot b + 48}{e - 2,5}$ max 6,7
Nailing pattern 1	6	9	P	3,5	5,2	4,3	6,3	$\frac{1,8 \cdot b + 43}{e - 2,5}$ max 4,9	$\frac{2,6 \cdot b + 49}{e - 2,5}$ max 4,9
			L	3,9	5,9	5,0	7,3	$\frac{2,0 \cdot b + 45}{e - 2,5}$ max 5,3	$\frac{3,0 \cdot b + 52}{e - 2,5}$ max 5,3
			M	4,4	6,6	5,8	8,4	$\frac{2,2 \cdot b + 46}{e - 2,5}$ max 5,7	$\frac{3,3 \cdot b + 55}{e - 2,5}$ max 5,7
			S	4,8	6,9	6,5	9,4	$\frac{2,4 \cdot b + 48}{e - 2,5}$ max 6,0	$\frac{3,5 \cdot b + 56}{e - 2,5}$ max 6,0
			I	5,6	6,9	7,9	11,5	$\frac{2,8 \cdot b + 51}{e - 2,5}$ max 6,7	$\frac{3,5 \cdot b + 56}{e - 2,5}$ max 6,7

b and e are in mm

Wane may not occur under the angle brackets.

Table D2-2 Modified characteristic capacity timber beam to timber beam – 1 Angle Bracket

1 Angle Bracket AB90 per connection			Modified characteristic capacity per connection (kN)																								
Nailing pattern	Number of fasteners		Load duration	$R_{1,k} \times k_{mod}$		$R_{2/3,k} \times k_{mod}$		$R_{4/5,k} \times k_{mod}$																			
	Flange A	Flange B		CNA Connector nail																							
				4,0x40	4,0x60	4,0x40	4,0x60	4,0x40	4,0x60																		
Nailing pattern 2	4	4	P	$f \leq 93$ : <u>26.6</u> f+43	$f \leq 14$ : <u>44.3</u> f+43	1,7	2,2	<u>20.8</u> e-2,5 max	3,6	5,2																	
				$f > 93$ : <u>20.8</u> f+13	$f > 14$ :																						
			L	$f \leq 47$ : <u>31.1</u> f+43	$f \leq 7$ : <u>51.7</u> f+43	2,0	2,6	<u>20.8</u> e-2,5 max	4,4	6,2																	
				$f > 47$ : <u>20.8</u> f+13	$f > 7$ :																						
			M	$f \leq 29$ : <u>35.5</u> f+43	$f \leq 3$ : <u>59</u> f+43	2,2	3,0	<u>20.8</u> e-2,5 max	5,2	7,1																	
$f > 29$ : <u>20.8</u> f+13	$f > 3$ :																										
S	$f \leq 20$ : <u>40.0</u> f+43		2,5	3,3	<u>20.8</u> e-2,5 max	5,9	8,1																				
	$f > 20$ : <u>20.8</u> f+13	$f > 0$ :																									
I	$f \leq 9$ : <u>48.8</u> f+43		3,1	4,1	<u>20.8</u> e-2,5 max	7,4	10,0																				
	$f > 9$ : <u>20.8</u> f+13	$f > 0$ :																									
Nailing pattern 1	6	9	P	<u>20.8</u> f+13	2,2	3,1	<u>20.8</u> e-2,5 max	9,7	12,6																		
										L	2,5	3,7	<u>20.8</u> e-2,5 max	11,3	14,7												
																M	2,9	4,2	<u>20.8</u> e-2,5 max	12,9	16,8						
																						S	3,2	4,7	<u>20.8</u> e-2,5 max	14,6	19,0

e and f are in mm

Wane may not occur under the angle brackets.

**Table D2-3** *Modified characteristic capacity timber beam to timber column – 1 Angle Bracket*

1 Angle Bracket AB90 per connection				Modified characteristic capacity per connection (kN)		
Nailing pattern	Number of fasteners		Load duration	$R_{1,k} \times k_{mod}$		$R_{2,k} \times k_{mod}$
	Flange A (beam)	Flange B (column)		Flap turned downwards	Flap turned upwards	
				CNA 4,0x40 / CNA 4,0x60		
Nailing pattern 3	4	4	P	3,8	3,4	0,7
			L	4,5	3,6	
			M	4,7	3,8	
			S	4,9	3,9	
			I	5,3	4,2	

End gab: max. 5 mm

**Table D2-4** *Modified characteristic capacity trimmer connection – 2 Angle Brackets*

2 Angle Brackets AB90 per connection				Modified characteristic capacities (kN)	
				$R_{2,3k} \times k_{mod}$	
Nailing pattern	Number of fasteners		Load duration	CNA4,0x40	CNA4,0x60
	Joist flange (A)	Header flange (B)			
Nailing pattern 4	6	9	P	4,3	6,2
			L	5,0	7,2
			M	5,8	8,2
			S	6,5	9,2
			I	7,9	11,5

Wane may not occur under the angle brackets.

Table D2-5 Characteristic capacity timber beam to rigid support – 2 Angle Brackets

2 Angle Brackets AB90 per connection			Characteristic capacities per connection (kN)					$R_{4/5,k}$
			$R_{1,k}$	$R_{2/3,k}$				
Nailing pattern	Number of fasteners		4,0x35 to 4,0x60	CNA connector nails				4,0x35 to 4,0x60
	Flange A	Flange B		4,0x35	4,0x40	4,0x50	4,0x60	
Nailing pattern 5	5	2 Bolts	$5,4/k_{mod}$	4,73	5,03	6,25	6,66	$\max \left\{ \begin{array}{l} R_4^{1)} + R_5^{1)} \\ \min \left\{ \frac{4,5}{k_{mod}}; \frac{R_1}{2} \times \frac{b}{e} \right\} \end{array} \right.$ 1) for e

Connection with bolt

2 Angle Bracket AB90 per connection				
factor for:	$F_1$	$F_{2/3}$	$F_{4/5,bolt1}$	$F_{4/5,bolt2}$
$k_{ax}$	0,77	-	$1,53xe/b$	0,33
$k_{lat}$	-	see description	-	1,00

For each bolt it's needed to check:  $R_{bolt,d,lateral} \geq k_{lat} \times F_{i,d}$ ;  $R_{bolt,d,axial} \geq k_{ax} \times F_{i,d}$ ; and also the combination.

The connections with bolts has to be checked as following:

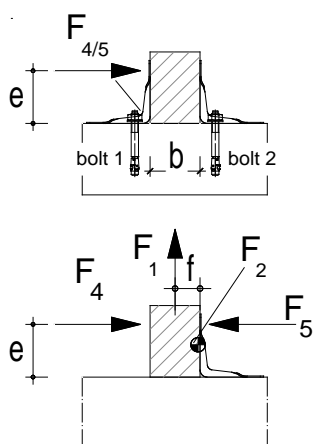
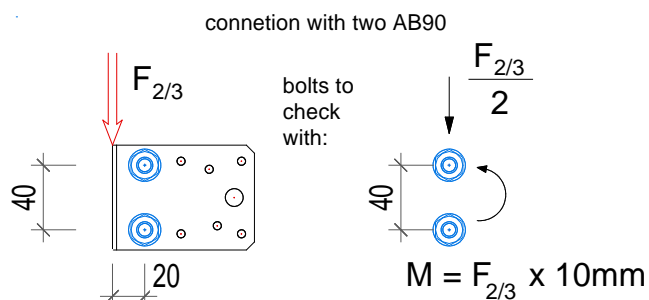



Table D2-6 Characteristic capacity timber beam to rigid support – 1 Angle Bracket

1 Angle Bracket AB90 per connection			Characteristic capacities per connection (kN)																										
Nailing pattern	Number of fasteners		R <sub>1,k</sub>	R <sub>4,k</sub>	R <sub>2/3,k</sub>	R <sub>5,k</sub>																							
	Flange A	Flange B	4,0x35 to 4,0x60	4,0x35 to 4,0x60	CNA connector nails 4,0x35 to 4,0x60	4,0x35	4,0x40	4,0x50	4,0x60																				
Nailing pattern 5	5	2 bolts	19,9 / ((f + 16) x k <sub>mod</sub> )	45,2 / (e x k <sub>mod</sub> )	Half of the values for a connection with 2 AB90, if the timber is prevented from rotation, otherwise R <sub>2/3</sub> =0,0kN	<table border="1"> <tr> <td colspan="4">X1=</td> </tr> <tr> <td>123</td> <td>148</td> <td>197</td> <td>246</td> </tr> <tr> <td colspan="4">X2=</td> </tr> <tr> <td>63</td> <td>75</td> <td>100</td> <td>125</td> </tr> <tr> <td colspan="4"> <math>\min\left(\frac{X1}{e - 9,99mm}; \frac{X2}{85mm - e}; \frac{110}{e \times k_{mod}}\right)</math> </td> </tr> </table>				X1=				123	148	197	246	X2=				63	75	100	125	$\min\left(\frac{X1}{e - 9,99mm}; \frac{X2}{85mm - e}; \frac{110}{e \times k_{mod}}\right)$			
X1=																													
123	148	197	246																										
X2=																													
63	75	100	125																										
$\min\left(\frac{X1}{e - 9,99mm}; \frac{X2}{85mm - e}; \frac{110}{e \times k_{mod}}\right)$																													

e is to insert in [mm]; e ≥ 10mm  
negativ values shall not be considered

Connection with bolt

1 Angle Bracket AB90 per connection				
factor for:	F <sub>1</sub>	F <sub>2/3</sub>	F <sub>4</sub>	F <sub>5</sub>
k <sub>ax</sub>	1,53	-	e/30	e/26
k <sub>lat</sub>	-	see description	1,00	1,00

For each bolt it's needed to check: R<sub>bolt,d,lateral</sub> ≥ k<sub>lat</sub> x F<sub>i,d</sub>; R<sub>bolt,d,axial</sub> ≥ k<sub>ax</sub> x F<sub>i,d</sub>; and also the combination

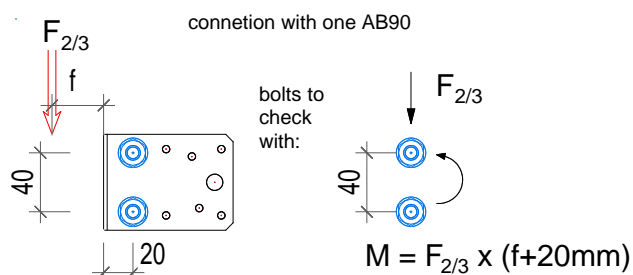

## Annex D3 – ABR105

### Product Name:

Product Name	Material reference acc. to clause II-1	Alternative product names
ABR105	Steel ref. 1	UK: ABR105-R, France: ABR105-R, Germany: 105 m/R
ABR105S	Steel ref. 2	France: E3IX
ABR105S2	Steel ref. 3	-

### Connector Size Range:

Model no.	Dimensions [mm]				Holes flange A		Holes flange B	
	A	B	C	Thickness	Ø5	Ø11	Ø5	Ø11
ABR105	105	105	65	3,0	10	3	14	1

### Drawing:

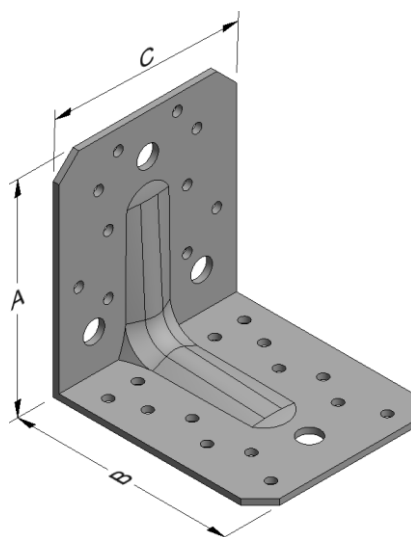

### Nailing pattern:

	Nailing pattern 1	Nailing pattern 2	Nailing pattern 3	Nailing pattern 4	Nailing pattern 5
Flange A:					
Flange B:					
	Beam to beam Maximum nailing	Beam to beam Minimum nailing	Beam (A) to rigid support (B) Maximum nailing	Beam (A) to rigid support (B) Minimum nailing	Beam (A) to column (B)

Table D3-1 Modified characteristic capacity timber beam to timber beam – 2 Angle Brackets

2 Angle Brackets ABR105 per connection			Modified characteristic capacity per connection (kN)							
Nailing pattern	Number of fasteners		Load duration	$R_{1,k} \times k_{mod}$		$R_{2/3,k} \times k_{mod}$		$R_{4/5,k} \times k_{mod}$		
	Flange A	Flange B		CNA Connector nail						
				4,0x40	4,0x60	4,0x40	4,0x60	4,0x40	4,0x60	
Nailing pattern 2	6	6	P	3,6	5,9	4,6	7,0	$\frac{10,2 \cdot b + 601}{e - 10,7}$ max 6,8	$\frac{11,5 \cdot b + 599}{e - 10,7}$ max 9,0	
				3,6	5,9					
			L	4,1	6,9	5,4	8,1	$\frac{10,6 \cdot b + 601}{e - 10,7}$ max 7,3	$\frac{12,0 \cdot b + 598}{e - 10,7}$ max 10,0	
				4,1	6,9					
			M	4,7	7,9	6,2	9,3	$\frac{10,9 \cdot b + 600}{e - 10,7}$ max 7,9	$\frac{12,5 \cdot b + 597}{e - 10,7}$ max 10,9	
				4,7	7,9					
	S	5,3	8,9	6,9	10,5	$\frac{11,2 \cdot b + 599}{e - 10,7}$ max 8,5	$\frac{13,0 \cdot b + 596}{e - 10,7}$ max 11,9			
		5,3	8,9							
	I	6,5	10,8	8,5	12,8	$\frac{11,8 \cdot b + 598}{e - 10,7}$ max 9,6	$\frac{14,1 \cdot b + 595}{e - 10,7}$ max 13,7			
		6,5	10,4							
	Nailing pattern 1	10	14	P	6,5	10,7	8,7	12,2	$\frac{11,0 \cdot b + 568}{e - 10,7}$ max 9,7	$\frac{12,8 \cdot b + 562}{e - 10,7}$ max 14,0
					2,8	6,5				
L				7,5	12,5	10,2	14,2	$\frac{11,5 \cdot b + 566}{e - 10,7}$ max 10,8	$\frac{13,5 \cdot b + 559}{e - 10,7}$ max 15,8	
				3,6	8,4					
M				8,6	14,3	11,6	16,2	$\frac{11,9 \cdot b + 565}{e - 10,7}$ max 11,9	$\frac{14,3 \cdot b + 557}{e - 10,7}$ max 17,5	
				4,5	10,6					
S		9,7	16,1	13,1	18,2	$\frac{12,4 \cdot b + 563}{e - 10,7}$ max 12,9	$\frac{15,0 \cdot b + 554}{e - 10,7}$ max 19,3			
		5,5	11,7							
I		11,9	19,7	16,0	22,3	$\frac{13,3 \cdot b + 560}{e - 10,7}$ max 15,1	$\frac{16,5 \cdot b + 549}{e - 10,7}$ max 22,8			
		7,7	13,8							

b and e are in mm.

■ When the purlin has a wane on the side towards the Angle Bracket with an extent from the bottom up to the lower nail the value in the grey square is valid.

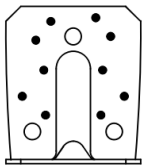
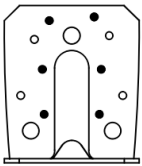
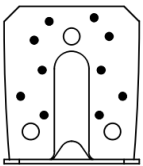
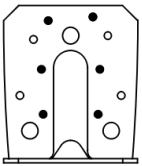
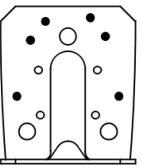
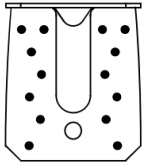
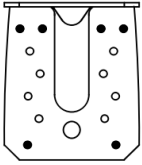
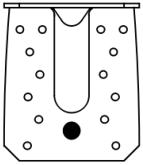
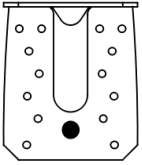
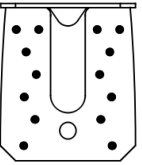
Table D3-2 Modified characteristic capacity timber beam to timber beam – 1 Angle Bracket Load duration P

1 Angle Bracket ABR105 per connection			Modified characteristic capacity per connection (kN)								
Nailing pattern	Number of fasteners		Load duration	$R_{1,k} \times k_{mod}$		$R_{2/3,k} \times k_{mod}$		$R_{4,k} \times k_{mod}$		$R_{5,k} \times k_{mod}$	
	Flange A	Flange B		4,0x40	4,0x60	4,0x40	4,0x60	CNA Connector nail		4,0x40	4,0x60
								4,0x40	4,0x60	4,0x40	4,0x60
Nailing pattern 2	6	6	P	$f \leq 25$ : $\frac{162}{f+60}$	$f \leq 35$ : $\frac{215}{f+60}$	2,3	3,5	$e < 37,5$ : $\frac{52}{37,5-e}$	$e < 37,5$ : $\frac{87}{37,5-e}$	$e \leq 76$ : $\frac{47}{85-e}$	$e \leq 74$ : $\frac{77}{85-e}$
								$e \leq 74$ : 2,2	$e \leq 76$ : 2,8	$76 < e \leq 1,89 \cdot b + 3$ : 5,4	$74 < e \leq 1,69 \cdot b + 8$ : 6,8
				$74 < e \leq 127$ : $\frac{162}{e}$	$76 < e \leq 137$ : $\frac{215}{e}$						
				$f > 25$ : $\frac{47}{f}$	$f > 35$ : $\frac{77}{f}$			$127 < e \leq 500$ : $\frac{47}{e-85}$	$137 < e \leq 500$ : $\frac{77}{e-85}$	$e > 1,89 \cdot b + 3$ : $\frac{10,2 \cdot b - 446}{e-85}$	$e > 1,69 \cdot b + 8$ : $\frac{11,5 \cdot b - 525}{e-85}$
Nailing pattern 1	10	14	P	$f \leq 40$ : $\frac{188}{f+60}$	$f \leq 55$ : $\frac{259}{f+60}$	4,4	6,1	$e < 37,5$ : $\frac{92}{37,5-e}$	$e < 37,5$ : $\frac{153}{37,5-e}$	$e \leq 72$ : $\frac{82}{85-e}$	$e \leq 68$ : $\frac{137}{85-e}$
								$e \leq 29$ : 6,6	$e \leq 31$ : 8,5	$72 < e \leq 1,78 \cdot b + 2$ : 6,2	$68 < e \leq 1,59 \cdot b + 6$ : 8,1
				$29 < e \leq 166$ : $\frac{190}{e}$	$31 < e \leq 187$ : $\frac{261}{e}$						
				$f > 40$ : $\frac{73}{f}$	$f > 55$ : $\frac{122}{f}$			$166 < e \leq 500$ : $\frac{82}{e-85}$	$e > 187$ : $\frac{137}{e-85}$	$e > 1,78 \cdot b + 2$ : $\frac{11,0 \cdot b - 513}{e-85}$	$e > 1,59 \cdot b + 6$ : $\frac{12,8 \cdot b - 636}{e-85}$

b, e and f are in mm.

When the purlin has a wane on the side towards the Angle Bracket with an extent from the bottom up to the lower nail the formula in the grey square shall be checked additionally.

Table D3-3 Modified characteristic capacity timber beam to timber beam – 1 Angle Bracket Load duration L

1 Angle Bracket ABR105 per connection			Modified characteristic capacity per connection (kN)								
Nailing pattern	Number of fasteners		Load duration	$R_{1,k} \times k_{mod}$		$R_{2/3,k} \times k_{mod}$		$R_{4,k} \times k_{mod}$		$R_{5,k} \times k_{mod}$	
	Flange A	Flange B		4,0x40	4,0x60	4,0x40	4,0x60	4,0x40	4,0x60	4,0x40	4,0x60
Nailing pattern 2	6	6	L	$f \leq 28$ : $\frac{175}{f+60}$	$f \leq 39$ : $\frac{237}{f+60}$	2,7	4,1	$e < 37,5$ : $\frac{61}{37,5-e}$	$e < 37,5$ : $\frac{101}{37,5-e}$	$e \leq 76$ : $\frac{54}{85-e}$	$e \leq 73$ : $\frac{90}{85-e}$
								$e \leq 68$ : 2,6	$e \leq 72$ : 3,3	76 < e ≤ 1,83 · b + 4:	73 < e ≤ 1,62 · b + 9:
				$68 < e \leq 132$ : $\frac{175}{e}$	$72 < e \leq 142$ : $\frac{237}{e}$			5,8	7,4		
				$f > 28$ : $\frac{54}{f}$	$f > 39$ : $\frac{90}{f}$			$132 < e \leq 500$ : $\frac{54}{e-85}$	$142 < e \leq 500$ : $\frac{90}{e-85}$	$e > 1,83 \cdot b + 4$ : $\frac{10,6 \cdot b - 466}{e-85}$	$e > 1,62 \cdot b + 9$ : $\frac{12,0 \cdot b - 558}{e-85}$
Nailing pattern 1	10	14	L	$f \leq 44$ : $\frac{206}{f+60}$	$f \leq 60$ : $\frac{289}{f+60}$	5,1	7,1	$e < 37,5$ : $\frac{107}{37,5-e}$	$e < 37,5$ : $\frac{179}{37,5-e}$	$e \leq 71$ : $\frac{96}{85-e}$	$e \leq 67$ : $\frac{159}{85-e}$
								$e \leq 27$ : 7,7	$e \leq 29$ : 9,9	71 < e ≤ 1,72 · b + 3:	67 < e ≤ 1,53 · b + 7:
				$27 < e \leq 175$ : $\frac{208}{e}$	$29 < e \leq 136$ : $\frac{291}{e}$			6,7	8,9		
				$f > 44$ : $\frac{85}{f}$	$f > 60$ : $\frac{142}{f}$			$136 < e \leq 245$ : $\frac{245}{e-32,5}$	$e > 245$ : $\frac{159}{e-85}$	$e > 1,72 \cdot b + 3$ : $\frac{11,5 \cdot b - 544}{e-85}$	$e > 1,53 \cdot b + 7$ : $\frac{13,5 \cdot b - 688}{e-85}$

b, e and f are in mm.

When the purlin has a wane on the side towards the Angle Bracket with an extent from the bottom up to the lower nail the formula in the grey square shall be checked additionally.

Table D3-4 Modified characteristic capacity timber beam to timber beam – 1 Angle Bracket Load duration M

1 Angle Bracket ABR105 per connection			Modified characteristic capacity per connection (kN)								
Nailing pattern	Number of fasteners		Load duration	$R_{1,k} \times k_{mod}$		$R_{2/3,k} \times k_{mod}$		$R_{4,k} \times k_{mod}$		$R_{5,k} \times k_{mod}$	
	Flange A	Flange B		4,0x40	4,0x60	4,0x40	4,0x60	CNA Connector nail		4,0x40	4,0x60
								4,0x40	4,0x60	4,0x40	4,0x60
Nailing pattern 2	6	6	M	$f \leq 31$ : $\frac{118}{f+60}$	$f \leq 42$ : $\frac{259}{f+60}$	3,1	4,7	$e < 37,5$ : $\frac{70}{37,5-e}$	$e < 37,5$ : $\frac{116}{37,5-e}$	$e \leq 75$ : $\frac{62}{85-e}$	$e \leq 72$ : $\frac{103}{85-e}$
								$75 < e \leq 1,77 \cdot b + 6$ :	$72 < e \leq 1,57 \cdot b + 11$ :		
				$e \leq 64$ : 2,9	$e \leq 69$ : 3,8			6,1	8,0		
				$64 < e \leq 135$ : $\frac{188}{e}$	$69 < e \leq 146$ : $\frac{259}{e}$					$e > 1,77 \cdot b + 6$ :	$e > 1,57 \cdot b + 11$ :
				$f > 31$ : $\frac{62}{f}$	$f > 42$ : $\frac{103}{f}$			$135 < e \leq 500$ : $\frac{62}{e-85}$	$146 < e \leq 500$ : $\frac{103}{e-85}$	$\frac{10,9 \cdot b - 486}{e-85}$	$\frac{12,5 \cdot b - 591}{e-85}$
Nailing pattern 1	10	14	M	$f \leq 48$ : $\frac{224}{f+60}$	$f \leq 65$ : $\frac{318}{f+60}$	5,8	8,1	$e < 37,5$ : $\frac{123}{37,5-e}$	$e < 37,5$ : $\frac{204}{37,5-e}$	$e \leq 70$ : $\frac{110}{85-e}$	$e \leq 66$ : $\frac{182}{85-e}$
								$e \leq 26$ : 8,8	$e \leq 28$ : 11,3	$70 < e \leq 1,67 \cdot b + 4$ :	$66 < e \leq 1,48 \cdot b + 8$ :
				$26 < e \leq 183$ : $\frac{226}{e}$	$28 < e \leq 104$ : $\frac{321}{e}$			7,1	9,6		
				$183 < e \leq 500$ : $\frac{110}{e-85}$	$104 < e \leq 500$ : $\frac{245}{e-32,5}$					$e > 1,67 \cdot b + 4$ :	$e > 1,48 \cdot b + 8$ :
				$f > 48$ : $\frac{97}{f}$	$f > 65$ : $\frac{162}{f}$					$\frac{11,9 \cdot b - 575}{e-85}$	$\frac{14,3 \cdot b - 739}{e-85}$

b, e and f are in mm.

■ When the purlin has a wane on the side towards the Angle Bracket with an extent from the bottom up to the lower nail the formula in the grey square shall be checked additionally.

Table D3-5 Modified characteristic capacity timber beam to timber beam – 1 Angle Bracket Load duration S

1 Angle Bracket ABR105 per connection			Modified characteristic capacity per connection (kN)								
Nailing pattern	Number of fasteners		Load duration	$R_{1,k} \times k_{mod}$		$R_{2/3,k} \times k_{mod}$		$R_{4,k} \times k_{mod}$		$R_{5,k} \times k_{mod}$	
	Flange A	Flange B		4,0x40	4,0x60	4,0x40	4,0x60	CNA Connector nail		4,0x40	4,0x60
								4,0x40	4,0x60	4,0x40	4,0x60
Nailing pattern 2	6	6	S	$f \leq 33:$ $\frac{202}{f+60}$	$f \leq 44:$ $\frac{281}{f+60}$	3,5	5,2	$e < 37,5:$ $\frac{78}{37,5-e}$	$e < 37,5:$ $\frac{130}{37,5-e}$	$e \leq 74:$ $\frac{70}{85-e}$	$e \leq 71:$ $\frac{116}{85-e}$
								$e \leq 61: 3,3$	$e \leq 66: 4,2$	$74 < e \leq 1,73 \cdot b + 7:$	$71 < e \leq 1,53 \cdot b + 12:$
								$61 < e \leq 139:$ $\frac{202}{e}$	$66 < e \leq 149:$ $\frac{281}{e}$	6,5	8,5
				$f > 33:$ $\frac{70}{f}$	$f > 44:$ $\frac{116}{f}$			$139 < e \leq 500:$ $\frac{70}{e-85}$	$149 < e \leq 500:$ $\frac{116}{e-85}$	$e > 1,73 \cdot b + 7:$ $\frac{11,2 \cdot b - 506}{e-85}$	$e > 1,53 \cdot b + 12:$ $\frac{13,0 \cdot b - 624}{e-85}$
Nailing pattern 1	10	14	S	$f \leq 52:$ $\frac{242}{f+60}$	$f \leq 69:$ $\frac{348}{f+60}$	6,5	9,1	$e < 37,5:$ $\frac{138}{37,5-e}$	$e < 37,5:$ $\frac{230}{37,5-e}$	$e \leq 69:$ $\frac{123}{85-e}$	$e \leq 65:$ $\frac{205}{85-e}$
								$e \leq 25: 9,9$	$e \leq 27: 12,9$	$69 < e \leq 1,63 \cdot b + 5:$	$65 < e \leq 1,44 \cdot b + 9:$
								$25 < e \leq 179:$ $\frac{244}{e}$	$27 < e \leq 87:$ $\frac{351}{e}$	7,6	10,4
								$195 < e \leq 300:$ $\frac{245}{e-32,5}$	$87 < e \leq 500:$ $\frac{245}{e-32,5}$	$e > 1,63 \cdot b + 5:$	$e > 1,44 \cdot b + 9:$
$300 < e \leq 500:$ $\frac{123}{e-85}$	$\frac{12,4 \cdot b - 606}{e-85}$	$\frac{15,0 \cdot b - 791}{e-85}$									

b, e and f are in mm.

When the purlin has a wane on the side towards the Angle Bracket with an extent from the bottom up to the lower nail the formula in the grey square shall be checked additionally.

Table D3-6 Modified characteristic capacity timber beam to timber beam – 1 Angle Bracket Load duration I

1 Angle Bracket ABR105 per connection			Modified characteristic capacity per connection (kN)								
Nailing pattern	Number of fasteners		Load duration	$R_{1,k} \times k_{mod}$		$R_{2/3,k} \times k_{mod}$		$R_{4,k} \times k_{mod}$		$R_{5,k} \times k_{mod}$	
	Flange A	Flange B		4,0x40	4,0x60	4,0x40	4,0x60	CNA Connector nail		4,0x40	4,0x60
Nailing pattern 2	6	6	I	$f \leq 38$ : $\frac{228}{f+60}$	$f \leq 49$ : $\frac{325}{f+60}$	4,2	6,4	$e < 37,5$ : $\frac{96}{37,5-e}$	$e < 37,5$ : $\frac{159}{37,5-e}$	$e \leq 73$ : $\frac{85}{85-e}$	$e \leq 70$ : $\frac{142}{85-e}$
								$e \leq 57$ : 4	$e \leq 63$ : 5,2	$73 < e \leq 1,65 \cdot b + 9$ :	$70 < e \leq 1,45 \cdot b + 14$ :
				$57 < e \leq 145$ : $\frac{228}{e}$	$63 < e \leq 101$ : $\frac{325}{e}$			7,2	9,7		
				$145 < e \leq 500$ : $\frac{85}{e-85}$	$101 < e \leq 190$ : $\frac{245}{e-32,5}$			$e > 1,65 \cdot b + 9$ : $\frac{11,8 \cdot b - 545}{e-85}$	$e > 1,45 \cdot b + 14$ : $\frac{14,1 \cdot b - 690}{e-85}$		
				$f > 38$ : $\frac{85}{f}$	$f > 49$ : $\frac{142}{f}$			$190 < e \leq 500$ : $\frac{142}{e-85}$			
Nailing pattern 1	10	14	I	$f \leq 59$ : $\frac{277}{f+60}$	$f \leq 76$ : $\frac{407}{f+60}$	8,0	11,2	$e < 37,5$ : $\frac{169}{37,5-e}$	$e < 37,5$ : $\frac{281}{37,5-e}$	$e \leq 67$ : $\frac{151}{85-e}$	$e \leq 64$ : $\frac{250}{85-e}$
								$e \leq 23$ : 12,1	$e \leq 26$ : 15,8	$67 < e \leq 1,55 \cdot b + 7$ :	$63 < e \leq 1,37 \cdot b + 11$ :
				$23 < e \leq 110$ : $\frac{280}{e}$	$26 < e \leq 82$ : $\frac{407}{e}$			8,6	12,0		
				$110 < e \leq 335$ : $\frac{245}{e-32,5}$	$82 < e \leq 500$ : $\frac{245}{e-32,5}$			$e > 1,55 \cdot b + 7$ : $\frac{13,3 \cdot b - 668}{e-85}$	$e > 1,37 \cdot b + 11$ : $\frac{16,5 \cdot b - 894}{e-85}$		
				$f > 59$ : $\frac{134}{f}$	$f > 76$ : $\frac{223}{f}$			$335 < e \leq 500$ : $\frac{151}{e-85}$			

b, e and f are in mm.

When the purlin has a wane on the side towards the Angle Bracket with an extent from the bottom up to the lower nail the formula in the grey square shall be checked additionally.



Table D3-7 Modified characteristic capacity timber beam to timber column – 1 Angle Bracket

1 Angle Bracket ABR105 per connection				Modified characteristic capacity per connection (kN)			
				$R_{1,k} \times k_{mod}$		$R_{2,k} \times k_{mod}$	
Nailing pattern	Number of fasteners		Load duration	CNA4,0x40	CNA4,0x60	CNA4,0x40	CNA4,0x60
	Flange A (beam)	Flange B (column)					
Nailing pattern 5	6	14	P	9,6	10,2	0,9	1,5
			L	11,2	11,9	1,0	1,7
			M	12,8	13,6	1,2	2,0
			S	14,4	15,3	1,3	2,2
			I	17,6	18,7	1,6	2,7

Table D3-8 Characteristic capacity timber beam to rigid support – 2 Angle Brackets

2 Angle Brackets ABR105 per connection			Characteristic capacities per connection (kN)								
			$R_{1,k}$				$R_{2/3,k}$				$R_{4/5,k}$
Nailing pattern	Number of fasteners		CNA connector nails								
	Flange A	Flange B	4,0x35	4,0x40	4,0x50	4,0x60	4,0x35	4,0x40	4,0x50	4,0x60	4,0x35 to 4,0x60
Nailing pattern 3	10	1 Bolt	min of:				2,25	2,68	3,55	4,37	$\max \left\{ \begin{array}{l} R_4^{1)} + R_5^{1)} \\ \min \left\{ \frac{4,6}{k_{mod}}; \frac{R_1}{2} \times \frac{b}{e} \right\} \end{array} \right.$
			4,08	4,88	6,48	8,08					
Nailing pattern 4	6	1 Bolt	1,9	2,28	3,02	3,78	1,6	1,9	2,52	3,09	$7,7/k_{mod}$

Connection with bolt

2 Angle Brackets ABR105 per connection				
factor for:	$F_1$	$F_{2/3}$	$F_{4/5,bolt1}$	$F_{4/5,bolt2}$
$k_{ax}$	0,50	-	$e/b$	0,13
$k_{lat}$	-	0,5	-	1,00

For each bolt it's needed to check:  $R_{bolt,d,lateral} \geq k_{lat} \times F_{i,d}$ ;  $R_{bolt,d,axial} \geq k_{ax} \times F_{i,d}$ ; and also the combination.

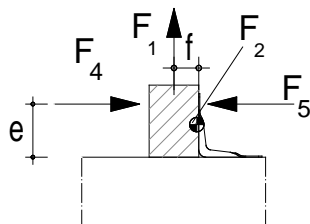
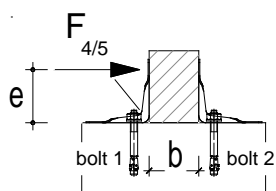

**Table D3-9 Characteristic capacity timber beam to rigid support – 1 Angle Bracket**

1 Angle Bracket ABR105 per connection			Characteristic capacities per connection (kN)													
			R <sub>1,k</sub>		R <sub>4,k</sub>		R <sub>2/3,k</sub>				R <sub>5,k</sub>					
Nailing pattern	Number of fasteners		4,0x35 to 4,0x60	4,0x35 to 4,0x60	CNA connector nails				4,0x35	4,0x40	4,0x50	4,0x60	4,0x35	4,0x40	4,0x50	4,0x60
	Flange A	Flange B			4,0x35	4,0x40	4,0x50	4,0x60								
Nailing pattern 3	10	1 Bolt	45,8 / ((f +81) x k <sub>mod</sub> )	45,28/ (e x k <sub>mod</sub> )	Half of the values for a connection with 2 ABR105, if the timber is prevented from rotation, otherwise R <sub>2/3</sub> =0,0kN				X1=							
Nailing pattern 4	6	1 Bolt							245   294   392   490							
						X2=										
						173   208   277   347										
						$\min \left( \frac{X1}{e - 9,99mm}; \frac{X2}{101mm - e}; \frac{265}{e \times k_{mod}} \right)$										

e is to insert in [mm]; e≥ 10mm  
negativ values shall not be considered

Connection with bolt

1 Angle Bracket ABR105 per connection				
factor for:	F <sub>1</sub>	F <sub>2/3</sub>	F <sub>4</sub>	F <sub>5</sub>
k <sub>ax</sub>	1,00	-	e/15	e/80
k <sub>lat</sub>	-	-	1,00	1,00

For each bolt it's needed to check: R<sub>bolt,d,lateral</sub> ≥ k<sub>lat</sub> x F<sub>i,d</sub>; R<sub>bolt,d,axial</sub> ≥ k<sub>ax</sub> x F<sub>i,d</sub>; and also the combination.

## Annex D4 – AB105

### Product Name:

Product Name	Material reference acc. to clause II-1	Alternative product names
AB105	Steel ref. 1	France: AB105-R, Germany: 105 o/R
AB105S	Steel ref. 2	-
AB105S2	Steel ref. 3	-

### Connector Size Range:

Model no.	Dimensions [mm]				Holes flange A		Holes flange B	
	A	B	C	Thickness	Ø5	Ø11	Ø5	Ø11
AB105	103	103	90	3,0	8	3	11	3

### Drawing:

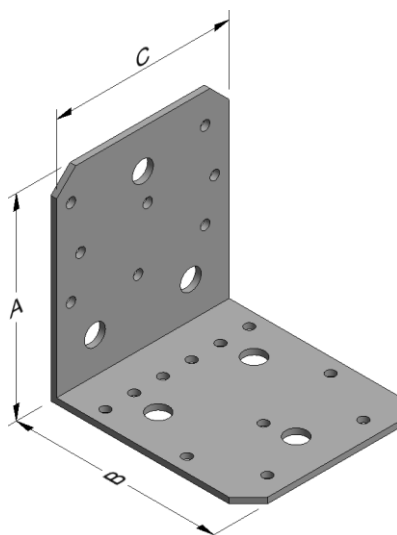

### Nailing pattern:

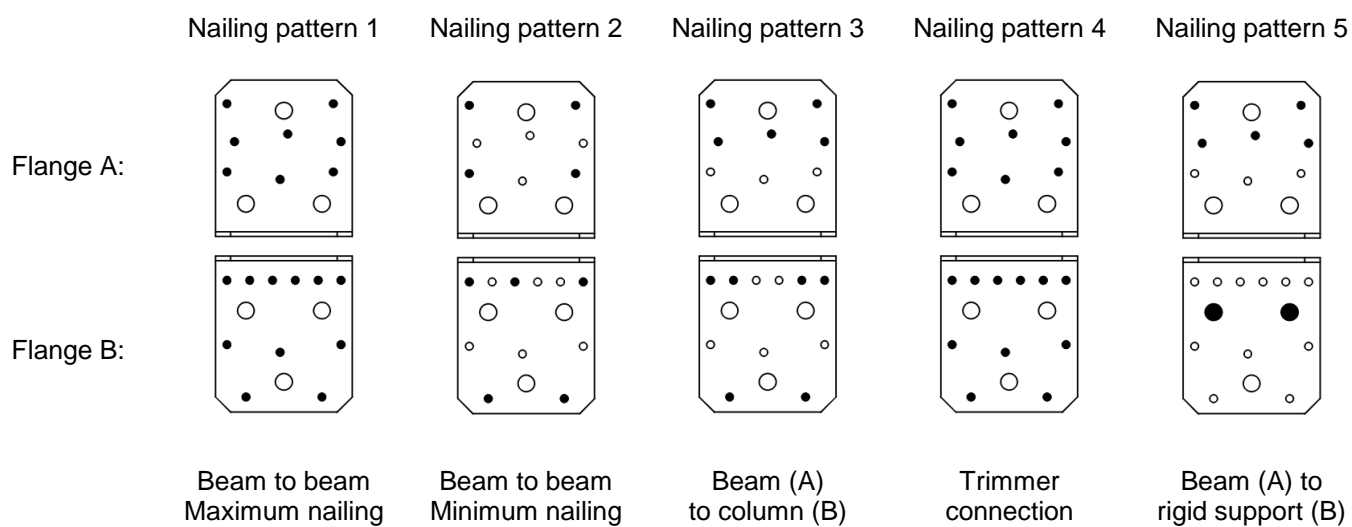

Table D4-1 Modified characteristic capacity timber beam to timber beam – 2 Angle Brackets

2 Angle Brackets AB105 per connection			Modified characteristic capacity per connection (kN)						
Nailing pattern	Number of fasteners		Load duration	$R_{1,k} \times k_{mod}$		$R_{2/3,k} \times k_{mod}$		$R_{4/5,k} \times k_{mod}$	
	Flange A	Flange B		CNA Connector nail					
				4,0x40	4,0x60	4,0x40	4,0x60	4,0x40	4,0x60
Nailing pattern 2	4	6	P	3,6	5,1	2,4	4,5	$\frac{1,9 \cdot b + 75}{e - 2,5}$ max 5,5	$\frac{2,6 \cdot b + 80}{e - 2,5}$ max 7,1
			L	4,1	5,7	2,8	5,3	$\frac{2,0 \cdot b + 76}{e - 2,5}$ max 6,4	$\frac{2,9 \cdot b + 83}{e - 2,5}$ max 8,3
			M	4,4	6,3	3,2	6,1	$\frac{2,2 \cdot b + 77}{e - 2,5}$ max 7,3	$\frac{3,2 \cdot b + 85}{e - 2,5}$ max 9,4
			S	4,8	6,9	3,6	6,8	$\frac{2,4 \cdot b + 79}{e - 2,5}$ max 8,2	$\frac{3,4 \cdot b + 87}{e - 2,5}$ max 10,3
			I	5,5	8,1	4,5	8,3	$\frac{2,7 \cdot b + 82}{e - 2,5}$ max 10,1	$\frac{4,0 \cdot b + 92}{e - 2,5}$ max 11,4
Nailing pattern 1	8	11	P	5,8	8,7	8,0	10,9	$\frac{2,9 \cdot b + 83}{e - 2,5}$ max 8,4	$\frac{4,3 \cdot b + 94}{e - 2,5}$ max 8,4
			L	6,6	9,8	9,3	12,7	$\frac{3,3 \cdot b + 86}{e - 2,5}$ max 9,1	$\frac{4,9 \cdot b + 99}{e - 2,5}$ max 9,1
			M	7,3	11,0	10,6	14,6	$\frac{3,6 \cdot b + 89}{e - 2,5}$ max 9,7	$\frac{5,5 \cdot b + 104}{e - 2,5}$ max 9,7
			S	8,0	12,2	12,0	16,4	$\frac{4,0 \cdot b + 92}{e - 2,5}$ max 10,3	$\frac{6,1 \cdot b + 108}{e - 2,5}$ max 10,3
			I	9,4	13,6	14,6	20,0	$\frac{4,7 \cdot b + 97}{e - 2,5}$ max 11,4	$\frac{6,8 \cdot b + 114}{e - 2,5}$ max 11,4

b and e are in mm

Wane may not occur under the angle brackets.

Table D4-2 Modified characteristic capacity timber beam to timber beam – 1 Angle Bracket

1 Angle Bracket AB105 per connection			Modified characteristic capacity per connection (kN)																	
Nailing pattern	Number of fasteners		Load duration	$R_{1,k} \times k_{mod}$		$R_{2/3,k} \times k_{mod}$		$R_{4/5,k} \times k_{mod}$												
	Flange A	Flange B		CNA Connector nail																
			4,0x40	4,0x60	4,0x40	4,0x60	4,0x40	4,0x60												
Nailing pattern 2	4	6	P	$f \leq 80$ : <u>59</u> f+58	$f \leq 17$ : <u>97</u> f+58	1,2	2,3	<u>39,9</u> e-3,0 max	5,2   6,9											
				$f > 80$ : <u>40</u> f+14	$f > 17$ :															
			L	$f \leq 48$ : <u>68</u> f+58	$f \leq 10$ : <u>114</u> f+58	1,4	2,7	<u>39,9</u> e-3,0 max	6,1   8,1											
				$f > 48$ : <u>40</u> f+14	$f > 10$ :															
			M	$f \leq 32$ : <u>78</u> f+58	$f \leq 6$ : <u>130</u> f+58	1,6	3,0	<u>39,9</u> e-3,0 max	7,1   9,3											
				$f > 32$ : <u>40</u> f+14	$f > 6$ :															
S	$f \leq 23$ : <u>88</u> f+58	$f \leq 3$ : <u>146</u> f+58	1,8	3,4	<u>39,9</u> e-3,0 max	8,0   10,5														
	$f > 23$ : <u>40</u> f+14	$f > 3$ :																		
I	$f \leq 12$ : <u>107</u> f+58		2,2	4,2	<u>39,9</u> e-3,0 max	9,8   12,8														
	$f > 12$ : <u>40</u> f+14	$f > 0$ :																		
Nailing pattern 1	8	11	P	<u>39,9</u> e+14	4,0	5,5	<u>39,9</u> e-3,0 max	12,0   15,5												
			L						4,7	6,4	<u>39,9</u> e-3,0 max	14,0   18,1								
			M										5,3	7,3	<u>39,9</u> e-3,0 max	16,0   20,7				
			S														6,0	8,2	<u>39,9</u> e-3,0 max	18,0   23,3
			I																	

e and f are in mm

Wane may not occur under the angle brackets.

**Table D4-3** Modified characteristic capacity timber beam to timber column – 1 Angle Bracket

1 Angle Bracket AB105 per connection				Modified characteristic capacities per connection (kN)				
Nailing pattern	Number of fasteners		Load duration	$R_{1,k} \times k_{mod}$				$R_{2,k} \times k_{mod}$
	Flange A (beam)	Flange B (column)		Flange turned downwards		Flange turned upwards		
				CNA 4,0x40	CNA 4,0x60	CNA 4,0x40	CNA 4,0x60	CNA4,0x40 & 60
Nailing pattern 3	5	6	P	6,0	7,7	6,9	6,9	1,4
			L	7,0	8,2	7,3	7,3	
			M	8,1	8,6	7,6	7,6	
			S	9,1	9,1	7,9	7,9	
			I	9,8	9,8	8,4	8,4	

End gab: max. 5 mm

Table D4-4 Modified characteristic capacity trimmer connection – 2 Angle Brackets

2 Angle Brackets AB105 per connection				Modified characteristic capacity per connection (kN)	
				$R_{2,3k} \times k_{mod}$	
Nailing pattern	Number of fasteners		Load duration	CNA4,0x40	CNA4,0x60
	Joist flange (A)	Header flange (B)			
Nailing pattern 4	8	11	P	8,0	10,9
			L	9,3	12,7
			M	10,6	14,6
			S	12,0	16,4
			I	14,6	20,0

Wane may not occur under the angle brackets.

Table D4-5 Characteristic capacity timber beam to rigid support – 2 Angle Brackets

2 Angle Brackets AB105 per connection			Characteristic capacities per connection (kN)								
Nailing pattern	Number of fasteners		$R_{1,k}$				$R_{2/3,k}$				$R_{4/5,k}$
	Flange A	Flange B	4,0x35	4,0x40	4,0x50	4,0x60	CNA connector nails				4,0x35 to 4,0x60
							4,0x35	4,0x40	4,0x50	4,0x60	
Nailing pattern 5	5	2 Bolts	min of:				4,86	5,18	6,43	6,85	$\max \left\{ \begin{array}{l} R_4^{1)} + R_5^{1)} \\ \min \left\{ \frac{2,0}{k_{mod}}; \frac{R_1}{2} \times \frac{b}{e} \right\} \end{array} \right\}$
			12,3	13,76	17,58	19,76					
			11,3/k <sub>mod</sub>								
											1) for e

Connection with bolt

2 Angle Brackets AB105 per connection				
factor for:	F <sub>1</sub>	F <sub>2/3</sub>	F <sub>4/5,bolt1</sub>	F <sub>4/5,bolt2</sub>
k <sub>ax</sub>	0,79	-	1,58 x e/b	0,47
k <sub>lat</sub>	-	see description	-	1,00

For each bolt it's needed to check:  $R_{bolt,d,lateral} \geq k_{lat} \times F_{i,d}$ ;  $R_{bolt,d,axial} \geq k_{ax} \times F_{i,d}$ ; and also the combination.

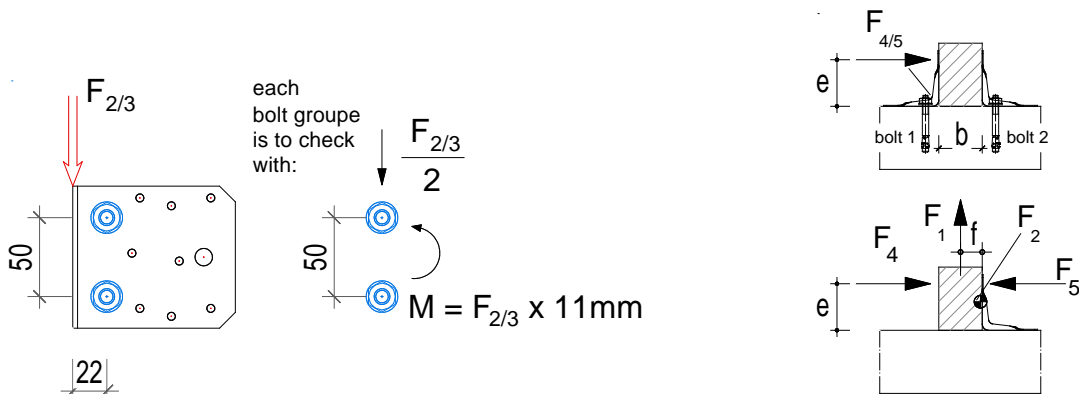

Table D4-6 Characteristic capacity timber beam to rigid support – 1 Angle Bracket

1 Angle Bracket AB105 per connection			Characteristic capacities per connection (kN)														
Nailing pattern	Number of fasteners		$R_{1,k}$	$R_{4,k}$	$R_{2/3,k}$	$R_{5,k}$											
	Flange A	Flange B	4,0x35 to 4,0x60	4,0x35 to 4,0x60	CNA connector nails 4,0x35 to 4,0x60	4,0x35	4,0x40	4,0x50	4,0x60								
Nailing pattern 5	5	2 bolts	$19,9 / ((f+18) \times k_{mod})$	$19,9 / (e \times k_{mod})$	Half of the values for a connection with 2 AB105, if the timber is prevented from rotation, otherwise $R_{2/3}=0,0kN$	$X1 =$ <table border="1"> <tr> <td>158</td> <td>190</td> <td>253</td> <td>316</td> </tr> </table> $X2 =$ <table border="1"> <tr> <td>123</td> <td>148</td> <td>197</td> <td>246</td> </tr> </table> $\min\left(\frac{X1}{e-9,99mm}; \frac{X2}{101mm-e}; \frac{45,2}{e \times k_{mod}}\right)$				158	190	253	316	123	148	197	246
158	190	253	316														
123	148	197	246														

e is to insert in [mm];  $e \geq 10mm$   
negativ values shall not be considered

Connection with bolt

1 Angle Bracket AB105 per connection				
factor for:	$F_1$	$F_{2/3}$	$F_4$	$F_5$
$k_{ax}$	1,58	0,00	$e/21$	$e/28$
$k_{lat}$	-	see description	1,00	1,00

For each bolt it's needed to check:  $R_{bolt,d,lateral} \geq k_{lat} \times F_{i,d}$ ;  $R_{bolt,d,axial} \geq k_{ax} \times F_{i,d}$ ; and also the combination.

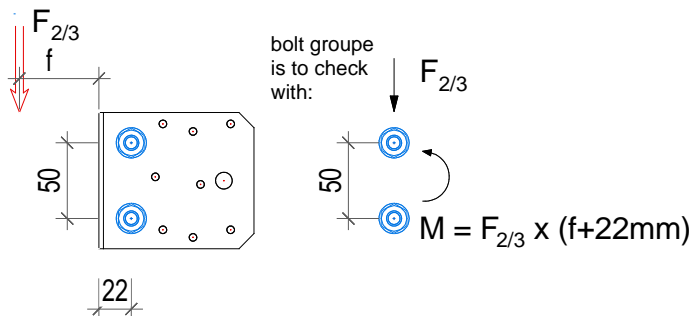



## Annex D5 – ABR70

### Product Name:

Product Name	Material reference acc. to clause II-1	Alternative product names
ABR70	Steel ref. 1	France: EB/7070, Germany: 70 m/R
ABR70S	Steel ref. 2	-
ABR70S2	Steel ref. 3	-

### Connector Size Range:

Model no.	Dimensions [mm]				Holes flange A		Holes flange B	
	A	B	C	Thickness	Ø5	Ø8,5	Ø5	Ø8,5
ABR70	70	70	55	2,0	6	1	6	1

### Drawing:

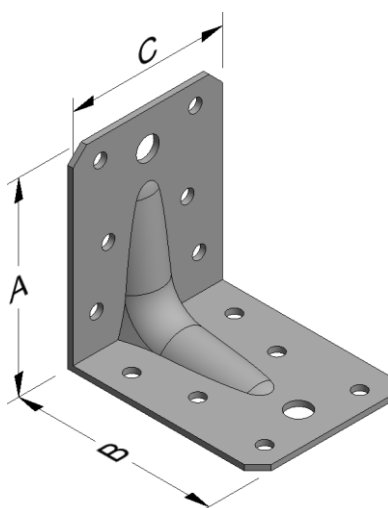

### Nailing pattern:

Nailing pattern 1

Nailing pattern 2

Flange A:

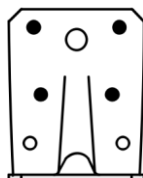
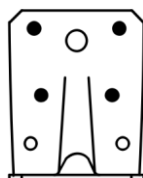

Flange B:

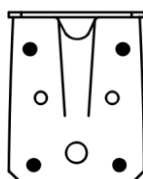
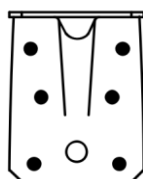

Beam to beam  
Maximum nailing

Beam to beam  
Minimum nailing

Table D5-1 Modified characteristic capacity timber beam to timber beam – 2 Angle Brackets

2 Angle Brackets ABR70 per connection			Modified characteristic capacity per connection (kN)									
Nailing pattern	Number of fasteners		Load duration	$R_{1,k} \times k_{mod}$		$R_{2/3,k} \times k_{mod}$		$R_{4/5,k} \times k_{mod}$				
	Flange A	Flange B		CNA Connector nail								
				4,0x40	4,0x60	4,0x40	4,0x60	4,0x40	4,0x60			
Nailing pattern 2	4	4	P	2,1	3,0	2,9	4,1	$1,04 \cdot b + 155$	$1,48 \cdot b + 161$			
				2,1	3,0			e	e			
			L	2,4	3,4	3,4	4,8	$1,18 \cdot b + 157$	$1,72 \cdot b + 165$			
				2,4	3,4			e	e			
			M	2,4	3,9	3,9	5,5	$1,18 \cdot b + 157$	$1,97 \cdot b + 169$			
				2,4	3,9			e	e			
			S	2,7	4,4	4,4	6,2	$1,33 \cdot b + 159$	$2,21 \cdot b + 172$			
				2,7	4,3			e	e			
			I	3,3	5,4	5,3	7,5	$1,63 \cdot b + 164$	$2,71 \cdot b + 180$			
				3,3	5,1			e	e			
			Nailing pattern 1	4	6	P	3,2	5,3	3,0	4,4	$1,60 \cdot b + 179$	$2,66 \cdot b + 206$
							2,5	4,1			e	e
L	3,7	6,2				3,5	5,1	$1,86 \cdot b + 186$	$3,10 \cdot b + 217$			
	3,1	4,6						e	e			
M	4,3	7,1				4,0	5,8	$2,13 \cdot b + 192$	$3,54 \cdot b + 228$			
	3,4	5,2						e	e			
S	4,8	8,0				4,5	6,6	$2,40 \cdot b + 199$	$3,99 \cdot b + 239$			
	3,7	5,8						e	e			
I	5,9	9,7				5,5	8,0	$2,93 \cdot b + 212$	$4,87 \cdot b + 261$			
	4,4	6,9						e	e			

b and e are in mm.

■ When the purlin has a wane on the side towards the Angle Bracket with an extent from the bottom up to the lower nail the value in the grey square is valid.

Table D5-2 Modified characteristic capacity timber beam to timber beam – 1 Angle Bracket Load duration P

1 Angle Bracket ABR70 per connection			Modified characteristic capacity per connection (kN)								
Nailing pattern	Number of fasteners		Load duration	$R_{1,k} \times k_{mod}$		$R_{2/3,k} \times k_{mod}$		$R_{4,k} \times k_{mod}$		$R_{5,k} \times k_{mod}$	
	Flange A	Flange B		4,0x40	4,0x60	4,0x40	4,0x60	CNA Connector nail		4,0x40	4,0x60
Nailing pattern 2	4	4	P	$f \leq 26:$ $\frac{54}{f+62,5}$	$f \leq 24:$ $\frac{76}{f+62,5}$	1,5	2,1	$e < 40:$ $\frac{28,5}{40-e}$	$e < 40:$ $\frac{40,6}{40-e}$	Min:  $\frac{21}{55-e}$	Min:  $\frac{30}{55-e}$
								$e \leq 26: 2,2$	$e \leq 27: 2,8$		
								$26 < e \leq 53:$ $\frac{54}{e}$	$27 < e \leq 48:$ $\frac{76}{e}$		
				$f > 26:$ $\frac{15,5}{f}$	$f > 24:$ $\frac{21}{f}$			$e > 53:$ $\frac{21}{e-35}$	$e > 48:$ $\frac{21}{e-35}$	$\frac{1,0 \cdot b + 10}{e}$	$\frac{1,5 \cdot b + 15}{e}$
Nailing pattern 1	4	6	P	$f \leq 16:$ $\frac{66}{f+62,5}$	$f \leq 15:$ $\frac{109}{f+62,5}$	1,5	2,2	$e < 40:$ $\frac{24,4}{40-e}$	$e < 40:$ $\frac{40,6}{40-e}$	Min:  $\frac{18}{55-e}$	Min:  $\frac{30}{55-e}$
								$e \leq 29: 2,2$	$e \leq 28: 2,8$		
								$29 < e \leq 52:$ $\frac{64}{e}$	$28 < e \leq 48:$ $\frac{79}{e}$		
				$f > 16:$ $\frac{13,3}{f}$	$f > 15:$ $\frac{21}{f}$			$e > 52:$ $\frac{21}{e-35}$	$e > 48:$ $\frac{21}{e-35}$	$\frac{1,6 \cdot b + 32}{e}$	$\frac{2,7 \cdot b + 53}{e}$

b, e and f are in mm.

When the purlin has a wane on the side towards the Angle Bracket with an extent from the bottom up to the lower nail the formula in the grey square shall be checked additionally.

Table D5-3 Modified characteristic capacity timber beam to timber beam – 1 Angle Bracket Load duration L

1 Angle Bracket ABR70 per connection			Modified characteristic capacity per connection (kN)								
Nailing pattern	Number of fasteners		Load duration	$R_{1,k} \times k_{mod}$		$R_{2/3,k} \times k_{mod}$		$R_{4,k} \times k_{mod}$		$R_{5,k} \times k_{mod}$	
	Flange A	Flange B		4,0x40	4,0x60	4,0x40	4,0x60	CNA Connector nail		4,0x40	4,0x60
								4,0x40	4,0x60		
Nailing pattern 2	4	4	L	$f \leq 26:$ $\frac{61}{f+62,5}$	$f \leq 19:$ $\frac{89}{f+62,5}$	1,7	2,4	$e < 40:$ $\frac{32,6}{40-e}$	$e < 40:$ $\frac{47,4}{40-e}$	Min:  $\frac{24}{55-e}$	Min:  $\frac{34}{55-e}$
								$e \leq 24: 2,6$ $24 < e \leq 49:$ $\frac{61}{e}$ $e > 49:$ $\frac{21}{e-35}$	$e \leq 24: 3,3$ $24 < e \leq 48:$ $\frac{79}{e}$ $e > 48:$ $\frac{21}{e-35}$		
Nailing pattern 1	4	6	L	$f \leq 16:$ $\frac{77}{f+62,5}$	$f \leq 12:$ $\frac{127}{f+62,5}$	1,7	2,6	$e < 40:$ $\frac{28,5}{40-e}$	$e < 40:$ $\frac{47,4}{40-e}$	Min:  $\frac{21}{55-e}$	Min:  $\frac{34}{55-e}$
								$e \leq 29: 2,6$ $29 < e \leq 49:$ $\frac{74}{e}$ $e > 49:$ $\frac{21}{e-35}$	$e \leq 24: 3,3$ $24 < e \leq 48:$ $\frac{79}{e}$ $e > 48:$ $\frac{21}{e-35}$		
				$f > 26:$ $\frac{17,8}{f}$	$f > 19:$ $\frac{21}{f}$					$1,2 \cdot b + 12$ $e$	$1,7 \cdot b + 17$ $e$
				$f > 16:$ $\frac{15,5}{f}$	$f > 12:$ $\frac{21}{f}$					$1,9 \cdot b + 37$ $e$	$3,1 \cdot b + 62$ $e$

b, e and f are in mm.

When the purlin has a wane on the side towards the Angle Bracket with an extent from the bottom up to the lower nail the formula in the grey square shall be checked additionally.

Table D5-4 Modified characteristic capacity timber beam to timber beam – 1 Angle Bracket Load duration M

1 Angle Bracket ABR70 per connection			Modified characteristic capacity per connection (kN)								
Nailing pattern	Number of fasteners		Load duration	$R_{1,k} \times k_{mod}$		$R_{2/3,k} \times k_{mod}$		$R_{4,k} \times k_{mod}$		$R_{5,k} \times k_{mod}$	
	Flange A	Flange B		4,0x40	4,0x60	4,0x40	4,0x60	CNA Connector nail		4,0x40	4,0x60
								4,0x40	4,0x60	4,0x40	4,0x60
Nailing pattern 2	4	4	M	$f \leq 26:$ $\frac{61}{f+62,5}$	$f \leq 16:$ $\frac{102}{f+62,5}$	1,9	2,7	$e < 40:$ $\frac{32,6}{40-e}$	$e < 40:$ $\frac{54,1}{40-e}$	Min: $\frac{24}{55-e}$	Min: $\frac{39}{55-e}$
								$e \leq 21: 2,9$	$e \leq 21: 3,8$	1,7	2,8
				$f > 26:$ $\frac{17,8}{f}$	$f > 16:$ $\frac{21}{f}$			$21 < e \leq 48:$ $\frac{61}{e}$	$21 < e \leq 48:$ $\frac{79}{e}$	$\frac{1,2 \cdot b + 12}{e}$	$\frac{2,0 \cdot b + 20}{e}$
Nailing pattern 1	4	6	M	$f \leq 16:$ $\frac{88}{f+62,5}$	$f \leq 11:$ $\frac{146}{f+62,5}$	2	2,9	$e < 40:$ $\frac{32,6}{40-e}$	$e < 40:$ $\frac{54,1}{40-e}$	Min: $\frac{24}{55-e}$	Min: $\frac{39}{55-e}$
								$e \leq 27: 2,9$	$e \leq 21: 3,8$	2	3,4
				$f > 16:$ $\frac{17,8}{f}$	$f > 11:$ $\frac{21}{f}$			$27 < e \leq 48:$ $\frac{79}{e}$	$21 < e \leq 48:$ $\frac{79}{e}$	$\frac{2,1 \cdot b + 43}{e}$	$\frac{3,5 \cdot b + 71}{e}$
								$e > 48:$ $\frac{21}{e-35}$	$e > 48:$ $\frac{21}{e-35}$		

b, e and f are in mm.

When the purlin has a wane on the side towards the Angle Bracket with an extent from the bottom up to the lower nail the formula in the gray square shall be checked additionally.

Table D5-5 Modified characteristic capacity timber beam to timber beam – 1 Angle Bracket Load duration S

1 Angle Bracket ABR70 per connection			Modified characteristic capacity per connection (kN)								
Nailing pattern	Number of fasteners		Load duration	$R_{1,k} \times k_{mod}$		$R_{2/3,k} \times k_{mod}$		$R_{4,k} \times k_{mod}$		$R_{5,k} \times k_{mod}$	
	Flange A	Flange B		4,0x40	4,0x60	4,0x40	4,0x60	CNA Connector nail		4,0x40	4,0x60
								4,0x40	4,0x60		
Nailing pattern 2	4	4	S	$f \leq 26:$ $\frac{69}{f+62,5}$	$f \leq 14:$ $\frac{115}{f+62,5}$	2,2	3,1	$e < 40:$ $\frac{36,6}{40-e}$	$e < 40:$ $\frac{60,9}{40-e}$	Min: $\frac{27}{55-e}$	Min: $\frac{44}{55-e}$
								$e \leq 21: 3,3$ $21 < e \leq 48:$ $\frac{69}{e}$ $e > 48:$ $\frac{21}{e-35}$	$e \leq 19: 4,2$ $19 < e \leq 48:$ $\frac{79}{e}$ $e > 48:$ $\frac{21}{e-35}$	1,9 $\frac{1,3 \cdot b + 13}{e}$	3,1 $\frac{2,2 \cdot b + 22}{e}$
Nailing pattern 1	4	6	S	$f \leq 16:$ $\frac{99}{f+62,5}$	$f \leq 9:$ $\frac{164}{f+62,5}$	2,2	3,3	$e < 40:$ $\frac{36,6}{40-e}$	$e < 40:$ $\frac{60,9}{40-e}$	Min: $\frac{27}{55-e}$	Min: $\frac{44}{55-e}$
								$e \leq 24: 3,3$ $24 < e \leq 48:$ $\frac{79}{e}$ $e > 48:$ $\frac{21}{e-35}$	$e \leq 19: 4,2$ $19 < e \leq 48:$ $\frac{79}{e}$ $e > 48:$ $\frac{21}{e-35}$	2,3 $\frac{2,4 \cdot b + 48}{e}$	3,8 $\frac{4,0 \cdot b + 80}{e}$

b, e and f are in mm.

■ When the purlin has a wane on the side towards the Angle Bracket with an extent from the bottom up to the lower nail the formula in the grey square shall be checked additionally.

Table D5-6 Modified characteristic capacity timber beam to timber beam – 1 Angle Bracket Load duration I

1 Angle Bracket ABR70 per connection			Modified characteristic capacity per connection (kN)								
Nailing pattern	Number of fasteners		Load duration	$R_{1,k} \times k_{mod}$		$R_{2/3,k} \times k_{mod}$		$R_{4,k} \times k_{mod}$		$R_{5,k} \times k_{mod}$	
	Flange A	Flange B		4,0x40		4,0x60		CNA Connector nail		4,0x40	4,0x60
Nailing pattern 2	4	4	I	$f \leq 21: \frac{84}{f+62,5}$ $f > 21: \frac{21}{f}$	$f \leq 11: \frac{139}{f+62,5}$ $f > 11: \frac{21}{f}$	2,7	3,8	$e < 40: \frac{44,8}{40-e}$	$e < 40: \frac{74,4}{40-e}$	Min: $\frac{33}{55-e}$	Min: $\frac{54}{55-e}$
								$e \leq 20: 4,0$	$e \leq 15: 5,2$		
Nailing pattern 1	4	6	I	$f \leq 13: \frac{120}{f+62,5}$ $f > 13: \frac{21}{f}$	$f \leq 7: \frac{199}{f+62,5}$ $f > 7: \frac{21}{f}$	2,7	4,0	$e < 40: \frac{44,8}{40-e}$	$e < 40: \frac{74,4}{40-e}$	Min: $\frac{33}{55-e}$	Min: $\frac{54}{55-e}$
								$e \leq 20: 4,0$	$e \leq 15: 5,2$		

b, e and f are in mm.

When the purlin has a wane on the side towards the Angle Bracket with an extent from the bottom up to the lower nail the formula in the grey square shall be checked additionally.

## Annex D6 – AB70

### Product Name:

Product Name	Material reference acc. to clause II-1	Alternative product names
AB70	Steel ref. 1	Germany: 70 o/R
AB70S	Steel ref. 2	-
AB70S2	Steel ref. 3	-

### Connector Size Range:

Model no.	Dimensions [mm]				Holes flange A		Holes flange B	
	A	B	C	Thickness	Ø5	Ø8,5	Ø5	Ø8,5
AB70	70	70	55	2,0	4	2	7	1

### Drawing:

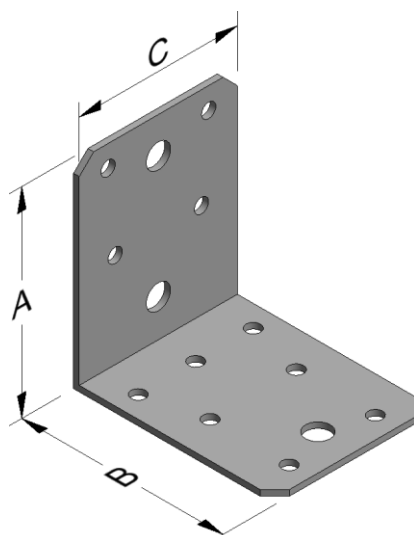

### Nailing pattern:

Nailing pattern 1

Nailing pattern 2

Flange A:

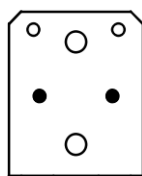
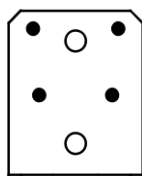

Flange B:

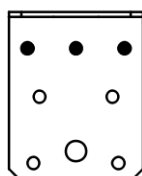
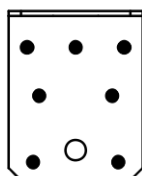

Beam to beam  
Maximum nailing

Beam to beam  
Minimum nailing



Table D6-1 Modified characteristic capacity timber beam to timber beam – 2 Angle Brackets

2 Angle Brackets AB70 per connection			Modified characteristic capacity per connection (kN)						
Nailing pattern	Number of fasteners		Load duration	$R_{1,k} \times k_{mod}$		$R_{2/3,k} \times k_{mod}$		$R_{4/5,k} \times k_{mod}$	
	Flange A	Flange B		CNA Connector nail					
			4,0x40	4,0x60	4,0x40	4,0x60	4,0x40	4,0x60	
Nailing pattern 2	2	3	P	2,7	4,0	2,3	3,4	$\frac{1,33 \cdot b + 26}{e-2}$ max 3,3	$\frac{1,98 \cdot b + 30}{e-2}$ max 3,5
			L	3,0	4,5	2,7	3,9	$\frac{1,50 \cdot b + 27}{e-2}$ max 3,8	$\frac{2,25 \cdot b + 32}{e-2}$ max 3,8
			M	3,3	4,7	3,1	4,5	$\frac{1,66 \cdot b + 28}{e-2}$ max 3,8	$\frac{2,34 \cdot b + 33}{e-2}$ max 4,0
			S	3,6	4,7	3,5	5,1	$\frac{1,82 \cdot b + 29}{e-2}$ max 4,3	$\frac{2,34 \cdot b + 33}{e-2}$ max 4,3
			I	4,3	4,7	4,2	6,2	$\frac{2,14 \cdot b + 31}{e-2}$ max 4,7	$\frac{2,34 \cdot b + 33}{e-2}$ max 4,7
Nailing pattern 1	4	7	P	2,7	4,0	3,2	4,5	$\frac{1,33 \cdot b + 26}{e-2}$ max 3,5	$\frac{1,98 \cdot b + 30}{e-2}$ max 3,5
				2,5	3,8				
			L	2,9	4,5	3,8	5,3	$\frac{1,45 \cdot b + 26}{e-2}$ max 3,8	$\frac{2,25 \cdot b + 32}{e-2}$ max 3,8
				2,8	4,2				
			M	3,3	4,7	4,3	6,0	$\frac{1,66 \cdot b + 28}{e-2}$ max 4,0	$\frac{2,34 \cdot b + 33}{e-2}$ max 4,0
				3,2	4,2				
			S	3,6	4,7	4,9	6,8	$\frac{1,82 \cdot b + 29}{e-2}$ max 4,3	$\frac{2,34 \cdot b + 33}{e-2}$ max 4,3
				3,5	4,2				
			I	4,2	4,7	5,9	8,3	$\frac{2,07 \cdot b + 31}{e-2}$ max 4,7	$\frac{2,34 \cdot b + 33}{e-2}$ max 4,7
				4,0	4,2				

b and e are in mm.

■ When the purlin has a wane on the side towards the Angle Bracket with an extent from the bottom up to the lower nail the value in the grey square shall be checked additionally.

## Annex D7 – E20/3

### Product Name:

Product Name	Material reference acc. to clause II-1	Alternative product names
E20/3	Steel ref. 1	-
E20/3S	Steel ref. 2	-
E20/3S2	Steel ref. 3	-

### Connector Size Range:

Model no.	Dimensions [mm]				Holes flange A		Holes flange B	
	A	B	C	Thickness	Ø5	Ø11	Ø5	Ø11
E20/3	170	113	95	3,0	24	5	16	4

### Drawing:

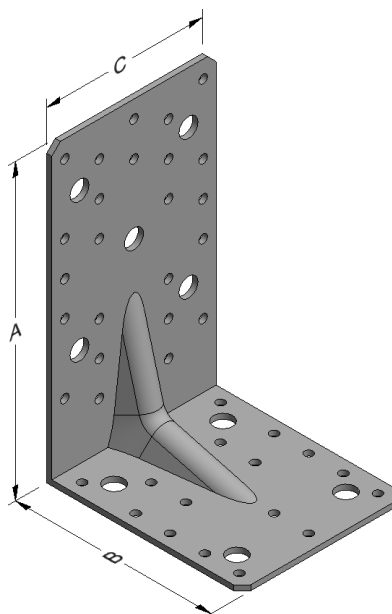

**Nailing pattern:**

Nailing pattern 1

Nailing pattern 2

Nailing pattern 3

Nailing pattern 4

Flange A:

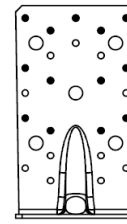
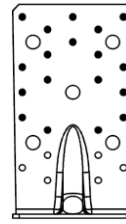
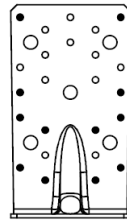
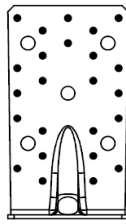

Flange B:

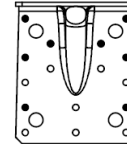
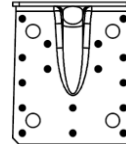
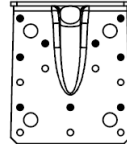
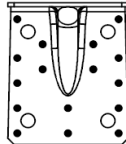

Beam to beam  
Maximum nailing

Beam to beam  
Minimum nailing

Trimmer connection

Column (A) to  
beam (B)

Nailing pattern 5

Nailing pattern 6

Flange A:

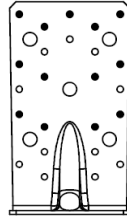
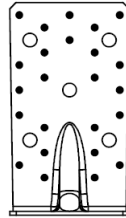

Flange B:

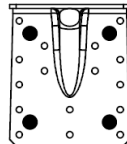
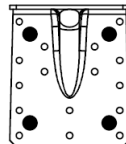

Beam (A) to rigid  
support (B)

Column (A) to rigid  
support (B)

Table D7-1 Modified characteristic capacity timber beam to timber beam – 2 Angle Brackets

2 Angle Brackets E20/3 per connection			Modified characteristic capacity per connection (kN)					
Nailing pattern	Number of fasteners		Load duration	R <sub>1,k</sub> x k <sub>mod</sub>		R <sub>2/3,k</sub> x k <sub>mod</sub>		
	Flange A	Flange B		CNA Connector nail				
			4,0x35	4,0x50	4,0x35	4,0x50		
Nailing pattern 2	12	9	P	3,3	5,3	9,0	12,1	
			L	3,9	6,2	10,5	14,2	
			M	4,4	7,1	12,0	16,2	
			S	5,0	7,9	13,5	18,2	
			I	6,1	9,7	16,5	22,2	
Nailing pattern 1	24	16	P	4,4	7,1	11,9	15,9	
				3,2	5,2			
			L	5,1	8,2	13,9	18,6	
				3,8	6,1			
			M	5,9	9,4	15,9	21,2	
				4,3	7,0			
			S	6,6	10,6	17,9	23,9	
				4,9	7,8			
			I	8,1	12,9	21,8	29,2	
				6,0	9,6			

b and e are in mm.

■ When the purlin has a wane on the side towards the Angle Bracket with an extent from the bottom up to the lower nail the value in the gray square is valid.

Table D7-2 Modified characteristic capacity timber beam to timber beam – 1 Angle Bracket

1 Angle Brackets E20/3 per connection			Modified characteristic capacity per connection (kN)				
Nailing pattern	Number of fasteners		Load duration	$R_{1,k} \times k_{mod}$		$R_{2/3,k} \times k_{mod}$	
	Flange A	Flange B		CNA Connector nail			
			4,0x35	4,0x50	4,0x35	4,0x50	
Nailing pattern 2	12	9	P	$f \leq 58$ : $\frac{119}{f+73}$	$f \leq 80$ : $\frac{162}{f+73}$	4,5	6,1
				$f > 58$ : $\frac{53}{f}$	$f > 80$ : $\frac{85}{f}$		
			L	$f \leq 65$ : $\frac{131}{f+73}$	$f \leq 88$ : $\frac{181}{f+73}$	5,3	7,1
				$f > 65$ : $\frac{62}{f}$	$f > 88$ : $\frac{99}{f}$		
			M	$f \leq 71$ : $\frac{143}{f+73}$	$f \leq 94$ : $\frac{200}{f+73}$	6,0	8,1
	$f > 71$ : $\frac{71}{f}$	$f > 94$ : $\frac{113}{f}$					
S	$f \leq 77$ : $\frac{155}{f+73}$	$f \leq 101$ : $\frac{219}{f+73}$	6,8	9,1			
	$f > 77$ : $\frac{79}{f}$	$f > 101$ : $\frac{127}{f}$					
I	$f \leq 87$ : $\frac{179}{f+73}$	$f \leq 112$ : $\frac{257}{f+73}$	8,3	11,1			
	$f > 87$ : $\frac{97}{f}$	$f > 112$ : $\frac{155}{f}$					

f are in mm.

Wane may not occur under the angle bracket.

Table D7-3 Modified characteristic capacity timber beam to timber beam – 1 Angle Bracket

1 Angle Brackets E20/3 per connection			Modified characteristic capacity per connection (kN)				
Nailing pattern	Number of fasteners		Load duration	$R_{1,k} \times k_{mod}$		$R_{2/3,k} \times k_{mod}$	
	Flange A	Flange B		CNA Connector nail			
			4,0x35	4,0x50	4,0x35	4,0x50	
Nailing pattern 1	24	16	P	$f \leq 58$ : <u>119</u> f+73	$f \leq 80$ : <u>162</u> f+73	6,0	8,0
				$f > 58$ : <u>53</u> f	$f > 80$ : <u>85</u> f		
			L	$f \leq 65$ : <u>131</u> f+73	$f \leq 90$ : <u>181</u> f+73	6,9	9,3
				$f > 65$ : <u>62</u> f	$f > 90$ : <u>99</u> f		
			M	$f \leq 71$ : <u>143</u> f+73	$f \leq 95$ : <u>200</u> f+73	7,9	10,6
$f > 71$ : <u>71</u> f	$f > 95$ : <u>113</u> f						
S	$f \leq 77$ : <u>155</u> f+73	$f \leq 101$ : <u>219</u> f+73	8,9	11,9			
	$f > 77$ : <u>79</u> f	$f > 101$ : <u>127</u> f					
I	$f \leq 87$ : <u>179</u> f+73	$f \leq 112$ : <u>257</u> f+73	10,9	14,6			
	$f > 87$ : <u>97</u> f	$f > 112$ : <u>155</u> f					

f are in mm.

Wane may not occur under the angle bracket.

Table D7-4 Modified characteristic capacity timber column to timber beam – 2 Angle Brackets

2 Angle Brackets E20/3 per connection			Modified characteristic capacity per connection (kN)					
Nailing pattern	Number of fasteners		Load duration	$R_{1,k} \times k_{mod}$		$R_{2/3,k} \times k_{mod}$		
	Flange A	Flange B		CNA Connector nail				
			4,0x35	4,0x50	4,0x35	4,0x50		
Nailing pattern 4	13	8	P	3,3	5,3	7,1	9,5	
			L	3,9	6,2	8,2	11,1	
			M	4,4	7,1	9,4	12,7	
			S	5,0	7,9	10,6	14,3	
			I	6,1	9,7	12,9	17,5	

Table D7-5 Modified characteristic capacity timber beam to rigid support – 2 Angle Brackets

2 Angle Brackets E20/3 per connection			Modified characteristic capacity per connection (kN)					
Nailing pattern	Number of fasteners		Load duration	$R_{1,k} \times k_{mod}$		$R_{2/3,k} \times k_{mod}$		
	Flange A	Flange B		CNA Connector nail				
			4,0x35	4,0x50	4,0x35	4,0x50		
Nailing pattern 5	24	4 Bolts	P	32,2	42,6	23,4	26,8	
				22,0	33,6			
			L	37,5	49,7	27,3	31,3	
				25,6	39,2			
			M	42,9	56,8	31,2	35,8	
				29,3	44,8			
			S	48,3	63,9	35,1	40,2	
				33,0	50,4			
			I	59,0	78,1	42,9	49,2	
				40,3	61,6			

■ When the purlin has a wane on the side towards the Angle Bracket with an extent from the bottom up to the lower nail the value in the grey square is valid.

Requirement for bolts - see declaration under table D7-6.

Table D7-6 Modified characteristic capacity timber beam to rigid support – 1 Angle Bracket

1 Angle Brackets E20/3 per connection			Modified characteristic capacity per connection (kN)				
Nailing pattern	Number of fasteners		Load duration	R <sub>1,k</sub> x k <sub>mod</sub>		R <sub>2/3,k</sub> x k <sub>mod</sub>	
	Flange A	Flange B		CNA Connector nail			
			4,0x35	4,0x50	4,0x35	4,0x50	
Nailing pattern 5	24	4 Bolts	P	f ≤ 4: $\frac{336}{f+19,1}$	f ≤ 6: $\frac{336}{f+19,1}$	11,7	14,2
				f > 4: $\frac{53}{f}$	f > 6: $\frac{85}{f}$		
			L	f ≤ 4: $\frac{336}{f+19,1}$	f ≤ 8: $\frac{336}{f+19,1}$	13,7	16,5
				f > 4: $\frac{62}{f}$	f > 8: $\frac{99}{f}$		
			M	f ≤ 5: $\frac{336}{f+19,1}$	f ≤ 10: $\frac{336}{f+19,1}$	15,6	18,9
	f > 5: $\frac{71}{f}$	f > 10: $\frac{113}{f}$					
S	f ≤ 6: $\frac{336}{f+19,1}$	f ≤ 12: $\frac{336}{f+19,1}$	17,6	21,3			
	f > 6: $\frac{79}{f}$	f > 12: $\frac{127}{f}$					
I	f ≤ 8: $\frac{336}{f+19,1}$	f ≤ 16: $\frac{336}{f+19,1}$	21,5	26,0			
	f > 8: $\frac{97}{f}$	f > 16: $\frac{155}{f}$					

f are in mm.

Force direction F<sub>1</sub>: the two bolts in the first row, next to the bending line, shall have a capacity to sustain an axial force of 1,1 x F<sub>1,d</sub>.

Force direction F<sub>2</sub>: the bolt group shall have a capacity to sustain the followings:

F<sub>2,d</sub>; M<sub>X,F2</sub>=F<sub>2,d</sub> x 59mm ; M<sub>Y,F2</sub>=F<sub>2,d</sub> x 89mm see picture

The force F<sub>2</sub> must be applied to each E20/3. So for a connection with two E20/3, the bolt group for one angle bracket has to be calculated for F<sub>2</sub>/2, same for force direction F<sub>1</sub>.

Wane may not occur under the angle brackets.

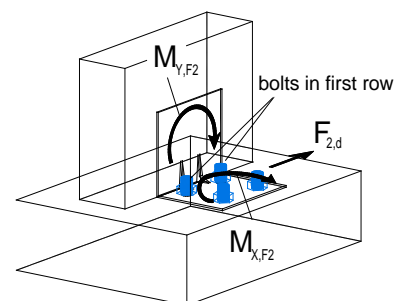



**Table D7-7** Modified characteristic capacity timber column to rigid support – 2 Angle Brackets

1 Angle Bracket E20/3 per connection				Modified characteristic capacities per connection (kN)			
				$R_{1,k} \times k_{mod}$		$R_{2/3,k} \times k_{mod}$	
Nailing pattern	Number of fasteners		Load duration	CNA4,0x35	CNA4,0x50	CNA4,0x35	CNA4,0x50
	Flange A	Flange B					
Nailing pattern 6	13	4 bolts	P	18,1	24,0	15,3	17,5
			L	21,1	28,0	17,8	20,4
			M	24,1	32,0	20,4	23,3
			S	27,2	36,0	22,9	26,2
			I	33,2	44,0	28,0	32,0

Wane may not occur under the angle bracket.

**Table D7-8** Modified characteristic capacity timber to timber – trimmer connection

1 or 2 Angle Bracket(-s) E20/3 per connection				Modified characteristic capacity per connection (kN)			
				2 Angle Brackets E20/3 per connection		1 Angle Bracket E20/3 per connection	
				$R_{2/3,k} \times k_{mod}$		$R_{2/3,k} \times k_{mod}$	
Nailing pattern	Number of fasteners		Load duration	CNA4,0x35	CNA4,0x50	CNA4,0x35	CNA4,0x50
	Flange A	Flange B					
Nailing pattern 3	18	16	P	7,6	11,6	3,8	5,8
			L	8,9	13,5	4,4	6,7
			M	10,1	15,4	5,1	7,7
			S	11,4	17,4	5,7	8,7
			I	13,9	21,2	7,0	10,6

Wane may not occur under the angle brackets.

<sup>1)</sup> The capacities are based on the assumption that the bolts have a characteristic lateral capacity of 20 kN and a characteristic axial capacity of 22 kN. If one of the characteristic capacities of the chosen bolts is smaller, the capacity of the connection shall be reduced proportionally.

## Annex D8 – E9/2.5

### Product Name:

Product Name	Material reference acc. to clause II-1	Alternative product names
E9/2.5	Steel ref. 1	-
E9/2.5S	Steel ref. 2	-
E9/2.5S2	Steel ref. 3	-

### Connector Size Range:

Model no.	Dimensions [mm]				Holes flange A		Holes flange B	
	A	B	C	Thickness	Ø5	Ø11	Ø5	Ø11
E9/2.5	154	152,5	65	2,5	14	2	14	2

### Drawing:

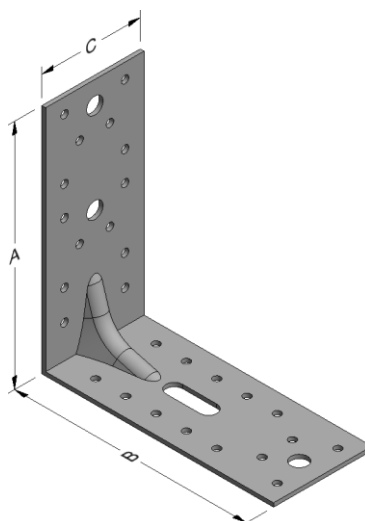

### Nailing pattern:

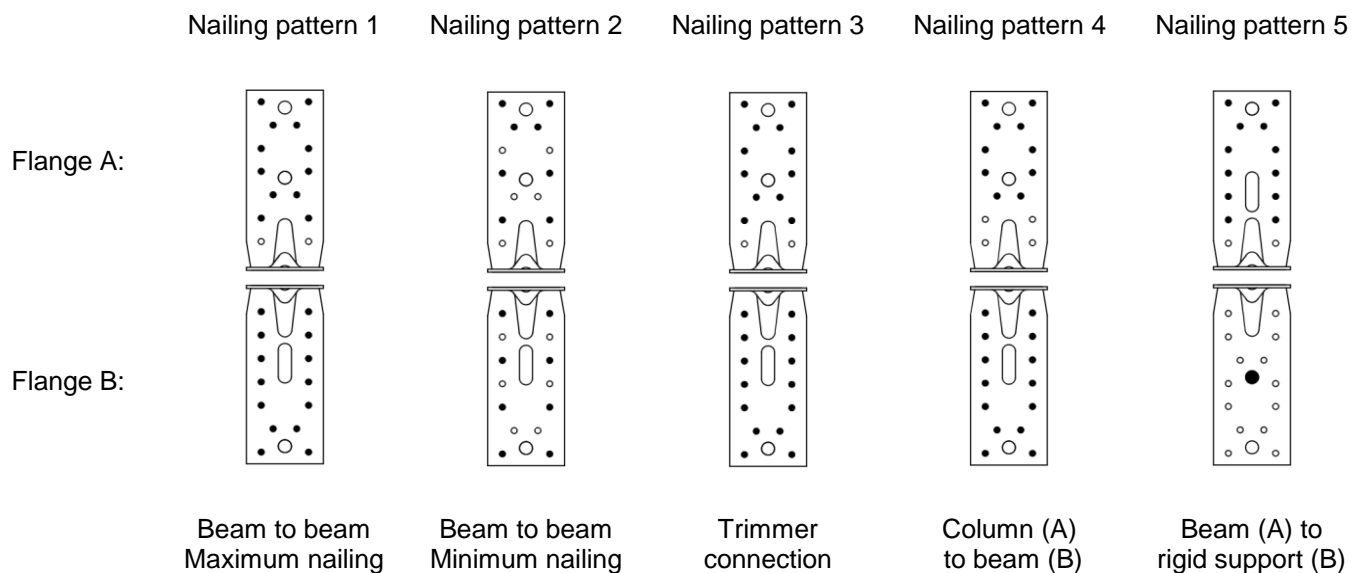

Table D8-1 Modified characteristic capacity timber beam to timber beam – 2 Angle Brackets

2 Angle Brackets E9/2.5 per connection			Modified characteristic capacity per connection (kN)				
Nailing pattern	Number of fasteners		Load duration	$R_{1,k} \times k_{mod}$		$R_{2/3,k} \times k_{mod}$	
	Flange A	Flange B		CNA Connector nail			
				4,0x35	4,0x50	4,0x35	4,0x50
Nailing pattern 2	8	8	P	1,1	1,9	4,0	5,3
				1,0	1,6		
			L	1,3	2,3	4,6	6,2
				1,1	1,8		
			M	1,5	2,6	5,3	7,1
				1,3	2,1		
			S	1,7	3,0	5,9	8,0
				1,5	2,3		
			I	2,2	3,9	7,2	9,7
				1,8	2,9		
Nailing pattern 1	12	14	P	2,9	4,8	5,7	7,8
				2,2	3,6		
			L	3,4	5,7	6,6	9,1
				2,6	4,2		
			M	3,9	6,7	7,6	10,4
				3,0	4,8		
			S	4,5	7,6	8,5	11,7
				3,4	5,4		
			I	5,6	9,5	10,4	14,3
				4,1	6,6		

■ When the purlin has a wane on the side towards the Angle Bracket with an extent from the bottom up to the lower nail the value in the grey square is valid.

Table D8-2 Modified characteristic capacity timber beam to timber beam – 1 Angle Bracket

1 Angle Brackets E9/2.5 per connection			Modified characteristic capacity per connection (kN)				
Nailing pattern	Number of fasteners		Load duration	R <sub>1,k</sub> x k <sub>mod</sub>		R <sub>2/3,k</sub> x k <sub>mod</sub>	
	Flange A	Flange B		CNA Connector nail			
				4,0x35	4,0x50	4,0x35	4,0x50
Nailing pattern 2	8	8	P	f <sub>≤24</sub> : <u>45</u> f+62,5	f <sub>≤31</sub> : <u>60</u> f+62,5	2,0	2,7
				f <sub>&gt;24</sub> : <u>12</u> f	f <sub>&gt;31</sub> : <u>20</u> f		
			L	f <sub>≤26</sub> : <u>49</u> f+62,5	f <sub>≤27</sub> : <u>67</u> f+62,5	2,3	3,1
				f <sub>&gt;26</sub> : <u>15</u> f	f <sub>&gt;27</sub> : <u>20</u> f		
			M	f <sub>≤28</sub> : <u>53</u> f+62,5	f <sub>≤24</sub> : <u>74</u> f+62,5	2,6	3,5
	f <sub>&gt;28</sub> : <u>17</u> f	f <sub>&gt;24</sub> : <u>20</u> f					
S	f <sub>≤30</sub> : <u>58</u> f+62,5	f <sub>≤21</sub> : <u>80</u> f+62,5	3,0	4,0			
	f <sub>&gt;30</sub> : <u>19</u> f	f <sub>&gt;21</sub> : <u>20</u> f					
I	f <sub>≤28</sub> : <u>66</u> f+62,5	f <sub>≤17</sub> : <u>94</u> f+62,5	3,6	4,9			
	f <sub>&gt;28</sub> : <u>20</u> f	f <sub>&gt;17</sub> : <u>20</u> f					

f are in mm.

Wane may not occur under the angle bracket.

Table D8-3 Modified characteristic capacity timber beam to timber beam – 1 Angle Bracket

1 Angle Brackets E9/2.5 per connection			Modified characteristic capacity per connection (kN)				
Nailing pattern	Number of fasteners		Load duration	$R_{1,k} \times k_{mod}$		$R_{2/3,k} \times k_{mod}$	
	Flange A	Flange B		CNA Connector nail			
			4,0x35	4,0x50	4,0x35	4,0x50	
Nailing pattern 1	12	14	P	$f \leq 25$ : <u>35</u> $f+44$	$f \leq 38$ : <u>43</u> $f+44$	2,8	3,9
				$f > 25$ : <u>12</u> f	$f > 38$ : <u>20</u> f		
			L	$f \leq 29$ : <u>37</u> $f+44$	$f \leq 33$ : <u>47</u> $f+44$	3,3	4,5
				$f > 29$ : <u>15</u> f	$f > 33$ : <u>20</u> f		
			M	$f \leq 32$ : <u>39</u> $f+44$	$f \leq 29$ : <u>51</u> $f+44$	3,8	5,2
$f > 32$ : <u>17</u> f	$f > 29$ : <u>20</u> f						
S	$f \leq 35$ : <u>42</u> $f+44$	$f \leq 26$ : <u>55</u> $f+44$	4,3	5,8			
$f > 35$ : <u>19</u> f	$f > 26$ : <u>20</u> f						
I	$f \leq 34$ : <u>47</u> $f+44$	$f \leq 21$ : <u>62</u> $f+44$	5,2	7,1			
$f > 34$ : <u>20</u> f	$f > 21$ : <u>20</u> f						

f are in mm.

Wane may not occur under the angle bracket.

**Table D8-4** Modified characteristic capacity timber column to timber beam – 1 Angle Bracket

2 Angle Brackets E9/2.5 per connection				Modified characteristic capacity per connection (kN)			
				$R_{1,k} \times k_{mod}$		$R_{2,k} \times k_{mod}$	
Nailing pattern	Number of fasteners		Load duration	CNA4,0x35	CNA4,0x50	CNA4,0x35	CNA4,0x50
	Flange A (column)	Flange B (beam)					
Nailing pattern 4	10	14	P	1,8	3,0	3,3	5,1
			L	2,1	3,5	3,9	6,0
			M	2,4	4,1	4,4	6,8
			S	2,8	4,7	5,0	7,7
			I	3,5	5,9	6,1	9,4

**Table D8-5** Modified characteristic capacity trimmer connection

1 or 2 Angle Bracket(s) E9/2.5 per connection				Modified characteristic capacity per connection (kN)			
				2 Angle Brackets E9/2.5 per connection		1 Angle Bracket E9/2.5 per connection	
				$R_{2/3,k} \times k_{mod}$		$R_{2/3,k} \times k_{mod}$	
Nailing pattern	Number of fasteners		Load duration	CNA4,0x35	CNA4,0x50	CNA4,0x35	CNA4,0x50
	Flange A	Flange B					
Nailing pattern 3	12	14	P	5,7	7,8	2,8	3,9
			L	6,6	9,1	3,3	4,5
			M	7,6	10,4	3,8	5,2
			S	8,5	11,7	4,3	5,8
			I	10,4	14,3	5,2	7,1

**Table D8-6** Characteristic capacity timber beam to rigid support – 2 Angle Brackets

2 Angle Brackets E9/2.5 per connection			Characteristic capacities per connection (kN)
			$R_{1,k}$
Nailing pattern	Number of fasteners		CNA4,0x35
	Flange A	Flange B	
Nailing pattern 5	12	1 Bolt	6,0

The bolt group must be able to resist to  $R_{1,tension\ of\ bolt,d} = F_{1,d} \times 2,7$

## Annex D9 – E9S/2.5

### Product Name:

Product Name	Material reference acc. to clause II-1	Alternative product names
E9S/2.5	Steel ref. 1	-
E9S/2.5S	Steel ref. 2	-
E9S/2.5S2	Steel ref. 3	-

### Connector Size Range:

Model no.	Dimensions [mm]				Holes flange A		Holes flange B	
	A	B	C	Thickness s	Ø5	Ø11	Ø5	Ø11
E9S/2.5	94	152,5	65	2,5	8	1	14	2

### Drawing:

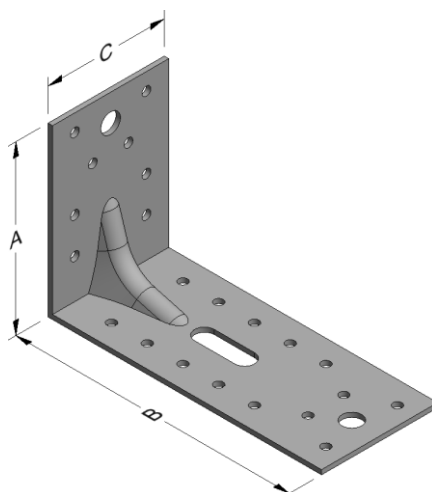

### Nailing pattern:

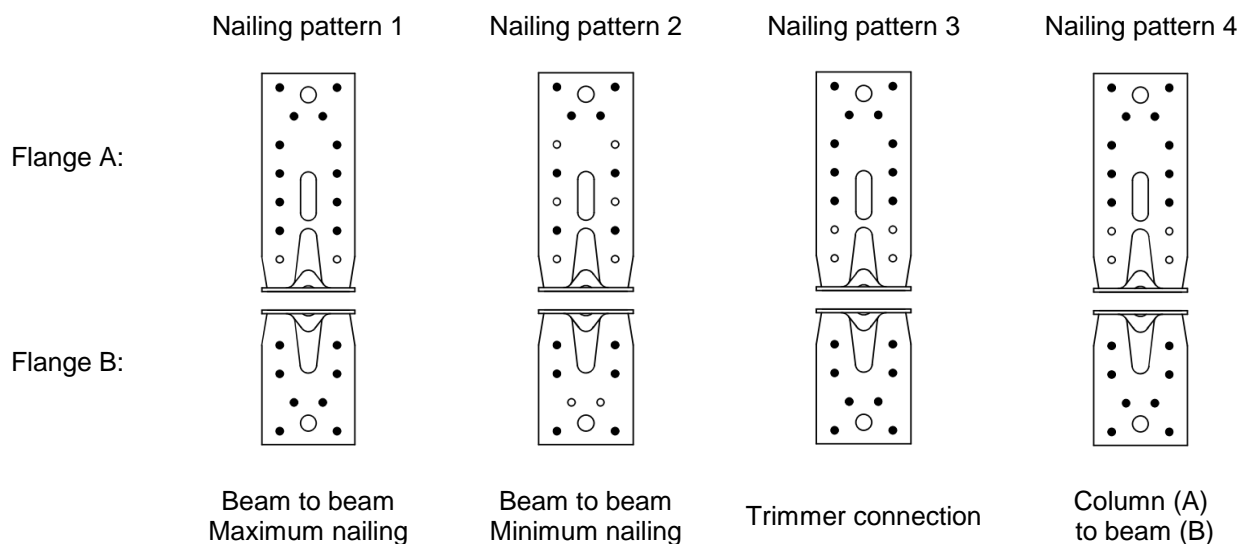

Table D9-1 Modified characteristic capacity timber beam to timber beam – 2 Angle Brackets

2 Angle Brackets E9S/2.5 per connection			Modified characteristic capacity per connection (kN)				
Nailing pattern	Number of fasteners		Load duration	$R_{1,k} \times k_{mod}$		$R_{2/3,k} \times k_{mod}$	
	Flange A	Flange B		CNA Connector nail			
				4,0x35	4,0x50	4,0x35	4,0x50
Nailing pattern 2	8	6	P	1,0	1,7	4,1	5,2
				0,6	1,0		
			L	1,2	2,1	4,8	6,1
				0,8	1,2		
			M	1,4	2,4	5,4	7,0
				0,9	1,4		
			S	1,6	2,8	6,1	7,9
				1,0	1,6		
			I	2,0	3,5	7,5	9,6
				1,2	1,9		
Nailing pattern 1	12	8	P	2,7	4,5	5,3	7,1
				2,1	3,4		
			L	3,2	5,4	6,2	8,3
				2,5	4,0		
			M	3,7	6,2	7,0	9,5
				2,9	4,6		
			S	4,2	7,1	7,9	10,7
				3,2	5,2		
			I	5,3	8,9	9,7	13,0
				3,9	6,3		

■ When the purlin has a wane on the side towards the Angle Bracket with an extent from the bottom up to the lower nail the value in the grey square is valid.



Table D9-2 Modified characteristic capacity timber beam to timber beam – 1 Angle Bracket

1 Angle Bracket E9S/2.5 per connection			Modified characteristic capacity per connection (kN)				
Nailing pattern	Number of fasteners		Load duration	$R_{1,k} \times k_{mod}$		$R_{2/3,k} \times k_{mod}$	
	Flange A	Flange B		CNA Connector nail			
				4,0x35	4,0x50	4,0x35	4,0x50
Nailing pattern 2	8	6	P	$f \leq 28$ : <u>83</u> f+84	$f \leq 17$ : <u>120</u> f+84	2,0	2,6
				$f > 28$ : <u>20</u> f	$f > 17$ : <u>20</u> f		
			L	$f \leq 24$ : <u>93</u> f+84	$f \leq 15$ : <u>137</u> f+84	2,4	3,1
				$f > 24$ : <u>20</u> f	$f > 15$ : <u>20</u> f		
			M	$f \leq 21$ : <u>103</u> f+84	$f \leq 13$ : <u>154</u> f+84	2,7	3,5
$f > 21$ : <u>20</u> f	$f > 13$ : <u>20</u> f						
S	$f \leq 18$ : <u>114</u> f+84	$f \leq 11$ : <u>170</u> f+84	3,1	3,9			
$f > 18$ : <u>20</u> f	$f > 11$ : <u>20</u> f						
I	$f \leq 15$ : <u>134</u> f+84	$f \leq 9$ : <u>204</u> f+84	3,7	4,8			
$f > 15$ : <u>20</u> f	$f > 9$ : <u>20</u> f						

f are in mm.

Wane may not occur under the angle bracket.

Table D9-3 Modified characteristic capacity timber beam to timber beam – 1 Angle Bracket

1 Angle Bracket E9S/2.5 per connection			Modified characteristic capacity per connection (kN)				
Nailing pattern	Number of fasteners		Load duration	$R_{1,k} \times k_{mod}$		$R_{2/3,k} \times k_{mod}$	
	Flange A	Flange B		CNA Connector nail			
			4,0x35	4,0x50	4,0x35	4,0x50	
Nailing pattern 1	12	8	P	$f \leq 27$ : <u>33</u> f+44	$f \leq 43$ : <u>40</u> f+44	2,6	3,6
				$f > 27$ : <u>12</u> f	$f > 43$ : <u>20</u> f		
			L	$f \leq 32$ : <u>35</u> f+44	$f \leq 38$ : <u>44</u> f+44	3,1	4,2
				$f > 32$ : <u>15</u> f	$f > 38$ : <u>20</u> f		
			M	$f \leq 36$ : <u>37</u> f+44	$f \leq 34$ : <u>47</u> f+44	3,5	4,7
$f > 36$ : <u>17</u> f	$f > 34$ : <u>20</u> f						
S	$f \leq 41$ : <u>39</u> f+44	$f \leq 30$ : <u>50</u> f+44	4,0	5,3			
$f > 41$ : <u>19</u> f	$f > 30$ : <u>20</u> f						
I	$f \leq 39$ : <u>43</u> f+44	$f \leq 25$ : <u>57</u> f+44	4,8	6,5			
$f > 39$ : <u>20</u> f	$f > 25$ : <u>20</u> f						

f are in mm.

Wane may not occur under the angle bracket.

**Table D9-4** Modified characteristic capacity timber column to timber beam – 1 Angle Bracket

2 Angle Brackets E9S/2.5 per connection				Modified characteristic capacity per connection (kN)			
				$R_{1,k} \times k_{mod}$		$R_{2,k} \times k_{mod}$	
Nailing pattern	Number of fasteners		Load duration	CNA4,0x35	CNA4,0x50	CNA4,0x35	CNA4,0x50
	Flange A (beam)	Flange B (column)					
Nailing pattern 4	8	10	P	1,7	2,8	4,2	5,8
			L	2,0	3,3	4,9	6,8
			M	2,3	3,9	5,6	7,7
			S	2,6	4,4	6,3	8,7
			I	3,3	5,5	7,7	10,6

**Table D9-5** Modified characteristic capacity trimmer connection

1 or 2 Angle Bracket(-s) E9S/2.5 per connection				Modified characteristic capacity per connection (kN)			
				2 Angle Brackets E9S/2.5 per connection		1 Angle Bracket E9S/2.5 per connection	
				$R_{2/3,k} \times k_{mod}$		$R_{2/3,k} \times k_{mod}$	
Nailing pattern	Number of fasteners		Load duration	CNA4,0x35	CNA4,0x50	CNA4,0x35	CNA4,0x50
	Flange A	Flange B					
Nailing pattern 3	8	10	P	4,1	5,2	2,0	2,6
			L	4,8	6,1	2,4	3,1
			M	5,4	7,0	2,7	3,5
			S	6,1	7,9	3,1	3,9
			I	7,5	9,6	3,7	4,8

## Annex D10 – ABR9015

### Product Name:

Product Name	Material reference acc. to clause II-1	Alternative product names
ABR9015	Steel ref. 1	-
ABR9015S	Steel ref. 2	-
ABR9015S2	Steel ref. 3	-

### Connector Size Range:

Model no.	Dimensions [mm]				Holes flange A		Holes flange B	
	A	B	C	Thickness	Ø5	Ø13	Ø5	Ø13
ABR9015	89	89	60	1,5	10	1	10	1

### Drawing:

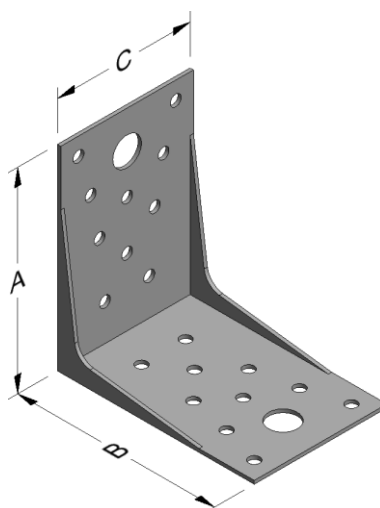

### Nailing pattern:

Nailing pattern 1

Nailing pattern 2

Flange A:

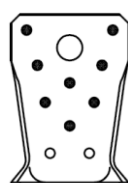
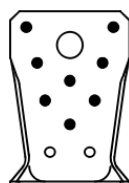

Flange B:

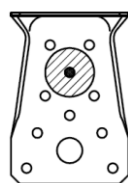

Beam to beam  
Maximum nailing

Beam to concrete

Table D10-1 Modified characteristic capacity timber beam to timber beam – 2 Angle Brackets

2 Angle Bracket ABR9015 per connection			Modified characteristic capacity per connection (kN)			
Nailing pattern	Number of fasteners		Load duration	$R_{1,k} \times k_{mod}$	$R_{2/3,k} \times k_{mod}$	$R_{4/5,k} \times k_{mod}$
	Flange A	Flange B		CSA Connector screw 5,0x40		
Nailing pattern 1	8	10	P	8,0	6,3	$\frac{4,1 \cdot b + 210}{e}$ max 19,4
			L	9,3	7,3	$\frac{4,5 \cdot b + 215}{e}$ max 22,6
			M	10,6	8,4	$\frac{4,9 \cdot b + 219}{e}$ max 25,7
			S	11,8	9,4	$\frac{5,3 \cdot b + 224}{e}$ max 28,8
			I	14,4	11,5	$\frac{6,2 \cdot b + 227}{e}$ max 35,1

Wane may occur under the angle brackets.

Table D10-2 Modified characteristic capacity timber beam to timber beam – 1 Angle Bracket

1 Angle Bracket ABR9015 per connection			Modified characteristic capacity per connection (kN)						
Nailing pattern	Number of fasteners		Load duration	$R_{1,k} \times k_{mod}$	$R_{2/3,k} \times k_{mod}$	$R_{4,k} \times k_{mod}$	$R_{5,k} \times k_{mod}$		
	Flange A	Flange B		CSA Connector screw 5,0x40					
Nailing pattern 1	8	10	P	$f \leq 29:$ $\frac{93,1}{f+32}$	3,1	$e \leq 7:$ 10,8	$e \leq 49:$ $\frac{110}{63-e}$		
				$f > 29:$ $\frac{44,6}{f}$		$7 < e \leq 85:$ $\frac{71,3}{e}$	$49 < e \leq 0,54 \cdot b + 32:$ 7,6		
						$e > 85:$ $\frac{44,6}{e-32}$	$e > 0,54 \cdot b + 32:$ $\frac{4,1 \cdot b - 233}{e-63}$		
				L		$f \leq 25:$ $\frac{101,2}{f+32}$	3,7	$e \leq 6:$ 12,9	$e \leq 48:$ $\frac{128}{63-e}$
						$f > 25:$ $\frac{44,6}{f}$		$6 < e \leq 85:$ $\frac{71,3}{e}$	$48 < e \leq 0,52 \cdot b + 33:$ 8,7
								$e > 85:$ $\frac{44,6}{e-32}$	$e > 0,52 \cdot b + 33:$ $\frac{4,5 \cdot b - 264}{e-63}$
			M		$f \leq 20:$ $\frac{109,3}{f+32}$	4,2		$e \leq 5:$ 14,4	$e \leq 48:$ $\frac{146}{63-e}$
					$f > 20:$ $\frac{44,6}{f}$			$5 < e \leq 85:$ $\frac{71,3}{e}$	$48 < e \leq 0,50 \cdot b + 33:$ 9,9
								$e > 85:$ $\frac{44,6}{e-32}$	$e > 0,50 \cdot b + 33:$ $\frac{4,9 \cdot b - 295}{e-63}$
				S	$f \leq 14:$ $\frac{117,4}{f+32}$		4,7	$e \leq 4:$ 16,2	$e \leq 48:$ $\frac{164}{63-e}$
					$14 < e \leq 23:$ $\frac{71,3}{f+14}$			$4 < e \leq 85:$ $\frac{71,3}{e}$	$48 < e \leq 0,48 \cdot b + 33:$ 11
					$f > 23:$ $\frac{71,3}{f}$			$e > 85:$ $\frac{44,6}{e-32}$	$e > 0,48 \cdot b + 33:$ $\frac{5,3 \cdot b - 326}{e-63}$
			I		$f \leq 7:$ $\frac{133,6}{f+32}$	5,7		$e \leq 4:$ 19,8	$e \leq 48:$ $\frac{201}{63-e}$
					$7 < e \leq 23:$ $\frac{71,3}{f+14}$			$4 < e \leq 85:$ $\frac{71,3}{e}$	$48 < e \leq 0,46 \cdot b + 34:$ 13,3
					$f > 23:$ $\frac{44,6}{f}$			$e > 85:$ $\frac{44,6}{e-32}$	$e > 0,46 \cdot b + 34:$ $\frac{6,2 \cdot b - 388}{e-63}$

f is in mm.

Wane may occur under the angle bracket.

Table D10-3 Modified characteristic capacity timber beam to timber beam – 2 Angle Bracket

2 Angle Bracket ABR9015 per connection			Modified characteristic capacity per connection (kN)									
Nailing pattern	Number of fasteners		Load duration	$R_{1,k} \times k_{mod}$				$R_{2/3,k} \times k_{mod}$				
	Flange A	Flange B		CNA Connector nail								
				4,0x35	4,0x40	4,0x50	4,0x60	4,0x35	4,0x40	4,0x50	4,0x60	
Nailing pattern 1	8	10	P	2,2	2,6	3,3	4,1	3,8	4,3	4,8	5,8	
			L	2,5	2,9	3,8	4,7	4,4	5,0	5,6	6,8	
			M	2,8	3,3	4,3	5,4	5,0	5,7	6,5	7,8	
			S	3,1	3,7	4,8	6,0	5,7	6,4	7,3	8,7	
			I	3,7	4,5	5,9	7,3	6,9	7,8	8,9	10,7	

Wane may occur under the angle brackets.

Table D10-4 Modified characteristic capacity timber beam to timber beam – 1 Angle Bracket

1 Angle Bracket ABR9015 per connection			Modified characteristic capacity per connection (kN)								
Nailing pattern	Number of fasteners		Load duration	$R_{1,k} \times k_{mod}$				$R_{2/3,k} \times k_{mod}$			
	Flange A	Flange B		CNA Connector nail				4,0x35	4,0x40	4,0x50	4,0x60
				4,0x35	4,0x40	4,0x50	4,0x60	4,0x35	4,0x40	4,0x50	4,0x60
Nailing pattern 1	8	10	P	$f \leq 8$ : $\frac{57}{f+32}$ $f > 8$ : $\frac{11,3}{f}$	$f \leq 10$ : $\frac{59}{f+32}$ $f > 10$ : $\frac{13,8}{f}$	$f \leq 13$ : $\frac{64}{f+32}$ $f > 13$ : $\frac{18,2}{f}$	$f \leq 16$ : $\frac{69}{f+32}$ $f > 16$ : $\frac{22,9}{f}$	1,9	2,1	2,4	2,9
			L	$f \leq 9$ : $\frac{59}{f+32}$ $f > 9$ : $\frac{13,2}{f}$	$f \leq 12$ : $\frac{62}{f+32}$ $f > 12$ : $\frac{16,1}{f}$	$f \leq 15$ : $\frac{67}{f+32}$ $f > 15$ : $\frac{21,3}{f}$	$f \leq 19$ : $\frac{73}{f+32}$ $f > 19$ : $\frac{26,7}{f}$	2,2	2,5	2,8	3,4
			M	$f \leq 10$ : $\frac{61}{f+32}$ $f > 10$ : $\frac{15,1}{f}$	$f \leq 13$ : $\frac{64}{f+32}$ $f > 13$ : $\frac{18,4}{f}$	$f \leq 17$ : $\frac{70}{f+32}$ $f > 17$ : $\frac{24,3}{f}$	$f \leq 21$ : $\frac{77}{f+32}$ $f > 21$ : $\frac{30,5}{f}$	2,5	2,8	3,2	3,9
			S	$f \leq 12$ : $\frac{62,6}{f+32}$ $f > 12$ : $\frac{17}{f}$	$f \leq 15$ : $\frac{66,4}{f+32}$ $f > 15$ : $\frac{20,6}{f}$	$f \leq 19$ : $\frac{73}{f+32}$ $f > 19$ : $\frac{27,3}{f}$	$f \leq 24$ : $\frac{81}{f+32}$ $f > 24$ : $\frac{34,3}{f}$	2,8	3,2	3,6	4,4
			I	$f \leq 15$ : $\frac{66,6}{f+32}$ $f > 15$ : $\frac{20,8}{f}$	$f \leq 17$ : $\frac{71,2}{f+32}$ $f > 17$ : $\frac{25,2}{f}$	$f \leq 23$ : $\frac{80}{f+32}$ $f > 23$ : $\frac{33,4}{f}$	$f \leq 29$ : $\frac{89}{f+32}$ $f > 29$ : $\frac{41,9}{f}$	3,5	3,9	4,4	5,3

Wane may occur under the angle bracket.

Table D10-5 Characteristic capacity timber beam to concrete – 2 Angle Brackets

2 Angle Brackets ABR9015 per connection			Characteristic capacity per connection (kN)
Nailing pattern	Number of fasteners		$R_{1,k}$
	Flange A	Flange B	
Nailing pattern 2	8 x CNA4,0x40	1 x PHNW-37 *)	13,2

\*) In pre-drilled hole  $\varnothing 5 \times 18$  mm



## Annex D11 – ABR9020

### Product Name:

Product Name	Material reference acc. to clause II-1	Alternative product names
ABR9020	Steel ref. 1	-
ABR9020S	Steel ref. 2	-
ABR9020S2	Steel ref. 3	-

### Connector Size Range:

Model no.	Dimensions [mm]				Holes flange A		Holes flange B	
	A	B	C	Thickness	Ø5	Ø11	Ø5	Ø13
ABR9020	88	88	65	2,0	10	1	10	1

### Drawing:

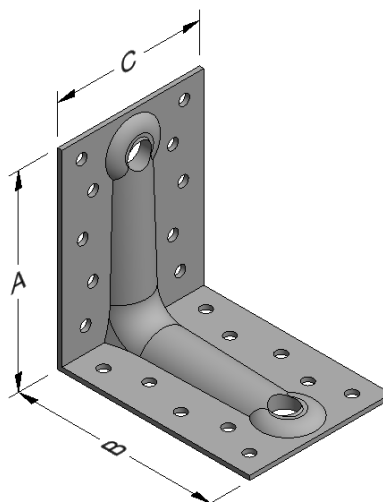

### Nailing pattern:

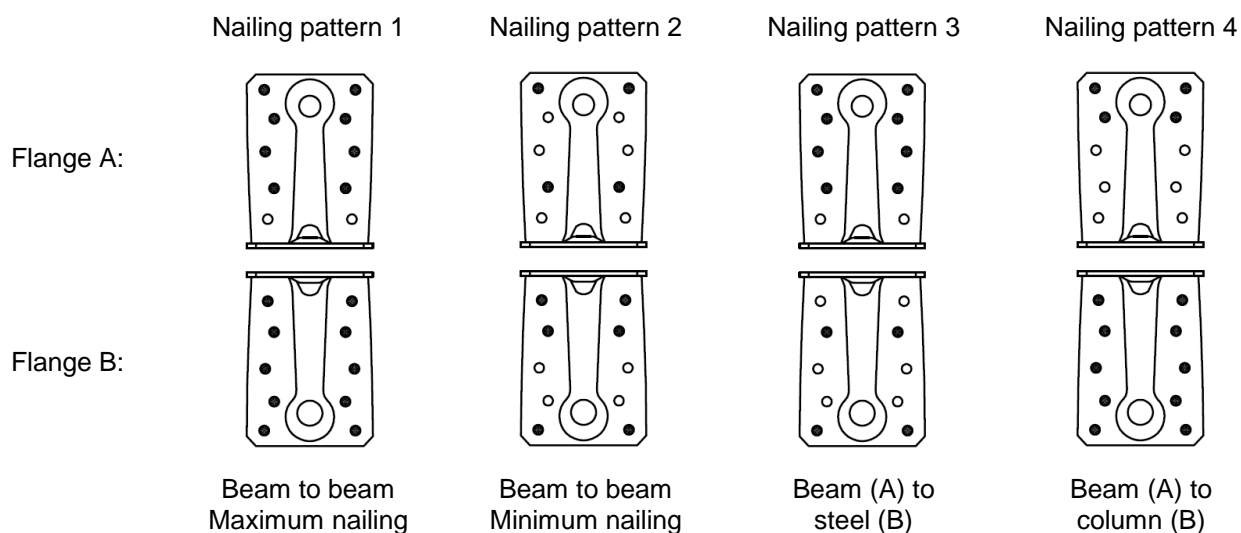

Table D11-1 Modified characteristic capacity timber beam to timber beam - 2 Angle Brackets

2 Angle Bracket ABR9015 per connection			Modified characteristic capacity per connection (kN)			
Nailing pattern	Number of fasteners		Load duration	$R_{1,k} \times k_{mod}$	$R_{2/3,k} \times k_{mod}$	$R_{4/5,k} \times k_{mod}$
	Flange A	Flange B		CSA Connector screw 5,0x40		
Nailing pattern 1	8	10	P	8,0	6,3	$\frac{4.1 \cdot b + 210}{e}$ max 19,4
			L	9,3	7,3	$\frac{4.5 \cdot b + 215}{e}$ max 22,6
			M	10,6	8,4	$\frac{4.9 \cdot b + 219}{e}$ max 25,7
			S	11,8	9,4	$\frac{5.3 \cdot b + 224}{e}$ max 28,8
			I	14,4	11,5	$\frac{6.2 \cdot b + 227}{e}$ max 35,1

Wane may occur under the angle brackets.

Table D11-2 Modified characteristic capacity timber beam to timber beam – 1 Angle Bracket

1 Angle Bracket ABR9020 per connection			Modified characteristic capacity per connection (kN)							
Nailing pattern	Number of fasteners		Load duration	$R_{1,k} \times k_{mod}$	$R_{2/3,k} \times k_{mod}$	$R_{4,k} \times k_{mod}$	$R_{5,k} \times k_{mod}$			
	Flange A	Flange B		CSA Connector Screw 5,0x40						
Nailing pattern 1	8	10	P	$f \leq 100$ : $\frac{62,8}{f+29}$	3,7	$e \leq 8$ : 10,8	$e \leq 48$ : $\frac{134}{65-e}$			
				$f > 100$ : $\frac{49,1}{f+1}$		$8 < e \leq 63$ : $\frac{90,9}{e}$	$48 < e \leq 0,66 \cdot b + 28$ : 8			
			L	$f \leq 61$ : $\frac{71,2}{f+29}$	4,3	$e \leq 7$ : 12,6	$e \leq 48$ : $\frac{156}{65-e}$			
				$f > 61$ : $\frac{49,1}{f+1}$		$7 < e \leq 63$ : $\frac{90,9}{e}$	$48 < e \leq 0,63 \cdot b + 29$ : 9,2			
			M	$f \leq 44$ : $\frac{79,6}{f+29}$	4,9	$e \leq 6$ : 14,4	$e \leq 48$ : $\frac{178}{65-e}$			
				$f > 44$ : $\frac{49,1}{f+1}$		$6 < e \leq 63$ : $\frac{90,9}{e}$	$45 < e \leq 0,61 \cdot b + 29$ : 10,5			
			S	$f \leq 34$ : $\frac{88}{f+29}$	5,6	$e \leq 6$ : 16,2	$e \leq 48$ : $\frac{200}{65-e}$			
				$f > 34$ : $\frac{49,1}{f+1}$		$6 < e \leq 63$ : $\frac{90,9}{e}$	$48 < e \leq 0,59 \cdot b + 29$ : 11,7			
			I	$f \leq 24$ : $\frac{104,8}{f+29}$	6,8	$e \leq 5$ : 19,8	$e \leq 48$ : $\frac{245}{65-e}$			
				$f > 24$ : $\frac{49,1}{f+1}$		$5 < e \leq 63$ : $\frac{90,9}{e}$	$48 < e \leq 0,57 \cdot b + 30$ : 14,1			
									$e > 63$ : $\frac{49,1}{e-29}$	$e > 0,57 \cdot b + 30$ : $\frac{8 \cdot b - 493}{e-65}$

f is in mm.

Table D11-3 Modified characteristic capacity timber beam to timber beam – 2 Angle Brackets

2 Angle Brackets ABR9020 per connection			Modified characteristic capacity per connection (kN)									
Nailing pattern	Number of fasteners		Load duration	$R_{1,k} \times k_{mod}$			$R_{2/3,k} \times k_{mod}$			$R_{4/5,k} \times k_{mod}$		
	Flange A	Flange B		CNA Connector nail								
				4,0x35	4,0x40	4,0x60	4,0x35	4,0x40	4,0x60	4,0x35	4,0x40	4,0x60
Nailing pattern 1	8	10	P	5,8	6,5	8,9	5,7	6,2	7,8	$\frac{3.6 \cdot b + 259}{e}$ max 5,9	$\frac{3.9 \cdot b + 261}{e}$ max 6,8	$\frac{4.8 \cdot b + 269}{e}$ max 10,7
			L	6,8	7,6	10,4	6,6	7,2	9,1	$\frac{3.8 \cdot b + 260}{e}$ max 6,7	$\frac{4.1 \cdot b + 263}{e}$ max 7,8	$\frac{5.2 \cdot b + 273}{e}$ max 12,4
			M	7,8	8,6	11,9	7,5	8,3	10,4	$\frac{4.0 \cdot b + 262}{e}$ max 7,5	$\frac{4.3 \cdot b + 265}{e}$ max 8,8	$\frac{5.5 \cdot b + 276}{e}$ max 14,0
			S	8,7	9,7	13,4	8,5	9,3	11,7	$\frac{4.2 \cdot b + 264}{e}$ max 8,3	$\frac{4.5 \cdot b + 267}{e}$ max 9,8	$\frac{5.9 \cdot b + 279}{e}$ max 15,6
			I	10,7	11,9	16,4	10,4	11,4	14,4	$\frac{4.6 \cdot b + 267}{e}$ max 9,9	$\frac{5.0 \cdot b + 271}{e}$ max 11,7	$\frac{6.7 \cdot b + 286}{e}$ max 18,9
Nailing pattern 2	4	6	P	2,9	3,5	5,9	3,5	3,8	4,9	$\frac{3.6 \cdot b + 259}{e}$ max 3,7	$\frac{3.9 \cdot b + 261}{e}$ max 4,2	$\frac{4.8 \cdot b + 269}{e}$ max 6,3
			L	3,4	4,1	6,9	4,1	4,5	5,7	$\frac{3.8 \cdot b + 260}{e}$ max 4,1	$\frac{4.1 \cdot b + 263}{e}$ max 4,7	$\frac{5.2 \cdot b + 273}{e}$ max 7,2
			M	3,9	4,7	7,8	4,7	5,1	6,5	$\frac{4.0 \cdot b + 262}{e}$ max 4,5	$\frac{4.3 \cdot b + 265}{e}$ max 5,3	$\frac{5.5 \cdot b + 276}{e}$ max 8,1
			S	4,4	5,3	8,8	5,3	5,8	7,3	$\frac{4.2 \cdot b + 264}{e}$ max 5,0	$\frac{4.5 \cdot b + 267}{e}$ max 5,8	$\frac{5.9 \cdot b + 279}{e}$ max 9,0
			I	5,4	6,5	10,8	6,5	7,1	9,0	$\frac{4.6 \cdot b + 267}{e}$ max 5,9	$\frac{5.0 \cdot b + 271}{e}$ max 6,9	$\frac{6.7 \cdot b + 286}{e}$ max 10,8

b and e are in mm.

Table D11-4 Modified characteristic capacity timber beam to timber beam – 1 Angle Bracket, maximum nailing

Table D11-4.1 R<sub>1</sub> & R<sub>2/3</sub>

1 Angle Bracket ABR9020 per connection			Modified characteristic capacity per connection (kN)						
Nailing pattern	Number of fasteners		Load duration	R <sub>1,k</sub> x k <sub>mod</sub>			R <sub>2/3,k</sub> x k <sub>mod</sub>		
	Flange A	Flange B		CNA Connector nail					
				4,0x35	4,0x40	4,0x60	4,0x35	4,0x40	4,0x60
Nailing pattern 1	8	10	P	f ≤ 27: <u>63</u> f+40	f ≤ 32: <u>69</u> f+40	f ≤ 46: <u>90</u> f+40	2,8	3,1	3,9
				f > 27: <u>26.5</u> f+1	f > 32: <u>31.8</u> f+1	f > 46: <u>49.4</u> f+1			
			L	f ≤ 32: <u>68</u> f+40	f ≤ 38: <u>74</u> f+40	f ≤ 38: <u>99</u> f+40	3,3	3,6	4,6
				f > 32: <u>30.9</u> f+1	f > 38: <u>37</u> f+1	f > 38: <u>49.4</u> f+1			
			M	f ≤ 36: <u>72</u> f+40	f ≤ 44: <u>79</u> f+40	f ≤ 32: <u>107</u> f+40	3,8	4,1	5,2
f > 36: <u>35.3</u> f+1	f > 44: <u>42.3</u> f+1	f > 32: <u>49.4</u> f+1							
S	f ≤ 41: <u>77</u> f+40	f ≤ 49: <u>84</u> f+40	f ≤ 28: <u>116</u> f+40	4,2	4,7	5,9			
	f > 41: <u>39.7</u> f+1	f > 49: <u>47.6</u> f+1	f > 28: <u>49.4</u> f+1						
I	f ≤ 50: <u>85</u> f+40	f ≤ 41: <u>95</u> f+40	f ≤ 22: <u>134</u> f+40	5,2	5,7	7,2			
	f > 50: <u>48.5</u> f+1	f > 41: <u>49.4</u> f+1	f > 22: <u>49.4</u> f+1						

f, e and b are in mm.

Table D11-4.2 R<sub>4</sub> & R<sub>5</sub>

1 Angle Bracket ABR9020 per connection			Modified characteristic capacity per connection (kN)						
Nailing pattern	Number of fasteners		Load duration	R <sub>4,k</sub> x k <sub>mod</sub>			R <sub>5,k</sub> x k <sub>mod</sub>		
	Flange A	Flange B		CNA Connector nail					
				4,0x35	4,0x40	4,0x60	4,0x35	4,0x40	4,0x60
Nailing pattern 1	8	10	P	e ≤ 10: 6,0	e ≤ 10: 6,6	e ≤ 10: 8,5	e ≤ 51:	e ≤ 50:	e ≤ 48:
				10 < e ≤ 145:	10 < e ≤ 120:	10 < e ≤ 70:	<u>39</u>	<u>46.7</u>	<u>77.9</u>
				<u>60</u>	<u>65</u>	<u>84</u>	65-e	65-e	65-e
				e > 145:	e > 120:	e > 70:	51 < e ≤ 1,18·b+14:	50 < e ≤ 1,09·b+16:	48 < e ≤ 0,89·b+20:
				<u>49</u>	<u>49</u>	<u>49</u>	2,8	3,1	4,6
				e-29	e-29	e-29	e > 1,18·b+14:	e > 1,09·b+16:	e > 0,89·b+20:
							<u>3.3-b-140</u>	<u>3.4-b-153</u>	<u>4.1-b-204</u>
							e-65	e-65	e-65
			L	e ≤ 9: 7,0	e ≤ 9: 7,7	e ≤ 9: 9,9	e ≤ 50:	e ≤ 49:	e ≤ 47:
				9 < e ≤ 130:	9 < e ≤ 100:	9 < e ≤ 62:	<u>45.5</u>	<u>54.5</u>	<u>90.9</u>
				<u>64</u>	<u>70</u>	<u>91</u>	65-e	65-e	65-e
				e > 130:	e > 100:	e > 62:	50 < e ≤ 1,11·b+16:	49 < e ≤ 1,03·b+18:	47 < e ≤ 0,84·b+21:
				<u>49</u>	<u>49</u>	<u>49</u>	3,1	3,5	5,2
				e-29	e-29	e-29	e > 1,11·b+16:	e > 1,03·b+18:	e > 0,84·b+21:
							<u>3.4-b-151</u>	<u>3.6-b-166</u>	<u>4.4-b-226</u>
							e-65	e-65	e-65
			M	e ≤ 8: 8,0	e ≤ 8: 8,8	e ≤ 9: 11,3	e ≤ 50:	e ≤ 49:	e ≤ 47:
				8 < e ≤ 105:	8 < e ≤ 85:	9 < e ≤ 57:	<u>52</u>	<u>62</u>	<u>104</u>
				<u>68</u>	<u>74</u>	<u>99</u>	65-e	65-e	65-e
				e > 105:	e > 85:	e > 57:	50 < e ≤ 1,05·b+17:	49 < e ≤ 0,97·b+19:	47 < e ≤ 0,80·b+22:
				<u>49</u>	<u>49</u>	<u>49</u>	3,4	3,9	5,8
				e-29	e-29	e-29	e > 1,05·b+17:	e > 0,97·b+19:	e > 0,80·b+22:
				<u>3.5-b-162</u>	<u>3.8-b-179</u>	<u>4.6-b-247</u>			
				e-65	e-65	e-65			
S	e ≤ 8: 9,1	e ≤ 8: 9,9	e ≤ 8: 12,8	e ≤ 49:	e ≤ 48:	e ≤ 47:			
	8 < e ≤ 92:	8 < e ≤ 77:	8 < e ≤ 56:	<u>58</u>	<u>70</u>	<u>117</u>			
	<u>72</u>	<u>79</u>	<u>101</u>	65-e	65-e	65-e			
	e > 92:	e > 77:	e > 56:	49 < e ≤ 1,00·b+18:	48 < e ≤ 0,93·b+20:	47 < e ≤ 0,77·b+23:			
	<u>49</u>	<u>49</u>	<u>49</u>	3,7	4,2	6,4			
	e-29	e-29	e-29	e > 1,00·b+18:	e > 0,93·b+20:	e > 0,77·b+23:			
				<u>3.7-b-173</u>	<u>3.9-b-192</u>	<u>4.9-b-268</u>			
				e-65	e-65	e-65			
I	e ≤ 7: 11,1	e ≤ 7: 12,1	e ≤ 6: 15,6	e ≤ 48:	e ≤ 48:	e ≤ 46:			
	7 < e ≤ 75:	7 < e ≤ 65:	6 < e ≤ 56:	<u>71</u>	<u>86</u>	<u>143</u>			
	<u>80</u>	<u>88</u>	<u>101</u>	65-e	65-e	65-e			
	e > 75:	e > 65:	e > 56:	48 < e ≤ 0,92·b+20:	48 < e ≤ 0,86·b+21:	46 < e ≤ 0,72·b+24:			
	<u>49</u>	<u>49</u>	<u>49</u>	4,3	4,9	7,6			
	e-29	e-29	e-29	e > 0,92·b+20:	e > 0,86·b+21:	e > 0,72·b+24:			
				<u>3.9-b-194</u>	<u>4.2-b-217</u>	<u>5.4-b-311</u>			
				e-65	e-65	e-65			

f, e and b are in mm.

Table D11-5 Modified characteristic capacity timber beam to timber beam – 1 Angle Bracket, minimum nailing

Table D11-5.1 R<sub>1</sub> & R<sub>2/3</sub>

1 Angle Bracket ABR9020 per connection			Modified characteristic capacity per connection (kN)						
Nailing pattern	Number of fasteners		Load duration	R <sub>1,k</sub> x k <sub>mod</sub>			R <sub>2/3,k</sub> x k <sub>mod</sub>		
	Flange A	Flange B		CNA Connector nail					
				4,0x35	4,0x40	4,0x60	4,0x35	4,0x40	4,0x60
Nailing pattern 2	4	6	P	f ≤ 27: <u>63</u> f+40	f ≤ 33: <u>69</u> f+40	f ≤ 46: <u>90</u> f+40	1,8	1,9	2,4
				f > 27: <u>26,5</u> f+1	f > 33: <u>31,8</u> f+1	f > 46: <u>49,4</u> f+1			
			L	f ≤ 32: <u>68</u> f+40	f ≤ 38: <u>74</u> f+40	f ≤ 38: <u>99</u> f+40	2,1	2,2	2,9
				f > 32: <u>30,9</u> f+1	f > 38: <u>37,0</u> f+1	f > 38: <u>49,4</u> f+1			
			M	f ≤ 36: <u>72</u> f+40	f ≤ 44: <u>79</u> f+40	f ≤ 32: <u>107</u> f+40	2,4	2,6	3,3
f > 36: <u>35,3</u> f+1	f > 44: <u>42,3</u> f+1	f > 32: <u>49,4</u> f+1							
S	f ≤ 41: <u>77</u> f+40	f ≤ 49: <u>84</u> f+40	f ≤ 28: <u>116</u> f+40	2,7	2,9	3,7			
	f > 41: <u>39,7</u> f+1	f > 49: <u>47,6</u> f+1	f > 28: <u>49,4</u> f+1						
I	f ≤ 50: <u>85</u> f+40	f ≤ 41: <u>95</u> f+40	f ≤ 22: <u>134</u> f+40	3,2	3,5	4,5			
	f > 50: <u>48,5</u> f+1	f > 41: <u>49,4</u> f+1	f > 22: <u>49,4</u> f+1						

f, e and b are in mm.

Table D11-5.2 R<sub>4</sub> & R<sub>5</sub>

1 Angle Bracket ABR9020 per connection			Modified characteristic capacity per connection (kN)							
Nailing pattern	Number of fasteners		Load duration	R <sub>4,k</sub> x k <sub>mod</sub>			R <sub>5,k</sub> x k <sub>mod</sub>			
	Flange A	Flange B		CNA Connector nail						
				4,0x35	4,0x40	4,0x60	4,0x35	4,0x40	4,0x60	
Nailing pattern 2	4	6	P	e ≤ 30: 2,0	e ≤ 29: 2,2	e ≤ 29: 2,8	e ≤ 55:	e ≤ 55:	e ≤ 53:	
				30 < e ≤ 150:	29 < e ≤ 120:	29 < e ≤ 70:	<u>26,5</u>	<u>31,8</u>	<u>52,9</u>	
				<u>60</u>	<u>65</u>	<u>84</u>	65-e	65-e	65-e	
				e	e	e	55 < e ≤ 1,18·b+2:	55 < e ≤ 1,09·b+3:	53 < e ≤ 0,89·b+5:	
				e > 150:	e > 120:	e > 70:	2,8	3,1	4,6	
				<u>49</u>	<u>49</u>	<u>49</u>	e > 1,18·b+2:	e > 1,09·b+3:	e > 0,89·b+5:	
				e-29	e-29	e-29	<u>3,3·b-176</u>	<u>3,4·b-196</u>	<u>4,1·b-275</u>	
							e-65	e-65	e-65	
				L	e ≤ 27: 2,3	e ≤ 27: 2,6	e ≤ 28: 3,3	e ≤ 55:	e ≤ 54:	e ≤ 53:
					27 < e ≤ 120:	27 < e ≤ 97:	28 < e ≤ 62:	<u>30,9</u>	<u>37,0</u>	<u>61,7</u>
					<u>64</u>	<u>70</u>	<u>91</u>	65-e	65-e	65-e
					e	e	e	55 < e ≤ 1,11·b+3:	54 < e ≤ 1,03·b+3:	53 < e ≤ 0,84·b+5:
			e > 120:		e > 97:	e > 62:	3,1	3,5	5,2	
			<u>49</u>		<u>49</u>	<u>49</u>	e > 1,11·b+3:	e > 1,03·b+3:	e > 0,84·b+5:	
			e-29		e-29	e-29	<u>3,4·b-192</u>	<u>3,6·b-215</u>	<u>4,4·b-308</u>	
							e-65	e-65	e-65	
			M		e ≤ 25: 2,7	e ≤ 25: 2,9	e ≤ 26: 3,8	e ≤ 55:	e ≤ 54:	e ≤ 53:
					25 < e ≤ 105:	25 < e ≤ 85:	26 < e ≤ 57:	<u>35</u>	<u>42,0</u>	<u>71,0</u>
					<u>68</u>	<u>74</u>	<u>99</u>	65-e	65-e	65-e
					e	e	e	55 < e ≤ 1,05·b+3:	54 < e ≤ 0,97·b+4:	53 < e ≤ 0,80·b+6:
				e > 105:	e > 85:	e > 57:	3,4	3,9	5,8	
				<u>49</u>	<u>49</u>	<u>49</u>	e > 1,05·b+3:	e > 0,97·b+4:	e > 0,80·b+6:	
				e-29	e-29	e-29	<u>3,5·b-209</u>	<u>3,8·b-235</u>	<u>4,6·b-341</u>	
							e-65	e-65	e-65	
S	e ≤ 24: 3,0	e ≤ 24: 3,3		e ≤ 24: 4,3	e ≤ 54:	e ≤ 54:	e ≤ 53:			
	24 < e ≤ 92:	24 < e ≤ 77:		24 < e ≤ 56:	<u>40</u>	<u>48,0</u>	<u>79,0</u>			
	<u>72</u>	<u>79</u>		<u>101</u>	65-e	65-e	65-e			
	e	e		e	54 < e ≤ 1,00·b+4:	54 < e ≤ 0,93·b+4:	53 < e ≤ 0,77·b+6:			
	e > 92:	e > 77:	e > 56:	3,7	4,2	6,4				
	<u>49</u>	<u>49</u>	<u>49</u>	e > 1,00·b+4:	e > 0,93·b+4:	e > 0,77·b+6:				
	e-29	e-29	e-29	<u>3,7·b-225</u>	<u>3,9·b-255</u>	<u>4,9·b-374</u>				
				e-65	e-65	e-65				
	I	e ≤ 22: 3,7	e ≤ 22: 4,0	e ≤ 19: 5,2	e ≤ 54:	e ≤ 53:	e ≤ 52:			
		22 < e ≤ 75:	22 < e ≤ 65:	19 < e ≤ 56:	<u>49</u>	<u>58,0</u>	<u>97,0</u>			
		<u>80</u>	<u>88</u>	<u>101</u>	65-e	65-e	65-e			
		e	e	e	54 < e ≤ 0,92·b+5:	53 < e ≤ 0,86·b+5:	52 < e ≤ 0,72·b+7:			
e > 75:		e > 65:	e > 56:	4,3	4,9	7,6				
<u>49</u>		<u>49</u>	<u>49</u>	e > 0,92·b+5:	e > 0,86·b+5:	e > 0,72·b+7:				
e-29		e-29	e-29	<u>3,9·b-259</u>	<u>4,2·b-295</u>	<u>5,4·b-441</u>				
				e-65	e-65	e-65				



Table D11-6 Characteristic capacity timber beam to 6 mm steel beam – 2 Angle Brackets

2 Angle Brackets ABR9020 per connection			Characteristic capacity per connection (kN)
Nailing pattern	Number of fasteners		$R_{1,k}$
	Flange A	Flange B	
Nailing pattern 3	8 x CNA4,0x60	4 x PDPA-75	12,1

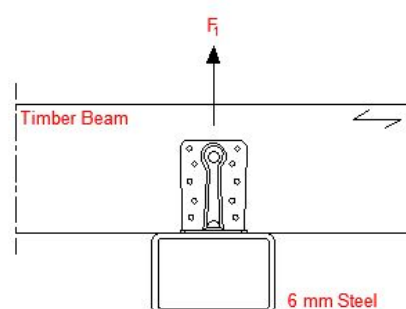

Table D11-7 1 angle brackets ABR9020, beam to column

1 ABR9020	Characteristic capacity per connection [kN]			
	$R_{1,k}$		$R_{2,k}$	
	4,0x40	4,0x60	4,0x40	4,0x60
Nailing 4+10 see fig. 11-5	7,7	10,4	1,5	2,5

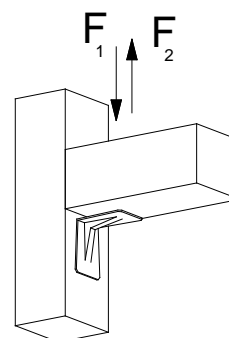

Table D11-8 ABR9020 Slip modulus  $K_{ser}$

2 ABR9020		$K_{ser}$ [kN/mm]			
For force	Nailing	CNA4.0x35	CNA4.0x40	CNA4.0x50	CNA4.0x60
F1	Max	3,9	4,3	5,1	5,9
	Min	1,9	2,3	3,1	3,9
F2	Max	1,2	1,4	1,5	1,7
	Min	0,6	0,7	0,8	0,9

Table D11-9 Modified characteristic capacity timber beam to timber column – 1 Angle Bracket

1 Angle Bracket ABR9020 per connection				Modified characteristic capacity per connection (kN)			
Nailing pattern	Number of Fasteners		Load duration	$R_{1,k} \times k_{mod}$		$R_{2,k} \times k_{mod}$	
	Flange A (beam)	Flange B (column)		CNA4,0x40	CNA4,0x60	CNA4,0x40	CNA4,0x60
Nailing pattern 4	4	10	P	4,6	6,2	0,9	1,5
			L	5,4	7,3	1,1	1,8
			M	6,2	8,3	1,2	2,0
			S	6,9	9,4	1,4	2,3
			I	8,5	11,4	1,7	2,8

General note to capacity tables:

b, e and f are in mm.

Wane may not occur under the angle bracket.

## Annex D12 – ABR100

### Product Name:

Product Name	Material reference acc. to clause II-1	Alternative product names
ABR100	Steel ref. 1	-
ABR100S	Steel ref. 2	-
ABR100S2	Steel ref. 3	-

### Connector Size Range:

Model no.	Dimensions [mm]				Holes flange A		Holes flange B	
	A	B	C	Thickness	Ø5	Ø12	Ø5	Ø11
ABR100	100	100	90	2,0	10	2	14	1

### Drawing:

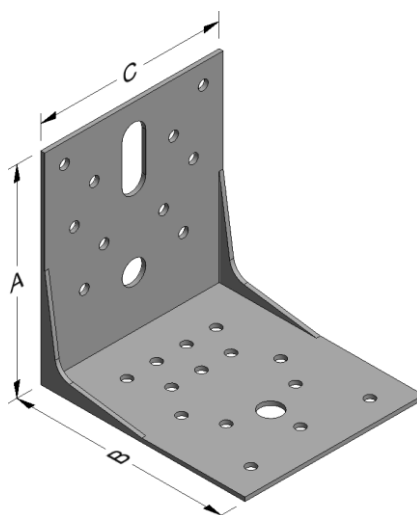

### Nailing pattern:

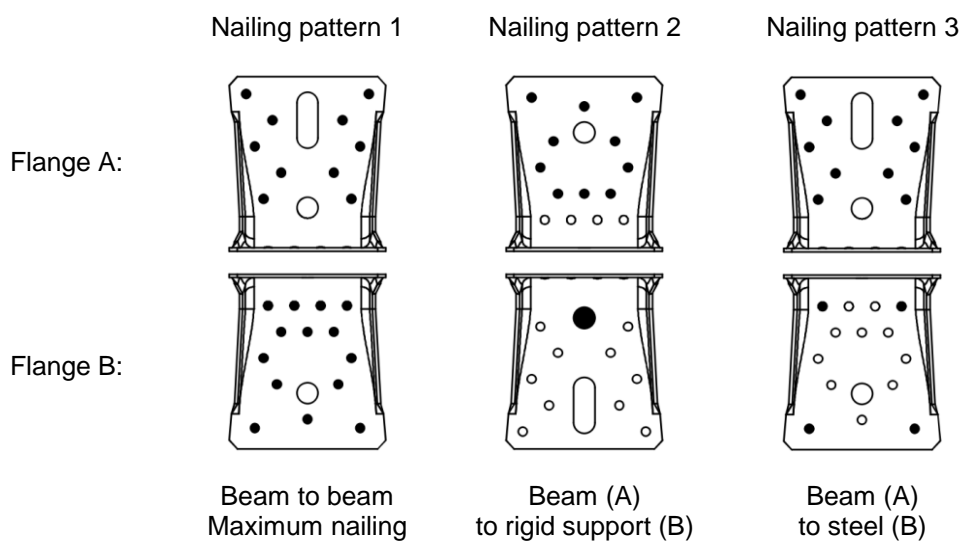

*Table D12-1 Modified characteristic capacity timber beam to timber beam – 2 Angle Brackets*

2 Angle Brackets ABR100 per connection			Modified characteristic capacity per connection (kN)				
Nailing pattern	Number of fasteners		Load duration	$R_{1,k} \times k_{mod}$		$R_{2/3,k} \times k_{mod}$	
	Flange A	Flange B		CSA Connector screw			
				5,0x35	5,0x40	5,0x35	5,0x40
Nailing pattern 1	10	14	P	15,0	17,6	10,5	12,0
			L	17,5	20,5	12,3	14,0
			M	20,0	22,5	14,0	16,0
			S	22,0	24,0	15,8	18,0
			I	24,6	27,0	19,3	22,0

Characteristic loads for CSA 5.0x50 have not been evaluated. You can consider capacities for CSA 5.0x40 in a safe way.

Wane may not occur under the angle brackets.

Table D12-2 Modified characteristic capacity timber beam to timber beam – 1 Angle Bracket

1 Angle Bracket ABR100 per connection			Modified characteristic capacity per connection (kN)				
Nailing pattern	Number of fasteners		Load duration	$R_{1,k} \times k_{mod}$		$R_{2/3,k} \times k_{mod}$	
	Flange A	Flange B		CSA Connector screw			
			5,0x35	5,0x40	5,0x35	5,0x40	
Nailing pattern 1	10	14	P	$f \leq 30 :$ $\frac{239,8}{f + 55,5}$	$f \leq 21 :$ $\frac{277,3}{f + 55,5}$	5,3	6,0
				$21 < f \leq 26 :$ $\frac{140,8}{f + 18}$	$21 < f \leq 26 :$ $\frac{140,8}{f + 18}$		
				$f > 30 :$ $\frac{84,5}{f}$	$f > 26 :$ $\frac{84,5}{f}$		
			L	$f \leq 21 :$ $\frac{276,4}{f + 55,5}$	$f \leq 12 :$ $\frac{320,1}{f + 55,5}$	6,1	7
				$21 < f \leq 26 :$ $\frac{140,8}{f + 18}$	$12 < f \leq 26 :$ $\frac{140,8}{f + 18}$		
	$f > 26 :$ $\frac{84,5}{f}$	$f > 26 :$ $\frac{84,5}{f}$					
M	$f \leq 13 :$ $\frac{313}{f + 55,5}$	$f \leq 6 :$ $\frac{363}{f + 55,5}$	7,0	8			
	$13 < f \leq 26 :$ $\frac{140,8}{f + 18}$	$6 < f \leq 26 :$ $\frac{140,8}{f + 18}$					
	$f > 26 :$ $\frac{84,5}{f}$	$f > 26 :$ $\frac{84,5}{f}$					
S	$f \leq 8 :$ $\frac{349,6}{f + 55,5}$	$f \leq 2 :$ $\frac{405,9}{f + 55,5}$	7,9	9			
	$8 < f \leq 26 :$ $\frac{140,8}{f + 18}$	$2 < f \leq 26 :$ $\frac{140,8}{f + 18}$					
	$f > 26 :$ $\frac{84,5}{f}$	$f > 26 :$ $\frac{84,5}{f}$					
I	$f \leq 26 :$ $\frac{140,8}{f + 18}$	$f \leq 26 :$ $\frac{140,8}{f + 18}$	9,7	11			
	$f > 26 :$ $\frac{84,5}{f}$	$f > 26 :$ $\frac{84,5}{f}$					

Wane may not occur under the angle bracket.

Table D12-3 Characteristic capacity timber beam to timber beam – 2 Angle Brackets

2 Angle Brackets ABR100 per connection			Characteristic capacity per connection (kN)												
Nailing pattern	Number of fasteners		R <sub>1,k</sub>				R <sub>2/3,k</sub>				R <sub>4/5,k</sub>				
	Flange A	Flange B	4,0x35	4,0x40	4,0x50	4,0x60	CNA Connector nail				e [mm]=	4,0x35	4,0x40	4,0x50	4,0x60
Nailing pattern 1	10,00	14,00	9,70	11,70	15,70	19,70	9,60	12,80	14,20	16,70	0	14,19	15,45	16,10	16,76
											20	11,55	13,71	18,04	19,18
											50	8,20	8,93	10,38	10,99
											100	2,40	4,20	5,14	5,14
											150	0,83	2,15	2,73	2,94

Wane may not occur under the angle brackets.

Table D12-4 Characteristic capacity timber beam to timber beam – 1 Angle Bracket

2 Angle Brackets ABR100 per connection			Characteristic capacity per connection (kN)																
Nailing pattern	Number of fasteners		R <sub>1,k</sub>				R <sub>2/3,k</sub> <sup>1)</sup>				R <sub>4,k</sub>				R <sub>5,k</sub>				
	Flange A	Flange B	4,0x35	4,0x40	4,0x50	4,0x60	4,0x35	4,0x40	4,0x50	4,0x60	CNA Connector nail				4,0x35	4,0x40	4,0x50	4,0x60	
Nailing pattern 1	10	14	a = 140	a = 164	a = 212	a = 256	4,8	6,4	7,1	8,3	e [mm]=	4,0x35	4,0x40	4,0x50	4,0x60	4,0x35	4,0x40	4,0x50	4,0x60
			0	12,55	12,55	12,55					12,55	1,64	1,97	2,62	3,28				
			20	8,70	10,29	12,55					12,55	2,85	3,42	4,56	5,70				
			50	3,70	4,43	5,22					5,51	4,50	4,50	4,50	4,50				
			100	-	0,77/k <sub>mod</sub>						1,63	1,96	2,25	2,25					
150	-	0,29/k <sub>mod</sub>			0,54	0,65	0,87	1,09											

<sup>1)</sup> the timber is prevented from rotation

Wane may not occur under the angle bracket.

Table D12-5 Modified characteristic capacity timber beam to rigid support – 2 Angle Brackets

2 Angle Brackets ABR100 per connection				Modified characteristic capacity per connection (kN)						
Nailing pattern	Number of fasteners		Load duration	R <sub>1,k</sub> x k <sub>mod</sub>			R <sub>2/3,k</sub> x k <sub>mod</sub>			R <sub>4/5,k</sub> x k <sub>mod</sub>
	Vertical flange (A)	Horizontal flange (B)		CNA 4,0x40	CNA 4,0x50	CNA 4,0x60	CNA 4,0x40	CNA 4,0x50	CNA 4,0x60	CNA 4,0x40 to CNA 4,0x60
Nailing pattern 2	10	1 bolt	P	12,4	16,0	18,7	5,2	6,5	7,4	6,24 <sup>1)</sup>
			L	14,5	18,6	21,6	6,1	7,6	8,6	7,28 <sup>1)</sup>
			M	16,5	21,3	21,6	6,9	8,7	9,8	8,32 <sup>1)</sup>
			S	18,6	21,6	21,6	7,8	9,8	11,1	9,36 <sup>1)</sup>
			I	21,6	21,6	21,6	9,5	12,0	13,5	11,44 <sup>1)</sup>

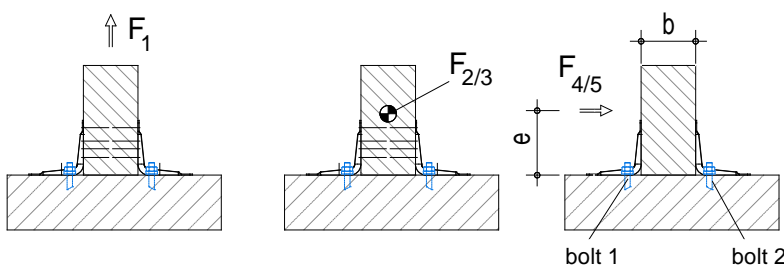

<sup>1)</sup> it is to check:  
 the bolt 1:  $R_{bolt,ax,d} \geq F_{4/5,d} \times e / b$   
 the bolt 2:  $R_{bolt,lat,d} \geq F_{4/5,d}$   
 and:  $R_{4/5,d} \leq R_{1,d} \times b / (2xe)$   
 for R<sub>1</sub>:  $R_{bolt,ax,d} \geq F_{1,d} / 2$   
 for R<sub>2/3</sub>:  $R_{bolt,lat,d} \geq F_{2/3,d} / 2$

Table D12-6 Characteristic capacity timber beam to rigid support – 1 Angle Bracket

1 Angle Bracket ABR100 per connection			Characteristic capacity per connection (kN)							
Nailing pattern	Number of fasteners		$R_{1,k}$	$R_{2,k}$		$R_{4,k}$ <sup>3)</sup>		$R_{5,k}$ <sup>3)</sup>		
	Flange A	Flange B				CNA Connector nail size 4,0x40 to 4,0x60				
Nailing pattern 2	10	1 Bolt	$R_{1,k} = \min \left\{ \begin{array}{l} \frac{22,45}{f^{0,7} \times k_{mod}} \\ 4,49 \\ k_{mod} \end{array} \right.$	2)		e [mm]	steel	timber	steel	timber
						0	-	9,0	-	2,26
						20	-		-	4,53
						50	4,55		4,50	8,40
						100	0,77		2,25	1,77
150	0,29	1,50	0,56							

2) the timber must free from turn away, also the half of capacity of 2 ABR100 it to use the values for timber may be to use with  $k_{mod}$ , the values for steel alltimes with  $k_{mod} = 1$  the minimum of both are available

3) it is to check for the bolt:  
 $R_{bolt,ax,d} \geq F_4 \text{ or } 5, d \times e / 40$   
 $R_{bolt,lat,d} \geq F_4 \text{ or } 5, d$

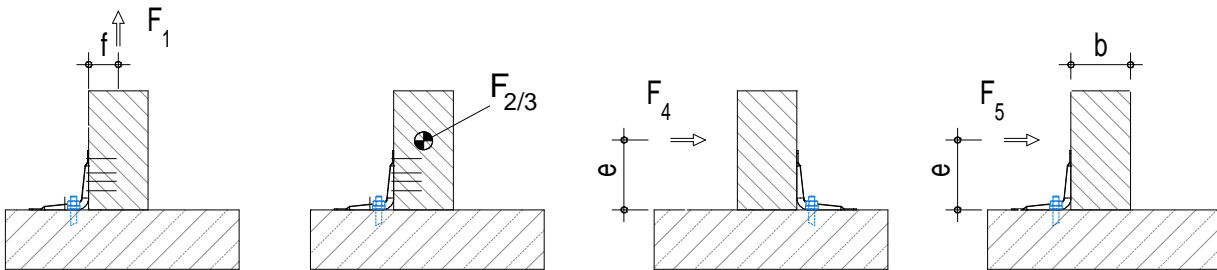

Table D12-7 Characteristic capacity timber beam to 6 mm steel beam connection – 2 Angle Brackets

2 Angle Brackets ABR100 per connection			Characteristic capacity per connection (kN)
			$R_{1,k}$
Nailing pattern	Number of fasteners		CNA Connector nail 4,0x60
	Flange A	Flange B	
Nailing pattern 3	10	4 PDPA-75	21,5

Table D12-8 ABR100 Slip modulus  $k_{ser}$

2 ABR100 per Connection	For $R_1$ $K_{ser}$ [kN/mm]	For $R_{2/3}$ $k_{ser}$ [kN/mm]
CNA4,0x35	1,45	1,37
CNA4,0x40	1,75	1,82
CNA4,0x50	2,35	2,02
CNA4,0x60	2,95	2,38
CSA5,0x40	5,06	5,82

## Annex D13 – AA60280

### Product Name:

Product Name	Material reference acc. to clause II-1	Alternative product names
AA60280	Steel ref. 1	-
AA60280S	Steel ref. 2	-
AA60280S2	Steel ref. 3	-

### Connector Size Range:

Model no.	Dimensions [mm]				Holes flange A	Holes flange B
	A	B	C	Thickness	Ø5	Ø5
AA60280	83	62	40	2,0	5	5

### Drawing:

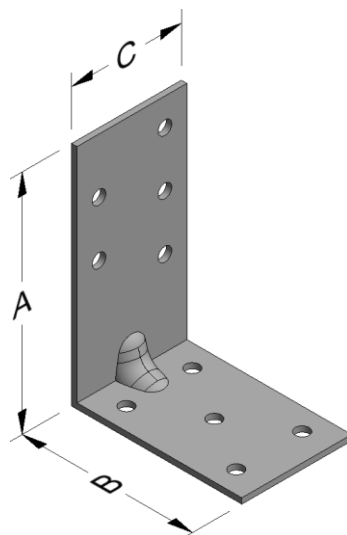

### Nailing pattern:

Nailing pattern 1

Flange A:

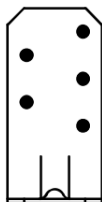

Flange B:

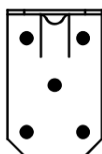

Beam to beam  
Maximum nailing

Table D13-1 Modified characteristic capacity timber beam to timber beam – 2 Angle Brackets

2 Angle Brackets AA60280 per connection			Modified characteristic capacity per connection (kN)						
Nailing pattern	Number of fasteners		Load duration	$R_{1,k} \times k_{mod}$		$R_{2/3,k} \times k_{mod}$		$R_{4/5,k} \times k_{mod}$	
	Flange A	Flange B		CNA Connector nail					
				4,0x40	4,0x60	4,0x40	4,0x60	4,0x40	4,0x60
Nailing pattern 1	5	5	S	2,6	4,0	3,7	5,5	e ≤ 0,40b+14: 3,2 e > 0,40b+14: <u>1,32b+36</u> e-2,0	e ≤ 0,70b+19: 3,2 e > 0,70b+19: <u>2,21b+52</u> e-2,0
			M	2,3	3,6	3,3	4,9	e ≤ 0,40b+14: 3,0 e > 0,40b+14: <u>1,18b+33</u> e-2,0	e ≤ 0,66b+19: 3,0 e > 0,66b+19: <u>1,96b+47</u> e-2,0

b and e are in mm

Factors for other load durations	$R_{1,k}$		$R_{2/3,k}$		$R_{4/5,k}$	
	CNA Connector nail					
	4,0x40	4,0x60	4,0x40	4,0x60	4,0x40	4,0x60
I multiply S by	1,19	1,20	1,22	1,22	1,10	1,10
L multiply M by	0,88	0,89	0,88	0,88	0,89	0,88
P multiply M by	0,75	0,78	0,75	0,75	0,77	0,76

Table D13-2 Modified characteristic capacity timber beam to timber beam – 1 Angle Bracket

1 Angle Bracket AA60280 per connection			Modified characteristic capacity per connection (kN)				
Nailing pattern	Number of fasteners		Load duration	$R_{1,k} \times k_{mod}$		$R_{2/3,k} \times k_{mod}$	
	Flange A	Flange B		CNA Connector nail			
				4,0x40	4,0x60	4,0x40	4,0x60
Nailing pattern 1	5	5	P	min: <u>37</u> f + 52 <u>12</u> f + 10	<u>12</u> f + 10	1,2	1,8
			L	min: <u>43</u> f + 52 <u>12</u> f + 10	<u>12</u> f + 10	1,4	2,1
			M	<u>12</u> f + 10	<u>12</u> f + 10	1,7	2,4
			S	<u>12</u> f + 10	<u>12</u> f + 10	1,9	2,7
			I	<u>12</u> f + 10	<u>12</u> f + 10	2,3	3,3

f is in mm



## Annex D14 – ABB40390

### Product Name:

Product Name	Material reference acc. to clause II-1	Alternative product names
ABB40390	Steel ref. 1	-
ABB40390S	Steel ref. 2	-
ABB40390S2	Steel ref. 3	-

### Connector Size Range:

Model no.	Dimensions [mm]				Holes flange A	Holes flange B
	A	B	C	Thickness	Ø5	Ø5
AA60280	93	93	40	3,0	5	5

### Drawing:

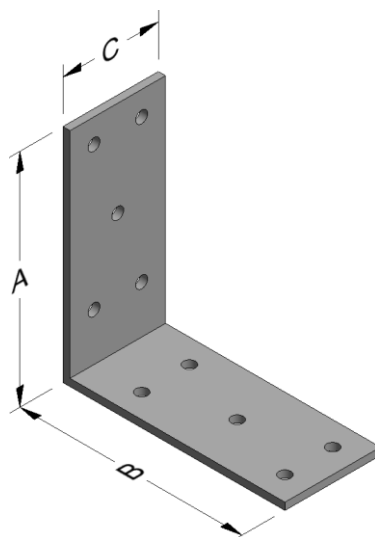

### Nailing pattern:

Nailing pattern 1

Nailing pattern 2

Flange A:



Flange B:

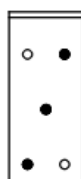
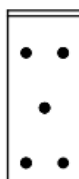

Beam to beam  
Maximum nailing

Beam to beam  
Minimum nailing

Table D14-1 Modified characteristic capacity timber beam to timber beam – 2 Angle Brackets

2 Angle Brackets ABB40390 per connection			Modified characteristic capacity per connection (kN)							
Nailing pattern	Number of fasteners		Load duration	$R_{1,k} \times k_{mod}$		$R_{2/3,k} \times k_{mod}$		$R_{4/5,k} \times k_{mod}$		
	Flange A	Flange B		CNA Connector nail						
				4,0x40	4,0x60	4,0x40	4,0x60	4,0x40	4,0x60	
Nailing pattern 2	3	3	S	1,9	2,8	1,5	2,0	e ≤ 0,21b+14: 4,5 e > 0,21b+14: <u>0,96b+48</u> e-3,0	e ≤ 0,30b+15: 4,6 e > 0,30b+15: <u>1,38b+57</u> e-3,0	
			M	1,8	2,5	1,4	1,8	e ≤ 0,24b+16: 3,6 e > 0,24b+16: <u>0,88b+46</u> e-3,0	e ≤ 0,29b+16: 4,3 e > 0,29b+16: <u>1,26b+54</u> e-3,0	
Nailing pattern 1	3	5	S	2,7	4,4	1,8	2,5	e ≤ 0,32b+16: 4,5 e > 0,32b+16: <u>1,46b+59</u> e-3,0	e ≤ 0,49b+19: 4,6 e > 0,49b+19: <u>2,22b+75</u> e-3,0	
			M	2,4	3,9	1,6	2,2	e ≤ 0,37b+18: 3,6 e > 0,37b+18: <u>1,34b+56</u> e-3,0	e ≤ 0,47b+19: 4,3 e > 0,47b+19: <u>2,01b+71</u> e-3,0	

b and e are in mm

Factors for other load durations	$R_{1,k}$		$R_{2/3,k}$		$R_{4/5,k}$	
	CNA Connector nail					
	4,0x40	4,0x60	4,0x40	4,0x60	4,0x40	4,0x60
I multiply S by	1,15	1,00	1,22	1,22	1,10	1,06
L multiply M by	0,88	0,88	0,88	0,88	0,84	0,90
P multiply M by	0,75	0,75	0,75	0,75	0,78	0,80

Table D14-2 Modified characteristic capacity timber beam to timber beam – 1 Angle Bracket

1 Angle Bracket ABB40390 per connection			Modified characteristic capacity per connection (kN)				
Nailing pattern	Number of fasteners		Load duration	$R_{1,k} \times k_{mod}$ Upper member may rotate		$R_{2/3,k} \times k_{mod}$	
	Flange A	Flange B		CNA Connector nail			
				4,0x40	4,0x60	4,0x40	4,0x60
Nailing pattern 2	3	3	P	$\frac{14}{f + 53}$	min: $\frac{24}{f + 53}$ $\frac{20}{f + 21}$	0,5	0,7
			L	$\frac{17}{f + 53}$	min: $\frac{28}{f + 53}$ $\frac{20}{f + 21}$	0,6	0,8
			M	$\frac{19}{f + 53}$	min: $\frac{31}{f + 53}$ $\frac{20}{f + 21}$	0,7	0,9
			S	min: $\frac{21}{f + 53}$ $\frac{20}{f + 21}$	min: $\frac{35}{f + 53}$ $\frac{20}{f + 21}$	0,8	1,0
			I	min: $\frac{26}{f + 53}$ $\frac{20}{f + 21}$	min: $\frac{43}{f + 53}$ $\frac{20}{f + 21}$	0,9	1,2

Table D14-3 Modified characteristic capacity timber beam to timber beam – 1 Angle Bracket

1 Angle Bracket ABB40390 per connection			Modified characteristic capacity per connection (kN)				
Nailing pattern	Number of fasteners		Load duration	$R_{1,k} \times k_{mod}$		$R_{2/3,k} \times k_{mod}$	
	Flange A	Flange B		CNA Connector nail			
				4,0x40	4,0x60	4,0x40	4,0x60
Nailing pattern 1	3	5	P	min: $\frac{28}{f + 53}$ $\frac{20}{f + 21}$	$\frac{20}{f + 21}$	0,6	0,8
			L	min: $\frac{33}{f + 53}$ $\frac{20}{f + 21}$	$\frac{20}{f + 21}$	0,7	1,0
			M	$\frac{20}{f + 21}$	$\frac{20}{f + 21}$	0,8	1,1
			S	$\frac{20}{f + 21}$	$\frac{20}{f + 21}$	0,9	1,2
			I	$\frac{20}{f + 21}$	$\frac{20}{f + 21}$	1,1	1,5

## Annex D15 – AE48

### Product Name:

Product Name	Material reference acc. to clause II-1	Alternative product names
AE48	Steel ref. 1	France: EB/7048
AE48S	Steel ref. 2	-
AE48S2	Steel ref. 3	-

### Connector Size Range:

Model no.	Dimensions [mm]				Holes flange A		Holes flange B	
	A	B	C	Thickness	Ø5	Ø13	Ø5	Ø13
AE48	90	48	48	3,0	7	2	4	1

### Drawing:

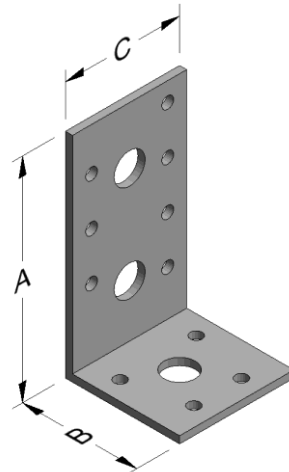

### Nailing pattern:

Nailing pattern 1      Nailing pattern 2      Nailing pattern 3      Nailing pattern 4      Nailing pattern 5

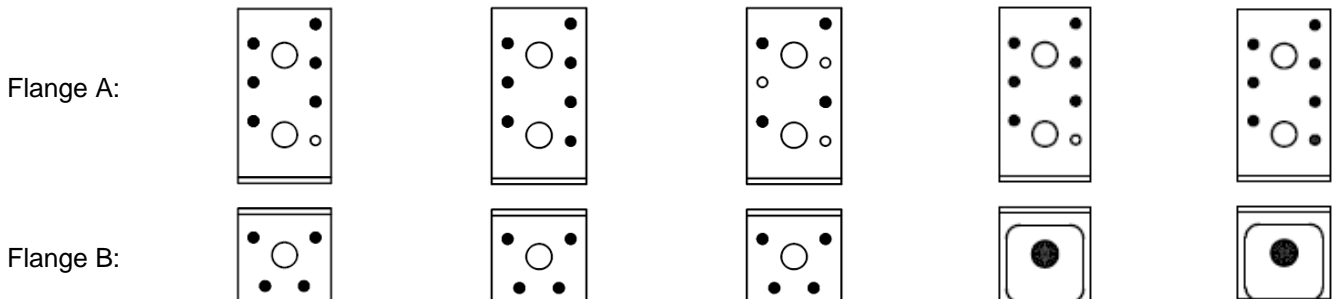

Nailing pattern	No of fasteners		Description
	Flange A	Flange B	
1	6	4	Max. nailing with force F1 , F2, F3, F4 and F5
2	7	4	Max. nailing with force F2 and F3
3	4	4	Min. nailing with force F1 , F2, F3, F4 and F5
4	6	1 x M12	Max. nailing with force F1 , F2, F3, F4 and F5
5	7	1 x M12	Max. nailing with force F2 and F3

Square washer (US40/40/10G or US40/50/10G) can be replaced by standard washer of the bolts (bolt Ø12 – washer Ø24). In this case, the value of  $k_{lat}$  and  $k_{ax}$  must be adapted (see tables below D15-4 and D15-5).

Table D15-1 Modified characteristic capacity timber beam to timber beam – 2 Angle Brackets

2 Angle Brackets AE48 per connection			Modified characteristic capacity per connection (kN)						
Nailing pattern	Number of fasteners		Load duration	$R_{1,k} \times k_{mod}$		$R_{2/3,k} \times k_{mod}$		$R_{4/5,k} \times k_{mod}$ (Minimum between values)	
	Flange A	Flange B		CNA Connector nail					
				4.0x40	4.0x60	4.0x40	4.0x60	4.0x40	4.0x60
Nailing pattern 1	6	4	P	1,8	2,9	2,4	3,6	3,39 <u>0.88b+38</u> e-3	3,39 <u>1.47b+42</u> e-3
			L	2,1	3,4	2,8	4,2	3,66 <u>1.03b+39</u> e-3	3,66 <u>1.72b+44</u> e-3
			M	2,4	3,9	3,2	4,8	3,91 <u>1.18b+40</u> e-3	4,04 <u>1.96b+46</u> e-3
			S	2,6	4,4	3,6	5,4	4,15 <u>1.32b+41</u> e-3	5,29 <u>2.21b+47</u> e-3
			I	3,2	5,4	4,4	6,6	5,36 <u>1.62b+43</u> e-3	5,85 <u>2.70b+51</u> e-3
Nailing Pattern 2	7	4	P	-	-	2,4	3,7	-	-
			L	-	-	2,8	4,3	-	-
			M	-	-	3,2	4,9	-	-
			S	-	-	3,6	5,5	-	-
			I	-	-	4,5	6,8	-	-
Nailing Pattern 3	4	4	P	1,8	2,9	2,4	3,3	3,39 <u>0.88b+38</u> e-3	3,39 <u>1.47b+42</u> e-3
			L	2,1	3,4	2,8	3,8	3,66 <u>1.03b+39</u> e-3	3,66 <u>1.72b+44</u> e-3
			M	2,4	3,9	3,2	4,4	3,91 <u>1.18b+40</u> e-3	4,04 <u>1.96b+46</u> e-3
			S	2,6	4,4	3,6	4,9	4,15 <u>1.32b+41</u> e-3	5,29 <u>2.21b+47</u> e-3
			I	3,2	5,4	4,3	6	5,36 <u>1.62b+43</u> e-3	5,85 <u>2.70b+51</u> e-3

Table D15-2 Modified characteristic capacity timber beam to timber beam – 1 Angle Bracket

1 Angle Brackets AE48 per connection				Modified characteristic capacity			
Nailing pattern	Number of fasteners		Load duration	$R_{1,k} \times k_{mod}$ (Minimum between values - Purlin may rotate)		$R_{2/3,k} \times k_{mod}$	
	Flange A	Flange B		CNA Connector nail			
				4.0x40	4.0x60	4.0x40	4.0x60
Nailing pattern 1	6	4	P	24/(f+40)	40/(f+40)	1,2	1,8
				25/(f+13)	25/(f+13)		
			L	28/(f+40)	46/(f+40)	1,4	2,1
				25/(f+13)	25/(f+13)		
			M	32/(f+40)	53/(f+40)	1,6	2,4
				25/(f+13)	25/(f+13)		
S	36/(f+40)	60/(f+40)	1,8	2,7			
	25/(f+13)	25/(f+13)					
I	44/(f+40)	25/(f+13)	2,2	3,3			
	25/(f+13)						
Nailing Pattern 2	7	4	P	-	-	1,2	1,8
				L	-		
			M	-	-	1,6	2,5
				S	-		
			I	-	-	2,2	3,4
Nailing Pattern 3	4	4	P	24/(f+40)	40/(f+40)		
				25/(f+13)	25/(f+13)		
			L	28/(f+40)	46/(f+40)	1,4	1,9
				25/(f+13)	25/(f+13)		
			M	32/(f+40)	53/(f+40)	1,6	2,2
				25/(f+13)	25/(f+13)		
S	36/(f+40)	60/(f+40)	1,8	2,5			
	25/(f+13)	25/(f+13)					
I	44/(f+40)	25/(f+13)	2,2	3			
	25/(f+13)						

**Table D15-3 Modified characteristic capacity timber beam to rigid support – 2 Angle Brackets**

2 Angle Brackets AE48 per connection			Modified characteristic capacity						
Nailing pattern	Number of fasteners		Load duration	$R_{1,k} \times k_{mod}$		$R_{2/3,k} \times k_{mod}$		$R_{4/5,k} \times k_{mod}$ (Minimum between values)	
	Flange A	Flange B		CNA Connector nail					
				4.0x40	4.0x60	4.0x40	4.0x60	4.0x40	4.0x60
Nail pattern 4	6	1 Bolt Ø12	P	4,4	7,1	1,3	2,1	3,39	3,39
				8,9	12,6			$\frac{4.45b+63}{e-3}$	$\frac{6.28b+76}{e-3}$
			L	5,2	8,3	1,5	2,5	3,66	3,66
				10,5	12,6			$\frac{5.23b+68}{e-3}$	$\frac{6.28b+76}{e-3}$
			M	5,9	9,5	1,7	2,8	3,91	3,91
				11,9	12,6			$\frac{5.95b+73}{e-3}$	$\frac{6.28b+76}{e-3}$
			S	6,6	10,6	1,9	3,2	4,15	4,89
				12,6	12,6			$\frac{6.28b+76}{e-3}$	$\frac{6.28b+76}{e-3}$
			I	8,1	10,6	2,4	3,9	4,82	5,96
				12,6	12,6			$\frac{6.28b+76}{e-3}$	$\frac{6.28b+76}{e-3}$
Nail Pattern 5	7	1 Bolt Ø12	P	-	-	1,3	2,1	-	-
			L	-	-	1,5	2,5	-	-
			M	-	-	1,7	2,8	-	-
			S	-	-	1,9	3,2	-	-
			I	-	-	2,4	3,9	-	-

e and b are in [mm]

When the purlin has a wane on the side towards the Angle Bracket the value in the grey square is valid.

AE48	connection with 2 angle brackets			
factor:	for $F_1$	for $F_{2/3}$	for $F_{4/5}$ , bolt 1	for $F_{4/5}$ , bolt 2
$k_{ax}$ square washer	0,62	-	$1,24 \times \frac{e}{(b+7)}$	-
$k_{lat}$ square washer	-	0,50	-	1,00
$k_{ax}$ round washer	0,66	-	$1,33 \times \frac{e}{(b+7)}$	-
$k_{lat}$ round washer	-	0,50	-	1,00

e and b are in [mm]

For each bolt (bolt group) it's needed to check:

$R_{bolt,d,lateral} \geq k_{lat} \times F_{i,d}$  ;  $R_{bolt,d,axial} \geq k_{ax} \times F_{i,d}$  ; and also the combination

Square washer = US40/40/10G or US40/50/10G

Round washer = standard washer of the anchor bolt. For anchor Ø12 the washer diameter is Ø24



**Table D15-4 Modified characteristic capacity timber beam to rigid support – 1 Angle Bracket**

1 Angle Bracket AE48 per connection			Modified characteristic capacity				
Nailing pattern	Number of fasteners		Load duration	$R_{1,k} \times k_{mod}$ (Purlin may rotate)		$R_{2/3,k} \times k_{mod}$	
	Flange A	Flange B		CNA Connector nail			
				4.0x40	4.0x60	4.0x40	4.0x60
Nail pattern 4	6	1 Bolt Ø12	P	20/(f+9)	20/(f+9)	0,6	1,1
			L	20/(f+9)	20/(f+9)	0,7	1,2
			M	20/(f+9)	20/(f+9)	0,9	1,4
			S	20/(f+9)	20/(f+9)	1	1,6
			I	20/(f+9)	20/(f+9)	1,2	2
Nail Pattern 5	7	1 Bolt Ø12	P	-	-	0,6	1,1
			L	-	-	0,7	1,2
			M	-	-	0,9	1,4
			S	-	-	1	1,6
			I	-	-	1,2	2

f is in [mm]

When the purlin has a wane on the side towards the Angle Bracket the value in the grey square is valid.

AE48	connection with 1 angle brackets	
factor:	for $F_1$	for $F_{2/3}$
$k_{ax}$ square	$(f+48)/27$	2,08
$k_{lat}$ square	-	1,00
$k_{ax}$ round	$(f+48)/27$	2,08
$k_{lat}$ round	-	1,00

f is in [mm]

For each bolt (bolt group) it's needed to check:

$R_{bolt,d,lateral} \geq k_{lat} \times F_{i,d}$  ;  $R_{bolt,d,axial} \geq k_{ax} \times F_{i,d}$  ; and also the combination

Square washer = US40/40/10G or US40/50/10G

Round washer = standard washer of the anchor bolt. For anchor Ø12 the washer diameter is Ø24

## Annex D16 – AE76

### Product Name:

Product Name	Material reference acc. to clause II-1	Alternative product names
AE76	Steel ref. 1	France: EB/7076
AE76S	Steel ref. 2	-
AE76S2	Steel ref. 3	-

### Connector Size Range:

Model no.	Dimensions [mm]				Holes flange A		Holes flange B	
	A	B	C	Thickness	Ø5	Ø13	Ø5	Ø13
AE76	90	48	76	3,0	12	3	7	1

### Drawing:

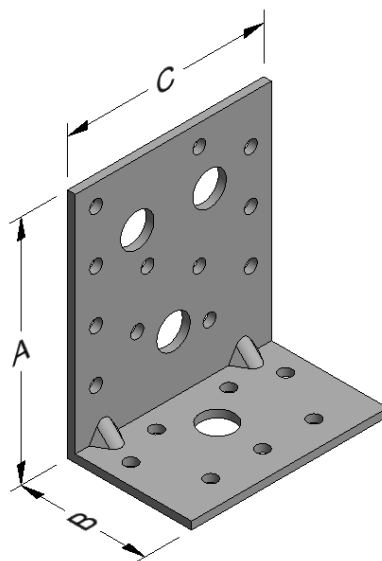

**Nailing pattern:**

Nailing pattern 1

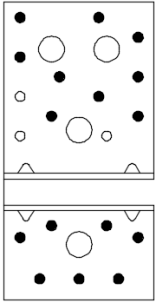

Nailing pattern 2

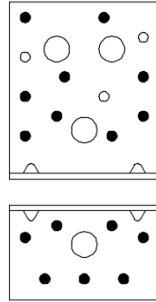

Nailing pattern 3

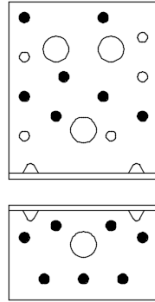

Nailing pattern 4

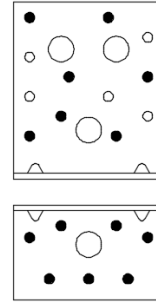

Nailing pattern 5

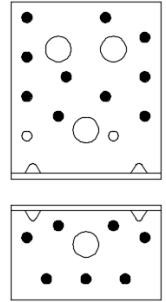

Nailing pattern 6

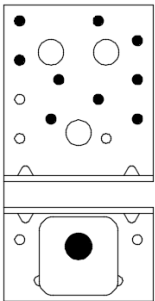

Nailing pattern 7

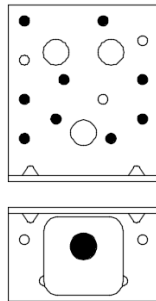

Nailing pattern 8

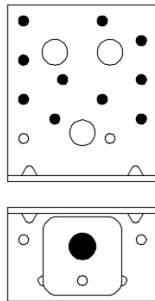

Square washer (US40/40/10G or US40/50/10G) can be replaced by standard washer of the bolts (bolt Ø12 – washer Ø24). In this case, the value of  $k_{lat}$  and  $k_{ax}$  must be adapted (see tables below D16-4 and D16-5).

Nailing pattern	No of fasteners		Description
	Flange A	Flange B	
1	9	7	Nailing with force F1 , F2, F3, F4 and F5
2	9	7	Max. nailing with force F2 and F3
3	7	7	Min. nailing with force F1 , F2, F3, F4 and F5
4	7	7	Min. nailing with force F2 and F3
5	10	7	Nailing with force F1 , F2, F3, F4 and F5
6	9	1 x M12	Max. nailing with force F1 , F2, F3, F4 and F5
7	9	1 x M12	Max. nailing with force F2 and F3
8	10	1 x M12	Max. nailing with force F1 , F2, F3, F4 and F5

Table D16-1 Modified characteristic capacity timber beam to timber beam – 2 Angle Brackets

2 Angle Brackets AE76 per connection				Modified characteristic capacity (kN)					
Nailing pattern	Number of fasteners		Load duration	$R_{1,k} \times k_{mod}$		$R_{2/3,k} \times k_{mod}$		$R_{4/5,k} \times k_{mod}$ (Minimum between values)	
	Flange A	Flange B		CNA Connector nail					
				4.0x40	4.0x60	4.0x40	4.0x60	4.0x40	4.0x60
Nailing pattern 1	9	7	P	3,5	5,9	7	9,4	7 <u>1.76b+98</u> e-3	7 <u>2.94b+107</u> e-3
			L	4,1	6,9	8,1	11	7,56 <u>2.06b+100</u> e-3	7,56 <u>3.43b+110</u> e-3
			M	4,7	7,8	9,3	12,5	8,09 <u>2.35b+102</u> e-3	8,09 <u>3.92b+113</u> e-3
			S	5,3	8,8	10,4	14,1	8,58 <u>2.65b+105</u> e-3	8,58 <u>4.41b+117</u> e-3
			I	6,5	10,8	12,8	17,2	9,48 <u>3.24b+109</u> e-3	11,25 <u>5.39b+124</u> e-3
Nailing Pattern 2	9	7	P	-	-	7,2	10,4	-	-
			L	-	-	8,4	12,2	-	-
			M	-	-	9,6	13,9	-	-
			S	-	-	10,8	15,6	-	-
			I	-	-	13,2	19,1	-	-
Nailing Pattern 3	7	7	P	3,5	5,9	5,7	7,9	7 <u>1.76b+98</u> e-3	7 <u>2.94b+107</u> e-3
			L	4,1	6,9	6,7	9,2	7,56 <u>2.06b+100</u> e-3	7,56 <u>3.43b+110</u> e-3
			M	4,7	7,8	7,6	10,5	8,09 <u>2.35b+102</u> e-3	8,09 <u>3.92b+113</u> e-3
			S	5,3	8,8	8,6	11,8	8,58 <u>2.65b+105</u> e-3	8,58 <u>4.41b+117</u> e-3
			I	6,5	10,8	10,5	14,5	9,48 <u>3.24b+109</u> e-3	9,48 <u>5.39b+124</u> e-3
Nailing Pattern 4	7	7	P	-	-	6,3	8,6	-	-
			L	-	-	7,3	10	-	-
			M	-	-	8,4	11,4	-	-
			S	-	-	9,4	12,9	-	-
			I	-	-	11,5	15,7	-	-
Nailing Pattern 5	10	3	P	3,53		7,3	10,1	7 <u>1.76b+98</u> e-3	7 <u>2.94b+107</u> e-3
			L	4,12		8,5	11,8	7,56 <u>2.06b+100</u> e-3	7,56 <u>3.43b+110</u> e-3
			M	4,7		9,7	13,4	8,09 <u>2.35b+102</u> e-3	8,09 <u>3.92b+113</u> e-3
			S	5,3		10,9	15,1	8,58 <u>2.65b+105</u> e-3	8,58 <u>4.41b+117</u> e-3
			I	6,5		13,4	18,5	9,48 <u>3.24b+109</u> e-3	11,25 <u>5.39b+124</u> e-3

b and e are in [mm]

Table D16-2 Modified characteristic capacity timber beam to timber beam – 1 Angle Bracket

1 Angle Bracket AE76 per connection				Modified characteristic capacity (kN)			
Nailing pattern	Number of fasteners		Load duration	$R_{1,k} \times k_{mod}$ (Minimum between values - Purlin may rotate)		$R_{2/3,k} \times k_{mod}$	
	Flange A	Flange B		CNA Connector nail			
				4.0x40	4.0x60	4.0x40	4.0x60
Nailing pattern 1	9	7	P	42/(f+40)	69/(f+40)	3,5	4,7
				35/(f+8.5)	35/(f+8.5)		
			L	49/(f+40)	81/(f+40)	4,1	5,5
				35/(f+8.5)	35/(f+8.5)		
			M	56/(f+40)	93/(f+40)	4,6	6,3
				35/(f+8.5)	35/(f+8.5)		
			S	63/(f+40)	104/(f+40)	5,2	7,1
				35/(f+8.5)	35/(f+8.5)		
			I	76/(f+40)	127/(f+40)	6,4	8,6
				35/(f+8.5)	35/(f+8.5)		
Nailing Pattern 2	9	7	P	-	-	3,6	5,2
			L	-	-	4,2	6,1
			M	-	-	4,8	7
			S	-	-	5,4	7,8
			I	-	-	6,6	9,6
Nailing Pattern 3	7	7	P	42/(f+40)	69/(f+40)	2,9	3,9
				35/(f+8.5)	35/(f+8.5)		
			L	49/(f+40)	81/(f+40)	3,3	4,6
				35/(f+8.5)	35/(f+8.5)		
			M	56/(f+40)	93/(f+40)	3,8	5,3
				35/(f+8.5)	35/(f+8.5)		
			S	63/(f+40)	104/(f+40)	4,3	5,9
				35/(f+8.5)	35/(f+8.5)		
			I	76/(f+40)	127/(f+40)	5,2	7,2
				35/(f+8.5)	35/(f+8.5)		
Nailing Pattern 4	7	7	P	-	-	3,1	4,3
			L	-	-	3,7	5
			M	-	-	4,2	5,7
			S	-	-	4,7	6,4
			I	-	-	5,8	7,9
Nailing Pattern 5	10	3	P	42/(f+40)	69/(f+40)	3,6	5
				35/(f+8.5)	35/(f+8.5)		
			L	49/(f+40)	81/(f+40)	4,3	5,9
				35/(f+8.5)	35/(f+8.5)		
			M	56/(f+40)	93/(f+40)	4,9	6,7
				35/(f+8.5)	35/(f+8.5)		
			S	63/(f+40)	104/(f+40)	5,5	7,6
				35/(f+8.5)	35/(f+8.5)		
			I	76/(f+40)	127/(f+40)	6,7	9,2
				35/(f+8.5)	35/(f+8.5)		

f is in [mm]

Table D16-3 Modified characteristic capacity timber beam to rigid support – 2 Angle Brackets

2 Angle Brackets AE76 per connection			Modified characteristic capacity (kN)						
Nailing pattern	Number of fasteners		Load duration	$R_{1,k} \times k_{mod}$		$R_{2/3,k} \times k_{mod}$		$R_{4/5,k} \times k_{mod}$ (Minimum between values)	
	Flange A	Flange B		CNA Connector nail					
				4.0x40	4.0x60	4.0x40	4.0x60	4.0x40	4.0x60
Nailing pattern 6	9	1 Bolt Ø12	P	4,8	7,9	4,5	6,7	7	7
				13,6	16,8			$\frac{6.81b+134}{e-3}$	$\frac{8.41b+145}{e-3}$
			L	5,7	9,2	5,3	7,8	7,56	7,56
				16,0	16,8			$\frac{7.99b+142}{e-3}$	$\frac{8.41b+145}{e-3}$
			M	6,4	10,5	6,1	8,9	8,09	8,09
				16,8	16,8			$\frac{8.41b+145}{e-3}$	$\frac{8.41b+145}{e-3}$
			S	7,2	11,7	6,8	10	8,58	8,58
				16,8	16,8			$\frac{8.41b+145}{e-3}$	$\frac{8.41b+145}{e-3}$
			I	8,8	14,4	8,3	12,3	9,48	9,48
				16,8	16,8			$\frac{8.41b+145}{e-3}$	$\frac{8.41b+145}{e-3}$
Nailing Pattern 7	9	1 Bolt Ø12	P	-	-	4,6	7,1	-	-
			L	-	-	5,3	8,2	-	-
			M	-	-	6,1	9,4	-	-
			S	-	-	6,9	10,6	-	-
			I	-	-	8,4	12,9	-	-
Nailing Pattern 8	10	1 Bolt Ø12	P	4,8	7,9	4,6	7,6	7	7
				13,6	16,8			$\frac{6.81b+134}{e-3}$	$\frac{8.41b+145}{e-3}$
			L	5,7	9,2	5,3	8,9	7,56	7,56
				16,0	16,8			$\frac{7.99b+142}{e-3}$	$\frac{8.41b+145}{e-3}$
			M	6,4	10,5	6,1	10,2	8,09	8,09
				16,8	16,8			$\frac{8.41b+145}{e-3}$	$\frac{8.41b+145}{e-3}$
			S	7,2	11,7	6,9	11,5	8,58	8,58
				16,8	16,8			$\frac{8.41b+145}{e-3}$	$\frac{8.41b+145}{e-3}$
			I	8,8	14,4	8,4	14	9,48	9,48
				16,8	16,8			$\frac{8.41b+145}{e-3}$	$\frac{8.41b+145}{e-3}$

e and b are in [mm]

When the purlin has a wane on the side towards the Angle Bracket the value in the grey square is valid.

AE76	Connection with 2 Angle Brackets			
factor:	for $F_1$	for $F_{2/3}$	for $F_{4/5, \text{bolt 1}}$	for $F_{4/5, \text{bolt 2}}$
$k_{ax}$ square washer	0,54	-	$1,08 \times \frac{e}{(b+7)}$	-
$k_{lat}$ square washer	-	0,5	-	1,00
$k_{ax}$ round washer	0,58	-	$1,16 \times \frac{e}{(b+7)}$	-
$k_{lat}$ round washer	-	0,5	-	1,00

e and b are in [mm]

For each bolt (bolt group) it's needed to check:

 $R_{\text{bolt},d,\text{lateral}} \geq k_{\text{lat}} \times F_{i,d}$  ;  $R_{\text{bolt},d,\text{axial}} \geq k_{\text{ax}} \times F_{i,d}$  ; and also the combination

Square washer = US40/40/10G or US40/50/10G

Round washer = standard washer of the anchor bolt. For anchor Ø12 the washer diameter is Ø24

Table D16-4 Modified characteristic capacity timber beam to rigid support – 1 Angle Bracket

1 Angle Bracket AE76 per connection			Modified characteristic capacity (kN)				
Nailing pattern	Number of fasteners		Load duration	$R_{1,k} \times k_{mod}$ (Purlin may rotate)		$R_{2/3,k} \times k_{mod}$	
	Flange A	Flange B		CNA Connector nail			
				4.0x40	4.0x60	4.0x40	4.0x60
Nailing pattern 6	9	1 Bolt Ø12	P	34/(f+5)	34/(f+5)	2,3	3,3
			L	34/(f+5)	34/(f+5)	2,7	3,9
			M	34/(f+5)	34/(f+5)	3	4,5
			S	34/(f+5)	34/(f+5)	3,4	5
			I	34/(f+5)	34/(f+5)	4,2	6,1
Nailing Pattern 7	9	1 Bolt Ø12	P	-	-	2,3	3,5
			L	-	-	2,7	4,1
			M	-	-	3	4,7
			S	-	-	3,4	5,3
			I	-	-	4,2	6,5
Nailing Pattern 8	10	1 Bolt Ø12	P	34/(f+5)	34/(f+5)	2,3	3,8
			L	34/(f+5)	34/(f+5)	2,7	4,5
			M	34/(f+5)	34/(f+5)	3	5,1
			S	34/(f+5)	34/(f+5)	3,4	5,7
			I	34/(f+5)	34/(f+5)	4,2	7

f is in [mm]

AE76	Connection with 1 Angle Bracket	
factor:	for $F_1$	for $F_{2/3}$
$k_{ax}$ square washer	(f+45)/28	0,74
$k_{lat}$ square washer	-	1
$k_{ax}$ round washer	(f+45)/28	0,74
$k_{lat}$ round washer	-	1

f is in [mm]

For each bolt (bolt group) it's needed to check:

 $R_{bolt,d,lateral} \geq k_{lat} \times F_{i,d}$  ;  $R_{bolt,d,axial} \geq k_{ax} \times F_{i,d}$  ; and also the combination

Square washer = US40/40/10G or US40/50/10G

Round washer = standard washer of the anchor bolt. For anchor Ø12 the washer diameter is Ø24

## Annex D17 – AE116

### Product Name:

Product Name	Material reference acc. to clause II-1	Alternative product names
AE116	Steel ref. 1	-
AE116S	Steel ref. 2	-
AE116S2	Steel ref. 3	-

### Connector Size Range:

Model no.	Dimensions [mm]				Holes flange A		Holes flange B	
	A	B	C	Thickness	Ø5	Ø13	Ø5	Ø13
AE116	90	48	116	3,0	18	3	7	3

### Drawing:

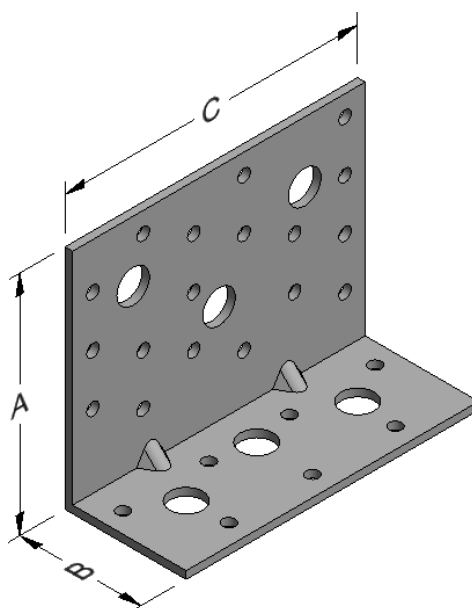



**Nailing pattern:**

Nailing pattern 1

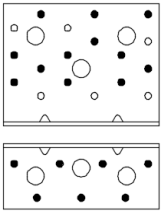

Nailing pattern 2

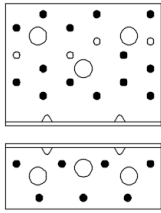

Nailing pattern 3

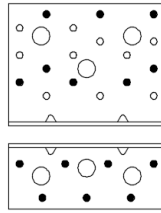

Nailing pattern 4

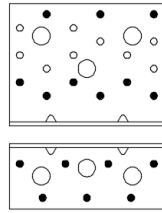

Nailing pattern 5

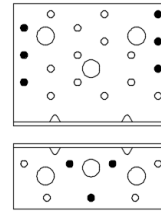

Nailing pattern 6

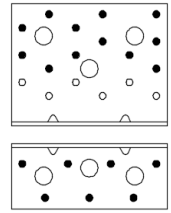

Nailing pattern 7

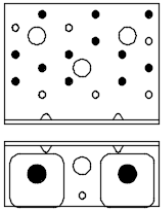

Nailing pattern 8

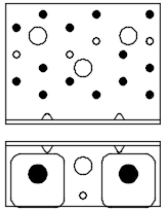

Nailing pattern 9

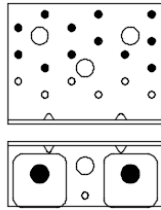

Square washer (US40/40/10G or US40/50/10G) can be replaced by standard washer of the bolts (bolt Ø12 – washer Ø24). In this case, the value of  $k_{lat}$  and  $k_{ax}$  must be adapted (see tables below D17-4 and D17-5).

Nailing pattern	No of fasteners		Description
	Flange A	Flange B	
1	12	7	Nailing with force F1 , F2, F3, F4 and F5
2	14	7	Max. nailing with force F2 and F3
3	8	7	Min. nailing with force F1 , F2, F3, F4 and F5
4	9	7	Min. nailing with force F2, F3
5	6	3	Specific nailing for timber beam to rafter connection
6	12	7	Nailing with force F1, F2 and F3
7	12	2 x M12	Max. nailing with force F1 , F2, F3 F4 and F5
8	14	2 x M12	Max. nailing with force F2 and F3
9	12	2 x M12	Nailing with force F1, F2 and F3

Table D17-1 Modified characteristic capacity timber beam to timber beam – 2 Angle Brackets

2 Angle Brackets AE116 per connection			Modified characteristic capacity (kN)						
Nailing pattern	Number of fasteners		Load duration	$R_{1,k} \times k_{mod}$		$R_{2/3,k} \times k_{mod}$		$R_{4/5,k} \times k_{mod}$ (Minimum between values)	
	Flange A	Flange B		CNA Connector nail					
				4.0x40	4.0x60	4.0x40	4.0x60	4.0x40	4.0x60
Nailing pattern 1	12	7	P	3,5	5,9	9,9	13,9	7,6 <u>1.76b+139</u> e-3	9,9 <u>2.94b+147</u> e-3
			L	4,1	6,9	11,6	16,2	8,9 <u>2.06b+141</u> e-3	11,3 <u>3.43b+150</u> e-3
			M	4,7	7,8	13,2	18,5	10,1 <u>2.35b+143</u> e-3	12,1 <u>3.92b+154</u> e-3
			S	5,3	8,8	14,9	20,8	11,4 <u>2.65b+145</u> e-3	12,8 <u>4.41b+157</u> e-3
			I	6,5	10,8	18,2	25,5	13,9 <u>3.24*149</u> e-3	17,6 <u>5.39b+164</u> e-3
Nailing Pattern 2	14	7	P	-	-	11,5	16	-	-
			L	-	-	13,4	18,6	-	-
			M	-	-	15,3	21,3	-	-
			S	-	-	17,2	23,9	-	-
			I	-	-	21	29,2	-	-
Nailing Pattern 3	8	7	P	3,5	5,9	8,3	11,6	7,6 <u>1.76b+139</u> e-3	9,9 <u>2.94b+147</u> e-3
			L	4,1	6,9	9,7	13,5	8,9 <u>2.06b+141</u> e-3	11,3 <u>3.43b+150</u> e-3
			M	4,7	7,8	11	15,5	10,1 <u>2.35b+143</u> e-3	12,1 <u>3.92b+154</u> e-3
			S	5,3	8,8	12,4	17,4	11,4 <u>2.65b+145</u> e-3	12,8 <u>4.41b+157</u> e-3
			I	6,5	10,8	15,2	21,3	13,9 <u>3.24*149</u> e-3	17,6 <u>5.39b+164</u> e-3
Nailing Pattern 4	9	7	P			10	13,6	-	-
			L			11,6	15,9	-	-
			M			13,3	18,2	-	-
			S			15	20,4	-	-
			I			18,3	25	-	-
Nailing Pattern 6			P	3,5	5,9	9,6	12,8	-	-
			L	4,1	6,9	11,2	14,9	-	-
			M	4,7	7,8	12,8	17,1	-	-
			S	5,3	8,8	14,4	19,2	-	-
			I	6,5	10,8	17,6	23,5	-	-

Table D17-2 Modified characteristic capacity timber beam to timber beam – 1 Angle Bracket

1 Angle Brackets AE116 per connection			Modified characteristic capacity (kN)				
Nailing pattern	Number of fasteners		Load duration	$R_{1,k} \times k_{mod}$ (Minimum between values - Purlin may rotate)		$R_{2/3,k} \times k_{mod}$	
	Flange A	Flange B		CNA Connector nail			
				4.0x40	4.0x60	4.0x40	4.0x60
Nailing pattern 1	12	7	P	48/(f+40)	79/(f+40)	5	6,9
				42/(f+13)	42/(f+13)		
			L	56/(f+40)	93/(f+40)	5,8	8,1
				42/(f+13)	42/(f+13)		
			M	64/(f+40)	106/(f+40)	6,6	9,3
S	42/(f+13)	42/(f+13)	7,4	10,4			
Nailing Pattern 2	14	7	P	-	-	5,7	8
				L	-		
			M	-	-	7,6	10,6
			S	-	-	8,6	12
			I	-	-	10,5	14,6
Nailing Pattern 3	8	7	P	48/(f+40)	79/(f+40)	4,1	5,8
				42/(f+13)	42/(f+13)		
			L	56/(f+40)	93/(f+40)	4,8	6,8
				42/(f+13)	42/(f+13)		
			M	64/(f+40)	106/(f+40)	5,5	7,7
S	42/(f+13)	42/(f+13)	6,2	8,7			
Nailing Pattern 4	9	7	P	-	-	5	6,8
				L	-		
			M	-	-	6,6	9,1
			S	-	-	7,5	10,2
			I	-	-	9,1	12,5
Nailing Pattern 6			P	48/(f+40)	79/(f+40)	4,8	6,4
				42/(f+13)	42/(f+13)		
			L	56/(f+40)	93/(f+40)	5,6	7,5
				42/(f+13)	42/(f+13)		
			M	64/(f+40)	106/(f+40)	6,4	8,5
S	42/(f+13)	42/(f+13)	7,2	9,6			
I	87/(f+40)	42/(f+13)	8,8	11,7			
	42/(f+13)						

Table D17-3 Modified characteristic capacity timber beam to rigid support connection - 2 Angle Brackets

2 Angle Brackets AE116 per connection			Modified characteristic capacity						
Nailing pattern	Number of fasteners		Load duration	$R_{1,k} \times k_{mod}$		$R_{2/3,k} \times k_{mod}$		$R_{4/5,k} \times k_{mod}$ (Minimum between values)	
	Flange A	Flange B		CNA Connector nail					
				4.0x40	4.0x60	4.0x40	4.0x60	4.0x40	4.0x60
Nailing pattern 7	12	2 Bolts Ø12	P	5,6	9,3	15,5	16,7	10,5	10,5
				15,1	23,0			$\frac{7.5b+179}{e-3}$	$\frac{11.5b+207}{e-3}$
			L	6,6	10,8	18,1	19,4	11,3	11,3
				17,8	26,7			$\frac{8.9b+188}{e-3}$	$\frac{13.3b+220}{e-3}$
			M	7,5	12,3	20,7	22,2	12,1	12,1
				20,2	28,1			$\frac{10.1b+197}{e-3}$	$\frac{14b+225}{e-3}$
S	8,4	13,8	23,3	25	12,8	12,8			
	22,6	28,1			$\frac{11.3b+206}{e-3}$	$\frac{14b+225}{e-3}$			
I	10,3	16,9	28,4	30,5	14,2	17,6			
	27,7	28,1			$\frac{13.9b+223}{e-3}$	$\frac{14b+225}{e-3}$			
Nailing Pattern 8	14	2 Bolts Ø12	P	-	-	16,5	17,1	-	-
			L	-	-	19,2	19,9	-	-
			M	-	-	22	22,8	-	-
			S	-	-	24,7	25,6	-	-
			I	-	-	30,2	31,3	-	-
Nailing Pattern 9	12	2 Bolts Ø12	P	8,6	13,9	14,8	16,3	-	-
				17,1	25,4			-	-
			L	10,1	16,2	17,2	19,1	-	-
				20,1	28,1			-	-
			M	11,5	18,5	19,7	21,8	-	-
				22,9	28,1			-	-
S	12,9	20,8	22,1	24,5	-	-			
	25,6	28,1			-	-			
I	15,8	25,5	27,1	30	-	-			
28,1	28,1	-			-				

e and b are in [mm]

When the purlin has a wane on the side towards the Angle Bracket the value in the grey square is valid.

AE116	connection with 2 angle brackets			
factor:	for $F_1$	for $F_{2/3}$	for $F_{4/5, \text{bolt 1}}$	for $F_{4/5, \text{bolt 2}}$
$k_{ax}$ square washer	0,65	-	$1,3 \times e/(b+7)$	-
$k_{lat}$ square washer	-	0,5 and $M=F_2 \times 12\text{mm}^*1$	-	1,00
$k_{ax}$ round washer	0,70	-	$1,39 \times e/(b+7)$	-
$k_{lat}$ round washer	-	0,5 and $M=F_2 \times 12\text{mm}^*1$	-	1,00

e and b are in [mm]

For each bolt (bolt group) it's needed to check:

 $R_{\text{bolt,d,lateral}} \geq k_{\text{lat}} \times F_{i,d}$  ;  $R_{\text{bolt,d,axial}} \geq k_{\text{ax}} \times F_{i,d}$  ; and also the combination

Square washer = US40/40/10G or US40/50/10G

Round washer = standard washer of the anchor bolt. For anchor Ø12 the washer diameter is Ø24

Table D17-4 Modified characteristic capacity timber beam to rigid support – 1 Angle Bracket

1 Angle Bracket AE116 per connection			Modified characteristic capacity				
Nailing pattern	Number of fasteners		Load duration	$R_{1,k} \times k_{mod}$ (Purlin may rotate)		$R_{2/3,k} \times k_{mod}$	
	Flange A	Flange B		CNA Connector nail			
				4.0x40	4.0x60	4.0x40	4.0x60
Nailing pattern 7	12	2 Bolts Ø12	P	42/(f+9)	42/(f+9)	7,8	8,3
			L	42/(f+9)	42/(f+9)	9	9,7
			M	42/(f+9)	42/(f+9)	10,3	11,1
			S	42/(f+9)	42/(f+9)	11,6	12,5
			I	42/(f+9)	42/(f+9)	14,2	15,3
Nailing Pattern 8	14	2 Bolts Ø12	P	-	-	8,2	8,5
			L	-	-	9,6	10
			M	-	-	11	11,4
			S	-	-	12,4	12,8
			I	-	-	15,1	15,7
Nailing Pattern 9	12	2 Bolts Ø12	P	42/(f+9)	42/(f+9)	7,4	8,2
			L	42/(f+9)	42/(f+9)	8,6	9,5
			M	42/(f+9)	42/(f+9)	9,8	10,9
			S	42/(f+9)	42/(f+9)	11,1	12,3
			I	42/(f+9)	42/(f+9)	13,5	15

f is in [mm]

AE116	connection with 1 angle brackets	
factor:	for $F_1$	for $F_{2/3}$
$k_{ax}$ square	$(f+44)/23$	0,18
$k_{lat}$ square	-	1,00
$k_{ax}$ round	$(f+44)/23$	0,18
$k_{lat}$ round	-	1,00

f is in [mm]

For each bolt (bolt group) it's needed to check:

 $R_{bolt,d,lateral} \geq k_{lat} \times F_{i,d}$  ;  $R_{bolt,d,axial} \geq k_{ax} \times F_{i,d}$  ; and also the combination

Square washer = US40/40/10G or US40/50/10G

Round washer = standard washer of the anchor bolt. For anchor Ø12 the washer diameter is Ø24

Table D17-5 Modified characteristic capacity timber beam to rafter connection - 2 Angle Brackets

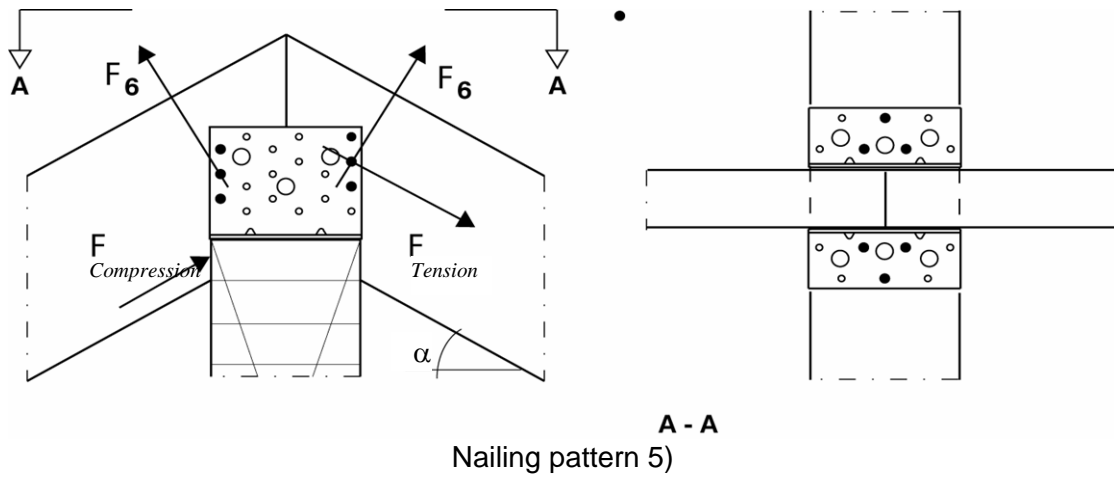

2 Angle Brackets per connection	Modified characteristic capacity per connection									
	R <sub>6,singlesided</sub> on one rafter				Symmetrical R <sub>6,symmetrical</sub> on each of two rafters		Height h <sub>contact</sub> of contact area between rafter and ridge beam			
Load duration: I	b <sub>ridgebeam</sub> [mm]									
	80	90	100	120	>80		80	90	100	120
Roof pitch α [°]	R <sub>6,singlesided</sub> [kN]				R <sub>6,symmetrical</sub> [kN]		h <sub>contact</sub> [mm]			
0	4,5	4,6	4,6	4,6	2,7		0	0	0	0
5	4,6	4,6	4,6	4,7	2,7		3	4	4	5
10	4,6	4,6	4,7	4,7	2,7		7	8	9	11
15	4,7	4,7	4,7	4,7	2,8		11	12	13	16
20	4,7	4,7	4,7	4,7	2,9		15	16	18	22
25	4,7	4,8	4,8	4,8	3,0		19	21	23	28
30	4,8	4,8	4,8	4,8	3,1		23	26	29	35
35	4,8	4,8	4,8	4,8	3,3		28	32	35	42
40	4,9	4,9	4,9	4,9	3,5		34	38	42	50
45	4,9	4,9	4,9	4,9	3,8		40	45	50	60

Same roof pitch at both side of the roof

Connector nail according to ETA-04/0013 4,0x40 in rafter and 4,0x60 in ridge beam

The capacities in the table are for Instant load duration, the capacities for other load durations are found by multiplication by the factor c

Factor c for other load durations	P	L	M	S
	0,55	0,64	0,73	0,82

Table D17-6 AE116 – Slip modulus  $K_{ser}$ 

AE116				$K_{ser}$ [kN/mm]			
	Nail pattern	Fastener		For F1		For F2	
		Flange A	Flange B	CNA4.0x40	CNA4.0x60	CNA4.0x40	CNA4.0x60
2 x AE116 per Connection	7	2 x 12	2 x 2 x M12	10,4	11,5	9,5	10,0
	1	2 x 12	2 x 7	2,1	3,4	3,2	4,5
	3	2 x 8	2 x 7	2,1	3,4	2,7	3,7
1 x AE116 per Connection	7	12	2 x M12	5,2	5,8	4,8	5,0
	1	12	7	1,1	1,7	1,6	2,3
	3	8	7	1,1	1,7	1,4	1,9

**Combined symmetrical and single sided forces**

For a combination of symmetrical and single sided load, the load carrying capacity is found from the following criteria:

$$\frac{F_{6,symmetrical}}{R_{6,symmetrical,d}} + \frac{F_{6,singlesided}}{R_{6,singlesided,d}} \leq 1$$

**Combined symmetrical and single sided and tension force**

For a combination of symmetrical, single sided force and tension in a rafter, the load carrying capacity is found from the following criteria:

$$\frac{F_{6,symmetrical}}{R_{6,symmetrical,d}} + \frac{F_{6,singlesided}}{R_{6,singlesided,d}} + \frac{F_{tension} \cdot \cos(\alpha)}{R_{tension,d}} \leq 1$$

Where:  $R_{tension} = 13 \cdot c$  kN, where c is the load duration factor.

**Compression**

The compressive force in the rafter is decomposed into a vertical force,  $F_{compression} \cdot \sin(\alpha)$  and a horizontal force  $F_{compression} \cdot \cos(\alpha)$ .

The compressive force on the side of the ridge beam consist of contributions from both the rafter loaded in tension,  $F_{tension} \cdot \cos(\alpha)$  and from the rafter loaded in compression  $F_{compression} \cdot \cos(\alpha)$ . The ridge beam must be checked for the compressive force acting perpendicular to the grain.

The maximum force considering the capacity perpendicular to the grain is found from the following expression:

$$R_{c,90,k} = f_{c,90,k} \cdot \left( 2,38 - \frac{b_{rafter}}{250} \right) \cdot \left( 1 + \frac{b_{ridgebeam}}{6 \cdot b_{rafter}} \right) \cdot b_{rafter} \cdot h_{contact}$$

Where:

$f_{c,90,k}$  = characteristic compression strength perpendicular to the grain of ridge beam

$b_{rafter}$  = width of rafter [mm]

$b_{ridgebeam}$  = width of ridge beam [mm]

$h_{contact}$  = height of contact area between rafter and ridge beam, see table above

The capacity of the connection is verified from the following criteria:

$$(F_{compression} + F_{tension}) \cdot \cos(\alpha) \leq R_{c,90,k}$$

## Annex D18 – AG40312, AG40412, AG40314 & AG40414

### Product Name:

Product Name	Material reference acc. to clause II-1	Alternative product names
AG40312	Steel ref. 1	France: EB/7312
AG40412	Steel ref. 1	-
AG40314	Steel ref. 1	-
AG40414	Steel ref. 1	-
AG40312S	Steel ref. 2	-
AG40412S	Steel ref. 2	-
AG40314S	Steel ref. 2	-
AG40414S	Steel ref. 2	-
AG40312S2	Steel ref. 3	-
AG40412S2	Steel ref. 3	-
AG40314S2	Steel ref. 3	-
AG40414S2	Steel ref. 3	-

### Connector Size Range:

Model no.	Dimensions [mm]				Holes flange A			Holes flange B		
	A	B	C	Thickness	Ø5	Ø8,5	Ø11	Ø5	Ø8,5	Ø11
AG40312	119	91	40	3,0	10	1	2	6	1	1
AG40412	120	92	40	4,0	10	1	2	6	1	1
AG40314	141	91	40	3,0	12	1	2	6	1	1
AG40414	142	92	40	4,0	12	1	2	6	1	1

### Drawing:

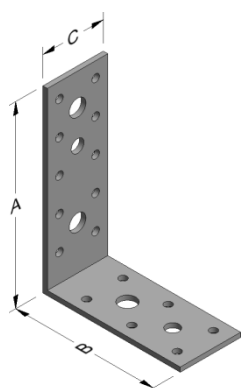

AG40312, AG40412

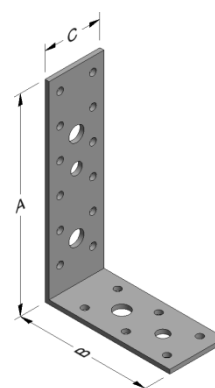

AG40314, AG40414



**Nailing pattern:**

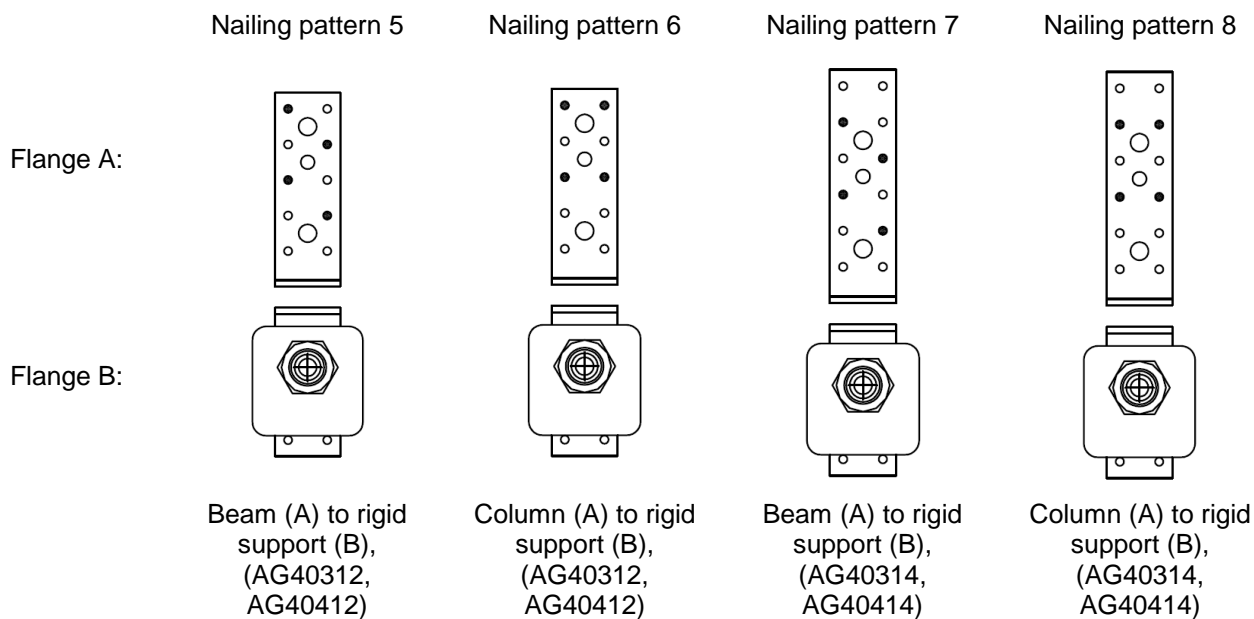
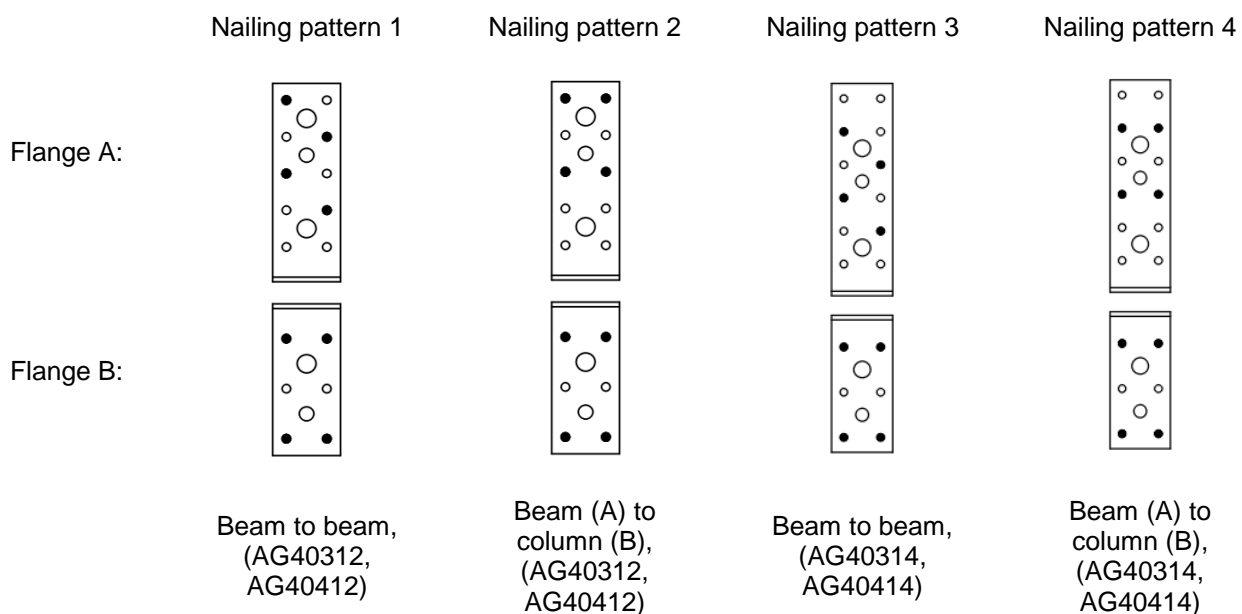

**Table D18-1 Modified characteristic capacity timber beam to timber beam or timber beam to timber column – 2 Angle Brackets**

2 Angle Brackets AG40312 or AG40314 per connection			Modified characteristic capacity per connection (kN)						
Nailing pattern	Number of fasteners		Load duration	$R_{1,k} \times k_{mod}$		$R_{2/3,k} \times k_{mod}$		$R_{4/5,k} \times k_{mod}$	
	Flange A	Flange B		CNA Connector nail					
				4,0x40	4,0x60	4,0x40	4,0x60	4,0x40	4,0x60
Nailing patterns 1, 2, 3, 4	4	4	S	2,7	3,9	3,0	4,5	$e \leq 0,29b+15$ 4,6 $e > 0,29b+15$ <u>1.32b+56</u> e-3,0	$e \leq 0,43b+18$ 4,6 $e > 0,43b+18$ <u>1.96b+70</u> e-3,0
			M	2,4	3,6	2,6	4,0	$e \leq 0,27b+15$ 4,3 $e > 0,27b+15$ <u>1.18b+52</u> e-3,0	$e \leq 0,42b+18$ 4,3 $e > 0,42b+18$ <u>1.80b+66</u> e-3,0

b and e are in mm

Factors for other load durations	$R_{1,k}$		$R_{2/3,k}$		$R_{4/5,k}$	
	CNA Connector nail					
	4,0x40	4,0x60	4,0x40	4,0x60	4,0x40	4,0x60
I multiply S by	1,19	1,16	1,22	1,22	1,11	1,11
L multiply M by	0,88	0,91	0,88	0,88	0,88	0,92
P multiply M by	0,75	0,81	0,75	0,75	0,78	0,83

**Table D18-2 Modified characteristic capacity timber beam to timber beam or timber beam to timber column – 1 Angle Bracket**

1 Angle Bracket AG40312 or AG40314 per connection			Modified characteristic capacity per connection (kN)				
Nailing pattern	Number of fasteners		Load duration	$R_{1,k} \times k_{mod}$ Purlin may rotate		$R_{2/3,k} \times k_{mod}$	
	Flange A	Flange B		CNA Connector nail			
				4,0x40	4,0x60	4,0x40	4,0x60
Nailing patterns 1, 2, 3, 4	4	4	P	min: 55 f + 81 20 f + 19	20 f + 19	1,0	1,4
			L	20 f + 19	20 f + 19	1,2	1,7
			M	20 f + 19	20 f + 19	1,3	1,9
			S	20 f + 19	20 f + 19	1,5	2,1
			I	20 f + 19	20 f + 19	1,8	2,6

f is in mm

**Table D18-3 Modified characteristic capacity timber beam to timber beam or timber beam to timber column – 2 Angle Brackets**

2 Angle Brackets AG40412 or AG40414 per connection			Modified characteristic capacity per connection (kN)						
Nailing pattern	Number of fasteners		Load duration	$R_{1,k} \times k_{mod}$		$R_{2/3,k} \times k_{mod}$		$R_{4/5,k} \times k_{mod}$	
	Flange A	Flange B		CNA Connector nail					
				4,0x40	4,0x60	4,0x40	4,0x60	4,0x40	4,0x60
Nailing patterns 1, 2, 3, 4	4	4	S	2,7	4,4	2,9	4,0	$e \leq 0,22b+16$ 6,1	$e \leq 0,36b+19$ 6,1
			M	2,4	3,9	2,6	3,5	$e > 0,22b+16$ $\frac{1,32b+76}{e-4,0}$	$e > 0,36b+19$ $\frac{2,21b+96}{e-4,0}$
								$e \leq 0,20b+16$ 5,75	$e \leq 0,34b+19$ 5,75
								$e > 0,20b+16$ $\frac{1,18b+73}{e-4,0}$	$e > 0,34b+19$ $\frac{1,96b+90}{e-4,0}$

f are in mm

Factors for other load durations	$R_{1,k}$		$R_{2/3,k}$		$R_{4/5,k}$	
	CNA Connector nail					
	4,0x40	4,0x60	4,0x40	4,0x60	4,0x40	4,0x60
I multiply S by	1,22	1,22	1,22	1,22	1,10	1,10
L multiply M by	0,88	0,88	0,88	0,88	0,85	0,89
P multiply M by	0,75	0,75	0,75	0,75	0,65	0,78

*Table D18-4 Modified characteristic capacity timber beam to timber beam or timber beam to timber column – 1 Angle Bracket*

1 Angle Bracket AG40412 or AG40414 per connection			Modified characteristic capacity per connection (kN)				
Nailing pattern	Number of fasteners		Load duration	$R_{1,k} \times k_{mod}$ Purlin may rotate		$R_{2/3,k} \times k_{mod}$	
	Flange A	Flange B		CNA Connector nail			
				4,0x40	4,0x60	4,0x40	4,0x60
Nailing patterns 1, 2, 3, 4	4	4	P	min: <u>55</u> f + 82 <u>35</u> f + 20	min: <u>91</u> f + 82 <u>35,0</u> f + 20	1,0	1,3
			L	min: <u>64</u> f + 82 <u>35</u> f + 20	min: <u>106</u> f + 82 <u>35,0</u> f + 20	1,1	1,6
			M	min: <u>73</u> f + 82 <u>35</u> f + 20	min: <u>122</u> f + 82 <u>35</u> f + 20	1,3	1,8
			S	min: <u>82</u> f + 82 <u>35</u> f + 20	<u>35</u> f + 20	1,5	2,0
			I	min: <u>100,0</u> f + 82 <u>35,0</u> f + 20	<u>35</u> f + 20	1,8	2,4

f is in mm.

Table D18-5 Modified characteristic capacity timber beam or timber column to rigid support – 2 Angle Brackets

2 Angle Brackets AG40412 or AG40414 per connection			Modified characteristic capacity per connection (kN)						
Nailing pattern	Number of fasteners		Load duration	$R_{1,k} \times k_{mod}$		$R_{2/3,k} \times k_{mod}$		$R_{4/5,k} \times k_{mod}$	
	Flange A	Flange B		CNA Connector nail					
				4,0x40	4,0x60	4,0x40	4,0x60	4,0x40	4,0x60
Nailing patterns 5, 6, 7, 8	4	1 Bolt	S	8,1	8,1	1,0	1,0	$\frac{4,1b+61}{e-4,0}$ max: 6,1	$\frac{4,1b+61}{e-4,0}$ max: 6,1
			M	8,1	8,1	0,8	1,0	$\frac{4,1b+61}{e-4,0}$ max: 5,7	$\frac{4,1b+61}{e-4,0}$ max: 5,7

b and e are in mm

Factors for other load durations	$R_{1,k}$		$R_{2/3,k}$		$R_{4/5,k}$	
	4,0x40	4,0x60	4,0x40	4,0x60	4,0x40	4,0x60
I multiply S by	1,00	1,00	1,00	1,00	1,00	1,00
L multiply M by	0,91	1,00	1,00	1,00	0,86	0,95
P multiply M by	0,78	1,00	0,75	1,00	0,67	0,88

2 Angle Brackets AG per connection				
factor for:	$F_1$	$F_{2/3}$	$F_{4/5, \text{bolt 1}}$	$F_{4/5, \text{bolt 2}}$
$k_{ax}$	0,93	1,69	$1,85 \times e/B$	-
$k_{lat}$	-	0,50	-	1,00

For each bolt it's needed to check:  $R_{bolt, d, lateral} \geq k_{lat} \times F_{i, d}$ ;  $R_{bolt, d, axial} \geq k_{ax} \times F_{i, d}$ ; and also the combination.

Table D18-6 Modified characteristic capacity timber beam or timber column to rigid support – 1 Angle Bracket

1 Angle Brackets AG40412 or AG40414 per connection			Modified characteristic capacity per connection (kN)				
Nailing pattern	Number of fasteners		Load duration	R <sub>1,k</sub> x k <sub>mod</sub> Purlin may rotate		R <sub>2/3,k</sub> x k <sub>mod</sub>	
	Flange A	Flange B		CNA Connector nail			
				4,0x40	4,0x60	4,0x40	4,0x60
Nailing patterns 5, 6, 7, 8	4	1 Bolt	S	min: <u>47</u> f+7 <u>148</u> f+67	min: <u>47</u> f+7 <u>148</u> f+67	0,5	0,5
			M	min: <u>47</u> f+7 <u>148</u> f+67	min: <u>47</u> f+7 <u>148</u> f+67	0,4	0,5

f is in mm

Factors for other load durations	R <sub>1,k</sub> Purlin may rotate		R <sub>2/3,k</sub>	
	CNA Connector nail			
	4,0x40	4,0x60	4,0x40	4,0x60
I multiply S by	1,00	1,00	1,00	1,00
L multiply M by	1,00	1,00	1,00	1,00
P multiply M by	1,00	1,00	0,75	1,00

1 Angle Bracket AG per connection				
factor for:	F <sub>1</sub>	F <sub>2/3</sub>	F <sub>4</sub>	F <sub>5</sub>
k <sub>ax</sub>	1,85	3,38	-	-
k <sub>lat</sub>	-	1,00	-	-

For each bolt it's needed to check:  $R_{\text{bolt},d,\text{lateral}} \geq k_{\text{lat}} \times F_{i,d}$ ;  $R_{\text{bolt},d,\text{axial}} \geq k_{\text{ax}} \times F_{i,d}$ ; and also the combination.

## Annex D19 – AH9035

### Product Name:

Product Name	Material reference acc. to clause II-1	Alternative product names
AH9035	Steel ref. 1	-
AH9035S	Steel ref. 2	-
AH9035S2	Steel ref. 3	-

### Connector Size Range:

Model no.	Dimensions [mm]				Holes flange A		Holes flange B	
	A	B	C	Thickness	Ø5	Ø9	Ø5	Ø9
AH9035	90	35	40	2,5	6	1	4	1

### Drawing:

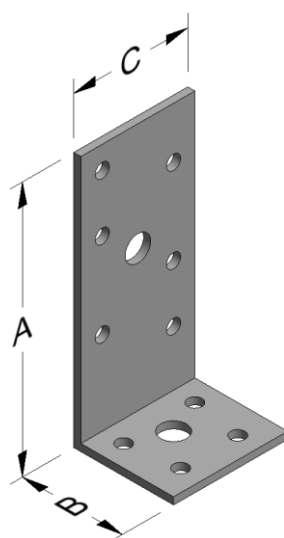

### Nailing pattern:

Nailing pattern 1

Flange A:

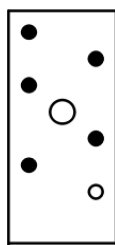

Flange B:

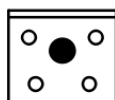

Beam (A) to rigid support (B)



*Table D19-1 Modified characteristic capacity timber beam to rigid support – 1 Angle Bracket*

1 Angle Bracket AH9035 per connection				Modified characteristic capacity per connection (kN)	
Nailing pattern	Number of fasteners		Load duration	$R_{1,k} \times k_{mod} = \min \text{ of:}$	
	Flange A	Flange B		CNA Connector nail	
				4,0x40	4,0x60
Nailing pattern 1	5	1 Bolt	S	$(1,43+(n-2) \cdot 1,64) \cdot c$	$(2,25+(n-2) \cdot 2,13) \cdot c$
				1,9	1,9
				$(3,09+(n-2) \cdot 1,64) \cdot c$	$(4,10+(n-2) \cdot 2,13) \cdot c$
				4,0	4,0
				0,32 · F <sub>b,k</sub> + 0,91	
				0,19 · F <sub>anchor,concrete</sub> + 0,54	

■ When the purlin has a wane on the side towards the Angle Bracket with an extent from the bottom up to the lower nail the value in the grey square is valid.

The capacities in the table are for short load duration, the capacities for other load durations are found by multiplication by the factor c

Factor c for other load durations	P	L	M	S	I
	0,67	0,78	0,89	1,00	1,22

The bolt shall have a capacity to sustain an axial force of  $F_{1,d} \times 3,1$

## Annex D20 – AJ60416

### Product Name:

Product Name	Material reference acc. to clause II-1	Alternative product names
AJ60416	Steel ref. 1	-
AJ60416S	Steel ref. 2	-
AJ60416S2	Steel ref. 3	-

### Connector Size Range:

Model no.	Dimensions [mm]				Holes flange A	Holes flange B
	A	B	C	Thickness	Ø5	Ø5
AJ60416	164	84	60	4,0	8	7

### Drawing:

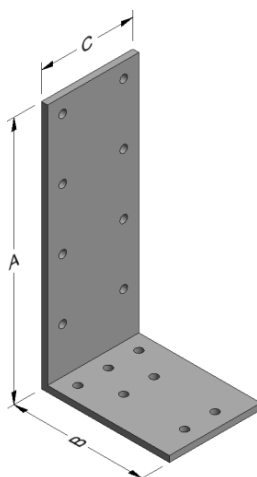

### Nailing pattern:

#### Nailing pattern 1

Flange A:

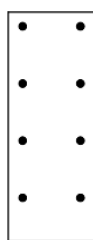

Flange B:

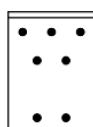

Beam to Beam  
Full nailing

Table D20-1 Modified characteristic capacity timber beam to timber beam – 2 Angle Brackets

2 Angle Brackets AJ60416 per connection				Modified characteristic capacity per connection (kN)		
Nailing pattern	Number of fasteners		Load duration	$R_{1,k} \times k_{mod}$	$R_{2/3,k} \times k_{mod}$	$R_{4/5,k} \times k_{mod}$
	Flange A	Flange B		CNA Connector nail		
Nailing pattern1	8 x CNA4,0x40	7 x CNA4,0x60	S	10,2	7,0	min: 8,9  $\frac{5,11b+107}{e-4,0}$
			M	9,3	6,2	min: 7,1  $\frac{4,65b+103}{e-4,0}$

b and e are in mm

Factors for other load durations	$R_{1,k}$	$R_{2,k} = R_{3,k}$	$R_{4,k} = R_{5,k}$
		CNA Connector nail Vertical flange: 8 CNA4,0x40 - Horizontal flange: 7 CNA4,0x60	
I multiply S by	1,18	1,22	1,14
L multiply M by	0,90	0,88	0,85
P multiply M by	0,80	0,75	0,79

Table D20-2 Modified characteristic capacity timber beam to timber beam – 1 angle bracket

1 Angle Bracket AJ60416 per connection				Modified characteristic capacity per connection (kN)			
Nailing pattern	Number of fasteners		Load duration	$R_{1,k} \times k_{mod}$ Purlin may rotate	$R_{2/3,k} \times k_{mod}$	$R_{4,k} \times k_{mod}$	$R_{5,k} \times k_{mod}$
	Flange A	Flange B		CNA Connector nail			
Nailing pattern1	8 x CNA4,0x40	7 x CNA4,0x60	S	min: 205 f+74 $\frac{55}{f}$ 53,1 f+12	3,5	min: 6,0  53,1 e-2,0	min: 2,8  109 114-e $\frac{4,6(b+2,0)}{e}$
			M	min: 182,0 f+74 50,0 f 53,1 f+12	3,1	min: 5,6  53,1 e-2,0	min: 2,6  96 114-e $\frac{4,2(b+2,0)}{e}$

f, e and b are in mm

Factors for other load durations	$R_{1,k}$	$R_{2/3,k}$	$R_{4,k}$	$R_{5,k}$
		CNA Connector nail Vertical flange: 8 CNA4,0x40 - Horizontal flange: 7 CNA4,0x60		
I multiply S by	1,00	1,22	1,00	1,14
L multiply M by	0,88	0,88	0,95	0,88
P multiply M by	0,75	0,75	0,88	0,75

## Annex D21 – AJ80416

### Product Name:

Product Name	Material reference acc. to clause II-1	Alternative product names
AJ80416	Steel ref. 1	-
AJ80416S	Steel ref. 2	-
AJ80416S2	Steel ref. 3	-

### Connector Size Range:

Model no.	Dimensions [mm]				Holes flange A	Holes flange B
	A	B	C	Thickness	Ø5	Ø5
AJ60416	164	84	80	4,0	8	7

### Drawing:

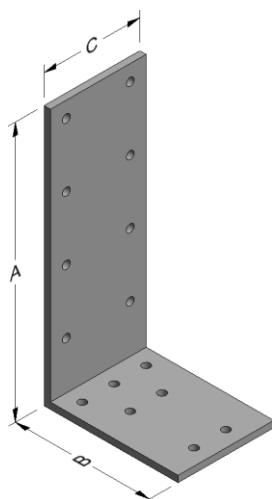

### Nailing pattern:

#### Nailing pattern 1

Flange A:

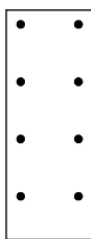

Flange B:

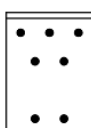

Beam to Beam  
Full nailing

**Table D21-1 Modified characteristic capacity timber beam to timber beam – 2 Angle Brackets**

2 Angle Brackets AJ80416 per connection				Modified characteristic capacity per connection (kN)		
Nailing pattern	Number of fasteners		Load duration	$R_{1,k} \times k_{mod}$	$R_{2/3,k} \times k_{mod}$	$R_{4/5,k} \times k_{mod}$
	Flange A	Flange B		CNA Connector nail		
Nailing pattern1	11 x CNA4,0x40	9 x CNA4,0x60	S	14,0	9,0	min: 12,4  $\frac{7,02b+144}{e-4,0}$
			M	12,8	8,0	min: 11,7  $\frac{6,39b+139}{e-4,0}$

b and e are in mm

Factors for other load durations	$R_{1,k}$	$R_{2/3,k}$	$R_{4/5,k}$
	CNA Connector nail		
I multiply S by	1,18	1,22	1,11
L multiply M by	0,90	0,88	0,86
P multiply M by	0,80	0,75	0,65

**Table D21-2 Modified characteristic capacity timber beam to timber beam – 1 Angle Bracket**

1 Angle Bracket AJ80416 per connection				Modified characteristic capacity per connection (kN)			
Nailing pattern	Number of fasteners		Load duration	$R_{1,k} \times k_{mod}$	$R_{2/3,k} \times k_{mod}$	$R_{4,k} \times k_{mod}$	$R_{5,k} \times k_{mod}$
	Flange A	Flange B		CNA Connector nail			
Nailing pattern1	11 x CNA4,0x40	9 x CNA4,0x60	S	min: $\frac{274}{f+74}$ 83 f $\frac{70,8}{f+12}$	4,5	min: 8,0  $\frac{70,8}{e-2,0}$	min: 3,7  $\frac{163}{121-e}$ $\frac{6,3(b+2,0)}{e}$
			M	min: $\frac{243}{f+74}$ 74 f $\frac{70,8}{f+12}$	4,0	min: 7,5  $\frac{70,8}{e-2,0}$	min: 3,5  $\frac{145}{121-e}$ $\frac{5,7(b+2,0)}{e}$

f, e and b are in mm

Factors for other load durations	$R_{1,k}$	$R_{2/3,k}$	$R_{4,k}$	$R_{5,k}$
	CNA Connector nail			
I multiply S by	1,00	1,22	1,00	1,14
L multiply M by	0,88	0,88	0,93	0,88
P multiply M by	0,75	0,75	0,87	0,75

## Annex D22 – AJ99416

### Product Name:

Product Name	Material reference acc. to clause II-1	Alternative product names
AJ99416	Steel ref. 1	-
AJ99416S	Steel ref. 2	-
AJ99416S2	Steel ref. 3	-

### Connector Size Range:

Model no.	Dimensions [mm]				Holes flange A	Holes flange B
	A	B	C	Thickness	Ø5	Ø5
AJ99416	164	84	100	4,0	12	11

### Drawing:

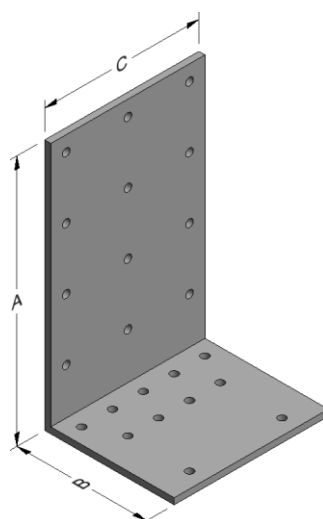

### Nailing pattern:

Nailing pattern 1

Flange A:

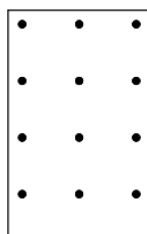

Flange B:

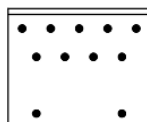

Beam to Beam  
Full nailing

**Table D22-1 Modified characteristic capacity timber beam to timber beam – 2 Angle Brackets**

2 Angle Brackets AJ99416 per connection				Characteristic capacity per connection (kN)		
Nailing	Number of fasteners		Load duration	$R_{1,k} \times k_{mod}$	$R_{2/3,k} \times k_{mod}$	$R_{4/5,k} \times k_{mod}$
	Flange A	Flange B		CNA Connector nail		
Nailing pattern1	12 x CNA4,0x40	11 x CNA4,0x60	S	17,9	11,7	min: 13,1 $\frac{8,93b+181}{e-4,0}$
			M	15,9	10,4	min: 10,9 $\frac{7,93b+174}{e-4,0}$

b and e are in mm

Factors for other load durations	$R_{1,k}$	$R_{2,k} = R_{3,k}$	$R_{4,k} = R_{5,k}$
	CNA Connector nail		
I multiply S by	1,18	1,22	1,14
L multiply M by	0,88	0,88	0,88
P multiply M by	0,75	0,75	0,77

**Table D22-2 Modified characteristic capacity timber beam to timber beam – 1 Angle Bracket**

1 Angle Bracket AJ99416 per connection				Modified characteristic capacity per connection (kN)			
Nailing pattern1	Number of fasteners		Load duration	$R_{1,k} \times k_{mod}$	$R_{2/3,k} \times k_{mod}$	$R_{4,k} \times k_{mod}$	$R_{5,k} \times k_{mod}$
	Flange A	Flange B		CNA Connector nail			
Nailing pattern1	12 x CNA4,0x40	11 x CNA4,0x60	S	min: $\frac{342}{f+74}$ $\frac{89}{f+12}$ $\frac{83}{f}$	5,9	min: 10,0 $\frac{89}{e-2,0}$	min: 4,7 $\frac{163}{114-e}$ $\frac{8,0(b+2,0)}{e}$
			M	min: $\frac{304}{f+74}$ $\frac{89}{f+12}$ $\frac{74}{f}$	5,2	min: 9,4 $\frac{89}{e-2,0}$	min: 4,3 $\frac{145}{114-e}$ $\frac{7,1(b+2,0)}{e}$

f, e and b are in mm

Factors for other load durations	$R_{1,k}$	$R_{2/3,k}$	$R_{4,k}$	$R_{5,k}$
	CNA Connector nail			
I multiply S by	1,00	1,22	1,00	1,13
L multiply M by	0,88	0,88	0,94	0,88
P multiply M by	0,75	0,75	0,87	0,75

**Annex D23 – KNAG90, 130, 170 & 210****Product Name:**

Product Name	Material reference acc. to clause II-1	Alternative product names
KNAG90	Steel ref. 1	France: ECH90/19090
KNAG130	Steel ref. 1	France: ECH125/19130
KNAG170	Steel ref. 1	France: ECH160/19170
KNAG210	Steel ref. 1	France: ECH200/19210
KNAG90S	Steel ref. 2	-
KNAG130S	Steel ref. 2	-
KNAG170S	Steel ref. 2	-
KNAG210S	Steel ref. 2	-
KNAG90S2	Steel ref. 3	-
KNAG130S2	Steel ref. 3	-
KNAG170S2	Steel ref. 3	-
KNAG210S2	Steel ref. 3	-

**Connector Size Range:**

Model no.	Dimensions [mm]				Holes flange A	Holes flange B
	A	B	C (A/B)	Thickness	Ø5	Ø5
KNAG90	90	90	55/65	2,0	6	8
KNAG130	125	125	64/80	2,0	9	10
KNAG170	160	160	80/95	2,0	11	12
KNAG210	200	200	84/100	2,0	14	14

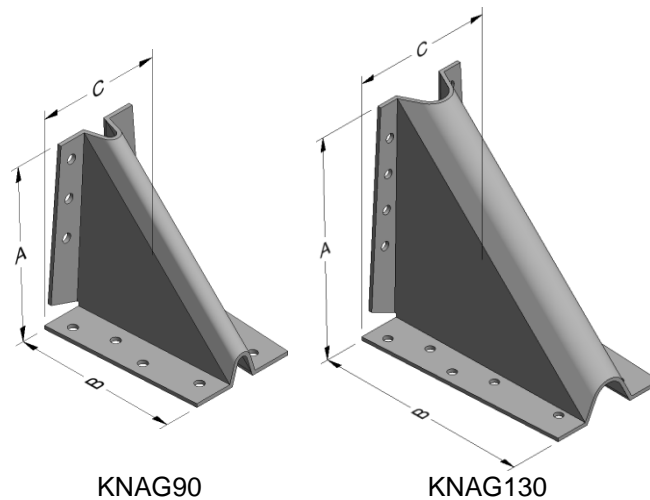
**Drawing:**



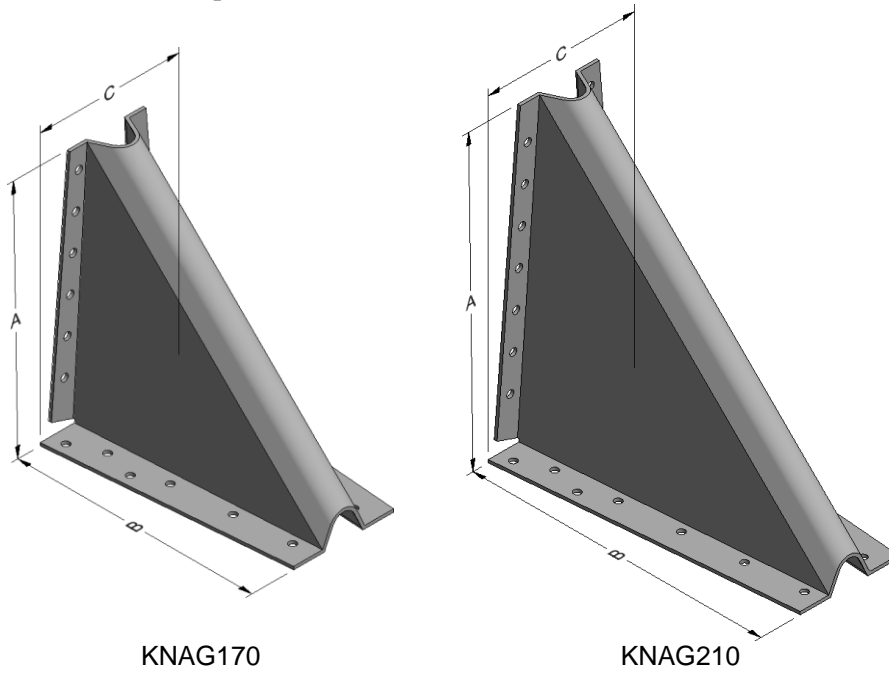

**Nailing pattern:**

Nailing pattern 1

Nailing pattern 2

Nailing pattern 3

Nailing pattern 4

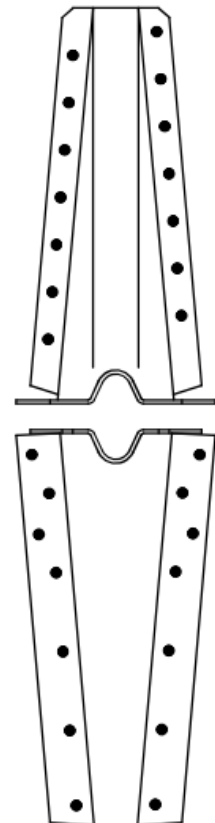
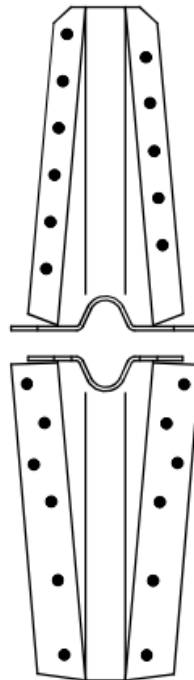
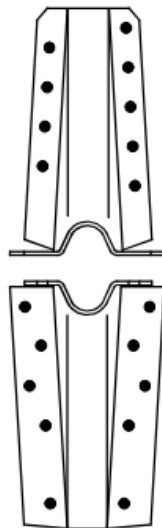
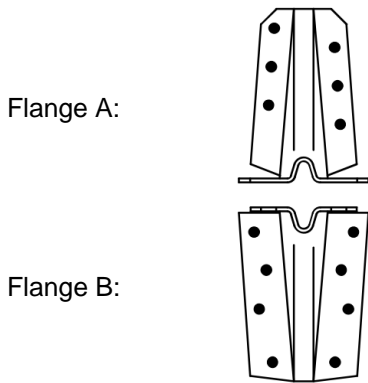

KNAG90  
Beam to Beam  
Full nailing

KNAG130  
Beam to Beam  
Full nailing

KNAG170  
Beam to Beam  
Full nailing

KNAG210  
Beam to Beam  
Full nailing

It is possible to make connections with a knight bracket and one or two joist anchors.

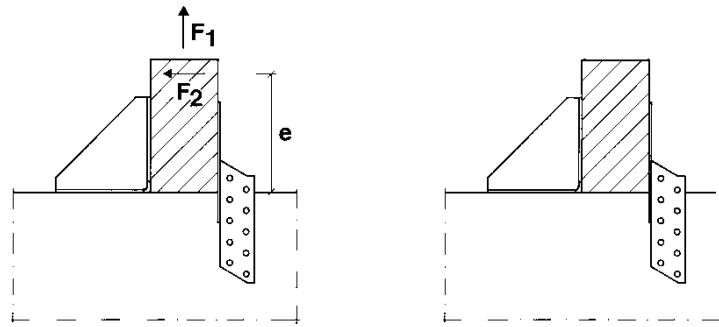

Typical connection with a knight bracket and a joist anchor

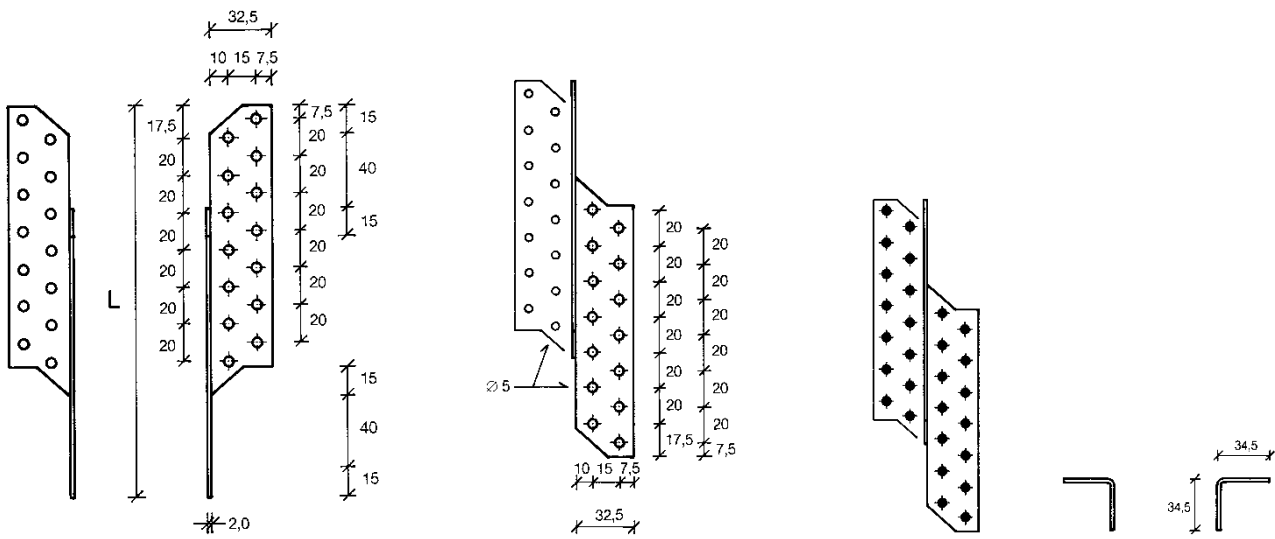

Dimensioned drawings of the joist anchors and nail patterns (full nailing)

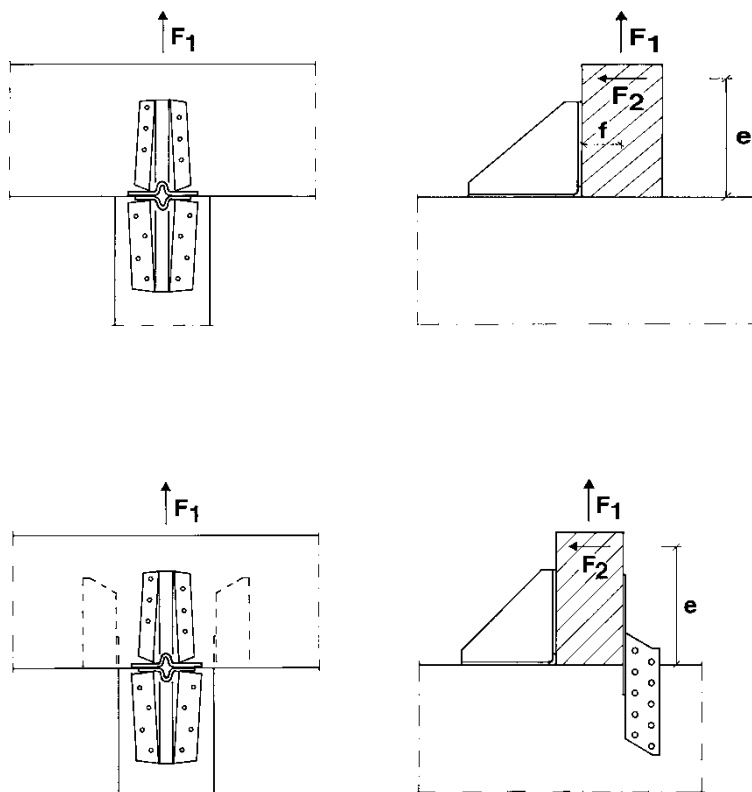

One knight bracket per connection

Acting forces

- $F_1$  Lifting force acting in the central axis of the angle bracket but in a distance  $f$  from the vertical flange of the knight bracket
- $F_2$  Lateral force acting in the beam direction perpendicular to the vertical flange elevated  $e$  above the beam directed towards the knight brackets vertical flange

One knight bracket and one or two joist anchors per connection

Acting forces

- $F_1$  Lifting force acting in the central axis of the knight bracket
- $F_2$  Lateral force acting in the beam direction perpendicular to the vertical flange elevated  $e$  above the beam directed towards the knight brackets vertical flange

Wane

Wane is not allowed under the knight bracket.

**Table D23-1 Modified characteristic capacity timber beam to timber beam – 1 Knight Bracket Load duration S**

1 Knight Bracket KNAG and 1 Joist Anchor per connection					Modified characteristic capacity per connection (kN)	
Bracket type	Nailing pattern	Number of fasteners		Load duration	$R_{1,k} \times k_{mod}$	$R_{2,k} \times k_{mod}$
		Flange A	Flange B		CNA Connector nail Beam: 4,0x60 - Joist: 4,0x40	
90	Nailing pattern 1	6 x CNA4,0x60	8 x CNA4,0x40	S	$f \leq 36$ : $\frac{201}{36+f}$	$e \leq 17$ : 14,9-0,314e $17 < e \leq 133$ : $\frac{164}{e}$ $133 < e$ : $\frac{77}{e-70}$
130	Nailing pattern 2	9 x CNA4,0x60	10 x CNA4,0x40		$f \leq 52$ : $\frac{475}{94+f}$	$e \leq 41$ : 19,1-0,232e $41 < e \leq 176$ : $\frac{392}{e}$ $176 < e$ : $\frac{181}{e-94}$
170	Nailing pattern 3	11 x CNA4,0x60	12 x CNA4,0x40		$f \leq 75$ : $\frac{777}{128+f}$	$e \leq 70$ : 23,4-0,198e $70 < e \leq 222$ : $\frac{672}{e}$ $222 < e$ : $\frac{297}{e-124}$
210	Nailing pattern 4	14 x CNA4,0x60	14 x CNA4,0x40		$f \leq 99$ : $\frac{1183}{169+f}$	$e \leq 89$ : 27,7-0,182e $89 < e \leq 289$ : $\frac{1026}{e}$ $289 < e$ : $\frac{486}{e-152}$

e and f are in mm

The capacities in the table are for short load duration, the capacities for other load durations are found by multiplication by the factor c

Factor c for other load durations	P	L	M	S	I
	0,67	0,78	0,89	1,00	1,19

Table D23-2 Modified characteristic capacity timber beam to timber beam – 1 Knight Bracket Load duration S

1 Knight Bracket KNAG and 1 or 2 joist anchors per connection			Modified characteristic capacity per connection (kN)						
Bracket type	Nailing	Load duration	Joist width mm	Min. Anchor force kN	No. of nails in anchor and example of anchortype	$R_{1,k} \times k_{mod}$		$R_{2,k} \times k_{mod}$	
						CNA Connector nail			
						4,0x40	4,0x60		
90	Full Nailing 6+8 Nailing pattern 1	S	50	7,5	8 nails 250	10,8	$e \leq 81$ : 11,9 $e > 81$ : <u>430</u> e-45		
			80	6,0	7 nails 250	9,3	$e \leq 96$ : 11,9 $e > 96$ : <u>612</u> e-45		
			100	5,5	7 nails 250	8,8	$e \leq 109$ : 11,9 $e > 109$ : <u>761</u> e-45		
130	Full Nailing 9+10 Nailing pattern 2		60	11,4	10 nails 290	16,4	$e \leq 106$ : 16,6 $e > 106$ : <u>703</u> e-64		
			100	9,0	9 nails 290	14,0	$e \leq 128$ : 16,6 $e > 128$ : <u>1056</u> e-64		
			140	7,9	9 nails 290	12,9	$e \leq 152$ : 16,6 $e > 152$ : <u>1469</u> e-64		
170	Full Nailing 11+12 Nailing pattern 3		60	19,9	2x10 nails 2x290	28,7	$e \leq 146$ : 21,4 $e > 146$ : <u>1406</u> e-80		
			100	15,6	2x8 nails 2x250	24,4	$e \leq 159$ : 21,4 $e > 159$ : <u>1683</u> e-80		
			140	13,7	2x7 nails 2x250	22,5	$e \leq 180$ : 21,4 $e > 180$ : <u>2129</u> e-80		
210	Full Nailing 14+14 Nailing pattern 4		80	25,2	2x11 nails 2x330	36,2	$e \leq 175$ : 26,3 $e > 175$ : <u>1930</u> e-102		
			120	20,6	2x9 nails 2x290	31,7	$e \leq 198$ : 26,3 $e > 198$ : <u>2536</u> e-102		
			160	18,3	2x9 nails 2x290	29,3	$e \leq 230$ : 26,3 $e > 230$ : <u>3365</u> e-102		

e are in mm

The capacities in the table are for short load duration, the capacities for other load durations are found by multiplication by the factor c

Factor c for other load durations	P	L	M	S	I
	0,67	0,78	0,89	1,00	1,19

**Annex D24 – ES10 & ES11****Product Name:**

Product Name	Material reference acc. to clause II-1	Alternative product names
ES10	Steel ref. 1	-
ES11	Steel ref. 1	-
ES10S	Steel ref. 2	France: ES10IX
ES11S	Steel ref. 2	-
ES10S2	Steel ref. 3	-
ES11S2	Steel ref. 3	-

**Connector Size Range:**

Model no.	Dimensions [mm]				Holes flange A	Holes flange B
	A	B	C	Thickness	Ø5	Ø5
ES10/40	62,5	62,5	40	2,5	5	5
ES10/60	62,5	62,5	60	2,5	8	8
ES10/80	62,5	62,5	80	2,5	10	10
ES10/100	62,5	62,5	100	2,5	10	10
ES10/120	62,5	62,5	120	2,5	12	12
ES10/140	62,5	62,5	140	2,5	14	14
ES10/160	62,5	62,5	160	2,5	16	16
ES11/40	82,5	82,5	40	2,5	7	7
ES11/60	82,5	82,5	60	2,5	11	11
ES11/80	82,5	82,5	80	2,5	14	14
ES11/100	82,5	82,5	100	2,5	15	15
ES11/120	82,5	82,5	120	2,5	18	18
ES11/140	82,5	82,5	140	2,5	21	21
ES11/160	82,5	82,5	160	2,5	24	24
ES11/180	82,5	82,5	180	2,5	27	27
ES11/200	82,5	82,5	200	2,5	30	30

**Drawing ES10:**

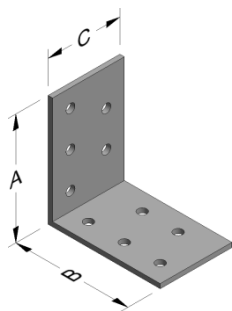

ES10/40

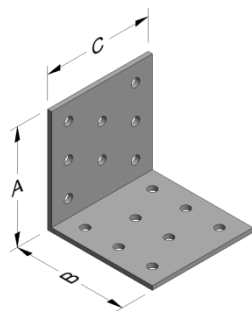

ES10/60

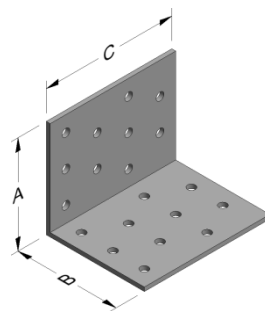

ES10/80

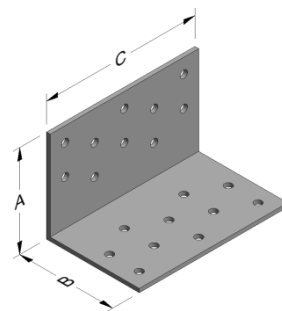

ES10/100

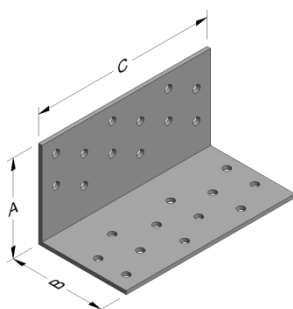

ES10/120

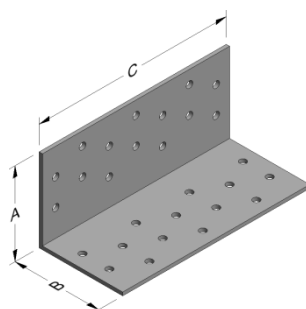

ES10/140

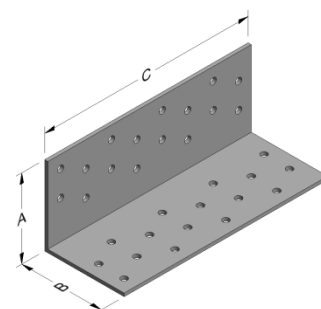

ES10/160

**Drawing ES11:**

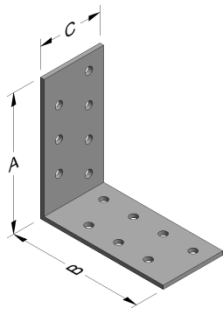

ES11/40

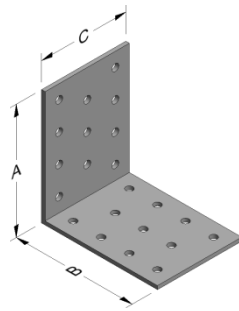

ES11/60

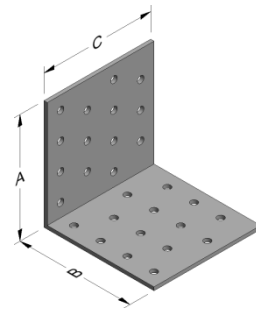

ES11/80

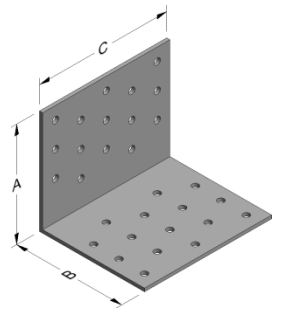

ES11/100

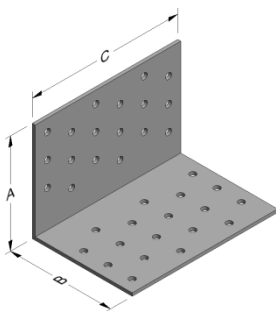

ES11/120

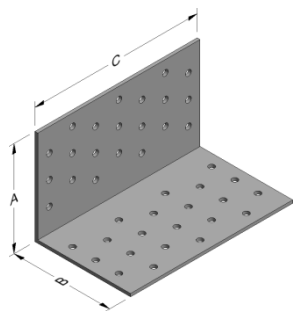

ES11/140

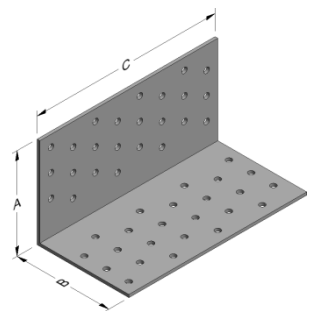

ES11/160

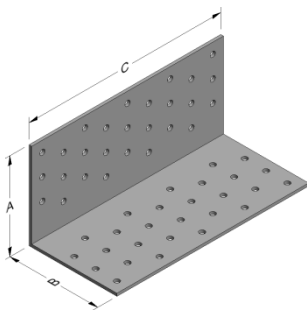

ES11/180

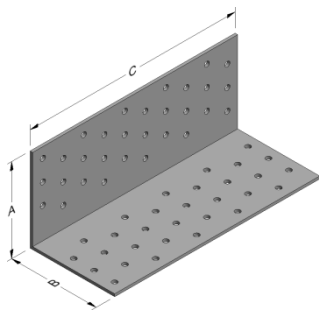

ES11/200



**Nailing pattern:**

Nailing pattern 1

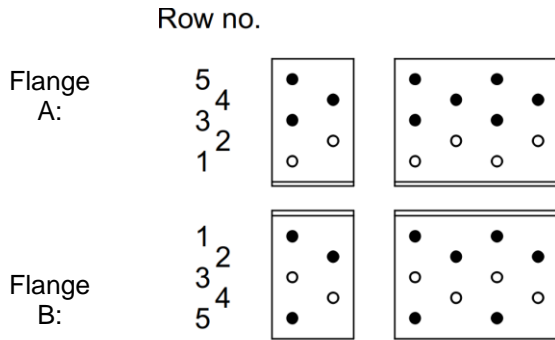

Nailing pattern 2

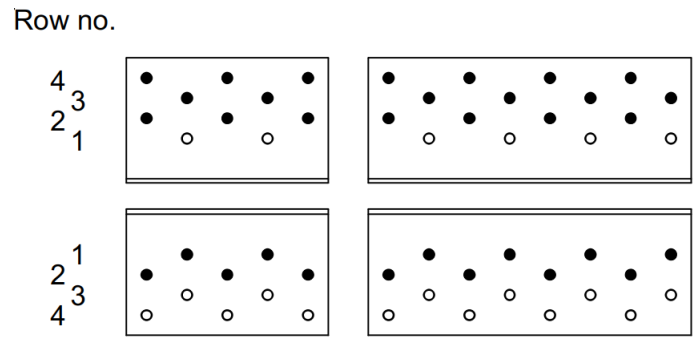

ES/10/40 to ES10/80

Beam to Beam  
 Flange A: Nailing in row no. 3, 4, 5  
 Flange B: Nailing in row no. 1, 2, 5

ES10/100 to ES10/160

Beam to Beam  
 Flange A: Nailing in row no. 2, 3, 4  
 Flange B: Nailing in row no. 1, 2

Nailing pattern 3

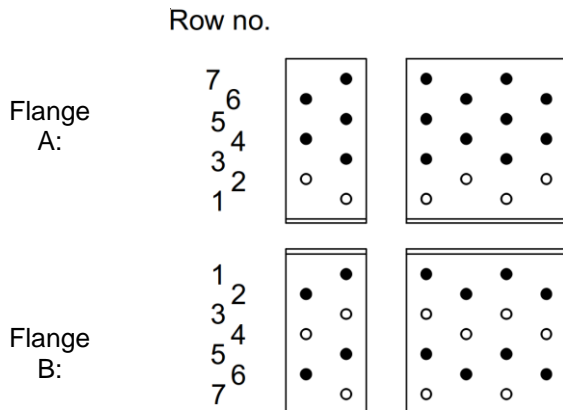

Nailing pattern 4

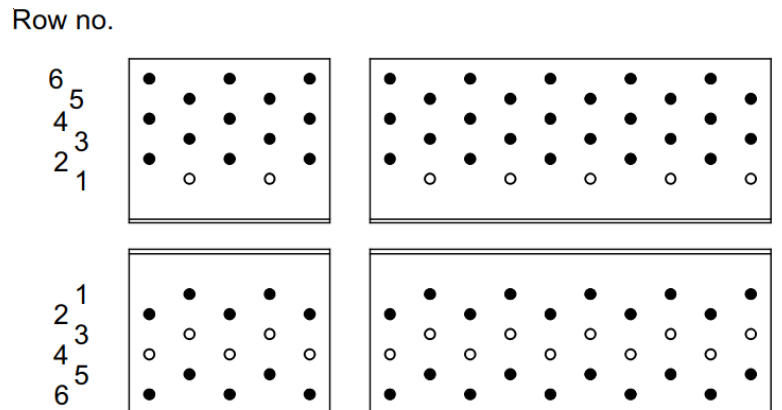

ES11/40 to ES11/80

Beam to Beam  
 Flange A: Nailing in row no. 3, 4, 5, 6, 7  
 Flange B: Nailing in row no. 1, 2, 5, 6

ES11/100 to ES11/200

Beam to Beam  
 Flange A: Nailing in row no. 2, 3, 4, 5, 6  
 Flange B: Nailing in row no. 1, 2, 5, 6

Table D24-1 ES10 Modified characteristic capacity timber beam to timber beam – 2 Angle Brackets

2 Angle Brackets ES10/40 per connection			Modified characteristic capacity per connection (kN)						
Nailing pattern	Number of fasteners		Load duration	$R_{1,k} \times k_{mod}$			$R_{2/3,k} \times k_{mod}$		
	Flange A	Flange B		CNA Connector nail					
				4,0 x 35	4,0 x 50	4,0 x 60	4,0 x 35	4,0 x 50	4,0 x 60
Nailing pattern 1	3	3	P	1,5	2,4	2,6	1,4	1,9	2,1
			L	1,7	2,6	2,7	1,7	2,2	2,4
			M	2,0	2,6	3,2	1,9	2,6	2,7
			S	2,2	2,8	3,7	2,2	2,9	3,1
			I	2,6	3,6	4,5	2,6	3,5	3,8

2 Angle Brackets ES10/60 per connection			Modified characteristic capacity per connection (kN)						
Nailing pattern	Number of fasteners		Load duration	$R_{1,k} \times k_{mod}$			$R_{2/3,k} \times k_{mod}$		
	Flange A	Flange B		CNA Connector nail					
				4,0 x 35	4,0 x 50	4,0 x 60	4,0 x 35	4,0 x 50	4,0 x 60
Nailing pattern 1	5	5	P	2,2	3,5	4,4	3,4	4,5	4,8
			L	2,6	4,1	4,4	3,9	5,2	5,6
			M	2,9	4,4	4,8	4,5	6,0	6,4
			S	3,3	4,4	5,6	5,1	6,7	7,2
			I	4,0	5,4	7,0	6,2	8,2	8,8

2 Angle Brackets ES10/80 per connection			Modified characteristic capacity per connection (kN)						
Nailing pattern	Number of fasteners		Load duration	$R_{1,k} \times k_{mod}$			$R_{2/3,k} \times k_{mod}$		
	Flange A	Flange B		CNA Connector nail					
				4,0 x 35	4,0 x 50	4,0 x 60	4,0 x 35	4,0 x 50	4,0 x 60
Nailing pattern 1	6	6	P	2,9	4,7	5,2	4,4	5,8	6,2
			L	3,4	5,2	5,4	5,1	6,8	7,3
			M	3,9	5,2	6,4	5,8	7,8	8,3
			S	4,4	5,6	7,4	6,6	8,7	9,3
			I	5,2	7,2	9,1	8,0	10,7	11,4

2 Angle Brackets ES10/100 per connection			Modified characteristic capacity per connection (kN)						
Nailing pattern	Number of fasteners		Load duration	$R_{1,k} \times k_{mod}$			$R_{2/3,k} \times k_{mod}$		
	Flange A	Flange B		CNA Connector nail					
				4,0 x 35	4,0 x 50	4,0 x 60	4,0 x 35	4,0 x 50	4,0 x 60
Nailing pattern 2	8	5	P	3,7	3,7	4,7	6,1	8,2	8,7
			L	3,7	4,3	6,0	7,2	9,5	10,2
			M	3,7	5,2	6,4	8,2	10,9	11,6
			S	3,7	6,2	6,4	9,2	12,2	13,1
			I	4,1	6,4	6,4	11,2	15,0	16,0

2 Angle Brackets ES10/120 per connection				Modified characteristic capacity per connection (kN)					
Nailing pattern	Number of fasteners		Load duration	$R_{1,k} \times k_{mod}$			$R_{2/3,k} \times k_{mod}$		
	Flange A	Flange B		CNA Connector nail					
				4,0 x 35	4,0 x 50	4,0 x 60	4,0 x 35	4,0 x 50	4,0 x 60
Nailing pattern 2	9	6	P	4,4	4,6	5,8	7,5	10,0	10,6
			L	4,6	5,2	7,3	8,7	11,6	12,4
			M	4,6	6,4	8,0	10,0	13,3	14,1
			S	4,6	7,6	8,0	11,2	14,9	15,9
			I	5,1	8,0	8,0	13,7	18,2	19,4

2 Angle Brackets ES10/140 per connection				Modified characteristic capacity per connection (kN)					
Nailing pattern	Number of fasteners		Load duration	$R_{1,k} \times k_{mod}$			$R_{2/3,k} \times k_{mod}$		
	Flange A	Flange B		CNA Connector nail					
				4,0 x 35	4,0 x 50	4,0 x 60	4,0 x 35	4,0 x 50	4,0 x 60
Nailing pattern 2	10	7	P	5,2	5,2	6,7	10,0	13,4	14,2
			L	5,2	6,0	8,4	11,7	15,6	16,6
			M	5,2	7,4	9,1	13,4	17,8	19,0
			S	5,2	8,7	9,1	15,1	20,0	21,4
			I	5,8	9,1	9,1	18,4	24,5	26,1

2 Angle Brackets ES10/160 per connection				Modified characteristic capacity per connection (kN)					
Nailing pattern	Number of fasteners		Load duration	$R_{1,k} \times k_{mod}$			$R_{2/3,k} \times k_{mod}$		
	Flange A	Flange B		CNA Connector nail					
				4,0 x 35	4,0 x 50	4,0 x 60	4,0 x 35	4,0 x 50	4,0 x 60
Nailing pattern 2	12	8	P	5,9	6,1	7,7	11,4	15,2	16,2
			L	6,1	7,0	9,7	13,3	17,8	18,9
			M	6,1	8,5	10,6	15,2	20,3	21,6
			S	6,1	10,1	10,6	17,2	22,8	24,3
			I	6,8	10,6	10,6	21,0	27,9	29,8

Table D24-2 ES11 Modified characteristic capacity timber beam to timber beam – 2 Angle Brackets

2 Angle Brackets ES11/40 per connection				Modified characteristic capacity per connection (kN)					
Nailing pattern	Number of fasteners		Load duration	$R_{1,k} \times k_{mod}$			$R_{2/3,k} \times k_{mod}$		
	Flange A	Flange B		CNA Connector nail					
				4,0 x 35	4,0 x 50	4,0 x 60	4,0 x 35	4,0 x 50	4,0 x 60
Nailing pattern 3	5	4	P	1,5	2,4	2,6	2,1	2,8	3,0
			L	1,7	2,6	2,7	2,5	3,3	3,5
			M	2,0	2,6	3,2	2,8	3,7	4,0
			S	2,2	2,8	3,7	3,1	4,2	4,5
			I	2,6	3,6	4,5	3,8	5,1	5,5

2 Angle Brackets ES11/60 per connection			Modified characteristic capacity per connection (kN)						
Nailing pattern	Number of fasteners		Load duration	$R_{1,k} \times k_{mod}$			$R_{2/3,k} \times k_{mod}$		
	Flange A	Flange B		CNA Connector nail					
				4,0 x 35	4,0 x 50	4,0 x 60	4,0 x 35	4,0 x 50	4,0 x 60
Nailing pattern 3	8	6	P	2,2	3,5	4,4	4,4	5,9	6,3
			L	2,6	4,1	4,4	5,2	6,9	7,3
			M	2,9	4,4	4,8	5,9	7,9	8,4
			S	3,3	4,4	5,6	6,7	8,9	9,4
			I	4,0	5,4	7,1	8,1	10,8	11,5

2 Angle Brackets ES11/80 per connection			Modified characteristic capacity per connection (kN)						
Nailing pattern	Number of fasteners		Load duration	$R_{1,k} \times k_{mod}$			$R_{2/3,k} \times k_{mod}$		
	Flange A	Flange B		CNA Connector nail					
				4,0 x 35	4,0 x 50	4,0 x 60	4,0 x 35	4,0 x 50	4,0 x 60
Nailing pattern 3	10	8	P	2,9	4,7	5,2	6,1	8,1	8,7
			L	3,4	5,2	5,5	7,1	9,5	10,1
			M	3,9	5,2	6,5	8,1	10,8	11,5
			S	4,4	5,7	7,4	9,1	12,2	13,0
			I	5,2	7,2	9,1	11,2	14,9	15,9

2 Angle Brackets ES11/100 per connection			Modified characteristic capacity per connection (kN)						
Nailing pattern	Number of fasteners		Load duration	$R_{1,k} \times k_{mod}$			$R_{2/3,k} \times k_{mod}$		
	Flange A	Flange B		CNA Connector nail					
				4,0 x 35	4,0 x 50	4,0 x 60	4,0 x 35	4,0 x 50	4,0 x 60
Nailing pattern 4	13	10	P	3,7	4,2	5,6	8,8	11,7	12,5
			L	3,7	5,1	6,4	10,2	13,6	14,5
			M	3,7	6,1	6,4	11,7	15,6	16,6
			S	3,8	6,4	6,4	13,2	17,5	18,7
			I	5,0	6,4	6,4	16,1	21,4	22,8

2 Angle Brackets ES11/120 per connection			Modified characteristic capacity per connection (kN)						
Nailing pattern	Number of fasteners		Load duration	$R_{1,k} \times k_{mod}$			$R_{2/3,k} \times k_{mod}$		
	Flange A	Flange B		CNA Connector nail					
				4,0 x 35	4,0 x 50	4,0 x 60	4,0 x 35	4,0 x 50	4,0 x 60
Nailing pattern 4	15	12	P	4,4	5,0	6,8	10,4	13,9	14,8
			L	4,6	6,2	8,0	12,2	16,2	17,3
			M	4,6	7,3	8,0	13,9	18,5	19,8
			S	4,6	8,0	8,0	15,7	20,9	22,2
			I	6,0	8,0	8,0	19,1	25,5	27,2

2 Angle Brackets ES11/140 per connection				Modified characteristic capacity per connection (kN)					
Nailing pattern	Number of fasteners		Load duration	$R_{1,k} \times k_{mod}$			$R_{2/3,k} \times k_{mod}$		
	Flange A	Flange B		CNA Connector nail					
				4,0 x 35	4,0 x 50	4,0 x 60	4,0 x 35	4,0 x 50	4,0 x 60
Nailing pattern 4	17	14	P	5,2	5,8	7,8	14,1	18,8	20,0
			L	5,2	7,2	9,1	16,5	21,9	23,4
			M	5,2	8,6	9,1	18,8	25,0	26,7
			S	5,3	9,1	9,1	21,2	28,2	30,0
			I	7,0	9,1	9,1	25,9	34,4	36,7

2 Angle Brackets ES11/160 per connection				Modified characteristic capacity per connection (kN)					
Nailing pattern	Number of fasteners		Load duration	$R_{1,k} \times k_{mod}$			$R_{2/3,k} \times k_{mod}$		
	Flange A	Flange B		CNA Connector nail					
				4,0 x 35	4,0 x 50	4,0 x 60	4,0 x 35	4,0 x 50	4,0 x 60
Nailing pattern 4	20	16	P	5,9	6,6	9,0	16,2	21,6	23,0
			L	6,1	8,2	10,6	18,9	25,2	26,8
			M	6,1	9,8	10,6	21,6	28,7	30,7
			S	6,1	10,6	10,6	24,3	32,3	34,5
			I	8,0	10,6	10,6	29,7	39,5	42,2

2 Angle Brackets ES11/180 per connection				Modified characteristic capacity per connection (kN)					
Nailing pattern	Number of fasteners		Load duration	$R_{1,k} \times k_{mod}$			$R_{2/3,k} \times k_{mod}$		
	Flange A	Flange B		CNA Connector nail					
				4,0 x 35	4,0 x 50	4,0 x 60	4,0 x 35	4,0 x 50	4,0 x 60
Nailing pattern 4	23	18	P	6,6	7,5	10,1	20,4	27,2	29,1
			L	6,7	9,2	11,7	23,9	31,8	33,9
			M	6,7	11,0	11,7	27,3	36,3	38,7
			S	6,8	11,7	11,7	30,7	40,9	43,6
			I	9,0	11,7	11,7	37,5	49,9	53,3

2 Angle Brackets ES11/200 per connection				Modified characteristic capacity per connection (kN)					
Nailing pattern	Number of fasteners		Load duration	$R_{1,k} \times k_{mod}$			$R_{2/3,k} \times k_{mod}$		
	Flange A	Flange B		CNA Connector nail					
				4,0 x 35	4,0 x 50	4,0 x 60	4,0 x 35	4,0 x 50	4,0 x 60
Nailing pattern 4	25	20	P	7,4	8,3	11,2	22,8	30,4	32,4
			L	7,6	10,3	13,3	26,7	35,5	37,8
			M	7,6	12,2	13,3	30,5	40,6	43,3
			S	7,6	13,3	13,3	34,3	45,7	48,7
			I	10,0	13,3	13,3	41,9	55,8	59,5

## Annex D25 – LS30, LS50, LS70 & LS90

### Product Name:

Product Name	Material reference acc. to clause II-1	Alternative product names
LS30	Steel ref. 4, G90	-
LS50	Steel ref. 4, G90	-
LS70	Steel ref. 4, G90	-
LS90	Steel ref. 4, G90	-

### Connector Size Range:

Model no.	Dimensions [mm]				Holes flange A	Holes flange B
	A	B	C	Thickness	Ø7,14x3,96	Ø7,14x3,96
LS30	57,2	41,6	85,7	1,2	3	3
LS50	57,2	41,6	123,8	1,2	4	4
LS70	57,2	41,6	161,9	1,2	5	5
LS90	57,2	41,6	200,0	1,2	6	6

### Drawing:

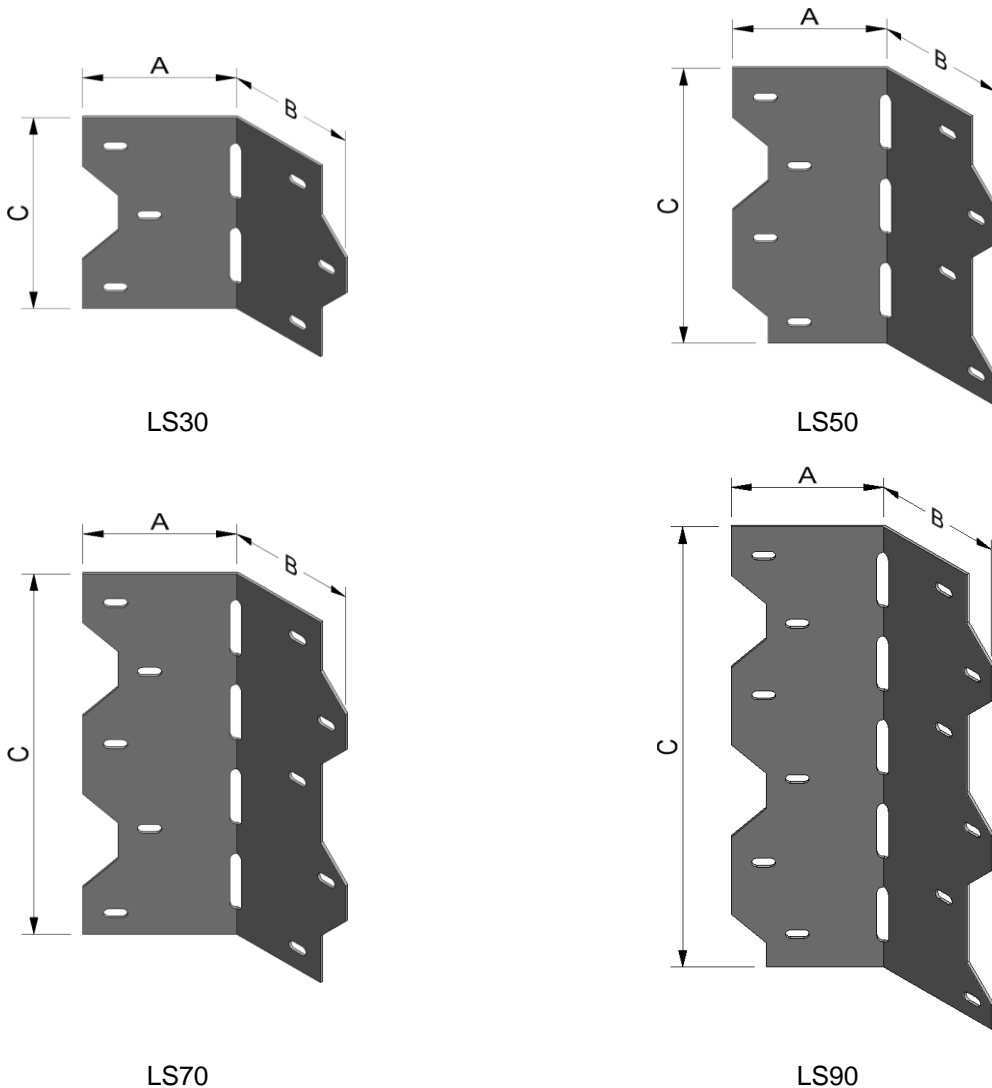

**Nailing pattern:**

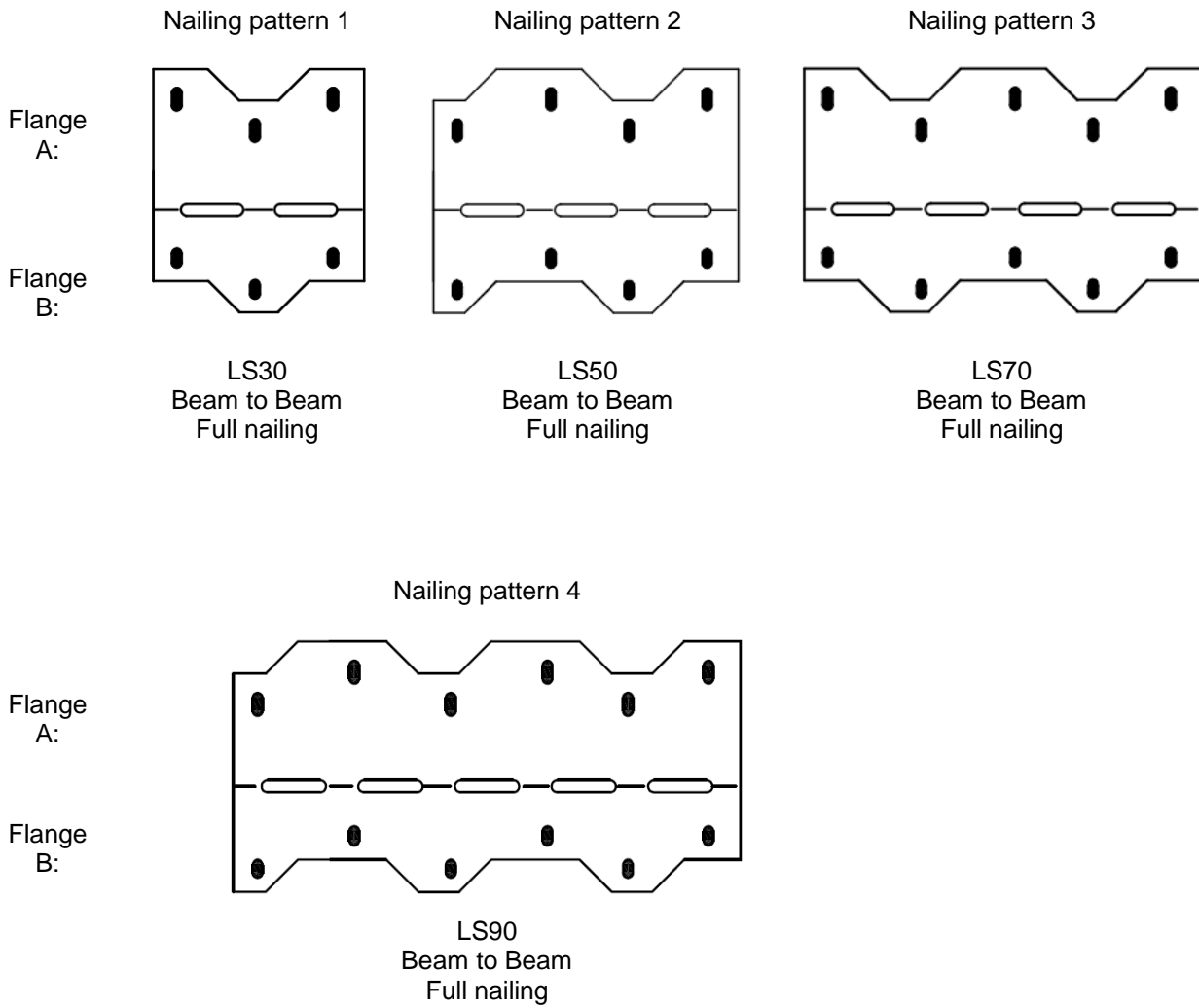

**Design Basis:**

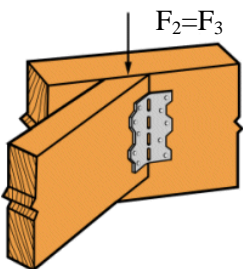

*One angle bracket per connection*

Acting forces

$F_2=F_3$  The force is acting in the bending line of the angle bracket and parallel to it.

Table D25-1 Modified characteristic capacity timber beam to timber beam – 1 Angle Bracket

1 Angle Bracket LS30 per connection				Modified characteristic capacity per connection (kN)	
Nailing pattern	Number of fasteners		Load duration	$R_{2/3,k} \times k_{mod}$	
	Flange A	Flange B		Round smooth nail 3,75 x 75	CNA Connector nail 3,7 x 50
Nailing pattern 1	3	3	P	1,0	1,7
			L	1,2	2,0
			M	1,4	2,3
			S	1,6	2,6
			I	1,9	3,1

1 Angle Bracket LS50 per connection				Modified characteristic capacity per connection (kN)	
Nailing pattern	Number of fasteners		Load duration	$R_{2/3,k} \times k_{mod}$	
	Flange A	Flange B		Round smooth nail 3,75 x 75	CNA Connector nail 3,7 x 50
Nailing pattern 2	4	4	P	1,6	2,6
			L	1,8	3,0
			M	2,1	3,4
			S	2,4	3,9
			I	2,9	4,7

1 Angle Bracket LS70 per connection				Modified characteristic capacity per connection (kN)	
Nailing pattern	Number of fasteners		Load duration	$R_{2/3,k} \times k_{mod}$	
	Flange A	Flange B		Round smooth nail 3,75 x 75	CNA Connector nail 3,7 x 50
Nailing pattern 3	5	5	P	1,6	2,6
			L	1,9	3,1
			M	2,2	3,5
			S	2,4	4,0
			I	3,0	4,9

1 Angle Bracket LS90 per connection				Modified characteristic capacity per connection (kN)	
Nailing pattern	Number of fasteners		Load duration	$R_{2/3,k} \times k_{mod}$	
	Flange A	Flange B		Round smooth nail 3,75 x 75	CNA Connector nail 3,7 x 50
Nailing pattern 4	6	6	P	1,9	3,1
			L	2,2	3,7
			M	2,6	4,2
			S	2,9	4,7
			I	3,5	5,8



## Annex D26 – TA9Z & TA10Z

### Product Name:

Product Name	Material reference acc. to clause II-1	Alternative product names
TA9Z	Steel ref. 4, G185	-
TA10Z	Steel ref. 4, G185	-

### Connector Size Range:

Model no.	Dimensions [mm]				Holes flange A	Holes flange B
	A	B	C	Thickness	Ø7	Ø7
TA9Z	41	41	210	2,5	3	2
TA10Z	41	41	260	2,5	4	3

### Drawing:

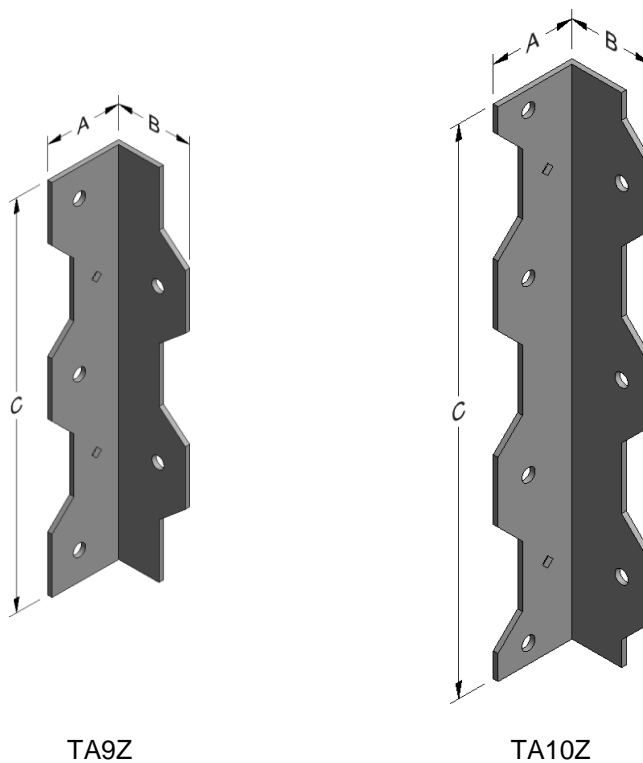

**Nailing pattern:**

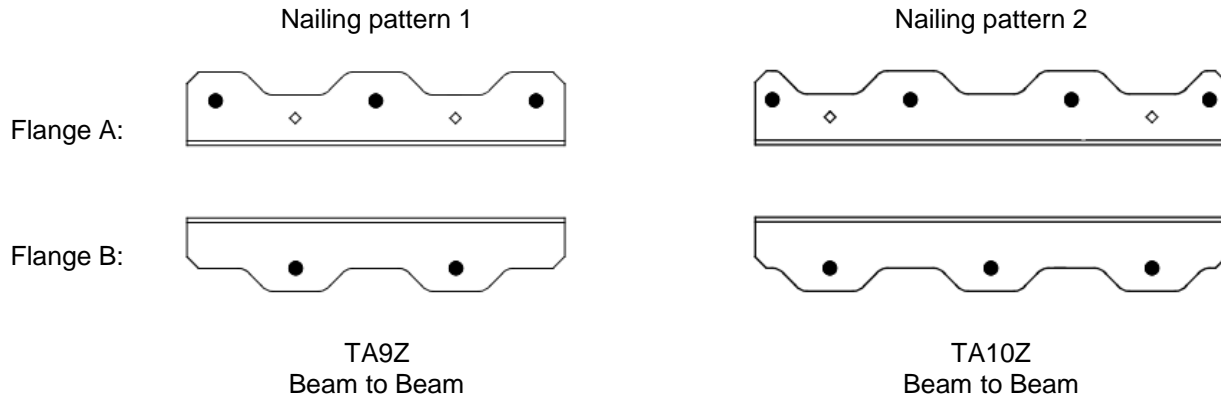

**Design basis:**

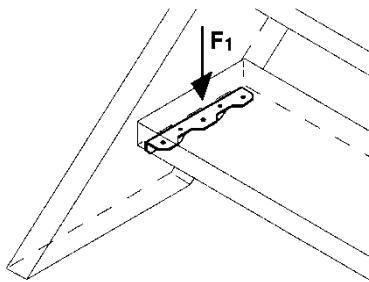

*One angle bracket per connection*  
 Acting forces  
 $F_1$  Downward force from the step acting close to the string

Typical installation – Design basis

Table D26-1 Modified characteristic capacity timber beam to timber beam – 1 angle bracket

1 Angle Bracket per connection				Modified characteristic capacity per connection (kN)	
Type	Nailing pattern	Number of fasteners		Load duration	$R_{1,k} \times k_{mod}$
		Flange A	Flange B		Smooth shank screws 6,0 x 45 in pre-drilled holes
TA9Z	Nailing pattern 1	3	2	P	3,8
				L	4,5
				M	5,2
				S	5,9
				I	7,3
TA10Z	Nailing pattern 2	4	3	P	5,1
				L	6,0
				M	6,9
				S	7,9
				I	9,7

## Annex D27 – ABR170 & ABR 220

### Product Name:

Product Name	Material reference acc. to clause II-1	Alternative product names
ABR170	Steel ref. 1	-
ABR220	Steel ref. 1	-
ABR170S	Steel ref. 2	-
ABR220S	Steel ref. 2	-
ABR170S2	Steel ref. 3	-
ABR220S2	Steel ref. 3	-

### Connector Size Range:

Model no.	Dimensions [mm]				Holes flange A		Holes flange B	
	A	B	C	Thickness	Ø5	Ø12	Ø5	Ø12
ABR170	170	40	95	2,0	20	2	9	2
ABR220	220	40	95	2,0	24	2	9	2

### Drawing:

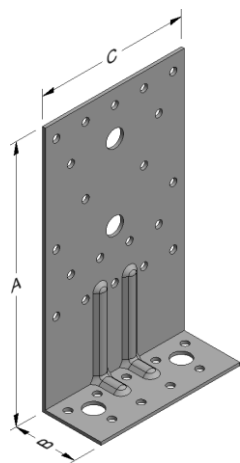

ABR170

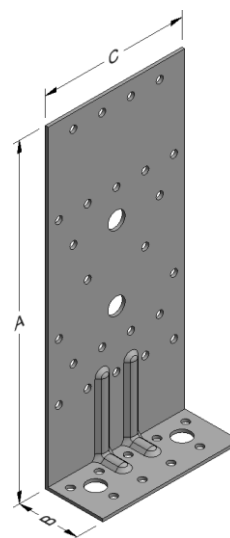

ABR220

**Nailing pattern:**

For a combination of different force directions, it's to use the nail pattern with the most nails.

Nailing pattern 1

Nailing pattern 2

Nailing pattern 3

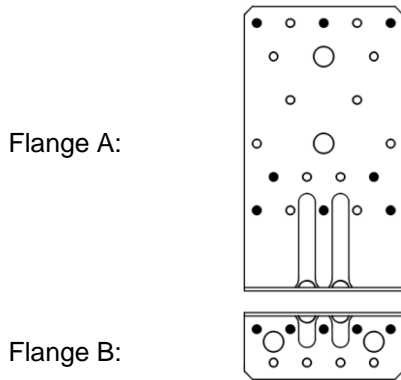

ABR170 and ABR220  
Beam/column to beam  
For force  $F_1$

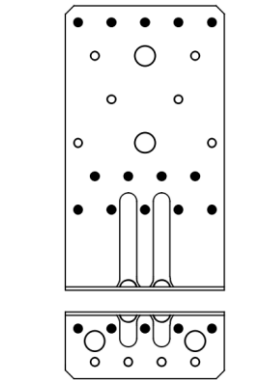

ABR170 and ABR220  
Beam/column to beam  
For force  $F_{2/3}$

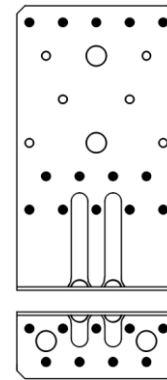

ABR170 and ABR220  
Beam/column to beam  
For force  $F_{4/5}$

Nailing pattern 4

Nailing pattern 5

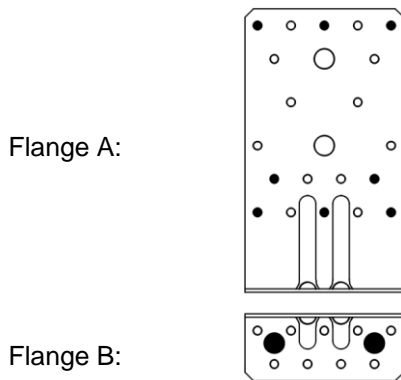

ABR170 and ABR220  
Beam/column to rigid  
For force  $F_1$

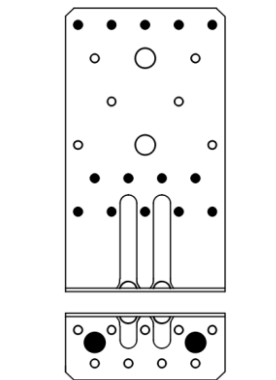

ABR170 and ABR220  
Beam/column to rigid  
For force  $F_{2/3}$  and  $F_{4/5}$

**Table D27-1 Modified characteristic capacity timber beam/column to timber beam – 2 Angle Brackets Load duration M**

2 Angle Brackets ABR170 or ABR220 per connection				Modified characteristic capacity per connection (kN)			
Nailing pattern	Number of fasteners		Load duration		CNA Connector nail		
	Flange A	Flange B			4,0x40	4,0x50	4,0x60
Nailing pattern 1	8	5	M	$R_{1,k} \times k_{mod}$	5,9	7,8	9,8
Nailing pattern 2	14	5		$R_{2/3,k} \times k_{mod}$	13,1	15,8	16,9
Nailing pattern 3	14	9		$R_{4/5,k} \times k_{mod}$	8,0 with $e \leq 50$ mm $b \geq 36$ mm or $e \leq 90$ mm $b \geq 60$ mm	8,0 with $e \leq 65$ mm $b \geq 36$ mm or $e \leq 120$ mm $b \geq 60$ mm	8,0 with $e \leq 80$ mm $b \geq 36$ mm or $e \leq 150$ mm $b \geq 60$ mm

**Table D27-2 Modified characteristic capacity timber beam/column to timber beam – 1 Angle Bracket Load duration M**

1 Angle Bracket ABR170 or ABR220 per connection				Modified characteristic capacity per connection (kN)			
Nailing pattern	Number of fasteners		Load duration		CNA Connector nail		
	Flange A	Flange B			4,0x40	4,0x50	4,0x60
Nailing pattern 1	8	5	M	$R_{1,k} \times k_{mod}$	2,9	3,9	4,9
Nailing pattern 2	14	5		$R_{2/3,k} \times k_{mod}$	6,6	7,9	8,5
Nailing pattern 3	14	9		$R_{4,k} \times k_{mod}$	0,7 with $e \leq 50$ mm	0,7 with $e \leq 50$ mm	0,7 with $e \leq 50$ mm
Nailing pattern 3	14	9		$R_{4,k} \times k_{mod}$	Capacity for a connection, without rotation of purlin: 6,6		
Nailing pattern 3	14	9		$R_{5,k} \times k_{mod}$	1,4 with $e \leq 50$ mm $b \geq 36$ mm or $e \leq 90$ mm $b \geq 60$ mm	1,4 with $e \leq 65$ mm $b \geq 36$ mm or $e \leq 120$ mm $b \geq 60$ mm	1,4 with $e \leq 80$ mm $b \geq 36$ mm or $e \leq 150$ mm $b \geq 60$ mm

Factors for other Load durations:

Factors for other load durations	R <sub>1,k</sub>			R <sub>2/3,k</sub>	R <sub>4,k</sub>	R <sub>4,k</sub> <sup>1)</sup>	R <sub>5,k</sub>	R <sub>4/5,k</sub>
	CNA Connector nail			All sizes				
	4,0x40	4,0x50	4,0x60					
I multiply M by	1,38	1,33	1,23	1,38	1	1,38	1	1,31
S multiply M by	1,13	1,13	1,08	1,13	1	1,13	1	1,1
L multiply M by	0,88	0,88	0,88	0,88	1	0,88	1	0,9
P multiply M by	0,75	0,75	0,75	0,75	1	0,75	1	0,79

1) capacity for a connection, without rotation of purlin

Table D27-3 Characteristic capacity timber beam/column to rigid – 2 Angle Brackets

2 Angle Brackets ABR170 or ABR220 per connection			Characteristic capacity per connection (kN)			
Nailing pattern	Number of fasteners			CNA Connector nail		
	Flange A	Flange B		4,0x40	4,0x50	4,0x60
Nailing pattern 4	8	2 Bolts	R <sub>1,k</sub>	$\min \left\{ \begin{matrix} 33,0 \\ 25,2 \\ k_{mod} \end{matrix} \right.$	$\min \left\{ \begin{matrix} 39,8 \\ 25,2 \\ k_{mod} \end{matrix} \right.$	$\frac{25,2}{k_{mod}}$
Nailing pattern 5	14	2 Bolts	R <sub>2/3,k</sub>	19,71	$\min \left\{ \begin{matrix} 23,8 \\ 24,6 \\ k_{mod} \end{matrix} \right.$	$\min \left\{ \begin{matrix} 25,4 \\ 24,6 \\ k_{mod} \end{matrix} \right.$
Nailing pattern 5	14	2 Bolts	R <sub>4/5,k</sub>	the minimum of e is 50 mm	$\min \left\{ \begin{matrix} 9,15 + \frac{80}{e \times k_{mod}} \\ 6,3 \times b \\ e \times k_{mod} \end{matrix} \right.$	

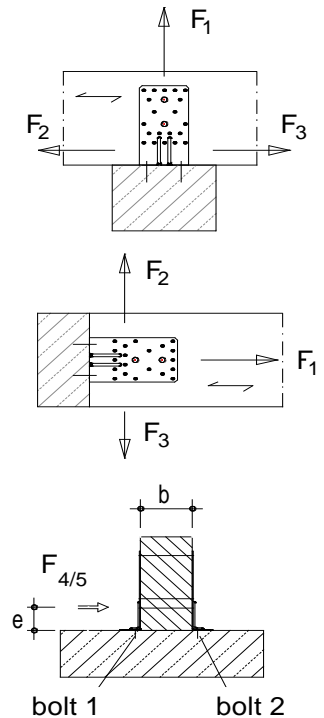

For connection with 2 Angle Brackets it must be checked:

- for R<sub>1</sub>:  $R_{bolt,ax,d} \geq F_{1,d} / n_{bolt}$
- for R<sub>2/3</sub>:  $R_{bolt,lat,d} \geq F_{2/3,d} / n_{bolt}$
- for R<sub>4/5</sub>: Bolt 1:  $R_{bolt,ax,d} \geq F_{4/5,d} \times e / (2 \times b)$   
 Bolt 2:  $R_{bolt,lat,d} \geq F_{4/5,d} / 2$   
 $R_{4/5,d} \leq R_{1,d} \times b / (2 \times e)$

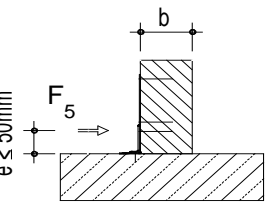
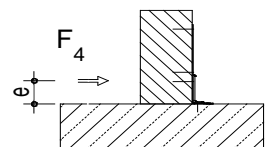
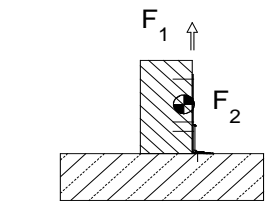

In case of combined force the relevant of the following inequalities shall be fulfilled:

$$\left( \frac{F_{1,d}}{R_{1,d}} + \frac{F_{4/5,d}}{R_{4/5,d}} \right)^2 + \left( \frac{F_{2/3,d}}{R_{2/3,d}} \right) \leq 1$$

For F<sub>4/5</sub> can be use also F<sub>4</sub> or F<sub>5</sub> too, also for F<sub>2/3</sub> can be use F<sub>2</sub> or F<sub>3</sub> too.

**Table D27-4 Characteristic capacity timber beam/column to rigid – 1 Angle Bracket**

1 Angle Bracket ABR170 or ABR220 per connection			Characteristic capacity per connection (kN)			
Nailing pattern	Number of fasteners			CNA Connector nail		
	Flange A	Flange B		4,0x40	4,0x50	4,0x60
Nailing pattern 4	8	2 Bolts	$R_{1,k}$	$\min \begin{cases} 16,5 \\ \frac{12,6}{k_{mod}} \end{cases}$	$\min \begin{cases} 19,9 \\ \frac{12,6}{k_{mod}} \end{cases}$	$\frac{12,6}{k_{mod}}$
Nailing pattern 5	14	2 Bolts	$R_{2/3,k}$	9,86	$\min \begin{cases} 11,9 \\ \frac{12,3}{k_{mod}} \end{cases}$	$\min \begin{cases} 12,7 \\ \frac{12,3}{k_{mod}} \end{cases}$
Nailing pattern 5	14	2 Bolts	$R_{4,k}$	$\frac{50}{e \times k_{mod}}$ $\frac{36}{e \times k_{mod}}$		
Nailing pattern 5	14	2 Bolts	$R_{5,k}$	$\frac{1,8}{k_{mod}}$		

For connection with one Angle Bracket it must be checked:

- for  $R_1$ :  $R_{bolt,ax,d} \geq F_{1,d} / n_{bolt}$
- for  $R_{2/3}$ :  $R_{bolt,lat,d} \geq F_{2/3,d} / n_{bolt}$
- for  $R_5$ :  $R_{bolt,ax,d} \geq F_{5,d} \times e / (2 \times b)$
- for  $R_{4 \text{ or } 5}$ :  $F_{4 \text{ or } 5,d} / 2$

In case of combined force the relevant of the following inequalities shall be fulfilled:

$$\left( \frac{F_{1,d}}{R_{1,d}} + \frac{F_{4/5,d}}{R_{4/5,d}} \right)^2 + \left( \frac{F_{2/3,d}}{R_{2/3,d}} \right) \leq 1$$

For  $F_{4/5}$  can be use also  $F_4$  or  $F_5$  too, also for  $F_{2/3}$  can be use  $F_2$  or  $F_3$  too.

## Annex D28 – AB6983

### Product Name:

Product Name	Material reference acc. to clause II-1	Alternative product names
AB6983	Steel ref. 1	-
AB6983S	Steel ref. 2	-
AB6983S2	Steel ref. 3	-

### Connector Size Range:

Model no.	Dimensions [mm]				Holes flange A	Holes flange B
	A	B	C	Thickness	Ø4	Ø13
AB6983	69	83	300	2,5	14	2

### Drawing:

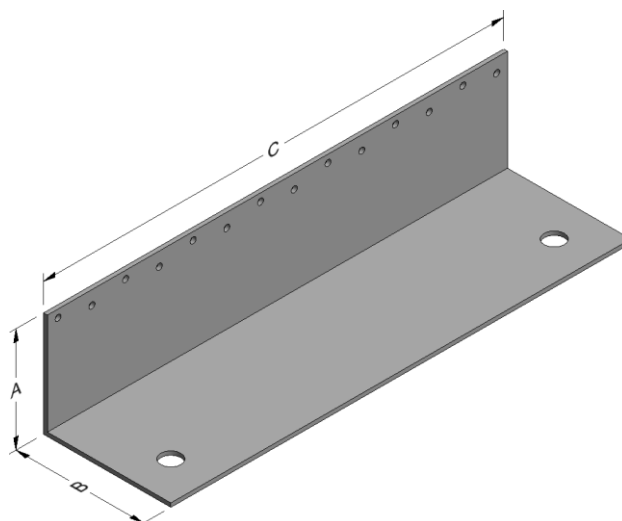

### Nailing pattern:

Nailing pattern 1

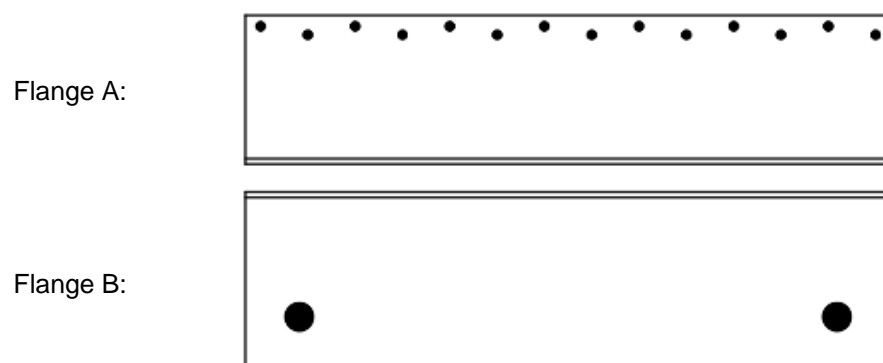

Timber to rigid



**Modified characteristic capacity per connection (one shear connector per connection):**

$$R_{2/3} \times k_{\text{mod}} = \min \begin{cases} R_{\text{lat.nail.k}} \times 9,29 \times k_{\text{mod}} \\ R_{\text{lat.bolt.k}} \times 2,14 \end{cases}$$

The capacity of the connection between the bolts and concrete has to be checked separately

Fasteners: 14 threaded nails CNA3,1xℓ and 2 bolts Ø12 mm. (Nailing pattern 1)

$R_{\text{lat.nail.k}}$  = Characteristic lateral capacity of 1 threaded nail CNA3,1xℓ

$R_{\text{lat.bolt.k}}$  = Characteristic lateral capacity of 1 M12 bolt. max. 7,5 kN

$k_{\text{mod}}$  = Strength modification factor for service class and load-duration class according to Eurocode 5.

## Annex D29 – AB36125

### Product Name:

Product Name	Material reference acc. to clause II-1	Alternative product names
AB36125	Steel ref. 1	-
AB36125S	Steel ref. 2	-
AB36125S2	Steel ref. 3	-

### Connector Size Range:

Model no.	Dimensions [mm]				Holes flange A	Holes flange B
	A	B	C	Thickness	Ø5	Ø5
AB36125	36	125	247	2,0	9	34

### Drawing:

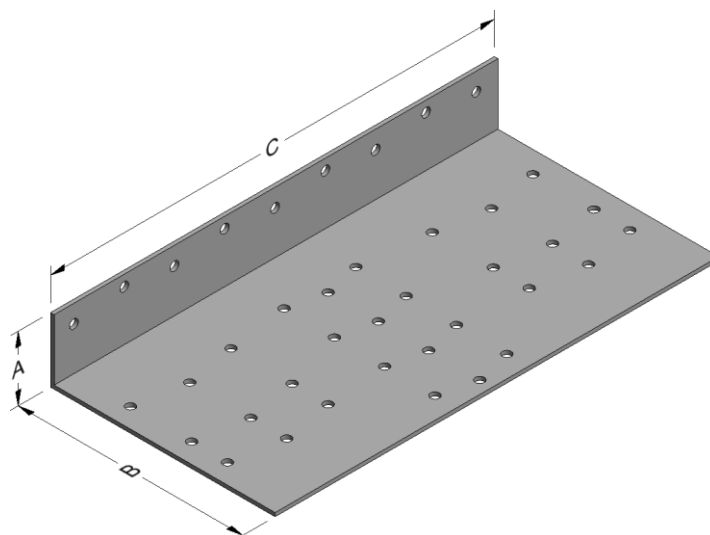

**Nailing pattern:**

Nailing pattern 1

Nailing pattern 2

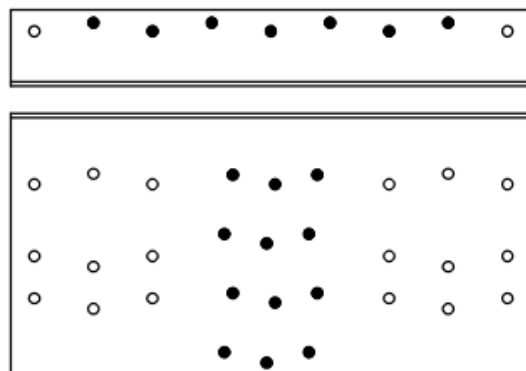
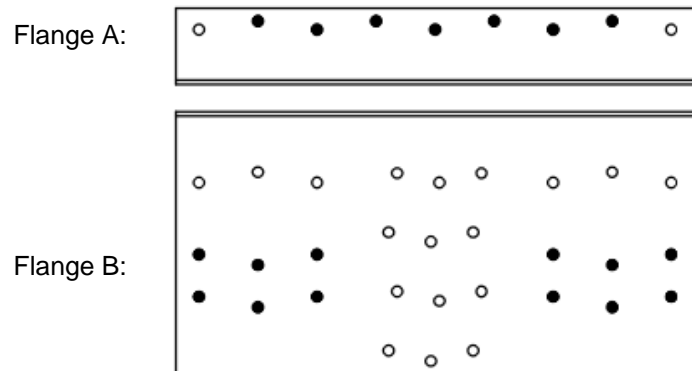

Timber to timber

Timber to timber

Nailing pattern 3

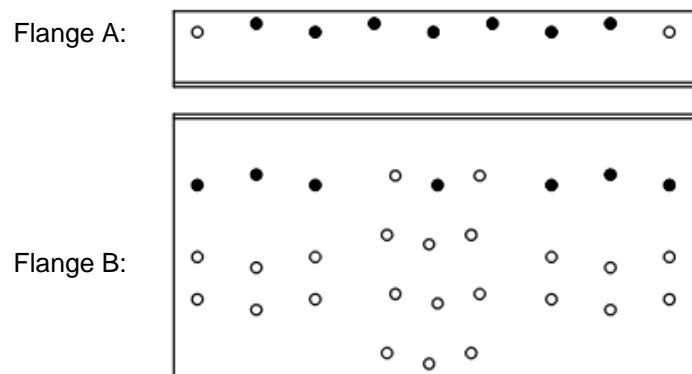

Timber to timber

**Modified characteristic capacity per connection (one shear connector per connection):**

Fasteners: 7 + 12 (Nailing pattern 1):

$$R_{2/3} \times k_{\text{mod}} = \min \begin{cases} R_{\text{lat,nail-v,k}} \times 5,60 \times k_{\text{mod}} \\ R_{\text{lat,nail-h,k}} \times 8,57 \times k_{\text{mod}} \end{cases}$$

Fasteners: 7 + 12 (Nailing pattern 2):

$$R_{2/3} \times k_{\text{mod}} = \min \begin{cases} R_{\text{lat,nail-v,k}} \times 5,60 \times k_{\text{mod}} \\ R_{\text{lat,nail-h,k}} \times 6,04 \times k_{\text{mod}} \end{cases}$$

Fasteners: 7 + 7 (Nailing pattern 3):

$$R_{2/3} \times k_{\text{mod}} = \min \begin{cases} R_{\text{lat,nail-v,k}} \times 5,60 \times k_{\text{mod}} \\ R_{\text{lat,nail-h,k}} \times 6,12 \times k_{\text{mod}} \end{cases}$$

$R_{\text{lat,nail-v,k}}$  = Characteristic lateral capacity of 1 threaded nail CNA4,0xℓ in the vertical flange

$R_{\text{lat,nail-h,k}}$  = Characteristic lateral capacity of 1 threaded nail CNA4,0xℓ in the horizontal flange

$k_{\text{mod}}$  = Strength modification factor for service class and load-duration class according to Eurocode 5.

## Annex D30 – BNV33

### Product Name:

Product Name	Material reference acc. to clause II-1	Alternative product names
BNV33	Steel ref. 1	-
BNV33S	Steel ref. 2	-
BNV33S2	Steel ref. 3	-

### Connector Size Range:

Model no.	Dimensions [mm]				Holes flange A			Holes flange B		
	A	B	C	Thickness	Ø5	Ø8,5	Ø11	Ø5	Ø8,5	Ø13
BNV33	62,5	34,5	180	1,5	13	6	2	7	4	2

### Drawing:

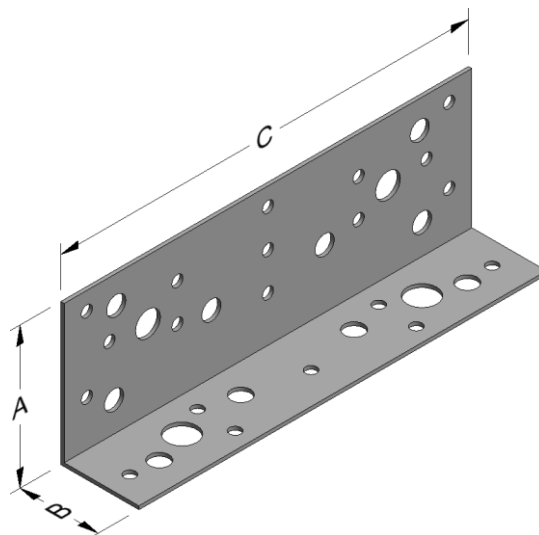

### Nailing pattern:

Nailing pattern 1

Nailing pattern 2

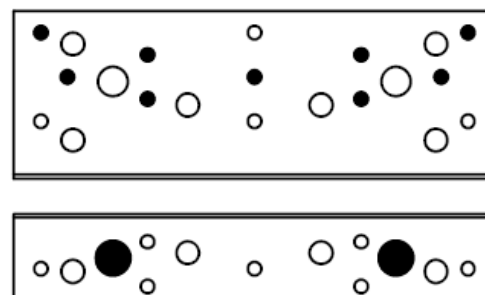
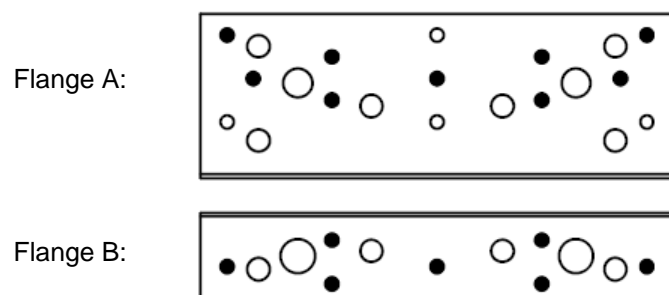

Timber to timber

Timber to rigid

**Modified characteristic capacity per connection (one shear connector per connection):**

Fasteners: 9+7 (Nailing pattern 1):

$$R_{2/3} \times k_{\text{mod}} = \min \begin{cases} R_{\text{lat,nail-v,k}} \times 5,82 \times k_{\text{mod}} \\ R_{\text{lat,nail-h,k}} \times 6,26 \times k_{\text{mod}} \end{cases}$$

Fasteners: 9+2 (Nailing pattern 2)

$$R_{2/3} \times k_{\text{mod}} = \min \begin{cases} R_{\text{lat,nail,k}} \times 5,82 \times k_{\text{mod}} \\ R_{\text{lat,bolt,k}} \times 2,24 \times k_{\text{mod}} \end{cases}$$

The capacity of the connection between the bolts and concrete has to be checked separately

$R_{\text{lat,nail-v,k}}$  = Characteristic lateral capacity of 1 threaded nail CNA4,0xℓ in the vertical flange

$R_{\text{lat,nail-h,k}}$  = Characteristic lateral capacity of 1 threaded nail CNA4,0xℓ in the horizontal flange

$R_{\text{lat,nail,k}}$  = Characteristic lateral capacity of 1 threaded nail CNA4,0xℓ

$R_{\text{lat,bolt,k}}$  = Characteristic lateral capacity of 1 M12 bolt, max. 4,5 kN

$k_{\text{mod}}$  = Strength modification factor for service class and load-duration class according to Eurocode 5.

## Annex D31 – E5/1.5

### Product Name:

Product Name	Material reference acc. to clause II-1	Alternative product names
E5/1.5	Steel ref. 1	-
E5/1.5S	Steel ref. 2	-
E5/1.5S2	Steel ref. 3	-
E5/1.5/11.22/11	Steel ref. 1	-
E5IX/1.5/1122/11	Steel ref. 2	-
E5/1.5/11.22/11S2	Steel ref. 3	-
E5/1.5/13	Steel ref. 1	-
E5/1.5/13S	Steel ref. 2	-
E5/1.5/13S2	Steel ref. 3	-

### Connector Size Range:

Model no.	Dimensions [mm]				Holes flange A			Holes flange B		
	A	B	C	Thickness	Ø5	Ø13	11x22	Ø5	Ø13	11x22
E5/1.5	76,5	49,5	65	1,5	7	0	1	6	0	1
E5/1.5/11.22/11 E5IX/1.5/1122/11	76,5	49,5	65	1,5	7	0	1	6	1	0
E5/1.5/13	76,5	49,5	65	1,5	7	1	0	6	1	0

### Drawing:

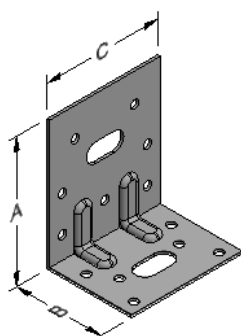

E5/1.5

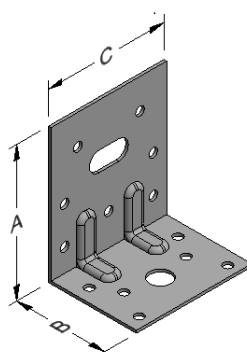

E5/1.5/11.22/11  
E5IX/1.5/1122/11

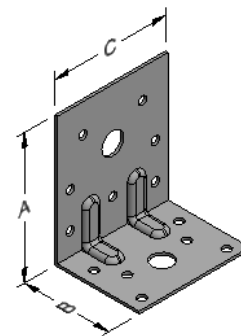

E5/1.5/13

**Nailing pattern:**

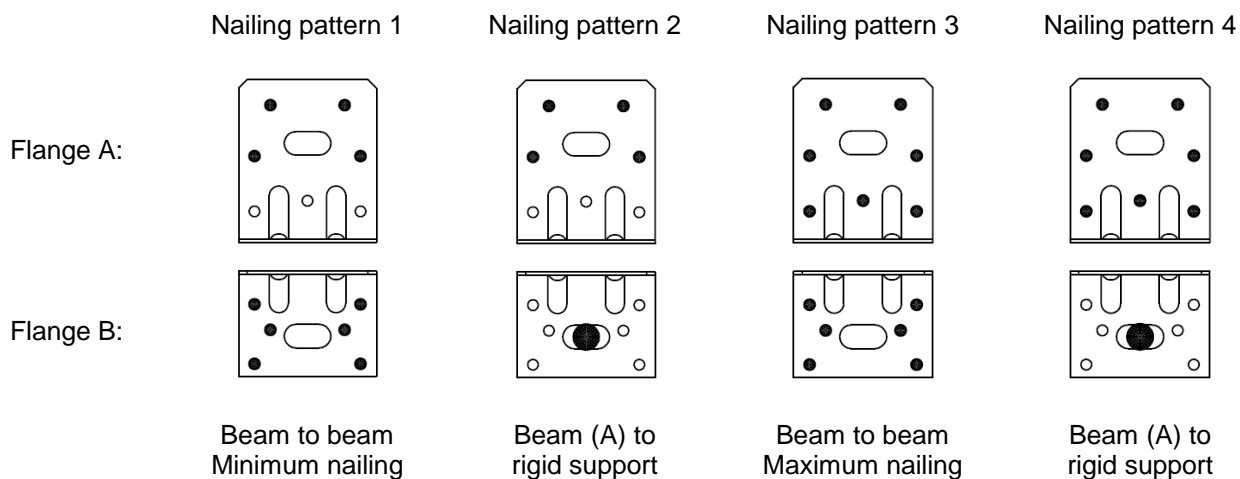



**Table D31-1 Modified characteristic capacity timber beam to timber beam – 1 Angle Bracket E5/1.5 & E5/1.5/11.22/11 & E5IX/1.5/1122/11, Nailing pattern 1**

1 Angle Bracket per connection			Modified characteristic capacity per connection (kN)						
Nailing pattern	Number of fasteners		Load duration	$R_{1,k} \times k_{mod}$		$R_{2/3,k} \times k_{mod}$		$R_{4,k} \times k_{mod}$	
	Flange A	Flange B		4,0x35	4,0x60	4,0x35	4,0x60	4,0x35	4,0x60
Nailing pattern1	4	6	P	$f \leq 6,7$ $28 / (f + 46)$	$f \leq 3,3$ $57 / (f + 46)$	1,5	2,5	Min of $20/(e - 1,5)$ $23/\sqrt{(e^2 + 25)}$	Min of $20/(e - 1,5)$
				$f > 6,7$ $4 / (f + 1)$	$f > 3,3$ $4 / (f + 1)$			3,6 $7,4/(e - 26)$	3,6 $7,4/(e - 26)$
			L	$f \leq 5,5$ $33 / (f + 46)$	$f \leq 2,7$ $67 / (f + 46)$	1,7	2,9	Min of $20/(e - 1,5)$ $28/\sqrt{(e^2 + 25)}$	Min of $20/(e - 1,5)$
				$f > 5,5$ $4 / (f + 1)$	$f > 2,7$ $4 / (f + 1)$			4 $7,4/(e - 26)$	4 $7,4/(e - 26)$
			M	$f \leq 4,6$ $38 / (f + 46)$	$f \leq 2,2$ $76 / (f + 46)$	2	3,3	Min of $20/(e - 1,5)$ $32/\sqrt{(e^2 + 25)}$	Min of $20/(e - 1,5)$
				$f > 4,6$ $4 / (f + 1)$	$f > 2,2$ $4 / (f + 1)$			4,1 $7,4/(e - 26)$	4,1 $7,4/(e - 26)$
			S	$f \leq 3,9$ $43 / (f + 46)$	$f \leq 1,9$ $86 / (f + 46)$	2,2	3,8	Min of $20/(e - 1,5)$ $36/\sqrt{(e^2 + 25)}$	Min of $20/(e - 1,5)$
				$f > 3,9$ $4 / (f + 1)$	$f > 1,9$ $4 / (f + 1)$			4,4 $7,4/(e - 26)$	4,4 $7,4/(e - 26)$
			I	$f \leq 3$ $52 / (f + 46)$	$f \leq 1,4$ $105 / (f + 46)$	2,7	4,6	Min of $20/(e - 1,5)$ $44/\sqrt{(e^2 + 25)}$	Min of $20/(e - 1,5)$
				$f > 3$ $4 / (f + 1)$	$f > 1,4$ $4 / (f + 1)$			4,9 $7,4/(e - 26)$	4,9 $7,4/(e - 26)$

**Table D31-2 Modified characteristic capacity timber beam to timber beam – 2 Angle Brackets E5/1.5 & E5/1.5/11.22/11 & E5IX/1.5/1122/11, Nailing pattern 1**

2 Angle Brackets per connection			Modified characteristic capacity per connection (kN)						
Nailing pattern	Number of fasteners		Load duration	$R_{1,k} \times k_{mod}$		$R_{2/3,k} \times k_{mod}$		$R_{4/5,k} \times k_{mod}$	
	Flange A	Flange B		4,0x35	4,0x60	4,0x35	4,0x60	4,0x35	4,0x60
Nailing pattern 1	4	6	P	2,5	5,0	3,0	4,9	$e \leq 0,32 * b + 15$ 3,9	$e \leq 0,54 * b + 19$ 3,9
								$e > 0,32 * b + 15$ $0,74 * (1,70 * b + 75) / (e - 1,5)$	$e > 0,54 * b + 19$ $0,87 * (2,89 * b + 92) / (e - 1,5)$
			L	3,0	5,6	3,5	5,8	$e \leq 0,34 * b + 15$ 4,3	$e \leq 0,56 * b + 18$ 4,3
								$e > 0,34 * b + 15$ $0,74 * (1,98 * b + 79) / (e - 1,5)$	$e > 0,56 * b + 18$ $0,87 * (3,26 * b + 98) / (e - 1,5)$
			M	3,3	6,2	3,9	6,6	$e \leq 0,37 * b + 15$ 4,6	$e \leq 0,57 * b + 18$ 4,6
								$e > 0,37 * b + 15$ $0,74 * (2,26 * b + 83) / (e - 1,5)$	$e > 0,57 * b + 18$ $0,87 * (3,55 * b + 102) / (e - 1,5)$
			S	3,7	6,7	4,4	7,5	$e \leq 0,39 * b + 15$ 4,8	$e \leq 0,59 * b + 18$ 4,8
								$e > 0,39 * b + 15$ $0,74 * (2,54 * b + 87) / (e - 1,5)$	$e > 0,59 * b + 18$ $0,87 * (3,84 * b + 107) / (e - 1,5)$
			I	4,6	7,7	5,5	9,2	$e \leq 0,43 * b + 15$ 5,4	$e \leq 0,61 * b + 17$ 5,4
								$e > 0,43 * b + 15$ $0,74 * (3,11 * b + 96) / (e - 1,5)$	$e > 0,61 * b + 17$ $0,87 * (4,43 * b + 116) / (e - 1,5)$

**Table D31-3 Modified characteristic capacity timber beam to rigid support – 1 Angle Bracket E5/1.5 & E5/1.5/11.22/11 & E5IX/1.5/1122/11, Nailing pattern 2**

1 Angle Bracket per connection			Modified characteristic capacity per connection (kN)							
Nailing pattern	Number of fasteners		Load duration	$R_{1,k} \times k_{mod}$		$R_{2/3,k} \times k_{mod}$		$R_{4,k} \times k_{mod}$		
	Flange A	Flange B		4,0x35	4,0x60	4,0x35	4,0x60	4,0x35	4,0x60	
Nailing pattern 2	4	1 x Ø10 Bolt	P	Min of 12,1 / (f + 24) 4,1 / f		0,6	1,1	Min of 36,3 / e 8 / (e - 26) 12,9		
			L			0,8	1,3			
			M			0,9	1,5			
			S			1,1	1,7			
			I			1,2	2,1			

**Note:** For  $R_{4,k}$  if the purlin is prevented from rotation, consider the value given for two brackets for  $e=0$ .

Bolt factor	for $F_1$	for $F_{2/3}$	for $F_4$
$k_{ax}$	$(f+38)/8$	0,46	$e/8$
$k_{lat}$	-	1,0	1,0

For each bolt it's needed to check:  $R_{bolt,d,lateral} \geq k_{lat} \times F_{i,d}$  ;  $R_{bolt,d,axial} \geq k_{ax} \times F_{i,d}$  ; and also the combination

**Table D31-4 Modified characteristic capacity timber beam to rigid support – 2 Angle Brackets E5/1.5 & E5/1.5/11.22/11 & E5IX/1.5/1122/11, Nailing pattern 2**

2 Angle Brackets per connection			Modified characteristic capacity per connection (kN)						
Nailing pattern	Number of fasteners		Load duration	$R_{1,k} \times k_{mod}$		$R_{2/3,k} \times k_{mod}$		$R_{4/5,k} \times k_{mod}$	
	Flange A	Flange B		4,0x35	4,0x60	4,0x35	4,0x60	4,0x35	4,0x60
Nailing pattern 2	4	1 x Bolt Ø10	P	2,3	4,4	1,3	2,0	$e \leq 0,26 * b + 21$	$e \leq 0,42 * b + 25$
								4,4	4,4
			L	2,7	5,1	1,6	2,6	$e > 0,26 * b + 21$	$e > 0,42 * b + 25$
								$0,74 * (1,54 * b + 107) / (e - 1,5)$	$0,87 * (2,53 * b + 132) / (e - 1,5)$
			M	3,0	5,5	1,8	3,0	$e \leq 0,28 * b + 20$	$e \leq 0,46 * b + 25$
								4,8	4,8
			S	3,4	5,5	2,1	3,3	$e > 0,28 * b + 20$	$e > 0,46 * b + 25$
								$0,74 * (1,80 * b + 114) / (e - 1,5)$	$0,87 * (2,96 * b + 143) / (e - 1,5)$
			I	4,1	5,5	2,5	4,1	$e \leq 0,30 * b + 20$	$e \leq 0,49 * b + 25$
								5,1	5,1
			I	4,1	5,5	2,5	4,1	$e > 0,30 * b + 20$	$e > 0,49 * b + 25$
								$0,74 * (2,05 * b + 120) / (e - 1,5)$	$0,87 * (3,38 * b + 153) / (e - 1,5)$
I	4,1	5,5	2,5	4,1	$e \leq 0,31 * b + 20$	$e \leq 0,52 * b + 25$			
					5,5	5,5			
I	4,1	5,5	2,5	4,1	$e > 0,31 * b + 20$	$e > 0,52 * b + 25$			
					$0,74 * (2,31 * b + 126) / (e - 1,5)$	$0,87 * (3,80 * b + 154) / (e - 1,5)$			
I	4,1	5,5	2,5	4,1	$e \leq 0,35 * b + 20$	$e \leq 0,57 * b + 26$			
					6,0	6,0			
I	4,1	5,5	2,5	4,1	$e > 0,35 * b + 20$	$e > 0,57 * b + 26$			
					$0,74 * (2,82 * b + 139) / (e - 1,5)$	$0,87 * (4,65 * b + 185) / (e - 1,5)$			

**Note:** Value given for a withdrawal characteristic capacity of the bolt of 16 kN. For others bolt withdrawal capacities  $R_{k,anchor}$  (kN), value must be limited by  $13.6 * R_{k,anchor} / 16$

Bolt factor	for $F_1$	for $F_{2/3}$	for $F_{4/5}$ , bolt 1	for $F_{4/5}$ , bolt 2
$k_{ax}$	0,98	0,23	$1,96 * e / (b + 25)$	-
$k_{lat}$	-	0,50	-	1,00

For each bolt it's needed to check:  $R_{bolt,d,lateral} \geq k_{lat} \times F_{i,d}$  ;  $R_{bolt,d,axial} \geq k_{ax} \times F_{i,d}$ ; and also the combination

*Table D31-5 Modified characteristic capacity timber beam to rigid support – 1 Angle Bracket, Nailing pattern 2*

1 Angle Bracket E5/1.5/13 per connection			Modified characteristic capacity per connection (kN)							
Nailing pattern	Number of fasteners		Load duration	$R_{1,k} \times k_{mod}$		$R_{2/3,k} \times k_{mod}$		$R_{4,k} \times k_{mod}$		
	Flange A	Flange B		4,0x35	4,0x60	4,0x35	4,0x60	4,0x35	4,0x60	
Nailing pattern 2	4	1 x Ø10 Bolt	P	Min of 13,6 / (f + 23)  5,2 / f		0,6	1	Min of 36,3 / e  8 / (e - 26)  19,3		
			L			0,8	1,3			
			M			0,9	1,5			
			S			1,1	1,7			
			I			1,2	2,1			

Note: For  $R_{4,k}$  if the purlin is prevented from rotation, consider the value given for two brackets for  $e=0$ .

Bolt factor	for $F_1$	for $F_{2/3}$	for $F_4$
$k_{ax}$	$(f + 38) / 8$	0,46	$e / 8$
$k_{lat}$	-	1,0	1,0

For each bolt it's needed to check:  $R_{bolt,d,lateral} \geq k_{lat} \times F_{i,d}$  ;  $R_{bolt,d,axial} \geq k_{ax} \times F_{i,d}$  ; and also the combination

Table D31-6 Modified characteristic capacity timber beam to rigid support – 2 Angle Brackets, Nailing pattern 2

2 Angle Brackets E5/1.5/13 per connection			Modified characteristic capacity per connection (kN)						
Nailing pattern	Number of fasteners		Load duration	R <sub>1,k</sub> x k <sub>mod</sub>		R <sub>2/3,k</sub> x k <sub>mod</sub>		R <sub>4/5,k</sub> x k <sub>mod</sub>	
	Flange A	Flange B		4,0x35	4,0x60	4,0x35	4,0x60	4,0x35	4,0x60
Nailing pattern 2	4	1 x Ø10 Bolt	P	2,4	4,7	1,3	2,2	e ≤ 0,27 * b + 21	e ≤ 0,44 * b + 25
								4,4	4,4
			L	2,8	5,4	1,6	2,6	e > 0,27 * b + 21	e > 0,44 * b + 25
								0,74*(1,63*b+109)/(e-1,5)	0,87*(2,67*b+136)/(e-1,5)
			M	3,2	5,9	1,8	3,0	e ≤ 0,29 * b + 21	e ≤ 0,48 * b + 25
								4,8	4,8
			S	3,6	5,9	2,1	3,3	e > 0,29 * b + 21	e > 0,48 * b + 25
								0,74*(1,90*b+116)/(e-1,5)	0,87*(3,12*b+147)/(e-1,5)
			I	4,4	5,9	2,5	4,1	e ≤ 0,31 * b + 21	e ≤ 0,51 * b + 26
								5,1	5,1
								e > 0,31 * b + 21	e > 0,51 * b + 26
								0,74*(2,17*b+123)/(e-1,5)	0,87*(3,57*b+158)/(e-1,5)
					e ≤ 0,33 * b + 20	e ≤ 0,54 * b + 25			
					5,5	5,5			
					e > 0,33 * b + 20	e > 0,54 * b + 25			
					0,74*(2,45*b+130)/(e-1,5)	0,87*(4,01*b+169)/(e-1,5)			
					e ≤ 0,36 * b + 20	e ≤ 0,60 * b + 26			
					6,0	6,0			
					e > 0,36 * b + 20	e > 0,60 * b + 26			
					0,74*(2,99*b+143)/(e-1,5)	0,87*(4,90*b+191)/(e-1,5)			

Bolt factor	for F <sub>1</sub>	for F <sub>2/3</sub>	for F <sub>4/5</sub> , bolt 1	for F <sub>4/5</sub> , bolt 2
k <sub>ax</sub>	0,98	0,23	1,96 x e / (b + 25)	-
k <sub>lat</sub>	-	0,50	-	1,00

For each bolt it's needed to check:  $R_{bolt,d,lateral} \geq k_{lat} \times F_{i,d}$  ;  $R_{bolt,d,axial} \geq k_{ax} \times F_{i,d}$  ; and also the combination

**Table D31-7** *Modified characteristic capacity timber beam to timber beam – 2 Angle Brackets E5/1.5 & E5/1.5/11.22/11, Nailing pattern 3*

2 Angle Brackets per connection			Modified characteristic capacity per connection (kN)								
Nailing pattern	Number of Fasteners		Load duration	$R_{1,k} \times k_{mod}$				$R_{2/3,k} \times k_{mod}$			
	Flange A	Flange B		CNA4,0x35	CNA4,0x40	CNA4,0x50	CNA4,0x60	CNA4,0x35	CNA4,0x40	CNA4,0x50	CNA4,0x60
Nailing pattern 3	7	6	P	3,7	4,3	5,2	5,6	5,9	6,5	7,8	8,4
			L	4,3	5,0	6,0	6,5	6,9	7,6	9,1	9,8
			M	4,9	5,7	6,9	7,4	7,8	8,6	10,4	11,2
			S	5,5	6,4	7,7	8,4	8,8	9,7	11,7	12,6
			I	6,7	7,8	9,5	10,2	10,8	11,9	14,3	15,4

**Table D31-8** *Modified characteristic capacity timber beam to timber beam – 2 Angle Brackets E5/1.5 & E5/1.5/11.22/11, Nailing pattern 4*

2 Angle Brackets per connection			Modified characteristic capacity per connection (kN)								
Nailing pattern	Number of Fasteners		Load duration	$R_{1,k} \times k_{mod}$				$R_{2/3,k} \times k_{mod}$ 1)			
	Flange A	Flange B		CNA4,0x35	CNA4,0x40	CNA4,0x50	CNA4,0x60	CNA4,0x35	CNA4,0x40	CNA4,0x50	CNA4,0x60
Nailing pattern 4	7	1 x Ø10 Bolt	P	4,0	4,0	4,0	4,0	3,5	4,0	5,2	5,9
			L	4,6	4,6	4,6	4,6	4,1	4,7	6,0	6,9
			M	5,3	5,3	5,3	5,3	4,6	5,4	6,9	7,9
			S	5,9	5,9	5,9	5,9	5,2	6,0	7,7	8,9
			I	7,3	7,3	7,3	7,3	6,4	7,4	9,5	10,9

**Note:** 1) only available for a connection in a round hole, not with the version with oblong hole.  
 When there are two angle brackets, the anchor group must resist to F1 and/or F2  
 When there is one angle bracket, the anchor must resist to F1 and/or F2

**General notes to all capacity tables:**

- b, e and f are in mm.
- Wane may not occur under the angle bracket.

## Annex D32 – E5/2

### Product Name:

Product Name	Material reference acc. to clause II-1	Alternative product names
E5/2	Steel ref. 1	-
E5/2S	Steel ref. 2	-
E5/2S2	Steel ref. 3	-

### Connector Size Range:

Model no.	Dimensions [mm]				Holes flange A		Holes flange B	
	A	B	C	Thickness	Ø5	11x22	Ø5	11x22
E5/2	76,5	49,5	65	2,0	7	1	6	1 *)

\*) Optional round Hole Ø13

### Drawing:

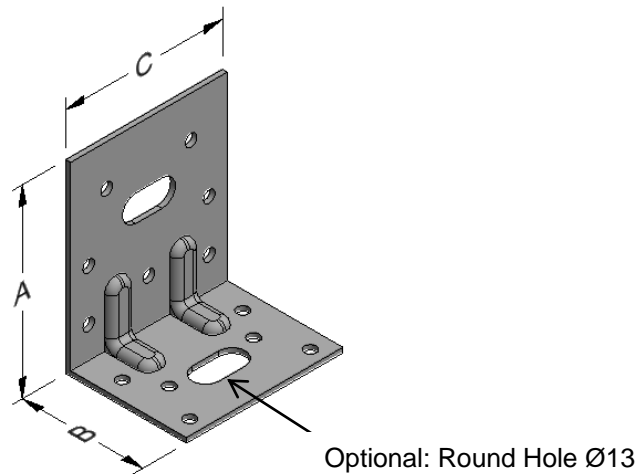

### Nailing pattern:

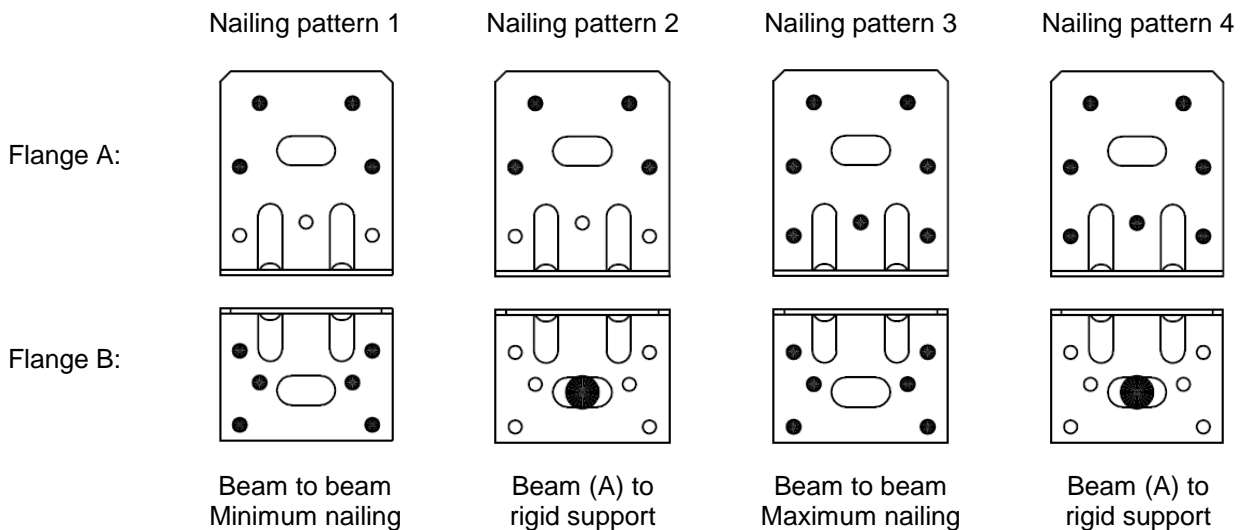



Table D32-1 Modified characteristic capacity timber beam to timber beam - 1 Angle Bracket, Nailing pattern 1

1 Angle Bracket E5/2 per connection			Modified characteristic capacity per connection (kN)								
Nailing pattern	Number of fasteners		Load duration	$R_{1,k} \times k_{mod}$		$R_{2/3,k} \times k_{mod}$		$R_{4,k} \times k_{mod}$		$R_{5,k} \times k_{mod}$	
	Flange A	Flange B		4,0x35	4,0x60	4,0x35	4,0x60	4,0x35	4,0x60	4,0x35	4,0x60
Nailing pattern 1	4	6	P	$f \leq 14$ $29 / (f + 46,5)$	$f \leq 7$ $57 / (f + 46,5)$	1,4	2,4	Min of $27,7/(e - 2)$ $23/\sqrt{(e^2 + 25)}$	Min of $27,7/(e - 2)$ $41/\sqrt{(e^2 + 38,4)}$	Min of $1,2*(b + 5)/e$ 1,2	Min of $2,4*(b + 5)/e$ 2,4
				$f > 14$ $7,1 / (f + 1)$	$f > 7$ $7,1 / (f + 1)$			4,4	4,4	For $e < 65$ $19,2 / (65 - e)$	For $e < 65$ $38,4 / (65 - e)$
				$f < 41$ $7 / (41 - e)$	$f < 41$ $7 / (41 - e)$			$65 / e$			
			L	$f \leq 11$ $33 / (f + 46,5)$	$f \leq 6$ $67 / (f + 46,5)$	1,6	2,9	Min of $27,7/(e - 2)$ $28/\sqrt{(e^2 + 25)}$	Min of $27,7/(e - 2)$ $48/\sqrt{(e^2 + 38,4)}$	Min of $1,4*(b + 5)/e$ 1,55	Min of $2,8*(b + 5)/e$ 2,35
				$f > 11$ $7,1 / (f + 1)$	$f > 6$ $7,1 / (f + 1)$			4,8	4,8	For $e < 65$ $22,4 / (65 - e)$	For $e < 65$ $44,8 / (65 - e)$
				$f < 41$ $7 / (41 - e)$	$f < 41$ $7 / (41 - e)$			$65 / e$			
			M	$f \leq 10$ $38 / (f + 46,5)$	$f \leq 5$ $76 / (f + 46,5)$	1,8	3,3	Min of $27,7/(e - 2)$ $32/\sqrt{(e^2 + 25)}$	Min of $27,7/(e - 2)$ $55/\sqrt{(e^2 + 38,4)}$	Min of $1,6*(b + 5)/e$ 1,6	Min of $3,2*(b + 5)/e$ 2,5
				$f > 10$ $7,1 / (f + 1)$	$f > 5$ $7,1 / (f + 1)$			5,2	5,2	For $e < 65$ $25,6 / (65 - e)$	For $e < 41$ min of:
				$f < 41$ $7 / (41 - e)$	$f < 41$ $7 / (41 - e)$			$65 / e$			
			S	$f \leq 8$ $43 / (f + 46,5)$	$f \leq 4$ $86 / (f + 46,5)$	2,1	3,7	Min of $27,7/(e - 2)$ $36/\sqrt{(e^2 + 25)}$	Min of $27,7/(e - 2)$ $61/\sqrt{(e^2 + 38,4)}$	Min of $2,42*(b + 5)/e$ 1,7	Min of $3,6*(b + 5)/e$ 2,7
				$f > 8$ $7,1 / (f + 1)$	$f > 4$ $7,1 / (f + 1)$			5,5	5,5	For $e < 65$ $28,8 / (65 - e)$	For $e < 41$ min of:
				$f < 41$ $7 / (41 - e)$	$f < 41$ $7 / (41 - e)$			$65 / e$			
			I	$f \leq 6$ $52 / (f + 46,5)$	$f \leq 3$ $105 / (f + 46,5)$	2,6	4,5	Min of $27,7/(e - 2)$ $44/\sqrt{(e^2 + 25)}$	Min of $27,7/(e - 2)$ $74/\sqrt{(e^2 + 38,4)}$	Min of $2,95*(b + 5)/e$ 1,9	Min of $3,2*(b + 5)/e$ 2,9
				$f > 6$ $7,1 / (f + 1)$	$f > 3$ $7,1 / (f + 1)$			6	6	For $e < 65$ $35,2 / (65 - e)$	For $e < 41$ min of:
				$f < 41$ $7 / (41 - e)$	$f < 41$ $7 / (41 - e)$			$65 / e$			

Note: For  $R_{4,k}$  if the purlin is prevented from rotation, consider the value given for two brackets for  $e=0$ .

**Table D32-2** Modified characteristic capacity timber beam to timber beam – 2 Angle Brackets, Nailing pattern 1

2 Angle Brackets E5/2 per connection			Modified characteristic capacity per connection (kN)						
Nailing pattern	Number of fasteners		Load duration	$R_{1,k} \times k_{mod}$		$R_{2/3,k} \times k_{mod}$		$R_{4/5,k} \times k_{mod}$	
	Flange A	Flange B		4,0x35	4,0x60	4,0x35	4,0x60	4,0x35	4,0x60
Nailing pattern 1	4	6	P	2,5	5,0	2,8	4,9	$e \leq 0,26 * b + 18$	$e \leq 0,43 * b + 20$
								4,8	4,8
			L	3,0	5,8	3,2	5,8	$e > 0,26 * b + 18$	$e > 0,43 * b + 20$
								$0,74*(1,70*b+100)/(e-2)$	$0,87*(2,89*b+118)/(e-2)$
			M	3,3	6,7	3,7	6,5	$e \leq 0,27 * b + 17$	$e \leq 0,46 * b + 19$
								5,4	5,4
			S	3,7	7,5	4,2	7,4	$e > 0,27 * b + 17$	$e > 0,46 * b + 19$
								$0,74*(1,98*b+108)/(e-2)$	$0,87*(3,37*b+125)/(e-2)$
			I	4,6	8,8	5,2	9,1	$e \leq 0,29 * b + 17$	$e \leq 0,50 * b + 19$
								5,7	5,7
			S	3,7	7,5	4,2	7,4	$e > 0,29 * b + 17$	$e > 0,50 * b + 19$
								$0,74*(2,26*b+109)/(e-2)$	$0,87*(3,85*b+133)/(e-2)$
I	4,6	8,8	5,2	9,1	$e \leq 0,31 * b + 17$	$e \leq 0,53 * b + 19$			
					7,1	7,1			
S	3,7	7,5	4,2	7,4	$e > 0,31 * b + 17$	$e > 0,53 * b + 19$			
					$0,74*(2,54*b+113)/(e-2)$	$0,87*(4,33*b+140)/(e-2)$			
I	4,6	8,8	5,2	9,1	$e \leq 0,34 * b + 16$	$e \leq 0,56 * b + 19$			
					6,7	6,7			
S	3,7	7,5	4,2	7,4	$e > 0,34 * b + 16$	$e > 0,56 * b + 19$			
					$0,74*(3,11*b+122)/(e-2)$	$0,87*(5,07*b+151)/(e-2)$			

**Table D32-3 Modified characteristic capacity timber beam to rigid support – 1 Angle Bracket, Nailing pattern 2**

1 Angle Bracket E5/2 per connection			Modified characteristic capacity per connection (kN)							
Nailing pattern	Number of fasteners		Load duration	$R_{1,k} \times k_{mod}$		$R_{2/3,k} \times k_{mod}$		$R_{4,k} \times k_{mod}$		
	Flange A	Flange B		4,0x35	4,0x60	4,0x35	4,0x60	4,0x35	4,0x60	
Nailing pattern 2	4	1 x Ø10 Bolt	P	Min of 13,8 / ( f+ 24) 7,2 / f		0,6	1,1	Min of 55,4 / e 14,2 / (e -26) 12,9		
			L			0,8	1,3			
			M			0,9	1,5			
			S			1,1	1,7			
			I			1,2	2,1			

**Note:** For  $R_{4,k}$  if the purlin is prevented from rotation, consider the value given for two brackets for  $e=0$ .

Bolt factor	for $F_1$	for $F_{2/3}$	for $F_4$
$k_{ax}$	$(f + 38) / 8$	0,09	$e / 8$
$k_{lat}$	-	1,00	1,00

For each bolt it's needed to check:  $R_{bolt,d,lateral} \geq k_{lat} \times F_{i,d}$  ;  $R_{bolt,d,axial} \geq k_{ax} \times F_{i,d}$  ; and also the combination

**Table D32-4 Modified characteristic capacity timber beam to rigid support – 2 Angle Brackets, Nailing pattern 2**

2 Angle Brackets E5/2 per connection			Modified characteristic capacity per connection (kN)								
Nailing pattern	Number of fasteners		Load duration	$R_{1,k} \times k_{mod}$		$R_{2/3,k} \times k_{mod}$		$R_{4/5,k} \times k_{mod}$			
	Flange A	Flange B		4,0x35	4,0x60	4,0x35	4,0x60	4,0x35	4,0x60		
Nailing pattern 2	4	1 x Bolt Ø10	P	2,4	4,5	1,3	2,2	$e \leq 0,22 * b + 23$	$e \leq 0,35 * b + 26$		
								5,3	5,3		
										$e > 0,22 * b + 23$	$e > 0,35 * b + 26$
										$0,74*(1,59*b+145)/(e-2)$	$0,87*(2,61*b+170)/(e-2)$
			L	2,7	5,3	1,5	2,7			$e \leq 0,23 * b + 22$	$e \leq 0,38 * b + 25$
										6,0	6,0
										$e > 0,23 * b + 22$	$e > 0,38 * b + 25$
										$0,74*(1,85*b+151)/(e-2)$	$0,87*(3,05*b+181)/(e-2)$
			M	3,1	6,1	1,7	3,1			$e \leq 0,25 * b + 21$	$e \leq 0,40 * b + 25$
										6,4	6,4
										$e > 0,25 * b + 21$	$e > 0,40 * b + 25$
										$0,74*(2,12*b+158)/(e-2)$	$0,87*(3,48*b+192)/(e-2)$
S	3,5	6,8	2,0	3,4			$e \leq 0,26 * b + 21$	$e \leq 0,43 * b + 25$			
							6,8	6,8			
							$e > 0,26 * b + 21$	$e > 0,43 * b + 25$			
							$0,74*(2,38*b+164)/(e-2)$	$0,87*(3,92*b+203)/(e-2)$			
I	4,3	8,3	2,5	4,1			$e \leq 0,29 * b + 21$	$e \leq 0,47 * b + 25$			
							7,5	7,5			
							$e > 0,29 * b + 21$	$e > 0,47 * b + 25$			
							$0,74*(2,91*b+178)/(e-2)$	$0,87*(4,79*b+225)/(e-2)$			

Bolt factor	for $F_1$	for $F_{2/3}$	for $F_{4/5}$ , bolt 1	for $F_{4/5}$ , bolt 2
$k_{ax}$	1,00	0,05	$1,99 \times e / (b + 25)$	-
$k_{lat}$	-	0,50	-	1,00

For each bolt it's needed to check:  $R_{bolt,d,lateral} \geq k_{lat} \times F_{i,d}$  ;  $R_{bolt,d,axial} \geq k_{ax} \times F_{i,d}$  ; and also the combination

**Table D32-5** Modified characteristic capacity timber beam to timber beam – 2 Angle Brackets, Nailing pattern 3

2 Angle Brackets E5/2 per connection			Modified characteristic capacity per connection (kN)								
Nailing pattern	Number of Fasteners		Load duration	$R_{1,k} \times k_{mod}$				$R_{2/3,k} \times k_{mod}$			
	Flange A	Flange B		CNA4,0x35	CNA4,0x40	CNA4,0x50	CNA4,0x60	CNA4,0x35	CNA4,0x40	CNA4,0x50	CNA4,0x60
Nailing pattern 3	7	6	P	3,7	4,3	5,2	5,9	5,9	6,4	7,8	8,3
			L	4,3	5,0	6,0	6,9	6,9	7,5	9,1	9,7
			M	4,9	5,7	6,9	7,8	7,8	8,6	10,4	11,0
			S	5,5	6,4	7,7	8,8	8,8	9,6	11,7	12,4
			I	6,7	7,8	9,5	10,8	10,8	11,8	14,3	15,2

**Table D32-6** Modified characteristic capacity timber beam to timber beam – 2 Angle Brackets, Nailing pattern 4

2 Angle Brackets E5/2 per connection			Modified characteristic capacity per connection (kN)								
Nailing pattern	Number of Fasteners		Load duration	$R_{1,k} \times k_{mod}$				$R_{2/3,k} \times k_{mod} 1)$			
	Flange A	Flange B		CNA4,0x35	CNA4,0x40	CNA4,0x50	CNA4,0x60	CNA4,0x35	CNA4,0x40	CNA4,0x50	CNA4,0x60
Nailing pattern 4	7	1 x Ø10 Bolt	P	5,0	5,0	5,0	5,0	3,6	4,1	5,3	6,1
			L	5,9	5,9	5,9	5,9	4,2	4,8	6,2	7,1
			M	6,7	6,7	6,7	6,7	4,8	5,5	7,0	8,1
			S	7,6	7,6	7,6	7,6	5,4	6,2	7,9	9,1
			I	9,2	9,2	9,2	9,2	6,6	7,6	9,7	11,1

**Note:** 1) only available for a connection in a round hole, not with the version with oblong hole.

When there are two angle brackets, the anchor group must resist to F1 and/or F2

When there is one angle bracket, the anchor must resist to F1 and/or F2

**General notes to all capacity tables:**

- b, e and f are in mm.
- Wane may not occur under the angle bracket.

## Annex D33 – AT1

### Product Name:

Product Name	Material reference acc. to clause II-1	Alternative product names
AT1	Steel ref. 1	-
AT1S	Steel ref. 2	-
AT1S2	Steel ref. 3	-

### Connector Size Range:

Model no.	Dimensions [mm]				Holes flange A		Holes flange B		
	A	B	C	Thickness	Ø5	Ø10	Ø5	Ø10	10x22
AT1	77,5	49	55	1,5	7	1	4	1	1

### Drawing:

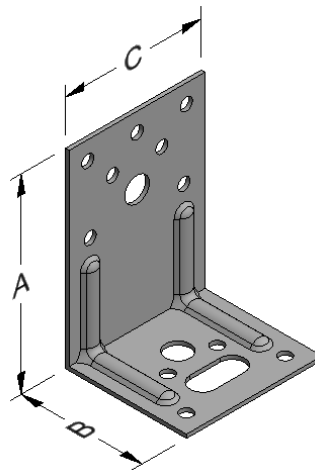

### Nailing pattern:

Nailing pattern 1

Nailing pattern 2

Nailing pattern 3

Flange A:

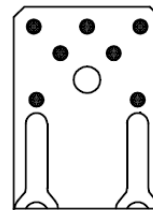
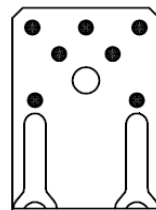
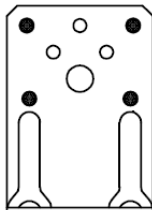

Flange B:

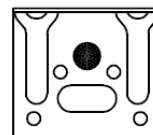
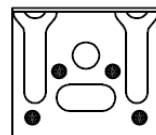
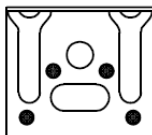

Beam to beam  
Minimum nailing

Beam to beam  
Maximum nailing

Beam (A) to  
rigid support

**Table D33-1 Modified characteristic capacity timber beam to timber beam – 1 Angle Bracket, Nailing pattern 1**

1 Angle Bracket AT1 per connection			Modified characteristic capacity per connection (kN)										
Nailing pattern	Number of fasteners		Load duration	$R_{1,k} \times k_{mod}$		$R_{2/3,k} \times k_{mod}$		$R_{4,k} \times k_{mod}$		$R_{5,k} \times k_{mod}$			
	Flange A	Flange B		4,0x35	4,0x60	4,0x35	4,0x60	4,0x35	4,0x60	4,0x35	4,0x60		
Nailing pattern 1	4	4	P	$f \leq 15$ $15 / (f + 43,5)$	$f \leq 7$ $32 / (f + 43,5)$	1,2	2,1	Min of $17,7 / (e - 1,5)$ $15 / \sqrt{(e^2 + 24)}$	Min of $17,7 / (e - 1,5)$ $27 / \sqrt{(e^2 + 37,2)}$	Min of $0,7 * (b + 13) / e$ 1	Min of $1,4 * (b + 13) / e$ 1,5		
				$f > 15$ $4,3 / (f + 1)$	$f > 7$ $4,3 / (f + 1)$			3,5 $5,5 / (e - 36)$	3,5 $5,5 / (e - 36)$	For $e < 42,5$ $21,7 / (70 - e)$ 40 / e $5,5 / (43 - e)$	For $e < 42,5$ $43,6 / (70 - e)$ 40 / e $5,5 / (43 - e)$		
				$f \leq 12$ $18 / (f + 43,5)$	$f \leq 6$ $37 / (f + 43,5)$			1,3	2,3	Min of $17,7 / (e - 1,5)$ $18 / \sqrt{(e^2 + 24)}$	Min of $17,7 / (e - 1,5)$ $32 / \sqrt{(e^2 + 37,2)}$	Min of $0,8 * (b + 13) / e$ 1,1	Min of $1,63 * (b + 13) / e$ 1,7
				$f > 12$ $4,3 / (f + 1)$	$f > 6$ $4,3 / (f + 1)$					3,8 $5,5 / (e - 36)$	3,8 $5,5 / (e - 36)$	For $e < 42,5$ $25,4 / (70 - e)$ 40 / e $5,5 / (43 - e)$	For $e < 42,5$ $51 / (70 - e)$ 40 / e $5,5 / (43 - e)$
			M	$f \leq 10$ $21 / (f + 43,5)$	$f \leq 5$ $42 / (f + 43,5)$	1,5	2,7	Min of $17,7 / (e - 1,5)$ $21 / \sqrt{(e^2 + 24)}$	Min of $17,7 / (e - 1,5)$ $36 / \sqrt{(e^2 + 37,2)}$	Min of $0,93 * (b + 13) / e$ 1,2	Min of $1,9 * (b + 13) / e$ 1,7		
				$f > 10$ $4,3 / (f + 1)$	$f > 5$ $4,3 / (f + 1)$			4,1 $5,5 / (e - 36)$	4,1 $5,5 / (e - 36)$	For $e < 42,5$ $29 / (70 - e)$ 40 / e $5,5 / (43 - e)$	For $e < 42,5$ 40 / e $5,5 / (43 - e)$		
			S	$f \leq 9$ $23 / (f + 43,5)$	$f \leq 4$ $48 / (f + 43,5)$	1,8	3,1	Min of $17,7 / (e - 1,5)$ $23 / \sqrt{(e^2 + 24)}$	Min of $17,7 / (e - 1,5)$ $41 / \sqrt{(e^2 + 37,2)}$	Min of $1,05 * (b + 13) / e$ 1,3	Min of $2,1 * (b + 13) / e$ 1,8		
				$f > 9$ $4,3 / (f + 1)$	$f > 4$ $4,3 / (f + 1)$			4,3 $5,5 / (e - 36)$	4,3 $5,5 / (e - 36)$	For $e < 42,5$ $32,6 / (70 - e)$ 40 / e $5,5 / (43 - e)$	For $e < 42,5$ 40 / e $5,5 / (43 - e)$		
			I	$f \leq 7$ $29 / (f + 43,5)$	$f \leq 3$ $58 / (f + 43,5)$	2,1	3,7	Min of $17,7 / (e - 1,5)$ $29 / \sqrt{(e^2 + 24)}$	Min of $17,7 / (e - 1,5)$ $50 / \sqrt{(e^2 + 37,2)}$	Min of $1,28 * (b + 13) / e$ 1,4	Min of $2,4 * (b + 13) / e$ 1,9		
				$f > 7$ $4,3 / (f + 1)$	$f > 3$ $4,3 / (f + 1)$			4,7 $5,5 / (e - 36)$	4,7 $5,5 / (e - 36)$	For $e < 42,5$ 40 / (70 - e) 40 / e $5,5 / (43 - e)$	For $e < 42,5$ 40 / e $5,5 / (43 - e)$		

**Note:** For  $R_{4,k}$  if the purlin is prevented from rotation, consider the value given for two brackets for  $e=0$ .

Table D33-2 Modified characteristic capacity timber beam to timber beam – 1 Angle Bracket, Nailing pattern 2

1 Angle Bracket AT1 per connection			Modified characteristic capacity per connection (kN)											
Nailing pattern	Number of fasteners		Load duration	$R_{1,k} \times k_{mod}$		$R_{2/3,k} \times k_{mod}$		$R_{4,k} \times k_{mod}$		$R_{5,k} \times k_{mod}$				
	Flange A	Flange B		4,0x35	4,0x60	4,0x35	4,0x60	4,0x35	4,0x60	4,0x35	4,0x60			
Nailing pattern 2	7	4	P	$f \leq 15$ $15 / (f + 43,5)$	$f \leq 7$ $32 / (f + 43,5)$	1,2	2,2	Min of $17,7/(e - 1,5)$ $15/\sqrt{(e^2 + 24)}$	Min of $17,7/(e - 1,5)$ $27/\sqrt{(e^2 + 37,2)}$	Min of $0,7*(b + 13)/e$ 1 For $e < 42,5$ $21,7 / (70 - e)$ $40 / e$ $5,5 / (43 - e)$	Min of $1,4*(b + 13)/e$ 1,5 For $e < 42,5$ $40 / e$ $5,5 / (43 - e)$			
				$f > 15$ $4,3 / (f + 1)$	$f > 7$ $4,3 / (f + 1)$									
				L	$f \leq 12$ $18 / (f + 43,5)$			$f \leq 6$ $37 / (f + 43,5)$	1,4	2,5	Min of $17,7/(e - 1,5)$ $18/\sqrt{(e^2 + 24)}$	Min of $17,7/(e - 1,5)$ $32/\sqrt{(e^2 + 37,2)}$	Min of $0,8*(b + 13)/e$ 1,1 For $e < 42,5$ $25,4 / (70 - e)$ $40 / e$ $5,5 / (43 - e)$	Min of $1,63*(b + 13)/e$ 1,7 For $e < 42,5$ $40 / e$ $5,5 / (43 - e)$
					$f > 12$ $4,3 / (f + 1)$			$f > 6$ $4,3 / (f + 1)$						
			M	$f \leq 10$ $38 / (f + 46,5)$	$f \leq 5$ $42 / (f + 43,5)$	1,6	2,8	Min of $17,7/(e - 1,5)$ $21/\sqrt{(e^2 + 24)}$	Min of $17,7/(e - 1,5)$ $36/\sqrt{(e^2 + 37,2)}$	Min of $0,93*(b + 13)/e$ 1,2 For $e < 42,5$ $29 / (70 - e)$ $40 / e$ $5,5 / (43 - e)$	Min of $1,9*(b + 13)/e$ 1,7 For $e < 42,5$ $40 / e$ $5,5 / (43 - e)$			
				$f > 10$ $4,3 / (f + 1)$	$f > 5$ $4,3 / (f + 1)$									
			S	$f \leq 9$ $23 / (f + 43,5)$	$f \leq 4$ $48 / (f + 43,5)$	1,8	3,1	Min of $17,7/(e - 1,5)$ $23/\sqrt{(e^2 + 24)}$	Min of $17,7/(e - 1,5)$ $41/\sqrt{(e^2 + 37,2)}$	Min of $1,05*(b + 13)/e$ 1,3 For $e < 42,5$ $40 / e$ $5,5 / (43 - e)$	Min of $2,1*(b + 13)/e$ 1,8 For $e < 42,5$ $40 / e$ $5,5 / (43 - e)$			
				$f > 9$ $4,3 / (f + 1)$	$f > 4$ $4,3 / (f + 1)$									
			I	$f \leq 7$ $29 / (f + 43,5)$	$f \leq 3$ $58 / (f + 43,5)$	2,2	3,9	Min of $17,7/(e - 1,5)$ $29/\sqrt{(e^2 + 24)}$	Min of $17,7/(e - 1,5)$ $50/\sqrt{(e^2 + 37,2)}$	Min of $1,28*(b + 13)/e$ 1,4 For $e < 42,5$ $40 / e$ $5,5 / (43 - e)$	Min of $2,4*(b + 13)/e$ 1,9 For $e < 42,5$ $40 / e$ $5,5 / (43 - e)$			
				$f > 7$ $4,3 / (f + 1)$	$f > 3$ $4,3 / (f + 1)$									

Note: For  $R_{4,k}$  if the purlin is prevented from rotation, consider the value given for two brackets for  $e=0$ .



Table D33-3 Modified characteristic capacity timber beam to timber beam – 2 Angle Brackets, Nailing pattern 1

2 Angle Brackets AT1 per connection			Modified characteristic capacity per connection (kN)							
Nailing pattern	Number of fasteners		Load duration	$R_{1,k} \times k_{mod}$		$R_{2/3,k} \times k_{mod}$		$R_{4/5,k} \times k_{mod}$		
	Flange A	Flange B		4,0x35	4,0x60	4,0x35	4,0x60	4,0x35	4,0x60	
Nailing pattern 1	4	4	P	1,5	2,9	2,3	4,0	$e \leq 0,23 \cdot b + 21$	$e \leq 0,34 \cdot b + 21$	
								3,2	3,7	
			L	1,7	3,5	2,7	4,8	$e > 0,23 \cdot b + 21$	$e > 0,34 \cdot b + 21$	
								$0,74 \cdot (b+77)/(e-1,5)$	$0,87 \cdot (1,7 \cdot b+93)/(e-1,5)$	
			M	2,0	3,9	3,1	5,4	$e \leq 0,23 \cdot b + 18$	$e \leq 0,39 \cdot b + 21$	
								4,3	4,3	
			S	2,2	4,4	3,5	6,1	$e > 0,23 \cdot b + 18$	$e > 0,39 \cdot b + 21$	
								$0,74 \cdot (1,33 \cdot b+85)/(e-1,5)$	$0,87 \cdot (2,27 \cdot b+106)/(e-1,5)$	
			I	2,7	5,0	4,3	7,5	$e \leq 0,23 \cdot b + 17$	$e \leq 0,41 \cdot b + 21$	
								4,6	4,6	
			I	2,7	5,0	4,3	7,5	$e > 0,23 \cdot b + 17$	$e > 0,41 \cdot b + 21$	
								$0,74 \cdot (1,5 \cdot b+88)/(e-1,5)$	$0,87 \cdot (2,55 \cdot b+113)/(e-1,5)$	
I	2,7	5,0	4,3	7,5	$e \leq 0,27 \cdot b + 17$	$e \leq 0,43 \cdot b + 21$				
					5	5				
I	2,7	5,0	4,3	7,5	$e > 0,27 \cdot b + 17$	$e > 0,43 \cdot b + 21$				
					$0,74 \cdot (1,83 \cdot b+96)/(e-1,5)$	$0,87 \cdot (2,92 \cdot b+121)/(e-1,5)$				

Table D33-4 Modified characteristic capacity timber beam to timber beam – 2 Angle Brackets, Nailing pattern 2

2 Angle Brackets AT1 per connection			Modified characteristic capacity per connection (kN)										
Nailing pattern	Number of fasteners		Load duration	$R_{1,k} \times k_{mod}$				$R_{2/3,k} \times k_{mod}$				$R_{4/5,k} \times k_{mod}$	
	Flange A	Flange B		4,0x35	4,0x40	4,0x50	4,0x60	4,0x35	4,0x40	4,0x50	4,0x60	4,0x35	4,0x60
Nailing pattern 2	4	6	P	3,4	4,1	4,8	4,8	5,6	6,1	7,4	7,9	$e \leq 0,23 * b + 21$ 3,2	$e \leq 0,34 * b + 21$ 3,7
												$e > 0,23 * b + 21$ $0,74*(b+77)/(e-1,5)$	$e > 0,34 * b + 21$ $0,87*(1,7*b+93)/(e-1,5)$
			L	3,4	4,1	4,8	4,8	5,6	6,1	7,4	7,9	$e \leq 0,23 * b + 19$ 3,7	$e \leq 0,36 * b + 21$ 4,0
												$e > 0,23 * b + 19$ $0,74*(1,16*b+81)/(e-1,5)$	$e > 0,36 * b + 21$ $0,87*(1,98*b+100)/(e-1,5)$
			M	3,4	4,1	4,8	4,8	5,6	6,1	7,4	7,9	$e \leq 0,23 * b + 18$ 4,3	$e \leq 0,39 * b + 21$ 4,3
												$e > 0,23 * b + 18$ $0,74*(1,33*b+85)/(e-1,5)$	$e > 0,39 * b + 21$ $0,87*(2,27*b+106)/(e-1,5)$
			S	3,4	4,1	4,8	4,8	5,6	6,1	7,4	7,9	$e \leq 0,24 * b + 17$ 4,6	$e \leq 0,41 * b + 21$ 4,6
												$e > 0,24 * b + 17$ $0,74*(1,5*b+88)/(e-1,5)$	$e > 0,41 * b + 21$ $0,87*(2,55*b+113)/(e-1,5)$
			I	3,4	4,1	4,8	4,8	5,6	6,1	7,4	7,9	$e \leq 0,27 * b + 17$ 5,0	$e \leq 0,43 * b + 21$ 5,0
												$e > 0,27 * b + 17$ $0,74*(1,83*b+96)/(e-1,5)$	$e > 0,43 * b + 21$ $0,87*(2,92*b+121)/(e-1,5)$

*Table D33-5 Modified characteristic capacity timber beam to rigid support – 1 Angle Bracket, Nailing pattern 3*

1 Angle Bracket AT1 per connection				Modified characteristic capacity per connection (kN)					
Nailing pattern	Number of Fasteners		Load duration	$R_{1,k} \times k_{mod}$		$R_{2/3,k} \times k_{mod}$		$R_{4,k} \times k_{mod}$	
	Flange A	Flange B		4,0x35	4,0x60	4,0x35	4,0x60	4,0x35	4,0x60
	Nailing pattern 3	7		1 x Ø8 Bolt	P	Min of $28 / (f + 13)$ $4,3 / f$		1,0	1,9
			L	1,2	2,2				
			M	1,3	2,5				
			S	1,5	2,9				
			I	1,8	3,5				

Note: For  $R_{4,k}$  if the purlin is prevented from rotation, consider the value given for two brackets for  $e=0$ .

Bolt factor	for $F_1$	for $F_{2/3}$	for $F_4$
$k_{ax}$	$(f + 23) / 6$	1,31	$e / 6$
$k_{lat}$	-	1,00	1,00

For each bolt it's needed to check:  $R_{bolt,d,lateral} \geq k_{lat} \times F_{i,d}$ ;  $R_{bolt,d,axial} \geq k_{ax} \times F_{i,d}$ ; and also the combination

**Table D33-6 Modified characteristic capacity timber beam to rigid support – 2 Angle Brackets, Nailing pattern 3**

2 Angle Brackets AT1 per connection			Modified characteristic capacity per connection (kN)												
Nailing pattern	Number of fasteners		Load duration	$R_{1,k} \times k_{mod}$				$R_{2/3,k} \times k_{mod}$				$R_{4/5,k} \times k_{mod}$			
	Flange A	Flange B		4,0x35	4,0x40	4,0x50	4,0x60	4,0x35	4,0x40	4,0x50	4,0x60	4,0x35	4,0x60		
Nailing pattern 3	7	1 x Ø8 Bolt	P	7,5	7,5	7,5	7,5	5,0	5,6	6,9	7,5	$e \leq 0,68 * b + 28$	$e \leq 1,08 * b + 34$		
												4,3	4,3		
			L	7,5	7,5	7,5	7,5	5,0	5,6	6,9	7,5	$e \leq 0,73 * b + 28$	$e \leq 1,16 * b + 35$		
												4,6	4,6		
			M	7,5	7,5	7,5	7,5	5,0	5,6	6,9	7,5	$e \leq 0,78 * b + 28$	$e \leq 1,24 * b + 35$		
												4,9	4,9		
			S	7,5	7,5	7,5	7,5	5,0	5,6	6,9	7,5	$e \leq 0,83 * b + 28$	$e \leq 1,32 * b + 36$		
												5,2	5,2		
			I	7,5	7,5	7,5	7,5	5,0	5,6	6,9	7,5	$e \leq 0,92 * b + 28$	$e \leq 1,46 * b + 37$		
												5,8	5,8		
			$e > 0,68 * b + 28$ $0,74 * (3,93 * b + 145) / (e - 1,5)$												$e > 1,08 * b + 34$ $0,87 * (6,24 * b + 182) / (e - 1,5)$
			$e > 0,73 * b + 28$ $0,74 * (4,58 * b + 154) / (e - 1,5)$												$e > 1,16 * b + 35$ $0,87 * (7,28 * b + 199) / (e - 1,5)$
$e > 0,78 * b + 28$ $0,74 * (5,23 * b + 165) / (e - 1,5)$												$e > 1,24 * b + 35$ $0,87 * (8,32 * b + 217) / (e - 1,5)$			
$e > 0,83 * b + 28$ $0,74 * (5,89 * b + 176) / (e - 1,5)$												$e > 1,32 * b + 36$ $0,87 * (9,36 * b + 235) / (e - 1,5)$			
$e > 0,92 * b + 28$ $0,74 * (7,20 * b + 198) / (e - 1,5)$												$e > 1,46 * b + 37$ $0,87 * (11,44 * b + 270) / (e - 1,5)$			

Bolt factor	for $F_1$	for $F_{2/3}$	for $F_{4/5}$ , bolt 1	for $F_{4/5}$ , bolt 2
$k_{ax}$	1,17	0,65	$2,35 \times e / (b + 17)$	-
$k_{lat}$	-	0,50	-	1,00

General notes to all capacity tables:

- b, e and f are in mm.
- Wane may not occur under the angle bracket.

## Annex D34 – E4/2.5

### Product Name:

Product Name	Material reference acc. to clause II-1	Alternative product names
E4/2.5	Steel ref. 1	-
E4/2.5S	Steel ref. 2	-
E4/2.5S2	Steel ref. 3	-

### Connector Size Range:

Model no.	Dimensions [mm]				Holes flange A		Holes flange B	
	A	B	C	Thickness	Ø5	Ø13	Ø5	12x20
E4/2.5	102,5	62,5	75	2,5	8	1	6	1 *)

\*) Optional round Hole Ø12

### Drawing:

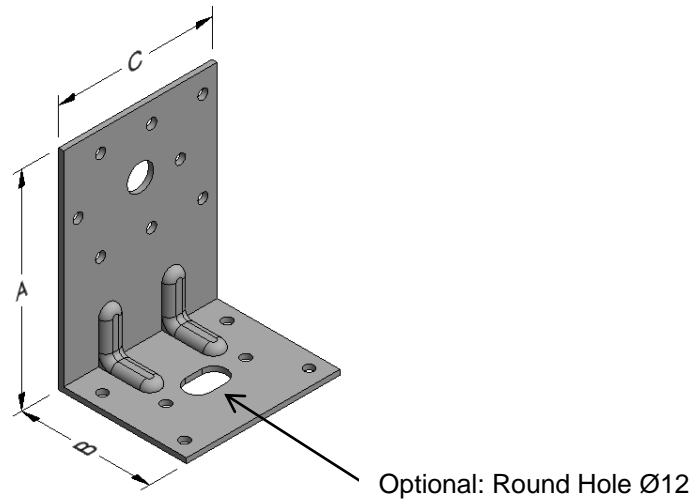

### Nailing pattern:

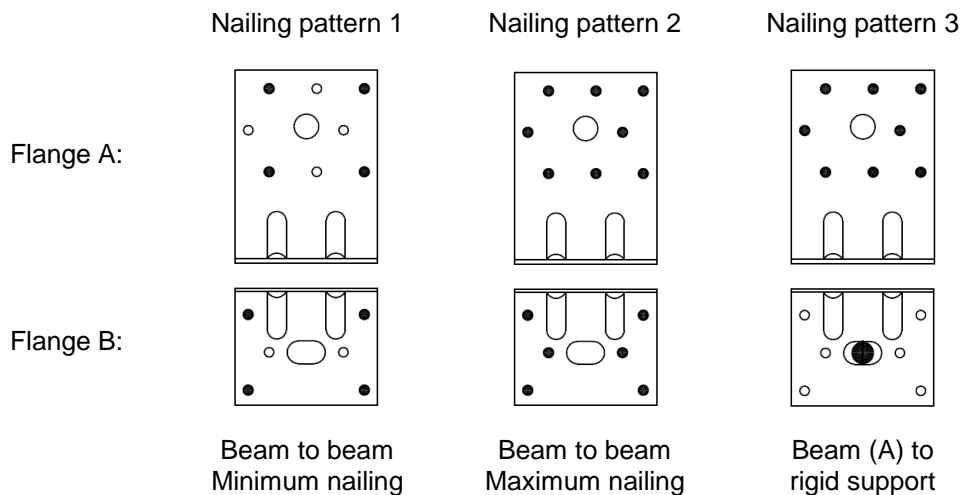

Table D34-1 Modified characteristic capacity timber beam to timber beam – 1 Angle Bracket, Nailing pattern 1

1 Angle Bracket E4/2.5 per connection			Modified characteristic capacity per connection (kN)				
Nailing pattern	Number of fasteners		Load duration	$R_{1,k} \times k_{mod}$		$R_{2/3,k} \times k_{mod}$	
	Flange A	Flange B		4,0x35	4,0x60	4,0x35	4,0x60
Nailing pattern 1	4	4	P	$f \leq 92,4$ $32 / (f + 56,6)$	$f \leq 31,1$ $65 / (f + 56,6)$	1,2	2,1
				$f > 92,4$ $20,5 / (f + 1)$	$f > 31,1$ $20,5 / (f + 1)$		
			L	$f \leq 63,4$ $37 / (f + 56,6)$	$f \leq 24,4$ $75 / (f + 56,6)$	1,5	2,5
				$f > 63,4$ $20,5 / (f + 1)$	$f > 24,4$ $20,5 / (f + 1)$		
			M	$f \leq 48,1$ $43 / (f + 56,6)$	$f \leq 19,9$ $87 / (f + 56,6)$	1,7	3,0
				$f > 48,1$ $20,5 / (f + 1)$	$f > 19,9$ $20,5 / (f + 1)$		
			S	$f \leq 38,7$ $49 / (f + 56,6)$	$f \leq 16,8$ $97 / (f + 56,6)$	1,9	3,3
				$f > 38,7$ $20,5 / (f + 1)$	$f > 16,8$ $20,5 / (f + 1)$		
			I	$f \leq 27,6$ $60 / (f + 56,6)$	$f \leq 12,7$ $120 / (f + 56,6)$	2,3	4,0
				$f > 27,6$ $20,5 / (f + 1)$	$f > 12,7$ $20,5 / (f + 1)$		

Table D34-2 Modified characteristic capacity timber beam to timber beam – 1 Angle Bracket, Nailing pattern 2

1 Angle Bracket E4/2.5 per connection			Modified characteristic capacity per connection (kN)				
Nailing pattern	Number of fasteners		Load duration	$R_{1,k} \times k_{mod}$		$R_{2/3,k} \times k_{mod}$	
	Flange A	Flange B		4,0x35	4,0x60	4,0x35	4,0x60
Nailing pattern 2	8	6	P	$f \leq 65,9$ $37 / (f + 56,6)$	$f \leq 25$ $75 / (f + 56,6)$	1,3	2,6
				$f > 65,9$ $20,5 / (f + 1)$	$f > 25$ $20,5 / (f + 1)$		
			L	$f \leq 47,8$ $43 / (f + 56,6)$	$f \leq 19,8$ $87 / (f + 56,6)$	1,5	3,0
				$f > 47,8$ $20,5 / (f + 1)$	$f > 19,8$ $20,5 / (f + 1)$		
			M	$f \leq 37,4$ $50 / (f + 56,6)$	$f \leq 16,3$ $99 / (f + 56,6)$	1,7	3,5
				$f > 37,4$ $20,5 / (f + 1)$	$f > 16,3$ $20,5 / (f + 1)$		
			S	$f \leq 30,6$ $56 / (f + 56,6)$	$f \leq 13,9$ $112 / (f + 56,6)$	2,1	4,0
				$f > 30,6$ $20,5 / (f + 1)$	$f > 13,9$ $20,5 / (f + 1)$		
I	$f \leq 22,3$ $68 / (f + 56,6)$	$f \leq 10,5$ $136 / (f + 56,6)$	2,5	4,8			
	$f > 22,3$ $20,5 / (f + 1)$	$f > 10,5$ $20,5 / (f + 1)$					

**Table D34-3 Modified characteristic capacity timber beam to timber beam – 2 Angle Brackets, Nailing pattern 2**

2 Angle Brackets E4/2.5 per connection			Modified characteristic capacity per connection (kN)								
Nailing pattern	Number of Fasteners		Load duration	$R_{1,k} \times k_{mod}$				$R_{2/3,k} \times k_{mod}$			
	Flange A	Flange B		CNA4,0x35	CNA4,0x40	CNA4,0x50	CNA4,0x60	CNA4,0x35	CNA4,0x40	CNA4,0x50	CNA4,0x60
Nailing pattern 2	8	6	P	3,3	3,8	4,3	4,6	4,6	5,0	6,1	6,4
			L	3,9	4,4	5,0	5,3	5,3	5,8	7,1	7,5
			M	4,4	5,0	5,8	6,1	6,1	6,6	8,1	8,6
			S	5,0	5,7	6,5	6,8	6,8	7,5	9,1	9,6
			I	6,1	6,9	7,9	8,4	8,4	9,1	11,1	11,8

**Table D34-4 Modified characteristic capacity timber beam to rigid support – 1 Angle Bracket, Nailing pattern 3**

1 Angle Bracket E4/2.5 per connection			Modified characteristic capacity per connection (kN)				
Nailing pattern	Number of fasteners		Load duration	$R_{1,k} \times k_{mod}$		$R_{2/3,k} \times k_{mod}$ 1)	
	Flange A	Flange B		4,0x35	4,0x60	4,0x35	4,0x60
Nailing pattern 3	7	1 x Ø10 Bolt	P	Min of 15,4 / (f+13) 20,5 / f		0,6	1,2
			L			0,7	1,4
			M			0,8	1,7
			S			0,9	1,9
			I			1,1	2,2

Note: 1) only available for connection in a round hole, not with the version with oblong hole.

Bolt factor	for $F_1$	for $F_{2/3}$
$k_{ax}$	$(f + 41,5) / 8$	1,87
$k_{lat}$	-	1,00

For each bolt it's needed to check:  $R_{bolt,d,lateral} \geq k_{lat} \times F_{i,d}$  ;  $R_{bolt,d,axial} \geq k_{ax} \times F_{i,d}$  ; and also the combination



**Table D34-5 Modified characteristic capacity timber beam to rigid support – 2 Angle Brackets, Nailing pattern 3**

2 Angle Brackets E4/2.5 per connection			Modified characteristic capacity per connection (kN)								
Nailing pattern	Number of Fasteners		Load duration	$R_{1,k} \times k_{mod}$				$R_{2/3,k} \times k_{mod} \text{ 1)}$			
	Flange A	Flange B		CNA4,0x35	CNA4,0x40	CNA4,0x50	CNA4,0x60	CNA4,0x35	CNA4,0x40	CNA4,0x50	CNA4,0x60
Nailing pattern 3	8	1 x Ø10 Bolt	P	7,6	7,6	7,6	7,6	3,4	3,9	4,9	5,4
			L	8,8	8,8	8,8	8,8	4,0	4,6	5,7	6,3
			M	10,1	10,1	10,1	10,1	4,6	5,2	6,5	7,2
			S	11,3	11,3	11,3	11,3	5,1	5,9	7,3	8,1
			I	13,9	13,9	13,9	13,9	6,3	7,2	8,9	9,9

**Note:** 1) only available for connection in a round hole, not with the version with oblong hole.

Bolt factor	for $F_1$	for $F_{2/3}$
$k_{ax}$	1,02	0,93
$k_{lat}$	-	0,50

For each bolt it's needed to check:  $R_{bolt,d,lateral} \geq k_{lat} \times F_{i,d}$  ;  $R_{bolt,d,axial} \geq k_{ax} \times F_{i,d}$ ; and also the combination

**General notes to all capacity tables:**

- b, e and f are in mm.
- Wane may not occur under the angle bracket.

## Annex D35 – E6/2

### Product Name:

Product Name	Material reference acc. to clause II-1	Alternative product names
E6/2	Steel ref. 1	-
E6/2S	Steel ref. 2	-
E6/2S2	Steel ref. 3	-

### Connector Size Range:

Model no.	Dimensions [mm]				Holes flange A		Holes flange B	
	A	B	C	Thickness	Ø5	Ø13	Ø5	12x20
E6/2	122	62	75	2,0	11	1	6	1 *)

\*) Optional round Hole Ø12

### Drawing:

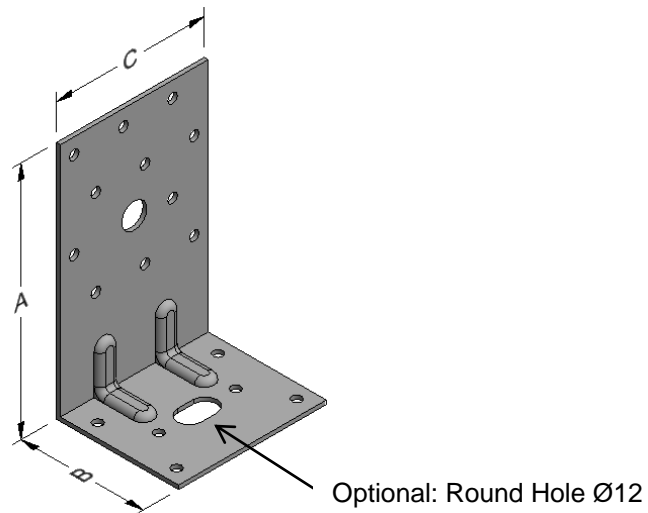

### Nailing pattern:

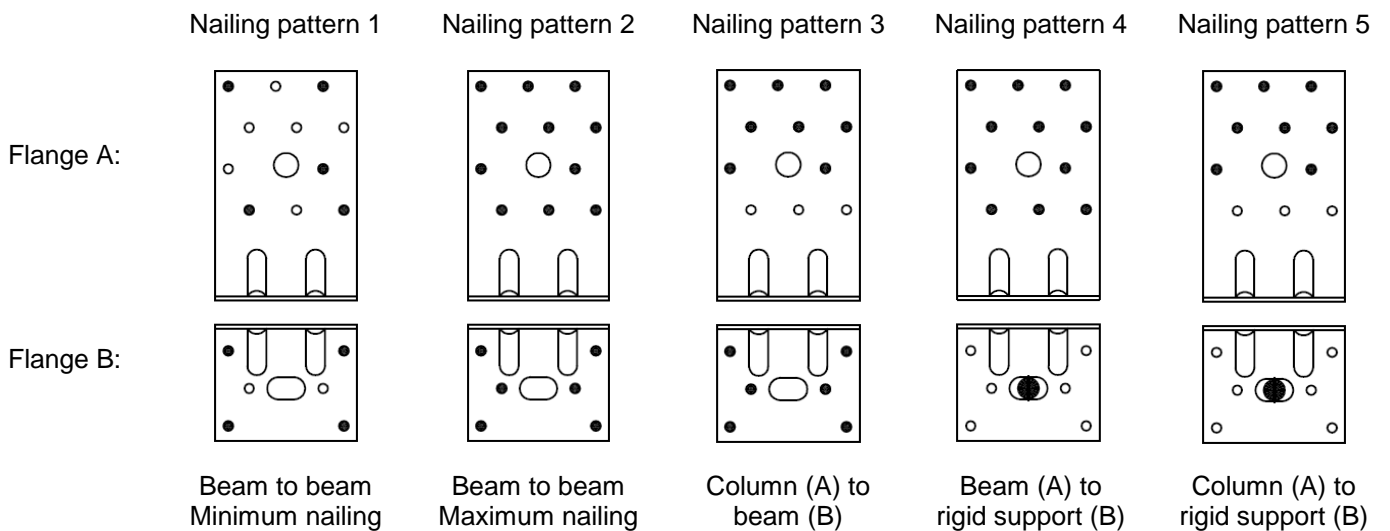

Table D35-1 Modified characteristic capacity timber beam to timber beam – 1 Angle Bracket, Nailing pattern 1

1 Angle Bracket E6/2 per connection			Modified characteristic capacity (kN)				
Nailing pattern	Number of fasteners		Load duration	$R_{1,k} \times k_{mod}$		$R_{2/3,k} \times k_{mod}$	
	Flange A	Flange B		4,0x35	4,0x60	4,0x35	4,0x60
Nailing pattern 1	5	4	P	$f \leq 36,2$ $32 / (f + 56)$	$f \leq 16,1$ $65 / (f + 56)$	1,2	2,2
				$f > 36,2$ $13,1 / (f + 1)$	$f > 16,1$ $13,1 / (f + 1)$		
			L	$f \leq 28$ $37 / (f + 56)$	$f \leq 13$ $75 / (f + 56)$	1,4	2,6
				$f > 28$ $13,1 / (f + 1)$	$f > 13$ $13,1 / (f + 1)$		
			M	$f \leq 22,8$ $43 / (f + 56)$	$f \leq 10,9$ $87 / (f + 56)$	1,6	3,0
				$f > 22,8$ $13,1 / (f + 1)$	$f > 10,9$ $13,1 / (f + 1)$		
			S	$f \leq 19,2$ $49 / (f + 56)$	$f \leq 9,3$ $97 / (f + 56)$	1,7	3,3
				$f > 19,2$ $13,1 / (f + 1)$	$f > 9,3$ $13,1 / (f + 1)$		
			I	$f \leq 14,5$ $59 / (f + 56)$	$f \leq 7,2$ $120 / (f + 56)$	2,2	4,1
				$f > 14,5$ $13,1 / (f + 1)$	$f > 7,2$ $13,1 / (f + 1)$		

Table D35-2 Modified characteristic capacity timber beam to timber beam – 1 Angle Bracket, Nailing pattern 2

1 Angle Bracket E6/2 per connection			Modified characteristic capacity (kN)				
Nailing pattern	Number of fasteners		Load duration	$R_{1,k} \times k_{mod}$		$R_{2/3,k} \times k_{mod}$	
	Flange A	Flange B		4,0x35	4,0x60	4,0x35	4,0x60
Nailing pattern 2	11	6	P	$f \leq 28,7$ $37 / (f + 56)$	$f \leq 13,3$ $75 / (f + 56)$	1,5	2,9
				$f > 28,7$ $13,1 / (f + 1)$	$f > 13,3$ $13,1 / (f + 1)$		
			L	$f \leq 22,7$ $44 / (f + 56)$	$f \leq 10,8$ $87 / (f + 56)$	1,8	3,4
				$f > 22,7$ $13,1 / (f + 1)$	$f > 10,8$ $13,1 / (f + 1)$		
			M	$f \leq 18,7$ $50 / (f + 56)$	$f \leq 9,1$ $99 / (f + 56)$	2,1	3,9
				$f > 18,7$ $13,1 / (f + 1)$	$f > 9,1$ $13,1 / (f + 1)$		
			S	$f \leq 15,8$ $56 / (f + 56)$	$f \leq 7,8$ $112 / (f + 56)$	2,4	4,3
				$f > 15,8$ $13,1 / (f + 1)$	$f > 7,8$ $13,1 / (f + 1)$		
			I	$f \leq 12$ $68 / (f + 56)$	$f \leq 6$ $136 / (f + 56)$	2,9	5,3
				$f > 12$ $13,1 / (f + 1)$	$f > 6$ $13,1 / (f + 1)$		

*Table D35-3 Modified characteristic capacity timber beam to timber beam – 2 Angle Brackets, Nailing pattern 1*

2 Angle Brackets E6/2 per connection			Modified characteristic capacities (kN)				
Nailing pattern	Number of Fasteners		Load duration	$R_{1,k} \times k_{mod}$		$R_{2/3,k} \times k_{mod}$	
	Flange A	Flange B		CNA4,0x35	CNA4,0x60	CNA4,0x35	CNA4,0x60
Nailing pattern 2	5	4	P	1,5	2,9	2,4	4,4
			L	1,7	3,5	2,8	5,1
			M	2,0	3,9	3,2	5,8
			S	2,2	4,4	3,6	6,6
			I	2,7	5,4	4,4	8,0

*Table D35-4 Modified characteristic capacity timber beam to timber beam – 2 Angle Brackets, Nailing pattern 2*

2 Angle Brackets E6/2 per connection			Modified characteristic capacities (kN)				
Nailing pattern	Number of Fasteners		Load duration	$R_{1,k} \times k_{mod}$		$R_{2/3,k} \times k_{mod}$	
	Flange A	Flange B		CNA4,0x35	CNA4,0x60	CNA4,0x35	CNA4,0x60
Nailing pattern 2	11	6	P	2,5	5,0	3,2	5,7
			L	3,0	5,8	3,7	6,7
			M	3,3	6,7	4,2	7,7
			S	3,8	7,5	4,7	8,7
			I	4,6	9,2	5,8	10,6

*Table D35-5 Modified characteristic capacity timber column to timber beam – 1 Angle Bracket Nailing pattern 2 & 3*

1 Angle Bracket E6/2 per connection		Modified characteristic capacity (kN)				
Number of fasteners		Load duration	$R_{1,k} \times k_{mod}$ Nailing pattern 3		$R_{2/3,k} \times k_{mod}$ Nailing pattern 2	
Flange A	Flange B		4,0x35	4,0x60	4,0x35	4,0x60
For $R_1$ : 8 For $R_{2/3}$ : 11	6	P	$f \leq 28,7$ $37 / (f + 56)$	$f \leq 13,3$ $75 / (f + 56)$	1,5	2,9
			$f > 28,7$ $13,1 / (f + 1)$	$f > 13,3$ $13,1 / (f + 1)$		
		L	$f \leq 22,7$ $43 / (f + 56)$	$f \leq 10,8$ $87 / (f + 56)$	1,8	3,4
			$f > 22,7$ $13,1 / (f + 1)$	$f > 10,8$ $13,1 / (f + 1)$		
		M	$f \leq 18,7$ $49 / (f + 56)$	$f \leq 9,1$ $99 / (f + 56)$	2,1	3,9
			$f > 18,7$ $13,1 / (f + 1)$	$f > 9,1$ $13,1 / (f + 1)$		
		S	$f \leq 15,8$ $56 / (f + 56)$	$f \leq 7,8$ $112 / (f + 56)$	2,4	4,3
			$f > 15,8$ $13,1 / (f + 1)$	$f > 7,8$ $13,1 / (f + 1)$		
		I	$f \leq 12$ $68 / (f + 56)$	$f \leq 6$ $136 / (f + 56)$	2,9	5,3
			$f > 12$ $13,1 / (f + 1)$	$f > 6$ $13,1 / (f + 1)$		

**Table D35-6 Modified characteristic capacity timber column to timber beam – 2 Angle Brackets Nailing pattern 2 & 3**

2 Angle Brackets E6/2 per connection			Modified characteristic capacities (kN)			
Number of Fasteners		Load duration	R <sub>1,k</sub> x k <sub>mod</sub> Nailing pattern 3		R <sub>2/3,k</sub> x k <sub>mod</sub> Nailing pattern 2	
Flange A	Flange B		CNA4,0x35	CNA4,0x60	CNA4,0x35	CNA4,0x60
For R <sub>1</sub> : 8 For R <sub>2/3</sub> : 11	6	P	2,5	5,0	3,2	5,8
		L	3,0	5,8	3,7	6,7
		M	3,3	6,7	4,2	7,7
		S	3,8	7,5	4,7	8,7
		I	4,6	9,2	5,8	10,6

**Table D35-7 Modified characteristic capacity timber beam to rigid support – 1 Angle Bracket, Nailing pattern 4**

1 Angle Bracket E6/2 per connection			Modified characteristic capacity (kN)			
Nailing pattern 4		Load duration	R <sub>1,k</sub> x k <sub>mod</sub>		R <sub>2/3,k</sub> x k <sub>mod</sub>	
Number of fasteners			4,0x35	4,0x60	4,0x35	4,0x60
Flange A	Flange B					
11	1 x Ø10 Bolt	P	Min of 10,9 / (f + 27) 13,1, / f		0,6	1,0
		L			0,7	1,2
		M			0,8	1,3
		S			0,9	1,5
		I			1,1	1,8

Bolt factor	for F <sub>1</sub>	for F <sub>2/3</sub>
k <sub>ax</sub>	(f + 41) / 8	0,53
k <sub>lat</sub>	-	1,00

For each bolt it's needed to check:  $R_{bolt,d,lateral} \geq k_{lat} \times F_{i,d}$  ;  $R_{bolt,d,axial} \geq k_{ax} \times F_{i,d}$  ; and also the combination

**Table D35-8 Modified characteristic capacity timber beam to rigid support – 2 Angle Brackets, Nailing pattern 4**

2 Angle Brackets E6/2 per connection		Modified characteristic capacities (kN)				
Nailing pattern 4		Load duration	R <sub>1,k</sub> x k <sub>mod</sub>		R <sub>2/3,k</sub> x k <sub>mod</sub>	
Number of Fasteners			CNA4,0x35	CNA4,0x60	CNA4,0x35	CNA4,0x60
Flange A	Flange B					
11	1 x Ø10 Bolt	P	3,9	7,7	1,2	2,0
		L	4,6	9,0	1,4	2,3
		M	5,2	9,7	1,6	2,6
		S	5,8	9,7	1,8	3,0
		I	7,2	9,7	2,2	3,7

Bolt factor	for F <sub>1</sub>	for F <sub>2/3</sub>
k <sub>ax</sub>	1,02	0,27
k <sub>lat</sub>	-	0,50

For each bolt it's needed to check:  $R_{bolt,d,lateral} \geq k_{lat} \times F_{i,d}$  ;  $R_{bolt,d,axial} \geq k_{ax} \times F_{i,d}$  ; and also the combination

**Table D35-9 Modified characteristic capacity timber column to rigid support – 1 Angle Bracket Nailing pattern 4 & 5**

1 Angle Bracket E6/2 per connection		Modified characteristic capacity (kN)				
Number of fasteners		Load duration	R <sub>1,k</sub> x k <sub>mod</sub>		R <sub>2/3,k</sub> x k <sub>mod</sub>	
			Nailing pattern5		Nailing pattern 4	
Flange A	Flange B		4,0x35	4,0x60	4,0x35	4,0x60
For R <sub>1</sub> : 8 For R <sub>2/3</sub> : 11	1 x Ø10 Bolt	P	Min of 10,9 / (f+27) 13,1, / f		0,6	1,0
		L			0,7	1,2
		M			0,8	1,3
		S			0,9	1,5
		I			1,1	1,8

Bolt factor	for F <sub>1</sub>	for F <sub>2/3</sub>
k <sub>ax</sub>	(f + 41) / 8	0,53
k <sub>lat</sub>	-	1,00

For each bolt it's needed to check:  $R_{bolt,d,lateral} \geq k_{lat} \times F_{i,d}$  ;  $R_{bolt,d,axial} \geq k_{ax} \times F_{i,d}$  ; and also the combination



*Table D35-10 Modified characteristic capacity timber column to rigid support – 2 Angle Brackets Nailing pattern 4 & 5*

2 Angle Brackets E6/2 per connection		Modified characteristic capacities (kN)				
Number of Fasteners		Load duration	$R_{1,k} \times k_{mod}$ Nailing pattern 5		$R_{2/3,k} \times k_{mod}$ Nailing pattern 4	
Flange A	Flange B		CNA4,0x35	CNA4,0x60	CNA4,0x35	CNA4,0x60
For $R_1$ : 8 For $R_{2/3}$ : 11	1 x Ø10 Bolt	P	2,0	4,0	1,2	2,0
		L	2,2	4,6	1,4	2,3
		M	2,6	5,3	1,6	2,6
		S	3,0	5,9	1,8	3,0
		I	3,7	7,3	2,2	3,7

Bolt factor	for $F_1$	for $F_{2/3}$
$k_{ax}$	1,02	0,27
$k_{lat}$	-	0,50

For each bolt it's needed to check:  $R_{bolt,d,lateral} \geq k_{lat} \times F_{i,d}$  ;  $R_{bolt,d,axial} \geq k_{ax} \times F_{i,d}$ ; and also the combination

General note to all capacity tables:

- b, e and f are in mm.
- Wane may not occur under the angle bracket.

## Annex D36 – E6/2,5

### Product Name:

Product Name	Material reference acc. to clause II-1	Alternative product names
E6/2,5	Steel ref. 1	-
E6/2,5S	Steel ref. 2	-
E6/2,5S2	Steel ref. 3	-

### Connector Size Range:

Model no.	Dimensions [mm]				Holes flange A		Holes flange B	
	A	B	C	Thickness s	Ø5	Ø13	Ø5	12x20
E6/2,5	122,5	62,5	75	2,5	11	1	6	1 *)

\*) Optional round Hole Ø12

### Drawing:

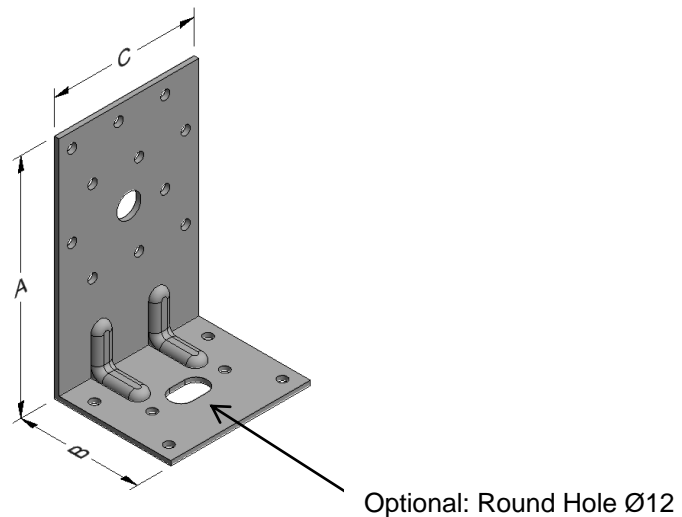

### Nailing pattern:

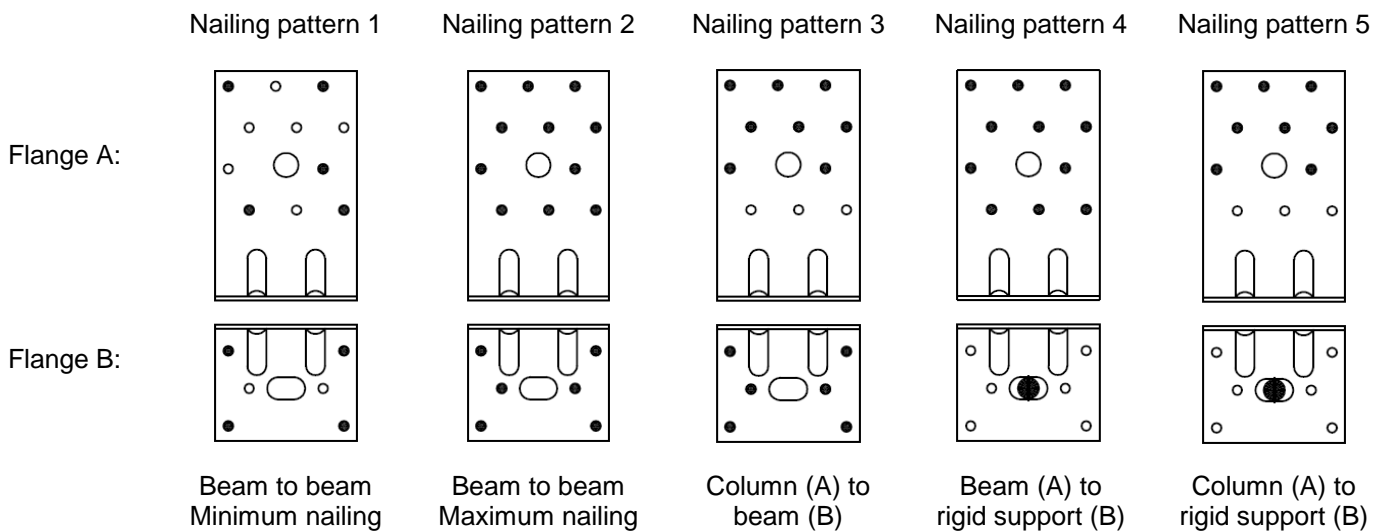

*Table D36-1 Modified characteristic capacity timber beam to timber beam – 1 Angle Bracket, Nailing pattern 1*

1 Angle Bracket E6/2.5 per connection		Modified characteristic capacity (kN)				
Nailing pattern 1		Load duration	$R_{1,k} \times k_{mod}$		$R_{2/3,k} \times k_{mod}$	
Number of fasteners			4,0x35	4,0x60	4,0x35	4,0x60
Flange A	Flange B					
5	4	P	$f \leq 92,8$ $32 / (f + 56)$	$f \leq 31,2$ $65 / (f + 56)$	1,2	2,1
			$f > 92,8$ $20,5 / (f + 1)$	$f > 31,2$ $20,5 / (f + 1)$		
		L	$f \leq 63,6$ $37 / (f + 56)$	$f \leq 24,4$ $75 / (f + 56)$	1,5	2,5
			$f > 63,6$ $20,5 / (f + 1)$	$f > 24,4$ $20,5 / (f + 1)$		
		M	$f \leq 48,2$ $43 / (f + 56)$	$f \leq 20$ $87 / (f + 56)$	1,7	3,0
			$f > 48,2$ $20,5 / (f + 1)$	$f > 20$ $20,5 / (f + 1)$		
		S	$f \leq 38,8$ $49 / (f + 56)$	$f \leq 16,8$ $97 / (f + 56)$	1,8	3,3
			$f > 38,8$ $20,5 / (f + 1)$	$f > 16,8$ $20,5 / (f + 1)$		
		I	$f \leq 27,7$ $59 / (f + 56)$	$f \leq 12,7$ $120 / (f + 56)$	2,2	4,0
			$f > 27,7$ $20,5 / (f + 1)$	$f > 12,7$ $20,5 / (f + 1)$		

*Table D36-2 Modified characteristic capacity timber beam to timber beam – 1 Angle Bracket, Nailing pattern 2*

1 Angle Bracket E6/2.5 per connection		Modified characteristic capacity (kN)				
Nailing pattern 2		Load duration	$R_{1,k} \times k_{mod}$		$R_{2/3,k} \times k_{mod}$	
Number of fasteners			4,0x35	4,0x60	4,0x35	4,0x60
Flange A	Flange B					
11	6	P	$f \leq 65,9$ $37 / (f + 56)$	$f \leq 25$ $75 / (f + 56)$	1,5	2,9
			$f > 65,9$ $20,5 / (f + 1)$	$f > 25$ $20,5 / (f + 1)$		
		L	$f \leq 47,8$ $43 / (f + 56)$	$f \leq 19,8$ $87 / (f + 56)$	1,8	3,3
			$f > 47,8$ $20,5 / (f + 1)$	$f > 19,8$ $20,5 / (f + 1)$		
		M	$f \leq 37,4$ $50 / (f + 56)$	$f \leq 16,3$ $99 / (f + 56)$	2,1	3,9
			$f > 37,4$ $20,5 / (f + 1)$	$f > 16,3$ $20,5 / (f + 1)$		
		S	$f \leq 30,6$ $56 / (f + 56)$	$f \leq 13,9$ $112 / (f + 56)$	2,4	4,3
			$f > 30,6$ $20,5 / (f + 1)$	$f > 13,9$ $20,5 / (f + 1)$		
		I	$f \leq 22,3$ $68 / (f + 56)$	$f \leq 10,5$ $136 / (f + 56)$	2,9	5,3
			$f > 22,3$ $20,5 / (f + 1)$	$f > 10,5$ $20,5 / (f + 1)$		

*Table D36-3 Modified characteristic capacity timber beam to timber beam – 2 Angle Brackets, Nailing pattern 2*

2 Angle Brackets E6/2.5 per connection		Modified characteristic capacities (kN)								
Nailing pattern 2		Load duration	$R_{1,k} \times k_{mod}$				$R_{2/3,k} \times k_{mod}$			
Number of Fasteners			CNA4,0x35	CNA4,0x40	CNA4,0x50	CNA4,0x60	CNA4,0x35	CNA4,0x40	CNA4,0x50	CNA4,0x60
Flange A	Flange B									
11	6	P	2,8	3,2	3,6	3,8	4,7	5,2	6,3	6,7
		L	3,9	4,4	5,0	5,3	6,6	7,2	8,8	9,3
		M	4,4	5,0	5,8	6,1	7,5	8,2	10,0	10,6
		S	5,0	5,7	6,5	6,8	8,5	9,3	11,3	12,0
		I	6,1	6,9	7,9	8,4	10,3	11,3	13,8	14,6

**Table D36-4** Modified characteristic capacity timber column to timber beam – 1 Angle Bracket, Nailing pattern 2 & 3

1 Angle Bracket E6/2.5 per connection		Modified characteristic capacity (kN)				
Number of fasteners		Load duration	$R_{1,k} \times k_{mod}$		$R_{2/3,k} \times k_{mod}$	
Flange A	Flange B		Nailing pattern 3		Nailing pattern 2	
			4,0x35	4,0x60	4,0x35	4,0x60
For $R_1$ : 8 For $R_{2/3}$ : 11	6	P	$f \leq 65,9$ $37 / (f + 56)$	$f \leq 25$ $75 / (f + 56)$	1,5	2,9
			$f > 65,9$ $20,5 / (f + 1)$	$f > 25$ $20,5 / (f + 1)$		
		L	$f \leq 47,8$ $43 / (f + 56)$	$f \leq 19,8$ $87 / (f + 56)$	1,8	3,4
			$f > 47,8$ $20,5 / (f + 1)$	$f > 19,8$ $20,5 / (f + 1)$		
		M	$f \leq 37,4$ $49 / (f + 56)$	$f \leq 16,3$ $99 / (f + 56)$	2,1	3,9
			$f > 37,4$ $20,5 / (f + 1)$	$f > 16,3$ $20,5 / (f + 1)$		
		S	$f \leq 30,6$ $56 / (f + 56)$	$f \leq 13,9$ $112 / (f + 56)$	2,4	4,3
			$f > 30,6$ $20,5 / (f + 1)$	$f > 13,9$ $20,5 / (f + 1)$		
		I	$f \leq 22,3$ $68 / (f + 56)$	$f \leq 10,5$ $136 / (f + 56)$	2,9	5,3
			$f > 22,3$ $20,5 / (f + 1)$	$f > 10,5$ $20,5 / (f + 1)$		

**Table D36-5 Modified characteristic capacity timber column to timber beam – 2 Angle Brackets Nailing pattern 2 & 3**

2 Angle Brackets E6/2.5 per connection		Modified characteristic capacities (kN)				
Number of Fasteners		Load duration	R <sub>1,k</sub> x k <sub>mod</sub>		R <sub>2/3,k</sub> x k <sub>mod</sub>	
			Nailing pattern 3		Nailing pattern 2	
Flange A	Flange B		CNA4,0x35	CNA4,0x60	CNA4,0x35	CNA4,0x60
For R <sub>1</sub> : 8 For R <sub>2/3</sub> : 11	6	P	2,5	5,0	3,2	5,8
		L	3,0	5,8	3,7	6,7
		M	3,3	6,7	4,2	7,7
		S	3,8	7,5	4,7	8,7
		I	4,6	9,2	5,8	10,6

**Table D36-6 Modified characteristic capacity timber beam to rigid support – 1 Angle Bracket, Nailing pattern 4**

1 Angle Bracket E6/2.5 per connection		Modified characteristic capacity (kN)				
Nailing pattern 4		Load duration	R <sub>1,k</sub> x k <sub>mod</sub>		R <sub>2/3,k</sub> x k <sub>mod</sub>	
Number of fasteners			4,0x35	4,0x60	4,0x35	4,0x60
Flange A	Flange B					
11	1 x Ø10 Bolt	P	Min of 14,9 / (f + 27)  20,5 / f		0,6	1,2
		L			0,7	1,4
		M			0,8	1,7
		S			0,9	1,9
		I			1,1	2,2

Bolt factor	for F <sub>1</sub>	for F <sub>2/3</sub>
k <sub>ax</sub>	(f + 41,5) / 8	1,87
k <sub>lat</sub>	-	1,00

For each bolt it's needed to check:  $R_{bolt,d,lateral} \geq k_{lat} \times F_{i,d}$  ;  $R_{bolt,d,axial} \geq k_{ax} \times F_{i,d}$ ; and also the combination

**Table D36-7 Modified characteristic capacity timber beam to rigid support – 2 Angle Brackets, Nailing pattern 4**

2 Angle Brackets E6/2.5 per connection		Modified characteristic capacities (kN)								
Nailing pattern 4		Load duration	$R_{1,k} \times k_{mod}$				$R_{2/3,k} \times k_{mod} \ 1)$			
Number of Fasteners										
Flange A	Flange B		CNA4,0x35	CNA4,0x40	CNA4,0x50	CNA4,0x60	CNA4,0x35	CNA4,0x40	CNA4,0x50	CNA4,0x60
11	1 x Ø10 Bolt	P	6,3	6,3	6,3	6,3	2,9	3,3	4,1	4,5
		L	8,8	8,8	8,8	8,8	4,0	4,6	5,7	6,3
		M	10,1	10,1	10,1	10,1	4,6	5,2	6,5	7,2
		S	11,3	11,3	11,3	11,3	5,1	5,9	7,3	8,1
		I	13,9	13,9	13,9	13,9	6,3	7,2	8,9	9,9

Note: 1) only available for connection in a round hole, not with the version with oblong hole.

Bolt factor	for $F_1$	for $F_{2/3}$
$k_{ax}$	1,02	0,93
$k_{lat}$	-	0,50

For each bolt it's needed to check:  $R_{bolt,d,lateral} \geq k_{lat} \times F_{i,d}$  ;  $R_{bolt,d,axial} \geq k_{ax} \times F_{i,d}$ ; and also the combination

**Table D36-8 Modified characteristic capacity timber column to rigid support – 1 Angle Bracket, Nailing pattern 4 & 5**

1 Angle Bracket E6/2.5 per connection		Modified characteristic capacity (kN)				
Number of fasteners		Load duration	$R_{1,k} \times k_{mod}$		$R_{2/3,k} \times k_{mod}$	
			Nailing pattern5		Nailing pattern 4	
Flange A	Flange B		4,0x35	4,0x60	4,0x35	4,0x60
For $R_1$ : 8 For $R_{2/3}$ : 11	1 x Ø10 Bolt	P	14,9 / (f + 28)		0,6	1,2
		L			0,7	1,4
		M			0,8	1,7
		S			0,9	1,9
		I			1,1	2,2

Bolt factor	for $F_1$	for $F_{2/3}$
$k_{ax}$	(f + 41,5) / 8	1,87
$k_{lat}$	-	1,00

For each bolt it's needed to check:  $R_{bolt,d,lateral} \geq k_{lat} \times F_{i,d}$  ;  $R_{bolt,d,axial} \geq k_{ax} \times F_{i,d}$ ; and also the combination



Table D36-9 Modified characteristic capacity timber column to rigid support – 2 Angle Brackets Nailing pattern 4 &amp; 5

2 Angle Brackets E6/2.5 per connection		Modified characteristic capacities (kN)				
Number of Fasteners		Load duration	$R_{1,k} \times k_{mod}$ Nailing pattern 5		$R_{2/3,k} \times k_{mod}$ Nailing pattern 4	
Flange A	Flange B		CNA4,0x35	CNA4,0x60	CNA4,0x35	CNA4,0x60
For $R_1$ : 8 For $R_{2/3}$ : 11	1 x Ø10 Bolt	P	2,0	4,0	1,2	2,5
		L	2,2	4,6	1,4	2,8
		M	2,6	5,3	1,6	3,3
		S	3,0	5,9	1,7	3,8
		I	3,7	7,3	2,2	4,6

Bolt factor	for $F_1$	for $F_{2/3}$
$k_{ax}$	1,02	0,93
$k_{lat}$	-	0,50

For each bolt it's needed to check:  $R_{bolt,d,lateral} \geq k_{lat} \times F_{i,d}$  ;  $R_{bolt,d,axial} \geq k_{ax} \times F_{i,d}$  ; and also the combination

General note to all capacity tables:

- b, e and f are in mm.
- Wane may not occur under the angle bracket.

## Annex D37 – E7/2,5

### Product Name:

Product Name	Material reference acc. to clause II-1	Alternative product names
E7/2,5	Steel ref. 1	-
E7/2,5S	Steel ref. 2	-
E7/2,5S2	Steel ref. 3	-

### Connector Size Range:

Model no.	Dimensions [mm]				Holes flange A		Holes flange B	
	A	B	C	Thickness	Ø5	Ø13	Ø5	12x20
E7/2,5	142,5	62,5	75	2,5	13	1	6	1 *)

\*) Optional round Hole Ø12

### Drawing:

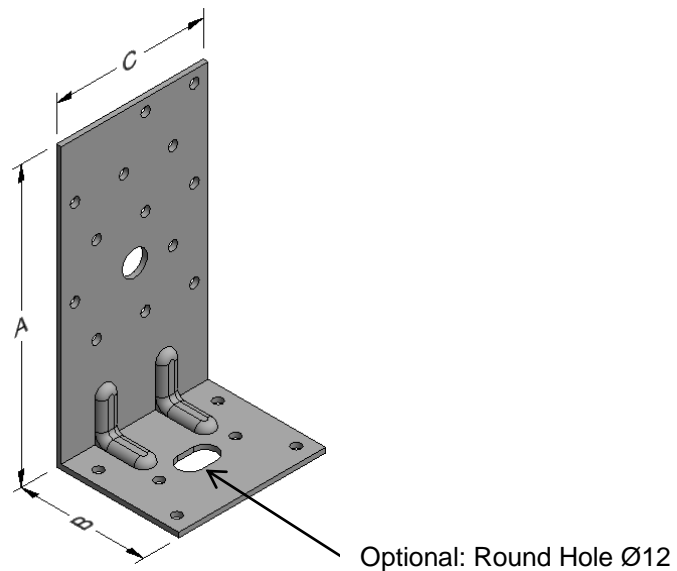

### Nailing pattern:

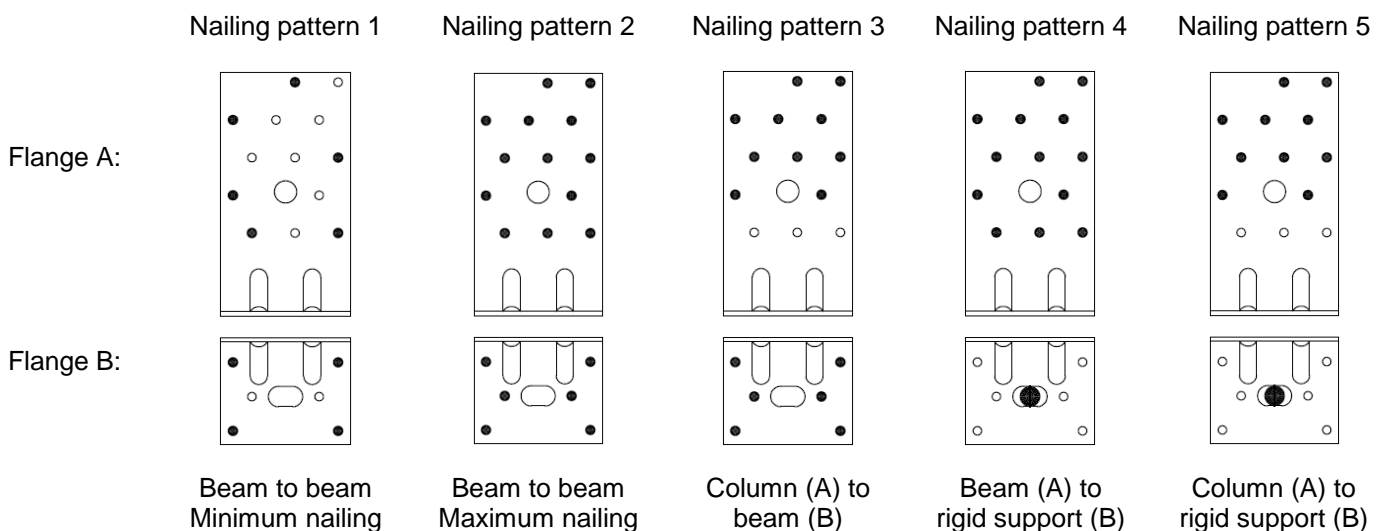

*Table D37-1 Modified characteristic capacity timber beam to timber beam – 1 Angle Bracket, Nailing pattern 1*

1 Angle Bracket E7/2.5 per connection		Modified characteristic capacity (kN)				
Nailing pattern 1		Load duration	$R_{1,k} \times k_{mod}$		$R_{2/3,k} \times k_{mod}$	
Number of fasteners			4,0x35	4,0x60	4,0x35	4,0x60
Flange A	Flange B					
6	4	P	$f \leq 92,8$ $32 / (f + 56)$	$f \leq 31,2$ $65 / (f + 56)$	1,3	2,5
			$f > 92,8$ $20,5 / (f + 1)$	$f > 31,2$ $20,5 / (f + 1)$		
		L	$f \leq 63,6$ $37 / (f + 56)$	$f \leq 24,4$ $75 / (f + 56)$	1,5	2,9
			$f > 63,6$ $20,5 / (f + 1)$	$f > 24,4$ $20,5 / (f + 1)$		
		M	$f \leq 48,2$ $43 / (f + 56)$	$f \leq 20$ $87 / (f + 56)$	1,7	3,4
			$f > 48,2$ $20,5 / (f + 1)$	$f > 20$ $20,5 / (f + 1)$		
		S	$f \leq 38,8$ $49 / (f + 56)$	$f \leq 16,8$ $97 / (f + 56)$	1,9	3,8
			$f > 38,8$ $20,5 / (f + 1)$	$f > 16,8$ $20,5 / (f + 1)$		
		I	$f \leq 27,7$ $59 / (f + 56)$	$f \leq 12,7$ $119 / (f + 56)$	2,3	4,6
			$f > 27,7$ $20,5 / (f + 1)$	$f > 12,7$ $20,5 / (f + 1)$		

Table D37-2 Modified characteristic capacity timber beam to timber beam – 1 Angle Bracket, Nailing pattern 2

1 Angle Bracket E7/2.5 per connection		Modified characteristic capacity (kN)				
Nailing pattern 2		Load duration	$R_{1,k} \times k_{mod}$		$R_{2/3,k} \times k_{mod}$	
Number of fasteners			4,0x35	4,0x60	4,0x35	4,0x60
Flange A	Flange B					
13	6	P	$f \leq 65,9$ $37 / (f + 56)$	$f \leq 25$ $75 / (f + 56)$	2,0	3,7
			$f > 65,9$ $20,5 / (f + 1)$	$f > 25$ $20,5 / (f + 1)$		
		L	$f \leq 47,8$ $43 / (f + 56)$	$f \leq 19,8$ $87 / (f + 56)$	2,3	4,4
			$f > 47,8$ $20,5 / (f + 1)$	$f > 19,8$ $20,5 / (f + 1)$		
		M	$f \leq 37,4$ $49 / (f + 56)$	$f \leq 16,3$ $99 / (f + 56)$	2,6	5,0
			$f > 37,4$ $20,5 / (f + 1)$	$f > 16,3$ $20,5 / (f + 1)$		
		S	$f \leq 30,6$ $56 / (f + 56)$	$f \leq 13,9$ $112 / (f + 56)$	3,0	5,6
			$f > 30,6$ $20,5 / (f + 1)$	$f > 13,9$ $20,5 / (f + 1)$		
		I	$f \leq 22,3$ $68 / (f + 56)$	$f \leq 10,5$ $136 / (f + 56)$	3,7	6,9
			$f > 22,3$ $20,5 / (f + 1)$	$f > 10,5$ $20,5 / (f + 1)$		

*Table D37-3 Modified characteristic capacity timber beam to timber beam – 2 Angle Brackets, Nailing pattern 1*

2 Angle Brackets E7/2.5 per connection			Modified characteristic capacities (kN)							
Nailing pattern 1		Load duration	$R_{1,k} \times k_{mod}$				$R_{2/3,k} \times k_{mod}$			
Number of Fasteners			CNA4,0x35	CNA4,0x40	CNA4,0x50	CNA4,0x60	CNA4,0x35	CNA4,0x40	CNA4,0x50	CNA4,0x60
Flange A	Flange B									
6	4	P	1,2	1,4	2,3	2,5	2,2	2,4	4,0	4,3
		L	1,7	2,0	3,2	3,4	3,0	3,3	5,5	6,0
		M	1,9	2,2	3,7	3,9	3,4	3,8	6,3	6,8
		S	2,2	2,5	4,1	4,4	3,9	4,2	7,1	7,7
		I	2,6	3,1	5,1	5,4	4,7	5,2	8,7	9,4

*Table D37-4 Modified characteristic capacity timber beam to timber beam – 2 Angle Brackets, Nailing pattern 2*

2 Angle Brackets E7/2.5 per connection			Modified characteristic capacities (kN)							
Nailing pattern 2		Load duration	$R_{1,k} \times k_{mod}$				$R_{2/3,k} \times k_{mod}$			
Number of Fasteners			CNA4,0x35	CNA4,0x40	CNA4,0x50	CNA4,0x60	CNA4,0x35	CNA4,0x40	CNA4,0x50	CNA4,0x60
Flange A	Flange B									
13	6	P	2,8	3,2	3,6	3,8	5,0	5,5	6,7	7,1
		L	3,9	4,4	5,0	5,3	7,0	7,6	9,3	9,9
		M	4,4	5,0	5,8	6,1	8,0	8,7	10,6	11,4
		S	5,0	5,7	6,5	6,8	9,0	9,8	12,0	12,8
		I	6,1	6,9	7,9	8,4	11,0	12,0	14,6	15,6

**Table D37-5** Modified characteristic capacity timber column to timber beam – 1 Angle Bracket, Nailing pattern 2 & 3

1 Angle Bracket E7/2.5 per connection		Modified characteristic capacity (kN)				
Number of fasteners		Load duration	$R_{1,k} \times k_{mod}$ Nailing pattern 3		$R_{2/3,k} \times k_{mod}$ Nailing pattern 2	
Flange A	Flange B		4,0x35	4,0x60	4,0x35	4,0x60
For $R_1$ : 10 For $R_{2/3}$ : 13	6	P	$f \leq 65,9$ $37 / (f + 56)$	$f \leq 25$ $74 / (f + 56)$	1,8	3,7
			$f > 65,9$ $20,5 / (f + 1)$	$f > 25$ $20,5 / (f + 1)$		
		L	$f \leq 47,8$ $43 / (f + 56)$	$f \leq 19,8$ $87 / (f + 56)$	2,1	4,3
			$f > 47,8$ $20,5 / (f + 1)$	$f > 19,8$ $20,5 / (f + 1)$		
		M	$f \leq 37,4$ $49 / (f + 56)$	$f \leq 16,3$ $99 / (f + 56)$	2,5	4,8
			$f > 37,4$ $20,5 / (f + 1)$	$f > 16,3$ $20,5 / (f + 1)$		
		S	$f \leq 30,6$ $56 / (f + 56)$	$f \leq 13,9$ $112 / (f + 56)$	2,8	5,5
			$f > 30,6$ $20,5 / (f + 1)$	$f > 13,9$ $20,5 / (f + 1)$		
		I	$f \leq 22,3$ $68 / (f + 56)$	$f \leq 10,5$ $136 / (f + 56)$	3,4	6,7
			$f > 22,3$ $20,5 / (f + 1)$	$f > 10,5$ $20,5 / (f + 1)$		

**Table D37-6 Modified characteristic capacity timber column to timber beam – 2 Angle Brackets, Nailing pattern 2 & 3**

2 Angle Brackets E7/2.5 per connection			Modified characteristic capacities (kN)			
Number of Fasteners		Load duration	R <sub>1,k</sub> x k <sub>mod</sub> Nailing pattern 3		R <sub>2/3,k</sub> x k <sub>mod</sub> Nailing pattern 2	
Flange A	Flange B		CNA4,0x35	CNA4,0x60	CNA4,0x35	CNA4,0x60
For R <sub>1</sub> : 10 For R <sub>2/3</sub> : 13	6	P	2,5	5,0	3,7	7,3
		L	2,9	5,8	4,3	8,5
		M	3,3	6,7	4,9	9,8
		S	3,7	7,5	5,6	10,9
		I	4,5	9,2	6,8	13,4

**Table D37-7 Modified characteristic capacity timber beam to rigid support – 1 Angle Bracket, Nailing pattern 4**

1 Angle Bracket E7/2.5 per connection			Modified characteristic capacity (kN)							
Nailing pattern 4		Load duration	R <sub>1,k</sub> x k <sub>mod</sub>				R <sub>2/3,k</sub> x k <sub>mod</sub> 1)			
Number of fasteners			4,0x35	4,0x40	4,0x50	4,0x60	4,0x35	4,0x40	4,0x50	4,0x60
Flange A	Flange B									
13	1 x Ø10 Bolt	P	19,2 / (f + 28)				0,6	0,7	1,1	1,2
		L					0,7	0,8	1,3	1,4
		M					0,8	0,9	1,4	1,6
		S					0,9	1,0	1,6	1,8
		I					1,1	1,2	2,0	2,2

Note: 1) only available for connection in a round hole, not with the version with oblong hole.

Bolt factor	for F <sub>1</sub>	for F <sub>2/3</sub>
k <sub>ax</sub>	(f + 41,5) / 8	1,87
k <sub>lat</sub>	-	1,00

For each bolt it's needed to check:  $R_{bolt,d,lateral} \geq k_{lat} \times F_{i,d}$  ;  $R_{bolt,d,axial} \geq k_{ax} \times F_{i,d}$  ; and also the combination

*Table D37-8 Modified characteristic capacity timber beam to rigid support – 2 Angle Brackets, Nailing pattern 4*

2 Angle Brackets E7/2.5 per connection			Modified characteristic capacities (kN)							
Nailing pattern 4		Load duration	$R_{1,k} \times k_{mod}$				$R_{2/3,k} \times k_{mod}$ 1)			
Number of Fasteners			CNA4,0x35	CNA4,0x40	CNA4,0x50	CNA4,0x60	CNA4,0x35	CNA4,0x40	CNA4,0x50	CNA4,0x60
Flange A	Flange B									
13	1 x Ø10 Bolt	P	6,4	6,4	6,4	6,4	2,9	3,3	4,1	4,5
		L	8,9	8,9	8,9	8,9	4,0	4,6	5,7	6,3
		M	10,2	10,2	10,2	10,2	4,6	5,2	6,5	7,2
		S	11,4	11,4	11,4	11,4	5,1	5,9	7,3	8,1
		I	14,0	14,0	14,0	14,0	6,3	7,2	8,9	9,9

Note: 1) only available for connection in a round hole, not with the version with oblong hole.

Bolt factor	for $F_1$	for $F_{2/3}$
$k_{ax}$	1,02	0,93
$k_{lat}$	-	0,50

For each bolt it's needed to check:  $R_{bolt,d,lateral} \geq k_{lat} \times F_{i,d}$  ;  $R_{bolt,d,axial} \geq k_{ax} \times F_{i,d}$  ; and also the combination



**Table D37-9 Modified characteristic capacity timber column to rigid support – 1 Angle Bracket, Nailing pattern 4 & 5**

1 Angle Bracket E7/2.5 per connection		Modified characteristic capacity (kN)				
Number of fasteners		Load duration	$R_{1,k} \times k_{mod}$ Nailing pattern 5		$R_{2/3,k} \times k_{mod}$ Nailing pattern 4	
Flange A	Flange B		4,0x35	4,0x60	4,0x35	4,0x60
For $R_1$ : 10 For $R_{2/3}$ : 13	1 x Ø10 Bolt	P	$f \leq 23,4$ 8 / f	19,2 / ( f + 28 )	0,6	1,2
			$f > 23,4$ 19,2 / ( f + 28 )			
		L	$f \leq 31,9$ 10 / f		0,7	1,4
			$f > 31,9$ 19,2 / ( f + 28 )			
		M	$f \leq 43,6$ 11 / f		0,8	1,7
			$f > 43,6$ 19,2 / ( f + 28 )			
		S	$f \leq 61,2$ 13 / f		0,9	1,9
			$f > 61,2$ 19,2 / ( f + 28 )			
I	$f \leq 148$ 16,2 / f	1,1	2,2			
	$f > 148$ 19,2 / ( f + 28 )					

Bolt factor	for $F_1$	for $F_{2/3}$
$k_{ax}$	$(f + 41,5) / 8$	1,87
$k_{lat}$	-	1,00

For each bolt it's needed to check:  $R_{bolt,d,lateral} \geq k_{lat} \times F_{i,d}$  ;  $R_{bolt,d,axial} \geq k_{ax} \times F_{i,d}$  ; and also the combination

Table D37-10 Modified characteristic capacity timber column to rigid support – 2 Angle Brackets, Nailing pattern 4 & 5

2 Angle Brackets E7/2.5 per connection		Modified characteristic capacities (kN)				
Number of Fasteners		Load duration	$R_{1,k} \times k_{mod}$ Nailing pattern 5		$R_{2/3,k} \times k_{mod}$ Nailing pattern 4	
Flange A	Flange B		CNA4,0x35	CNA4,0x60	CNA4,0x35	CNA4,0x60
For $R_1$ : 10 For $R_{2/3}$ : 13	1 x Ø10 Bolt	P	2,0	4,0	1,1	2,5
		L	2,3	4,6	1,4	2,8
		M	2,6	5,3	1,6	3,3
		S	3,0	6,0	1,8	3,7
		I	3,7	7,3	2,2	4,6

Bolt factor	for $F_1$	for $F_{2/3}$
$k_{ax}$	1,02	0,93
$k_{lat}$	-	0,50

For each bolt it's needed to check:  $R_{bolt,d,lateral} \geq k_{lat} \times F_{i,d}$  ;  $R_{bolt,d,axial} \geq k_{ax} \times F_{i,d}$  ; and also the combination

General note to all capacity tables:

- b, e and f are in mm.
- Wane may not occur under the angle bracket.

## Annex D38 – E8/2,5

### Product Name:

Product Name	Material reference acc. to clause II-1	Alternative product names
E8/2,5	Steel ref. 1	-
E8/2,5S	Steel ref. 2	-
E8/2,5S2	Steel ref. 3	-

### Connector Size Range:

Model no.	Dimensions [mm]				Holes flange A		Holes flange B	
	A	B	C	Thickness	Ø5	Ø13	Ø5	12x20
E8/2,5	162,5	62,5	75	2,5	13	2	6	1 *)

\*) Optional round Hole Ø12

### Drawing:

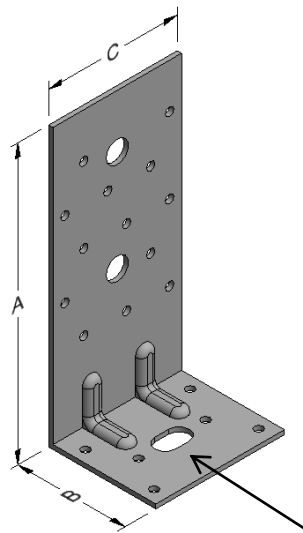

Optional: Round Hole Ø12

### Nailing pattern:

Nailing pattern 1

Nailing pattern 2

Nailing pattern 3

Nailing pattern 4

Nailing pattern 5

Flange A:

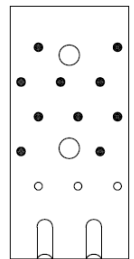
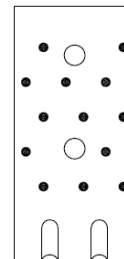
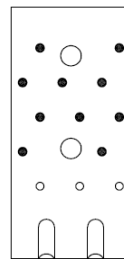
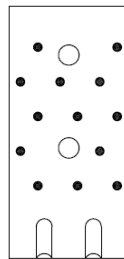
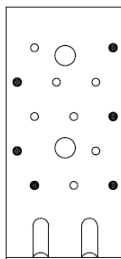

Flange B:

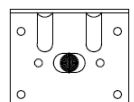
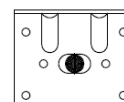
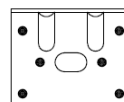
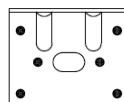
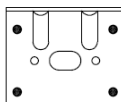

Beam to beam  
Minimum nailing

Beam to beam  
Maximum nailing

Column (A) to  
beam (B)

Beam (A) to  
rigid support (B)

Column (A) to  
rigid support (B)

*Table D38-1 Modified characteristic capacity timber beam to timber beam – 1 Angle Bracket, Nailing pattern 1*

1 Angle Bracket E8/2.5 per connection		Modified characteristic capacity (kN)				
Nailing pattern 1		Load duration	$R_{1,k} \times k_{mod}$		$R_{2/3,k} \times k_{mod}$	
Number of fasteners			4,0x35	4,0x60	4,0x35	4,0x60
Flange A	Flange B					
6	4	P	$f \leq 92,8$ $32 / (f + 56)$	$f \leq 31,2$ $65 / (f + 56)$	1,3	2,5
			$f > 92,8$ $20,5 / (f + 1)$	$f > 31,2$ $20,5 / (f + 1)$		
		L	$f \leq 63,6$ $37 / (f + 56)$	$f \leq 24,4$ $75 / (f + 56)$	1,5	2,9
			$f > 63,6$ $20,5 / (f + 1)$	$f > 24,4$ $20,5 / (f + 1)$		
		M	$f \leq 48,2$ $43 / (f + 56)$	$f \leq 20$ $87 / (f + 56)$	1,7	3,4
			$f > 48,2$ $20,5 / (f + 1)$	$f > 20$ $20,5 / (f + 1)$		
		S	$f \leq 38,8$ $49 / (f + 56)$	$f \leq 16,8$ $97 / (f + 56)$	1,9	3,8
			$f > 38,8$ $20,5 / (f + 1)$	$f > 16,8$ $20,5 / (f + 1)$		
		I	$f \leq 27,7$ $59 / (f + 56)$	$f \leq 12,7$ $119 / (f + 56)$	2,3	4,6
			$f > 27,7$ $20,5 / (f + 1)$	$f > 12,7$ $20,5 / (f + 1)$		

Table D38-2 Modified characteristic capacity timber beam to timber beam – 1 Angle Bracket, Nailing pattern 2

1 Angle Bracket E8/2.5 per connection		Modified characteristic capacity (kN)				
Nailing pattern 2		Load duration	$R_{1,k} \times k_{mod}$		$R_{2/3,k} \times k_{mod}$	
Number of fasteners			4,0x35	4,0x60	4,0x35	4,0x60
Flange A	Flange B					
13	6	P	$f \leq 65,9$ $37 / (f + 56)$	$f \leq 25$ $75 / (f + 56)$	2,0	3,7
			$f > 65,9$ $20,5 / (f + 1)$	$f > 25$ $20,5 / (f + 1)$		
		L	$f \leq 47,8$ $43 / (f + 56)$	$f \leq 19,8$ $87 / (f + 56)$	2,3	4,4
			$f > 47,8$ $20,5 / (f + 1)$	$f > 19,8$ $20,5 / (f + 1)$		
		M	$f \leq 37,4$ $49 / (f + 56)$	$f \leq 16,3$ $99 / (f + 56)$	2,6	5,0
			$f > 37,4$ $20,5 / (f + 1)$	$f > 16,3$ $20,5 / (f + 1)$		
		S	$f \leq 30,6$ $56 / (f + 56)$	$f \leq 13,9$ $112 / (f + 56)$	3,0	5,6
			$f > 30,6$ $20,5 / (f + 1)$	$f > 13,9$ $20,5 / (f + 1)$		
		I	$f \leq 22,3$ $68 / (f + 56)$	$f \leq 10,5$ $136 / (f + 56)$	3,7	6,9
			$f > 22,3$ $20,5 / (f + 1)$	$f > 10,5$ $20,5 / (f + 1)$		

*Table D38-3 Modified characteristic capacity timber beam to timber beam – 2 Angle Brackets, Nailing pattern 1*

2 Angle Brackets E8/2.5 per connection			Modified characteristic capacities (kN)							
Nailing pattern 1		Load duration	$R_{1,k} \times k_{mod}$				$R_{2/3,k} \times k_{mod}$			
Number of Fasteners			CNA4,0x35	CNA4,0x40	CNA4,0x50	CNA4,0x60	CNA4,0x35	CNA4,0x40	CNA4,0x50	CNA4,0x60
Flange A	Flange B									
6	4	P	1,2	1,4	2,3	2,5	2,2	2,4	4,0	4,3
		L	1,7	2,0	3,2	3,4	3,0	3,3	5,5	6,0
		M	1,9	2,2	3,7	3,9	3,4	3,8	6,3	6,8
		S	2,2	2,5	4,1	4,4	3,9	4,2	7,1	7,7
		I	2,6	3,1	5,1	5,4	4,7	5,2	8,7	9,4

*Table D38-4 Modified characteristic capacity timber beam to timber beam – 2 Angle Brackets E8/2,5 Nailing pattern 2*

2 Angle Brackets E8/2.5 per connection			Modified characteristic capacities (kN)							
Nailing pattern 2		Load duration	$R_{1,k} \times k_{mod}$				$R_{2/3,k} \times k_{mod}$			
Number of Fasteners			CNA4,0x35	CNA4,0x40	CNA4,0x50	CNA4,0x60	CNA4,0x35	CNA4,0x40	CNA4,0x50	CNA4,0x60
Flange A	Flange B									
13	6	P	2,8	3,2	3,6	3,8	5,0	5,5	6,7	7,1
		L	3,9	4,4	5,0	5,3	7,0	7,6	9,3	9,9
		M	4,4	5,0	5,8	6,1	8,0	8,7	10,6	11,4
		S	5,0	5,7	6,5	6,8	9,0	9,8	12,0	12,8
		I	6,1	6,9	7,9	8,4	11,0	12,0	14,6	15,6

*Table D38-5 Modified characteristic capacity timber column to timber beam – 1 Angle Bracket, Nailing pattern 2 & 3*

1 Angle Bracket E8/2.5 per connection		Modified characteristic capacity (kN)				
Number of fasteners		Load duration	$R_{1,k} \times k_{mod}$ Nailing pattern 3		$R_{2/3,k} \times k_{mod}$ Nailing pattern 2	
Flange A	Flange B		4,0x35	4,0x60	4,0x35	4,0x60
For $R_1$ : 10 For $R_{2/3}$ : 13	6	P	$f \leq 65,9$ $37 / (f + 56)$	$f \leq 25$ $74 / (f + 56)$	1,8	3,7
			$f > 65,9$ $20,5 / (f + 1)$	$f > 25$ $20,5 / (f + 1)$		
		L	$f \leq 47,8$ $43 / (f + 56)$	$f \leq 19,8$ $87 / (f + 56)$	2,1	4,3
			$f > 47,8$ $20,5 / (f + 1)$	$f > 19,8$ $20,5 / (f + 1)$		
		M	$f \leq 37,4$ $49 / (f + 56)$	$f \leq 16,3$ $99 / (f + 56)$	2,5	4,8
			$f > 37,4$ $20,5 / (f + 1)$	$f > 16,3$ $20,5 / (f + 1)$		
		S	$f \leq 30,6$ $56 / (f + 56)$	$f \leq 13,9$ $112 / (f + 56)$	2,8	5,5
			$f > 30,6$ $20,5 / (f + 1)$	$f > 13,9$ $20,5 / (f + 1)$		
		I	$f \leq 22,3$ $68 / (f + 56)$	$f \leq 10,5$ $136 / (f + 56)$	3,4	6,7
			$f > 22,3$ $20,5 / (f + 1)$	$f > 10,5$ $20,5 / (f + 1)$		

**Table D38-6** Modified characteristic capacity timber column to timber beam – 2 Angle Brackets Nailing pattern 2 & 3

2 Angle Brackets E8/2.5 per connection		Modified characteristic capacities (kN)				
Number of Fasteners		Load duration	$R_{1,k} \times k_{mod}$		$R_{2/3,k} \times k_{mod}$	
			Nailing pattern 3		Nailing pattern 2	
Flange A	Flange B		CNA4,0x35	CNA4,0x60	CNA4,0x35	CNA4,0x60
For $R_1$ : 10 For $R_{2/3}$ : 13	6	P	2,5	5,0	3,7	7,3
		L	2,9	5,8	4,3	8,5
		M	3,3	6,7	4,9	9,8
		S	3,7	7,5	5,6	10,9
		I	4,5	9,2	6,8	13,4

**Table D38-7** Modified characteristic capacity timber beam to rigid support – 1 Angle Bracket, Nailing pattern 4

1 Angle Bracket E8/2.5 per connection		Modified characteristic capacity (kN)								
Nailing pattern 4		Load duration	$R_{1,k} \times k_{mod}$				$R_{2/3,k} \times k_{mod}$ 1)			
Number of fasteners			4,0x35	4,0x40	4,0x50	4,0x60	4,0x35	4,0x40	4,0x50	4,0x60
Flange A	Flange B									
13	1 x Ø10 Bolt	P	19,2 / (f + 28)				0,6	0,7	1,1	1,2
		L					0,7	0,8	1,3	1,4
		M					0,8	0,9	1,4	1,6
		S					0,9	1,0	1,6	1,8
		I					1,1	1,2	2,0	2,2

Note: 1) only available for connection in a round hole, not with the version with oblong hole.

Bolt factor	for $F_1$	for $F_{2/3}$
$k_{ax}$	$(f + 41,5) / 8$	1,87
$k_{lat}$	-	1,00

For each bolt it's needed to check:  $R_{bolt,d,lateral} \geq k_{lat} \times F_{i,d}$ ;  $R_{bolt,d,axial} \geq k_{ax} \times F_{i,d}$ ; and also the combination



**Table D38-8** Modified characteristic capacity timber beam to rigid support – 2 Angle Brackets, Nailing pattern 4

2 Angle Brackets E8/2.5 per connection			Modified characteristic capacities (kN)							
Nailing pattern 4		Load duration	$R_{1,k} \times k_{mod}$				$R_{2/3,k} \times k_{mod}$ 1)			
Number of Fasteners			CNA4,0x35	CNA4,0x40	CNA4,0x50	CNA4,0x60	CNA4,0x35	CNA4,0x40	CNA4,0x50	CNA4,0x60
Flange A	Flange B									
13	1 x Ø10 Bolt	P	6,4	6,4	6,4	6,4	2,9	3,3	4,1	4,5
		L	8,9	8,9	8,9	8,9	4,0	4,6	5,7	6,3
		M	10,2	10,2	10,2	10,2	4,6	5,2	6,5	7,2
		S	11,4	11,4	11,4	11,4	5,1	5,9	7,3	8,1
		I	14,0	14,0	14,0	14,0	6,3	7,2	8,9	9,9

**Note:** 1) only available for connection in a round hole, not with the version with oblong hole.

Bolt factor	for $F_1$	for $F_{2/3}$
$k_{ax}$	1,02	0,93
$k_{lat}$	-	0,50

For each bolt it's needed to check:  $R_{bolt,d,lateral} \geq k_{lat} \times F_{i,d}$  ;  $R_{bolt,d,axial} \geq k_{ax} \times F_{i,d}$  ; and also the combination

Table D38-9 Modified characteristic capacity timber column to rigid support – 1 Angle Bracket, Nailing pattern 4 &amp; 5

1 Angle Bracket E8/2.5 per connection		Modified characteristic capacity (kN)				
Number of fasteners		Load duration	$R_{1,k} \times k_{mod}$ Nailing pattern 5		$R_{2/3,k} \times k_{mod}$ Nailing pattern 4	
Flange A	Flange B		4,0x35	4,0x60	4,0x35	4,0x60
For $R_1$ : 10 For $R_{2/3}$ : 13	1 x $\varnothing 10$ Bolt	P	$f \leq 23,4$ $8 / f$	$19,2 / (f + 28)$	0,6	1,2
			$f > 23,4$ $19,2 / (f + 28)$			
		L	$f \leq 31,9$ $10 / f$		0,7	1,4
			$f > 31,9$ $19,2 / (f + 28)$			
		M	$f \leq 43,6$ $11 / f$		0,8	1,7
			$f > 43,6$ $19,2 / (f + 28)$			
		S	$f \leq 61,2$ $13 / f$		0,9	1,9
			$f > 61,2$ $19,2 / (f + 28)$			
		I	$f \leq 148$ $16,2 / f$		1,1	2,2
			$f > 148$ $19,2 / (f + 28)$			

Bolt factor	for $F_1$	for $F_{2/3}$
$k_{ax}$	$(f + 41,5) / 8$	1,87
$k_{lat}$	-	1,00

For each bolt it's needed to check:  $R_{bolt,d,lateral} \geq k_{lat} \times F_{i,d}$  ;  $R_{bolt,d,axial} \geq k_{ax} \times F_{i,d}$  ; and also the combination

*Table D38-10 Modified characteristic capacity timber column to rigid support – 2 Angle Brackets Nailing pattern 4 & 5*

2 Angle Brackets E8/2.5 per connection		Modified characteristic capacities (kN)				
Number of Fasteners		Load duration	R <sub>1,k</sub> x k <sub>mod</sub> Nailing pattern 5		R <sub>2/3,k</sub> x k <sub>mod</sub> Nailing pattern 4	
Flange A	Flange B		CNA4,0x35	CNA4,0x60	CNA4,0x35	CNA4,0x60
For R <sub>1</sub> : 10 For R <sub>2/3</sub> : 13	1 x Ø10 Bolt	P	2,0	4,0	1,1	2,5
		L	2,3	4,6	1,4	2,8
		M	2,6	5,3	1,6	3,3
		S	3,0	6,0	1,8	3,7
		I	3,7	7,3	2,2	4,6

Bolt factor	for F <sub>1</sub>	for F <sub>2/3</sub>
k <sub>ax</sub>	1,02	0,93
k <sub>lat</sub>	-	0,50

For each bolt it's needed to check:  $R_{\text{bolt,d,lateral}} \geq k_{\text{lat}} \times F_{\text{i,d}}$  ;  $R_{\text{bolt,d,axial}} \geq k_{\text{ax}} \times F_{\text{i,d}}$  ; and also the combination

General note to all capacity tables:

- b, e and f are in mm.
- Wane may not occur under the angle bracket.

## Annex D39 – E14/2

### Product Name:

Product Name	Material reference acc. to clause II-1	Alternative product names
E14/2	Steel ref. 1	-
E14/2S	Steel ref. 2	-
E14/2S2	Steel ref. 3	-

### Connector Size Range:

Model no.	Dimensions [mm]				Holes flange A		Holes flange B	
	A	B	C	Thickness	Ø5	Ø13	Ø5	Ø13
E14/2	82	52	75	2,0	8	1	4	1

### Drawing:

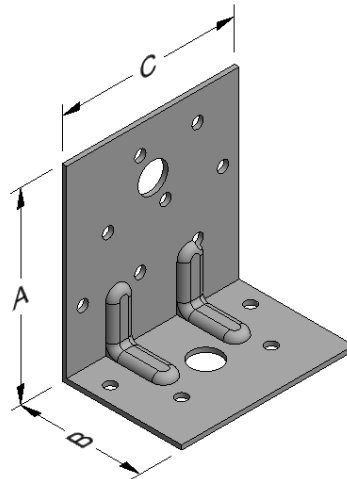

### Nailing pattern:

Nailing pattern 1

Nailing pattern 2

Flange A:

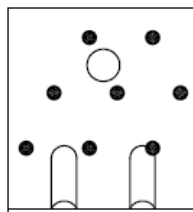
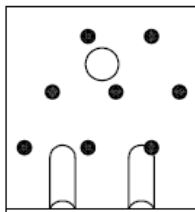

Flange B:

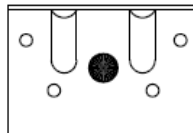
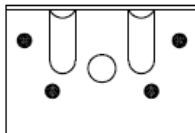

Beam to beam  
Maximum nailing

Beam (A) to  
rigid support (B)

Table D39-1 Modified characteristic capacity timber beam to timber beam – 1 Angle Bracket, Nailing pattern 1

1 Angle Bracket E14/2 per connection		Modified characteristic capacity (kN)				
Nailing pattern 1		Load duration	$R_{1,k} \times k_{mod}$		$R_{2/3,k} \times k_{mod}$	
Number of fasteners			4,0x35	4,0x60	4,0x35	4,0x60
Flange A	Flange B					
4	8	P	$f \leq 65,3$ $20 / (f + 39)$	$f \leq 21,6$ $40 / (f + 39)$	1,6	2,8
			$f > 65,3$ $13,1 / (f + 1)$	$f > 21,6$ $13,1 / (f + 1)$		
		L	$f \leq 44,5$ $23 / (f + 39)$	$f \leq 16,9$ $47 / (f + 39)$	1,8	3,4
			$f > 44,5$ $13,1 / (f + 1)$	$f > 16,9$ $13,1 / (f + 1)$		
		M	$f \leq 33,6$ $27 / (f + 39)$	$f \leq 13,8$ $54 / (f + 39)$	2,1	3,8
			$f > 33,6$ $13,1 / (f + 1)$	$f > 13,8$ $13,1 / (f + 1)$		
		S	$f \leq 27$ $31 / (f + 39)$	$f \leq 11,6$ $61 / (f + 39)$	2,4	4,4
			$f > 27$ $13,1 / (f + 1)$	$f > 11,6$ $13,1 / (f + 1)$		
		I	$f \leq 19,2$ $37 / (f + 39)$	$f \leq 8,7$ $75 / (f + 39)$	2,9	5,3
			$f > 19,2$ $13,1 / (f + 1)$	$f > 8,7$ $13,1 / (f + 1)$		

*Table D39-2 Modified characteristic capacity timber beam to timber beam – 2 Angle Brackets, Nailing pattern 1*

2 Angle Brackets E14/2 per connection		Modified characteristic capacities (kN)				
Nailing pattern 1		Load duration	R <sub>1,k</sub> x k <sub>mod</sub>		R <sub>2/3,k</sub> x k <sub>mod</sub>	
Number of Fasteners			CNA4,0x35	CNA4,0x60	CNA4,0x35	CNA4,0x60
Flange A	Flange B					
4	8	P	2,5	5,0	3,2	5,8
		L	2,9	5,8	3,7	6,8
		M	3,3	6,7	4,3	7,7
		S	3,7	7,5	4,8	8,7
		I	4,5	9,2	5,9	10,7

*Table D39-3 Modified characteristic capacity timber beam to rigid support – 1 Angle Bracket E14/2 Nailing pattern 2*

1 Angle Bracket E14/2 per connection		Modified characteristic capacity (kN)				
Nailing pattern 2		Load duration	R <sub>1,k</sub> x k <sub>mod</sub>		R <sub>2/3,k</sub> x k <sub>mod</sub>	
Number of fasteners			4,0x35	4,0x60	4,0x35	4,0x60
Flange A	Flange B					
8	1 x Ø12 Bolt	P	Min of: 26,5 / (f + 17) 11,3 / f		1,0	2,0
		L			1,1	2,4
		M			1,4	2,8
		S			1,5	3,1
		I			1,8	8,0

Bolt factor	for F <sub>1</sub>	for F <sub>2/3</sub>
k <sub>ax</sub>	(f + 33) / 9	1,04
k <sub>lat</sub>	-	1,00

For each bolt it's needed to check:  $R_{bolt,d,lateral} \geq k_{lat} \times F_{i,d}$  ;  $R_{bolt,d,axial} \geq k_{ax} \times F_{i,d}$ ; and also the combination

**Table D39-4** Modified characteristic capacity timber beam to rigid support – 2 Angle Brackets, Nailing pattern 2

2 Angle Brackets E14/2 per connection		Modified characteristic capacities (kN)				
Nailing pattern 2		Load duration	$R_{1,k} \times k_{mod}$		$R_{2/3,k} \times k_{mod}$	
Number of Fasteners			CNA4,0x35	CNA4,0x60	CNA4,0x35	CNA4,0x60
Flange A	Flange B					
8	1 x Ø12 Bolt	P	2,1	4,2	2,0	4,2
		L	2,5	4,9	2,3	4,8
		M	2,8	5,6	2,7	5,5
		S	3,2	6,4	3,1	6,3
		I	3,9	6,9	3,7	7,6

Bolt factor	for $F_1$	for $F_{2/3}$
$k_{ax}$	0,99	0,52
$k_{lat}$	-	0,50

For each bolt it's needed to check:  $R_{bolt,d,lateral} \geq k_{lat} \times F_{i,d}$  ;  $R_{bolt,d,axial} \geq k_{ax} \times F_{i,d}$  ; and also the combination

General note to all capacity tables:

- b, e and f are in mm.
- Wane may not occur under the angle bracket.

## Annex D40 – E17/2

### Product Name:

Product Name	Material reference acc. to clause II-1	Alternative product names
E17/2	Steel ref. 1	-
E17/2S	Steel ref. 2	-
E17/2S2	Steel ref. 3	-

### Connector Size Range:

Model no.	Dimensions [mm]				Holes flange A		Holes flange B	
	A	B	C	Thickness	Ø5	Ø13	Ø5	Ø13
E17/2	152	52	75	2,0	15	2	4	1

### Drawing:

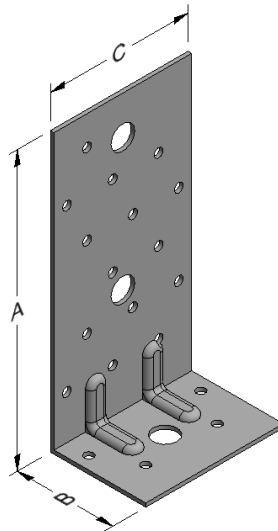

### Nailing pattern:

	Nailing pattern 1	Nailing pattern 2	Nailing pattern 3	Nailing pattern 4	Nailing pattern 5
Flange A:					
Flange B:					
	Beam to beam Minimum nailing	Beam to beam Maximum nailing	Column (A) to beam (B)	Beam (A) to rigid support (B)	Column (A) to rigid support (B)



*Table D40-1 Modified characteristic capacity timber beam to timber beam – 1 Angle Bracket, Nailing pattern 1*

1 Angle Bracket E17/2 per connection		Modified characteristic capacity (kN)				
Nailing pattern 1		Load duration	$R_{1,k} \times k_{mod}$		$R_{2/3,k} \times k_{mod}$	
Number of fasteners			4,0x35	4,0x60	4,0x35	4,0x60
Flange A	Flange B					
6	4	P	$f \leq 65,3$ $20 / (f + 39)$	$f \leq 21,6$ $40 / (f + 39)$	1,2	2,3
			$f > 65,3$ $13,1 / (f + 1)$	$f > 21,6$ $13,1 / (f + 1)$		
		L	$f \leq 44,5$ $23 / (f + 39)$	$f \leq 16,9$ $47 / (f + 39)$	1,4	2,7
			$f > 44,5$ $13,1 / (f + 1)$	$f > 16,9$ $13,1 / (f + 1)$		
		M	$f \leq 33,6$ $27 / (f + 39)$	$f \leq 13,8$ $54 / (f + 39)$	1,7	3,1
			$f > 33,6$ $13,1 / (f + 1)$	$f > 13,8$ $13,1 / (f + 1)$		
		S	$f \leq 27$ $31 / (f + 39)$	$f \leq 11,6$ $61 / (f + 39)$	1,9	3,5
			$f > 27$ $13,1 / (f + 1)$	$f > 11,6$ $13,1 / (f + 1)$		
		I	$f \leq 19,2$ $37 / (f + 39)$	$f \leq 8,7$ $75 / (f + 39)$	2,3	4,3
			$f > 19,2$ $13,1 / (f + 1)$	$f > 8,7$ $13,1 / (f + 1)$		

Table D40-2 Modified characteristic capacity timber beam to timber beam – 1 Angle Bracket, Nailing pattern 2

1 Angle Bracket E17/2 per connection		Modified characteristic capacity (kN)				
Nailing pattern 2		Load duration	$R_{1,k} \times k_{mod}$		$R_{2/3,k} \times k_{mod}$	
Number of fasteners			4,0x35	4,0x60	4,0x35	4,0x60
Flange A	Flange B					
15	4	P	$f \leq 65,3$ $20 / (f + 39)$	$f \leq 21,6$ $40 / (f + 39)$	2,1	3,6
			$f > 65,3$ $13,1 / (f + 1)$	$f > 21,6$ $13,1 / (f + 1)$		
		L	$f \leq 44,5$ $23 / (f + 39)$	$f \leq 16,9$ $47 / (f + 39)$	2,4	4,1
			$f > 44,5$ $13,1 / (f + 1)$	$f > 16,9$ $13,1 / (f + 1)$		
		M	$f \leq 33,6$ $37 / (f + 39)$	$f \leq 13,8$ $54 / (f + 39)$	2,8	4,7
			$f > 33,6$ $13,1 / (f + 1)$	$f > 13,8$ $13,1 / (f + 1)$		
		S	$f \leq 27$ $31 / (f + 39)$	$f \leq 11,6$ $61 / (f + 39)$	3,1	5,3
			$f > 27$ $13,1 / (f + 1)$	$f > 11,6$ $13,1 / (f + 1)$		
		I	$f \leq 19,2$ $37 / (f + 39)$	$f \leq 8,7$ $75 / (f + 39)$	3,8	6,5
			$f > 19,2$ $13,1 / (f + 1)$	$f > 8,7$ $13,1 / (f + 1)$		

*Table D40-3 Modified characteristic capacity timber beam to timber beam – 2 Angle Brackets, Nailing pattern 1*

2 Angle Brackets E17/2 per connection			Modified characteristic capacities (kN)							
Nailing pattern 1		Load duration	$R_{1,k} \times k_{mod}$				$R_{2/3,k} \times k_{mod}$			
Number of Fasteners			CNA4,0x35	CNA4,0x40	CNA4,0x50	CNA4,0x60	CNA4,0x35	CNA4,0x40	CNA4,0x50	CNA4,0x60
Flange A	Flange B									
6	4	P	2,1	2,4	3,8	4,2	2,2	2,4	3,7	3,9
		L	2,9	3,3	5,3	5,8	3,0	3,3	5,1	5,5
		M	3,3	3,8	6,0	6,6	3,4	3,8	5,8	6,2
		S	3,7	4,2	6,8	7,5	3,9	4,2	6,6	7,0
		I	4,5	5,2	8,3	9,1	4,7	5,2	8,0	8,6

*Table D40-4 Modified characteristic capacity timber beam to timber beam – 2 Angle Brackets, Nailing pattern 2*

2 Angle Brackets E17/2 per connection			Modified characteristic capacities (kN)							
Nailing pattern 2		Load duration	$R_{1,k} \times k_{mod}$				$R_{2/3,k} \times k_{mod}$			
Number of Fasteners			CNA4,0x35	CNA4,0x40	CNA4,0x50	CNA4,0x60	CNA4,0x35	CNA4,0x40	CNA4,0x50	CNA4,0x60
Flange A	Flange B									
15	4	P	2,5	2,8	3,4	3,7	4,1	4,5	5,5	5,8
		L	3,4	3,9	4,7	5,2	5,7	6,3	7,6	8,1
		M	3,9	4,5	5,4	5,9	6,6	7,2	8,7	9,3
		S	4,4	5,0	6,0	6,7	7,4	8,1	9,8	10,4
		I	5,4	6,2	7,4	8,1	9,0	9,9	12,0	12,8

Table D40-5 Modified characteristic capacity timber column to timber beam – 1 Angle Bracket, Nailing pattern 3

1 Angle Bracket E17/2 per connection		Modified characteristic capacity (kN)				
Nailing pattern 3		Load duration	$R_{1,k} \times k_{mod}$		$R_{2/3,k} \times k_{mod}$	
Number of fasteners			4,0x35	4,0x60	4,0x35	4,0x60
Flange A	Flange B					
12	4	P	$f \leq 65,3$ $21 / (f + 39)$	$f \leq 21,6$ $40 / (f + 39)$	2,0	3,4
			$f > 65,3$ $13,1 / (f + 1)$	$f > 21,6$ $13,1 / (f + 1)$		
		L	$f \leq 44,5$ $23 / (f + 39)$	$f \leq 16,9$ $47 / (f + 39)$	2,3	4
			$f > 44,5$ $13,1 / (f + 1)$	$f > 16,9$ $13,1 / (f + 1)$		
		M	$f \leq 33,6$ $27 / (f + 39)$	$f \leq 13,8$ $54 / (f + 39)$	2,6	4,6
			$f > 33,6$ $13,1 / (f + 1)$	$f > 13,8$ $13,1 / (f + 1)$		
		S	$f \leq 27$ $31 / (f + 39)$	$f \leq 11,6$ $61 / (f + 39)$	3,0	5,1
			$f > 27$ $13,1 / (f + 1)$	$f > 11,6$ $13,1 / (f + 1)$		
		I	$f \leq 19,2$ $37 / (f + 39)$	$f \leq 8,7$ $75 / (f + 39)$	3,7	6,3
			$f > 19,2$ $13,1 / (f + 1)$	$f > 8,7$ $13,1 / (f + 1)$		

*Table D40-6 Modified characteristic capacity timber column to timber beam – 2 Angle Brackets, Nailing pattern 3*

2 Angle Brackets E17/2 per connection		Modified characteristic capacities (kN)				
Nailing pattern 3		Load duration	$R_{1,k} \times k_{mod}$		$R_{2/3,k} \times k_{mod}$	
Number of Fasteners			CNA4,0x35	CNA4,0x60	CNA4,0x35	CNA4,0x60
Flange A	Flange B					
12	4	P	2,5	5,0	4,0	6,8
		L	2,9	5,8	4,6	8,0
		M	3,3	6,7	5,4	9,1
		S	3,7	7,5	6,0	10,2
		I	4,5	9,2	7,4	12,6

*Table D40-7 Modified characteristic capacity timber beam to rigid support – 1 Angle Bracket, Nailing pattern 4*

1 Angle Bracket E17/2 per connection		Modified characteristic capacity (kN)								
Nailing pattern 4		Load duration	$R_{1,k} \times k_{mod}$				$R_{2/3,k} \times k_{mod}$			
Number of fasteners			4,0x35	4,0x40	4,0x50	4,0x60	4,0x35	4,0x40	4,0x50	4,0x60
Flange A	Flange B									
15	1 x Ø10 Bolt	P	Min of: 26,5 / (f + 17)  11,3 / f				1,0	1,2	1,9	2,1
		L					1,2	1,4	2,2	2,5
		M					1,4	1,6	2,5	2,8
		S					1,5	1,8	2,8	3,2
		I					1,9	2,2	3,4	3,9

Bolt factor	for $F_1$	for $F_{2/3}$
$k_{ax}$	$(f + 33) / 9$	1,82
$k_{lat}$	-	1,00

For each bolt it's needed to check:  $R_{bolt,d,lateral} \geq k_{lat} \times F_{i,d}$  ;  $R_{bolt,d,axial} \geq k_{ax} \times F_{i,d}$  ; and also the combination

Table D40-8 Modified characteristic capacity timber beam to rigid support – 2 Angle Brackets, Nailing pattern 4

2 Angle Brackets E17/2 per connection		Modified characteristic capacity (kN)								
Nailing pattern 4		Load duration	$R_{1,k} \times k_{mod}$				$R_{2/3,k} \times k_{mod}$			
Number of fasteners			4,0x35	4,0x40	4,0x50	4,0x60	4,0x35	4,0x40	4,0x50	4,0x60
Flange A	Flange B									
15	1 x Ø10 Bolt	P	15,2				3,5	4,0	5,0	5,6
		L					4,1	4,6	5,8	6,6
		M					4,6	5,3	6,6	7,5
		S					5,2	5,9	7,5	8,5
		I					6,4	7,3	9,1	10,3

Bolt factor	for $F_1$	for $F_{2/3}$
$k_{ax}$	0,99	0,91
$k_{lat}$	-	0,50

For each bolt it's needed to check:  $R_{bolt,d,lateral} \geq k_{lat} \times F_{i,d}$  ;  $R_{bolt,d,axial} \geq k_{ax} \times F_{i,d}$ ; and also the combination

Table D40-9 Modified characteristic capacity timber column to rigid support – 1 Angle Bracket, Nailing pattern 5

1 Angle Bracket E17/2 per connection		Modified characteristic capacity (kN)				
Nailing pattern 5		Load duration	$R_{1,k} \times k_{mod}$		$R_{2/3,k} \times k_{mod}$	
Number of fasteners			4,0x35	4,0x60	4,0x35	4,0x60
Flange A	Flange B					
12	1 x Ø10 Bolt	P	Min of: 26,5 / (f + 17) 11,3 / f		1,0	1,7
		L			1,2	1,9
		M			1,4	2,2
		S			1,5	2,5
		I			1,9	3,1

Bolt factor	for $F_1$	for $F_{2/3}$
$k_{ax}$	(f + 33) / 9	1,82
$k_{lat}$	-	1,00

For each bolt it's needed to check:  $R_{bolt,d,lateral} \geq k_{lat} \times F_{i,d}$  ;  $R_{bolt,d,axial} \geq k_{ax} \times F_{i,d}$ ; and also the combination

*Table D40-10 Modified characteristic capacity timber column to rigid support – 2 Angle Brackets, Nailing pattern 5*

2 Angle Brackets E17/2 per connection		Modified characteristic capacities (kN)				
Nailing pattern 5		Load duration	$R_{1,k} \times k_{mod}$		$R_{2/3,k} \times k_{mod}$	
Number of Fasteners			CNA4,0x35	CNA4,0x60	CNA4,0x35	CNA4,0x60
Flange A	Flange B					
12	1 x Ø10 Bolt	P	6,1	11,7	2,0	3,4
		L	7,1	13,6	2,4	3,9
		M	8,2	14,2	2,8	4,5
		S	9,2	14,2	3,1	5,1
		I	11,2	14,2	3,8	6,2

Bolt factor	for $F_1$	for $F_{2/3}$
$k_{ax}$	0,99	0,91
$k_{lat}$	-	0,50

For each bolt it's needed to check:  $R_{bolt,d,lateral} \geq k_{lat} \times F_{i,d}$  ;  $R_{bolt,d,axial} \geq k_{ax} \times F_{i,d}$  ; and also the combination

General notes to all capacity tables:

- b, e and f are in mm.
- Wane may not occur under the angle bracket.

## Annex D41 – E18/2,5

### Product Name:

Product Name	Material reference acc. to clause II-1	Alternative product names
E18/2,5	Steel ref. 1	-
E18/2,5S	Steel ref. 2	-
E18/2,5S2	Steel ref. 3	-

### Connector Size Range:

Model no.	Dimensions [mm]				Holes flange A		Holes flange B	
	A	B	C	Thickness	Ø5	Ø13	Ø5	Ø13
E18/2,5	152,5	52,5	75	2,5	15	2	4	1

### Drawing:

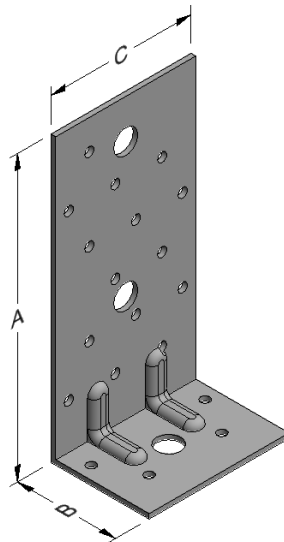

### Nailing pattern:

Nailing pattern 1

Nailing pattern 2

Nailing pattern 3

Nailing pattern 4

Nailing pattern 5

Flange A:

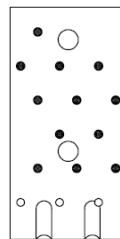
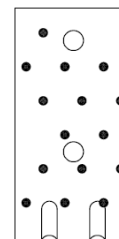
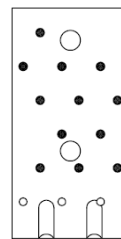
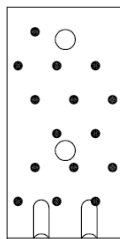
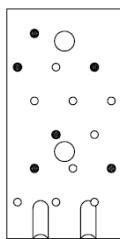

Flange B:

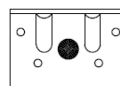
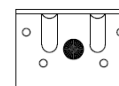
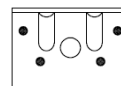
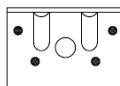
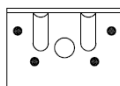

Beam to beam  
Minimum nailing

Beam to beam  
Maximum nailing

Column (A) to  
beam (B)

Beam (A) to  
rigid support (B)

Column (A) to  
rigid support (B)



*Table D41-1 Modified characteristic capacity timber beam to timber beam – 1 Angle Bracket, Nailing pattern 1*

1 Angle Bracket E18/2.5 per connection		Modified characteristic capacity (kN)				
Nailing pattern 1		Load duration	$R_{1,k} \times k_{mod}$		$R_{2/3,k} \times k_{mod}$	
Number of fasteners			4,0x35	4,0x60	4,0x35	4,0x60
Flange A	Flange B					
6	4	P	$f \leq 5721$ $20 / (f + 39)$	$f \leq 52,3$ $40 / (f + 39)$	1,5	2,7
			$f > 5721$ $20,5 / (f + 1)$	$f > 52,3$ $20,5 / (f + 1)$		
		L	$f \leq 218$ $23 / (f + 39)$	$f \leq 37$ $47 / (f + 39)$	1,7	3,1
			$f > 218$ $20,5 / (f + 1)$	$f > 37$ $20,5 / (f + 1)$		
		M	$f \leq 110,5$ $27 / (f + 39)$	$f \leq 28,5$ $54 / (f + 39)$	2	3,5
			$f > 110,5$ $20,5 / (f + 1)$	$f > 28,5$ $20,5 / (f + 1)$		
		S	$f \leq 73,7$ $31 / (f + 39)$	$f \leq 23,1$ $61 / (f + 39)$	2,3	3,9
			$f > 73,7$ $20,5 / (f + 1)$	$f > 23,1$ $20,5 / (f + 1)$		
		I	$f \leq 44$ $37 / (f + 39)$	$f \leq 16,6$ $75 / (f + 39)$	2,8	4,8
			$f > 44$ $20,5 / (f + 1)$	$f > 16,6$ $20,5 / (f + 1)$		

Table D41-2 Modified characteristic capacity timber beam to timber beam – 1 Angle Bracket, Nailing pattern 2

1 Angle Bracket E18/2.5 per connection		Modified characteristic capacity (kN)				
Nailing pattern 2		Load duration	$R_{1,k} \times k_{mod}$		$R_{2/3,k} \times k_{mod}$	
Number of fasteners			4,0x35	4,0x60	4,0x35	4,0x60
Flange A	Flange B					
15	4	P	$f \leq 5721$ $20 / (f + 39)$	$f \leq 52,3$ $40 / (f + 39)$	2,4	4,3
			$f > 5721$ $20,5 / (f + 1)$	$f > 52,3$ $20,5 / (f + 1)$		
		L	$f \leq 218$ $23 / (f + 39)$	$f \leq 37$ $47 / (f + 39)$	2,8	5
			$f > 218$ $20,5 / (f + 1)$	$f > 37$ $20,5 / (f + 1)$		
		M	$f \leq 110,5$ $37 / (f + 39)$	$f \leq 28,5$ $54 / (f + 39)$	3,2	5,8
			$f > 110,5$ $20,5 / (f + 1)$	$f > 28,5$ $20,5 / (f + 1)$		
		S	$f \leq 73,7$ $31 / (f + 39)$	$f \leq 23,1$ $61 / (f + 39)$	3,7	6,5
			$f > 73,7$ $20,5 / (f + 1)$	$f > 23,1$ $20,5 / (f + 1)$		
		I	$f \leq 44$ $37 / (f + 39)$	$f \leq 16,6$ $75 / (f + 39)$	4,5	8,0
			$f > 44$ $20,5 / (f + 1)$	$f > 16,6$ $20,5 / (f + 1)$		

*Table D41-3 Modified characteristic capacity timber beam to timber beam – 2 Angle Brackets, Nailing pattern 1*

2 Angle Brackets E18/2.5 per connection			Modified characteristic capacities (kN)							
Nailing pattern 1		Load duration	$R_{1,k} \times k_{mod}$				$R_{2/3,k} \times k_{mod}$			
Number of Fasteners			CNA4,0x35	CNA4,0x40	CNA4,0x50	CNA4,0x60	CNA4,0x35	CNA4,0x40	CNA4,0x50	CNA4,0x60
Flange A	Flange B									
6	4	P	2,1	2,4	3,8	4,2	2,5	2,7	4,1	4,5
		L	2,9	3,4	5,3	5,8	3,5	3,8	5,7	6,2
		M	3,3	3,8	6,0	6,6	4,0	4,3	6,6	7,1
		S	3,7	4,3	6,8	7,5	4,5	4,9	7,4	8,0
		I	4,5	5,3	8,3	9,1	5,5	5,9	9,0	9,8

*Table D41-4 Modified characteristic capacity timber beam to timber beam – 2 Angle Brackets, Nailing pattern 2*

2 Angle Brackets E18/2.5 per connection			Modified characteristic capacities (kN)							
Nailing pattern 2		Load duration	$R_{1,k} \times k_{mod}$				$R_{2/3,k} \times k_{mod}$			
Number of Fasteners			CNA4,0x35	CNA4,0x40	CNA4,0x50	CNA4,0x60	CNA4,0x35	CNA4,0x40	CNA4,0x50	CNA4,0x60
Flange A	Flange B									
15	4	P	2,5	2,8	3,4	3,7	4,1	4,5	5,5	5,8
		L	3,4	3,9	4,7	5,2	5,7	6,2	7,6	8,1
		M	3,9	4,5	5,4	5,9	6,6	7,1	8,7	9,3
		S	4,4	5,0	6,0	6,7	7,4	8,0	9,8	10,4
		I	5,4	6,2	7,4	8,1	9,0	9,8	12,0	12,8

Table D41-5 Modified characteristic capacity timber column to timber beam – 1 Angle Bracket, Nailing pattern 3

1 Angle Bracket E18/2.5 per connection		Modified characteristic capacity (kN)				
Nailing pattern 3		Load duration	$R_{1,k} \times k_{mod}$		$R_{2/3,k} \times k_{mod}$	
Number of fasteners			4,0x35	4,0x60	4,0x35	4,0x60
Flange A	Flange B					
12	4	P	$f \leq 235,5$ $20 / (f + 39)$	$f \leq 37,9$ $40 / (f + 39)$	2,0	3,6
			$f > 235,5$ $17 / (f + 1)$	$f > 37,9$ $17 / (f + 1)$		
		L	$f \leq 106,5$ $23 / (f + 39)$	$f \leq 28$ $47 / (f + 39)$	2,4	4,1
			$f > 106,5$ $17 / (f + 1)$	$f > 28$ $17 / (f + 1)$		
		M	$f \leq 68,5$ $27 / (f + 39)$	$f \leq 22,1$ $54 / (f + 39)$	2,8	4,7
			$f > 68,5$ $17 / (f + 1)$	$f > 22,1$ $17 / (f + 1)$		
		S	$f \leq 50,3$ $31 / (f + 39)$	$f \leq 18,2$ $61 / (f + 39)$	3,1	5,4
			$f > 50,3$ $17 / (f + 1)$	$f > 18,2$ $17 / (f + 1)$		
		I	$f \leq 32,6$ $37 / (f + 39)$	$f \leq 13,3$ $75 / (f + 39)$	3,8	6,5
			$f > 32,6$ $17 / (f + 1)$	$f > 13,3$ $17 / (f + 1)$		

*Table D41-6 Modified characteristic capacity timber column to timber beam – 2 Angle Brackets, Nailing pattern 3*

2 Angle Brackets E18/2.5 per connection		Modified characteristic capacities (kN)				
Nailing pattern 3		Load duration	$R_{1,k} \times k_{mod}$		$R_{2/3,k} \times k_{mod}$	
Number of Fasteners			CNA4,0x35	CNA4,0x60	CNA4,0x35	CNA4,0x60
Flange A	Flange B					
12	4	P	2,5	5,0	4,1	7,1
		L	2,9	5,8	4,8	8,3
		M	3,3	6,7	5,5	9,5
		S	3,7	7,6	6,2	10,7
		I	4,5	9,2	7,7	13,0

*Table D41-7 Modified characteristic capacity timber beam to rigid support – 1 Angle Bracket, Nailing pattern 4*

1 Angle Bracket E18/2.5 per connection		Modified characteristic capacity (kN)								
Nailing pattern 4		Load duration	$R_{1,k} \times k_{mod}$				$R_{2/3,k} \times k_{mod}$			
Number of fasteners			4,0x35	4,0x40	4,0x50	4,0x60	4,0x35	4,0x40	4,0x50	4,0x60
Flange A	Flange B									
15	1 x Ø10 Bolt	P	Min of: 56,6 / (f + 18) 17 / f				1,8	2,1	3,4	3,8
		L					2,1	2,5	3,9	4,4
		M					2,4	2,8	4,5	5,0
		S					2,7	3,2	5,0	5,7
		I					3,3	3,9	6,2	6,9

Bolt factor	for $F_1$	for $F_{2/3}$
$k_{ax}$	$(f + 33,5) / 9$	1,82
$k_{lat}$	-	1,00

For each bolt it's needed to check:  $R_{bolt,d,lateral} \geq k_{lat} \times F_{i,d}$  ;  $R_{bolt,d,axial} \geq k_{ax} \times F_{i,d}$  ; and also the combination

Table D41-8 Modified characteristic capacity timber beam to rigid support – 2 Angle Brackets, Nailing pattern 4

2 Angle Brackets E18/2.5 per connection		Modified characteristic capacity (kN)								
Nailing pattern 4		Load duration	$R_{1,k} \times k_{mod}$				$R_{2/3,k} \times k_{mod}$			
Number of fasteners			4,0x35	4,0x40	4,0x50	4,0x60	4,0x35	4,0x40	4,0x50	4,0x60
Flange A	Flange B									
15	1 x Ø10 Bolt	P	12,3	12,3	12,3	12,3	4,9	5,6	7,0	7,9
		L	14,4	14,4	14,4	14,4	5,7	6,5	8,1	9,2
		M	16,4	16,4	16,4	16,4	6,5	7,4	9,3	10,5
		S	18,5	18,5	18,5	18,5	7,3	8,4	10,4	11,8
		I	22,6	22,6	22,6	22,6	8,9	10,2	12,8	14,4

Bolt factor	for $F_1$	for $F_{2/3}$
$k_{ax}$	0,98	0,91
$k_{lat}$	-	0,50

For each bolt it's needed to check:  $R_{bolt,d,lateral} \geq k_{lat} \times F_{i,d}$  ;  $R_{bolt,d,axial} \geq k_{ax} \times F_{i,d}$ ; and also the combination

Table D41-9 Modified characteristic capacity timber column to rigid support – 1 Angle Bracket, Nailing pattern 5

1 Angle Bracket E18/2.5 per connection		Modified characteristic capacity (kN)				
Nailing pattern 5		Load duration	$R_{1,k} \times k_{mod}$		$R_{2/3,k} \times k_{mod}$	
Number of fasteners			4,0x35	4,0x60	4,0x35	4,0x60
Flange A	Flange B					
12	1 x Ø10 Bolt	P	Min of: 56,5 / (f + 18) 17,7 / f		1,0	2,0
		L			1,1	2,4
		M			1,3	2,8
		S			1,5	3,1
		I			1,8	3,8

Bolt factor	for $F_1$	for $F_{2/3}$
$k_{ax}$	(f + 33,5) / 9	1,82
$k_{lat}$	-	1,00

For each bolt it's needed to check:  $R_{bolt,d,lateral} \geq k_{lat} \times F_{i,d}$  ;  $R_{bolt,d,axial} \geq k_{ax} \times F_{i,d}$ ; and also the combination

*Table D41-10 Modified characteristic capacity timber column to rigid support – 2 Angle Brackets, Nailing pattern 5*

2 Angle Brackets E18/2.5 per connection		Modified characteristic capacities (kN)				
Nailing pattern 5		Load duration	$R_{1,k} \times k_{mod}$		$R_{2/3,k} \times k_{mod}$	
Number of Fasteners			CNA4,0x35	CNA4,0x60	CNA4,0x35	CNA4,0x60
Flange A	Flange B					
12	1 x Ø10 Bolt	P	6,0	11,4	2,0	4,2
		L	7,0	13,4	2,3	4,9
		M	8,0	15,4	2,7	5,6
		S	9,0	17,3	3,1	6,3
		I	11,0	19,3	3,7	7,7

Bolt factor	for $F_1$	for $F_{2/3}$
$k_{ax}$	0,98	0,91
$k_{lat}$	-	0,50

For each bolt it's needed to check:  $R_{bolt,d,lateral} \geq k_{lat} \times F_{i,d}$  ;  $R_{bolt,d,axial} \geq k_{ax} \times F_{i,d}$  ; and also the combination

General notes to all capacity tables:

- b, e and f are in mm.
- Wane may not occur under the angle bracket.

## Annex D42 – E19/3

### Product Name:

Product Name	Material reference acc. to clause II-1	Alternative product names
E19/3	Steel ref. 1	-
E19/3S	Steel ref. 2	-
E19/3S2	Steel ref. 3	-

### Connector Size Range:

Model no.	Dimensions [mm]				Holes flange A		Holes flange B	
	A	B	C	Thickness	Ø5	Ø13	Ø5	Ø13
E19/3	153	53	75	3,0	15	2	4	1

### Drawing:

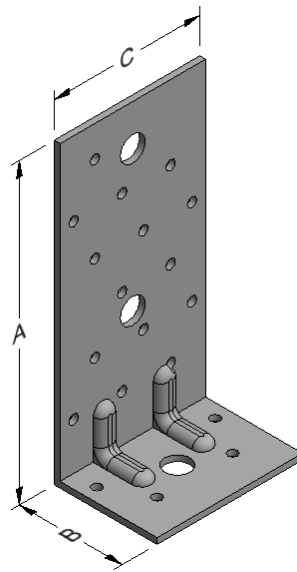

### Nailing pattern:

	Nailing pattern 1	Nailing pattern 2	Nailing pattern 3	Nailing pattern 4	Nailing pattern 5
Flange A:					
Flange B:					
	Beam to beam Minimum nailing	Beam to beam Maximum nailing	Column (A) to beam (B)	Beam (A) to rigid support (B)	Column (A) to rigid support (B)



Table D42-1 Modified characteristic capacity timber beam to timber beam – 1 Angle Bracket, Nailing pattern 1

1 Angle Bracket E19/3 per connection		Modified characteristic capacity (kN)				
Nailing pattern 1		Load duration	$R_{1,k} \times k_{mod}$		$R_{2/3,k} \times k_{mod}$	
Number of fasteners			4,0x35	4,0x60	4,0x35	4,0x60
Flange A	Flange B					
6	4	P	20 / ( f + 40 )	$f \leq 200,6$ 40 / ( f + 40 )	1,5	2,6
				$f > 200,6$ 34,6 / ( f + 2 )		
		L	23 / ( f + 40 )	$f \leq 97,5$ 47 / ( f + 40 )	1,7	3,0
				$f > 97,5$ 34,6 / ( f + 2 )		
		M	27 / ( f + 40 )	$f \leq 64,1$ 54 / ( f + 40 )	2,0	3,5
				$f > 64,1$ 34,6 / ( f + 2 )		
		S	31 / ( f + 40 )	$f \leq 47,5$ 61 / ( f + 40 )	2,3	3,9
				$f > 47,5$ 34,6 / ( f + 2 )		
		I	37 / ( f + 40 )	$f \leq 31,1$ 75 / ( f + 40 )	2,8	4,8
				$f > 31,1$ 34,6 / ( f + 2 )		

Table D42-2 Modified characteristic capacity timber beam to timber beam – 1 Angle Bracket, Nailing pattern 2

1 Angle Bracket E19/3 per connection		Modified characteristic capacity (kN)				
Nailing pattern 2		Load duration	$R_{1,k} \times k_{mod}$		$R_{2/3,k} \times k_{mod}$	
Number of fasteners			4,0x35	4,0x60	4,0x35	4,0x60
Flange A	Flange B					
15	4	P	20 / ( f + 40 )	$f \leq 200,6$ 40 / ( f + 40 )	2,4	4,3
				$f > 200,6$ 34,6 / ( f + 2 )		
		L	23 / ( f + 40 )	$f \leq 97,5$ 47 / ( f + 40 )	2,8	5,0
				$f > 97,5$ 34,6 / ( f + 2 )		
		M	27 / ( f + 40 )	$f \leq 64,1$ 54 / ( f + 40 )	3,2	5,7
$f > 64,1$ 34,6 / ( f + 2 )						
S	31 / ( f + 40 )	$f \leq 47,5$ 61 / ( f + 40 )	3,6	6,4		
		$f > 47,5$ 34,6 / ( f + 2 )				
I	37 / ( f + 40 )	$f \leq 31,1$ 75 / ( f + 40 )	4,4	7,9		
		$f > 31,1$ 34,6 / ( f + 2 )				

*Table D42-3 Modified characteristic capacity timber beam to timber beam – 2 Angle Brackets, Nailing pattern 1*

2 Angle Brackets E19/3 per connection			Modified characteristic capacities (kN)							
Nailing pattern 1		Load duration	$R_{1,k} \times k_{mod}$				$R_{2/3,k} \times k_{mod}$			
Number of Fasteners			CNA4,0x35	CNA4,0x40	CNA4,0x50	CNA4,0x60	CNA4,0x35	CNA4,0x40	CNA4,0x50	CNA4,0x60
Flange A	Flange B									
6	4	P	2,1	2,4	3,8	4,2	2,5	2,7	4,1	4,5
		L	2,9	3,4	5,3	5,8	3,5	3,8	5,7	6,2
		M	3,3	3,8	6,0	6,6	4,0	4,3	6,6	7,1
		S	3,7	4,3	6,8	7,5	4,5	4,9	7,4	8,0
		I	4,5	5,3	8,3	9,1	5,5	5,9	9,0	9,8

*Table D42-4 Modified characteristic capacity timber beam to timber beam – 2 Angle Brackets, Nailing pattern 2*

2 Angle Brackets E19/3 per connection			Modified characteristic capacities (kN)							
Nailing pattern 2		Load duration	$R_{1,k} \times k_{mod}$				$R_{2/3,k} \times k_{mod}$			
Number of Fasteners			CNA4,0x35	CNA4,0x40	CNA4,0x50	CNA4,0x60	CNA4,0x35	CNA4,0x40	CNA4,0x50	CNA4,0x60
Flange A	Flange B									
15	4	P	2,5	2,8	3,4	3,7	4,1	4,4	5,4	5,8
		L	3,4	3,9	4,7	5,2	5,7	6,2	7,5	8,1
		M	3,9	4,5	5,4	5,9	6,5	7,0	8,6	9,2
		S	4,4	5,0	6,0	6,7	7,3	7,9	9,6	10,4
		I	5,4	6,2	7,4	8,1	8,9	9,7	11,8	12,7

Table D42-5 Modified characteristic capacity timber column to timber beam – 1 Angle Bracket, Nailing pattern 3

1 Angle Bracket E19/3 per connection		Modified characteristic capacity (kN)				
Nailing pattern 3		Load duration	$R_{1,k} \times k_{mod}$		$R_{2/3,k} \times k_{mod}$	
Number of fasteners			4,0x35	4,0x60	4,0x35	4,0x60
Flange A	Flange B					
12	4	P	$20 / (f + 40)$	$f \leq 101,5$ $41 / (f + 40)$	1,9	3,4
				$f > 101,5$ $25,5 / (f + 2)$		
		L	$23 / (f + 40)$	$f \leq 62,4$ $47 / (f + 40)$	2,2	4,0
				$f > 62,4$ $25,5 / (f + 2)$		
		M	$23 / (f + 40)$	$f \leq 44,8$ $54 / (f + 40)$	2,6	4,6
				$f > 44,8$ $25,5 / (f + 2)$		
		S	$f \leq 181,9$ $31 / (f + 40)$	$f \leq 34,8$ $61 / (f + 40)$	2,9	5,2
				$f > 181,9$ $25 / (f + 2)$		
		I	$f \leq 78,9$ $37 / (f + 40)$	$f \leq 23,9$ $75 / (f + 40)$	3,5	6,3
				$f > 78,9$ $25 / (f + 2)$		

*Table D42-6 Modified characteristic capacity timber column to timber beam – 2 Angle Brackets, Nailing pattern 3*

2 Angle Brackets E19/3 per connection		Modified characteristic capacities (kN)				
Nailing pattern 3		Load duration	$R_{1,k} \times k_{mod}$		$R_{2/3,k} \times k_{mod}$	
Number of Fasteners			CNA4,0x35	CNA4,0x60	CNA4,0x35	CNA4,0x60
Flange A	Flange B					
12	4	P	2,5	5,0	3,9	6,9
		L	2,9	5,8	4,5	8,1
		M	3,3	6,7	5,1	9,1
		S	3,7	7,5	5,8	10,3
		I	4,5	9,2	7,1	12,7

*Table D42-7 Modified characteristic capacity timber beam to rigid support – 1 Angle Bracket, Nailing pattern 4*

1 Angle Bracket E19/3 per connection		Modified characteristic capacity (kN)								
Nailing pattern 4		Load duration	$R_{1,k} \times k_{mod}$				$R_{2/3,k} \times k_{mod}$			
Number of fasteners			4,0x35	4,0x40	4,0x50	4,0x60	4,0x35	4,0x40	4,0x50	4,0x60
Flange A	Flange B									
15	1 x Ø10 Bolt	P	Min of:  65,6 / (f + 18)  25,5 / f				1,8	2,0	3,3	3,7
		L					2,1	2,4	3,9	4,3
		M					2,4	2,7	4,4	5,0
		S					2,7	3,1	5,0	5,6
		I					3,3	3,7	6,1	6,8

Bolt factor	for $F_1$	for $F_{2/3}$
$k_{ax}$	$(f + 34) / 9$	1,82
$k_{lat}$	-	1,00

For each bolt it's needed to check:  $R_{bolt,d,lateral} \geq k_{lat} \times F_{i,d}$  ;  $R_{bolt,d,axial} \geq k_{ax} \times F_{i,d}$  ; and also the combination

*Table D42-8 Modified characteristic capacity timber beam to rigid support – 2 Angle Brackets, Nailing pattern 4*

2 Angle Brackets E19/3 per connection		Modified characteristic capacity (kN)								
Nailing pattern 4		Load duration	$R_{1,k} \times k_{mod}$				$R_{2/3,k} \times k_{mod}$			
Number of fasteners			4,0x35	4,0x40	4,0x50	4,0x60	4,0x35	4,0x40	4,0x50	4,0x60
Flange A	Flange B									
15	1 x Ø10 Bolt	<b>P</b>	16,9	16,9	16,9	16,9	4,9	5,5	7,0	7,8
		<b>L</b>	19,7	19,7	19,7	19,7	5,7	6,4	8,1	9,1
		<b>M</b>	22,5	22,5	22,5	22,5	6,5	7,4	9,3	10,4
		<b>S</b>	25,3	25,3	25,3	25,3	7,3	8,3	10,4	11,7
		<b>I</b>	30,9	30,9	30,9	30,9	8,9	10,1	12,8	14,3

Bolt factor	for $F_1$	for $F_{2/3}$
$k_{ax}$	0,99	0,91
$k_{lat}$	-	0,50

For each bolt it's needed to check:  $R_{bolt,d,lateral} \geq k_{lat} \times F_{i,d}$  ;  $R_{bolt,d,axial} \geq k_{ax} \times F_{i,d}$  ; and also the combination

Table D42-9 Modified characteristic capacity timber column to rigid support – 1 Angle Bracket, Nailing pattern 5

1 Angle Bracket E19/3 per connection		Modified characteristic capacity (kN)				
Nailing pattern 5		Load duration	$R_{1,k} \times k_{mod}$		$R_{2/3,k} \times k_{mod}$	
Number of fasteners			4,0x35	4,0x60	4,0x35	4,0x60
Flange A	Flange B					
12	1 x Ø10 Bolt	P	Min of: 17,6 / f 65,6 / ( f + 18)	Min of: 25,5 / f 65,6 / ( f + 18)	1,7	3,2
		L	Min of: 20,6 / f 65,6 / ( f + 18)		2,0	3,7
		M	Min of: 23,6 / f 65,6 / ( f + 18)		2,3	4,3
		S	Min of: 25,5 / f 65,6 / ( f + 18)		2,6	4,8
		I	Min of: 25,5 / f 65,6 / ( f + 18)		3,2	5,9

Bolt factor	for $F_1$	for $F_{2/3}$
$k_{ax}$	$(f + 34) / 9$	1,82
$k_{lat}$	-	1,00

For each bolt it's needed to check:  $R_{bolt,d,lateral} \geq k_{lat} \times F_{i,d}$  ;  $R_{bolt,d,axial} \geq k_{ax} \times F_{i,d}$ ; and also the combination

*Table D42-10 Modified characteristic capacity timber column to rigid support – 2 Angle Brackets, Nailing pattern 5*

2 Angle Brackets E19/3 per connection		Modified characteristic capacities (kN)				
Nailing pattern 5		Load duration	$R_{1,k} \times k_{mod}$		$R_{2/3,k} \times k_{mod}$	
Number of Fasteners			CNA4,0x35	CNA4,0x60	CNA4,0x35	CNA4,0x60
Flange A	Flange B					
12	1 x Ø10 Bolt	P	6,0	11,5	3,5	6,4
		L	7,0	13,4	4,1	7,5
		M	8,0	15,4	4,7	8,6
		S	9,0	17,3	5,3	9,7
		I	11,0	19,1	6,5	11,8

Bolt factor	for $F_1$	for $F_{2/3}$
$k_{ax}$	0,99	0,91
$k_{lat}$	-	0,50

For each bolt it's needed to check:  $R_{bolt,d,lateral} \geq k_{lat} \times F_{i,d}$  ;  $R_{bolt,d,axial} \geq k_{ax} \times F_{i,d}$  ; and also the combination

General notes to all capacity tables:

- b, e and f are in mm.
- Wane may not occur under the angle bracket.



## Annex D43 – ADR6090

### Product Name:

Product Name	Material reference acc. to clause II-1	Alternative product names
ADR6090	Steel ref. 1	-
ADR6090S	Steel ref. 2	-
ADR6090S2	Steel ref. 3	-

### Connector Size Range:

Model no.	Dimensions [mm]				Holes flange A	Holes flange B	
	A	B	C	Thickness	Ø5	Ø5	Ø12
ADR6090	90	60	60	2,5	5	5	1

### Drawing:

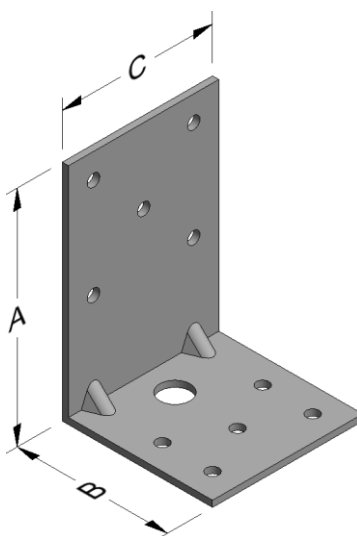

### Nailing pattern:

Nailing pattern 1

Nailing pattern 2

Flange A:

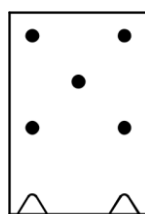
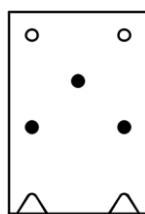

Flange B:

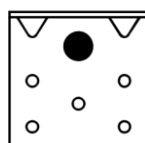
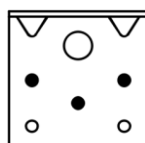

Beam to beam

Beam to rigid

*Table D43-1 Modified characteristic capacity timber beam to timber beam – 2 Angle Brackets*

2 Angle Brackets ADR6090 per connection			Modified characteristic capacity per connection (kN)		
Nailing pattern	Number of fasteners		Load duration	$R_{1,k} \times k_{mod}$	
	Flange A	Flange B		CNA Connector nail	
				4,0x40	4,0x60
Nailing pattern 1	3	3	P	1,8	2,7
			L	2,0	3,0
			M	2,3	3,2
			S	2,6	3,4
			I	2,9	3,8

*Table D43-2 Modified characteristic capacity timber beam to timber beam – 1 Angle Bracket*

1 Angle Bracket ADR6090 per connection			Modified characteristic capacity per connection (kN)		
Nailing pattern	Number of fasteners		Load duration	$R_{1,k} \times k_{mod}$	
	Flange A	Flange B		CNA Connector nail	
				4,0x40	4,0x60
Nailing pattern 1	3	3	P	$23 / (f + 28)$ max $20 / (f + 50)$	$23 / (f + 28)$ max $32 / (f + 50)$
			L	$23 / (f + 28)$ max $22 / (f + 50)$	$23 / (f + 28)$ max $37 / (f + 50)$
			M	$23 / (f + 28)$ max $26 / (f + 50)$	$23 / (f + 28)$
			S	$23 / (f + 28)$ max $29 / (f + 50)$	$23 / (f + 28)$
			I	$23 / (f + 28)$ max $35 / (f + 50)$	$23 / (f + 28)$

*Table D43-3 Characteristic capacity timber beam to rigid support – 1 & 2 Angle Brackets*

Connection with 1 or 2 ADR6090 per connection				Characteristic capacity per connection (kN)	
				1 Angle Bracket ADR6090 per connection	2 Angle Brackets ADR6090 per connection
Nailing pattern	Number of fasteners		Base material	$R_{1,k}$	
	Flange A	Flange B		CNA Connector nail	
				4,0x40 and 4,0x60	4,0x40 and 4,0x60
Nailing pattern 2	5	1 x Bolt	Concrete	min of: 86,5 / ((f+22)xk <sub>mod</sub> )  35 / ((f+8)*k <sub>mod</sub> )  8,9	min of:  15,7  9,9 / k <sub>mod</sub>
			Ligth weight concrete or masonry	min of: 75 / ((f+22)xk <sub>mod</sub> )  35 / ((f+8)*k <sub>mod</sub> )  8,3	min of:  14,5  9,1 / k <sub>mod</sub>
<b>for bolt: factor k<sub>ax</sub></b>				(f+23)/10	0,92

f in mm

For each bolt it is needed to check:  $R_{bolt,d,axial} \geq k_{ax} \times F_{i,d}$

## Annex D44 – ADR6035

### Product Name:

Product Name	Material reference acc. to clause II-1	Alternative product names
ADR6035	Steel ref. 1	-
ADR6035S	Steel ref. 2	-
ADR6035S2	Steel ref. 3	-

### Connector Size Range:

Model no.	Dimensions [mm]				Holes flange A	Holes flange B	
	A	B	C	Thickness	27 x 10	Ø5	Ø12
ADR6035	37	60	60	2,5	1	5	1

### Drawing:

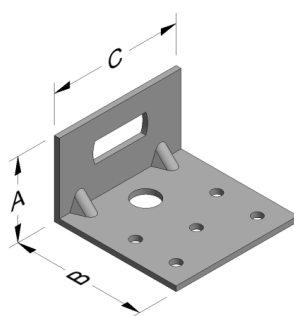

### Nailing pattern:

Nailing pattern 1

Flange A:

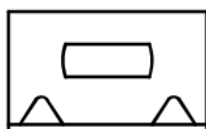

Flange B:

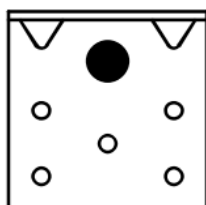

Steel strap to rigid

*Table D44-1 Characteristic capacity steel strap to rigid – 1 Angle Bracket*

1 Angle Bracket ADR6035 per connection			Characteristic capacity per connection (kN)
Nailing pattern	Number of fasteners		Base material
	Flange A	Flange B	
			$R_{1,k}$
			1 x M10 bolt
Nailing pattern 1	-	1 x M10 Bolt	Concrete
			Ligth weight concrete or masonry
<b>for bolt: factor <math>k_{ax}</math></b>			2,2

For each bolt it is needed to check:  $R_{bolt,d,axial} \geq k_{ax} \times F_{i,d}$

## Annex D45 – ABAI105

### Product Name:

Product Name	Material reference acc. to clause II-1	Alternative product names
ABAI105	Steel ref. 1	-

### Connector Size Range:

Model no.	Dimensions [mm]					Holes flange A		Holes flange B	
	A	B	C	D	Thickness	Ø5	Ø11	Ø3	Ø7
ABAI105	113	103	190	106	3,0	8	3	12	2

### Drawing:

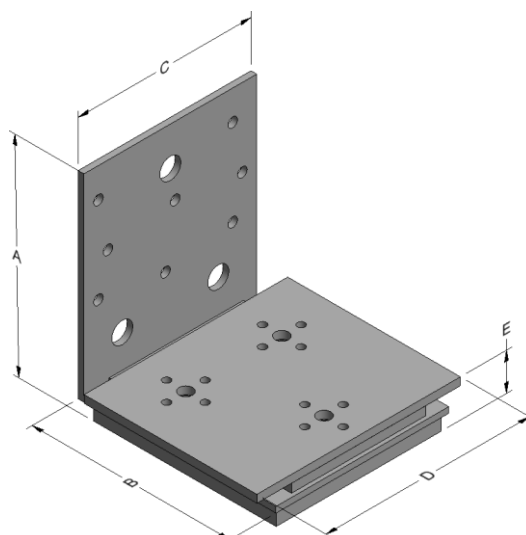

### Nailing pattern:

Nailing pattern 1

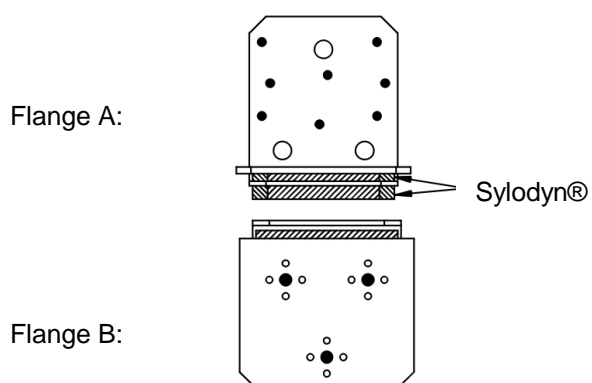

Timber (CLT wall) to Timber (floor)

**Table D45-1** *Modified characteristic capacity CLT wall to floor – 1 Angle Bracket*

1 Angle Bracket ABA1105 per connection			Characteristic capacity per connection (kN)				
Nailing pattern	Number of fasteners			$R_{1,k}$	$R_{2/3,k}$	$R_{4,k}$	$R_{5,k}$
	Flange A (Wall)	Flange B (Floor)					
Nailing pattern 1	8 x CNA4,0x60 or CSA5,0x50	3 x SDS25600	Characteristic value $R_k$ (kN)	1,4	1,4	3,3	1,6
			Slip modulus $k_{ser}$ (kN/mm)	0,8	0,68	1,16	0,8

**Table D45-2** *Ultimate limit state capacity CLT wall to floor – 1 Angle Bracket*

1 Angle Bracket ABA1105 per connection			Ultimate limit state capacity per connection (kN)			
Nailing pattern	Number of fasteners		$R_{1,u}$	$R_{2/3,u}$	$R_{4,u}$	$R_{5,u}$
	Flange A (Wall)	Flange B (Floor)				
Nailing pattern 1	8 x CNA4,0x60 or CSA5,0x50	3 x SDS25600	7,9	5,9	7,3	5,4

Ultimate limit state values shall only be used under rare disaster situations, e.g. disproportionate callapes, vehicle impact, etc...  
To evaluate the connected displacements, the slip modulus from table D45-1 can be used.

## Annex D46 – AG922

### Product Name:

Product Name	Material reference acc. to clause II-1	Alternative product names
AG922	Steel ref. 1	-
AG922S	Steel ref. 2	-
AG922S2	Steel ref. 3	-

### Connector Size Range:

Model no.	Dimensions [mm]				Holes flange A		Holes flange B	
	A	B	C	Thickness	Ø5	Ø13	Ø5	Ø13
AG922	121	79	150	2,5	26	26	18	13

### Drawing:

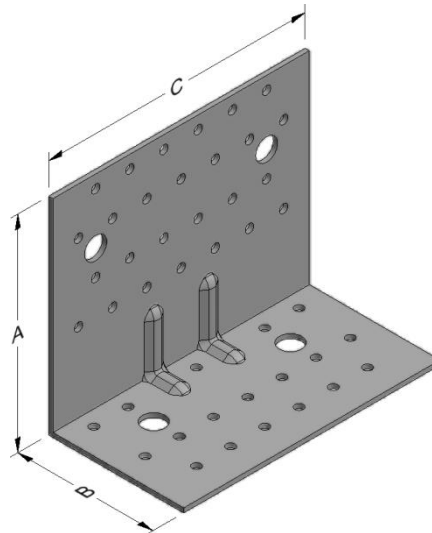

### Nailing pattern:

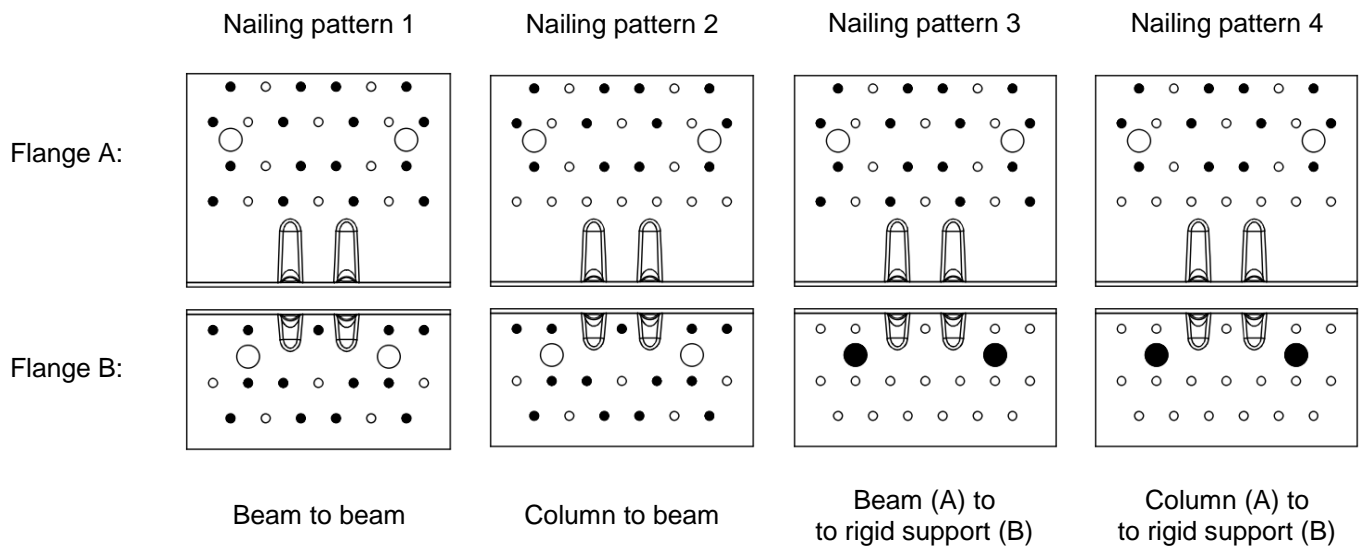



*Table D46-1 Characteristic capacity timber beam to timber beam – 2 Angle Brackets*

2 Angle Brackets AG922 per connection			Characteristic capacities per connection (kN)		Slip modulus $K_{ser}$ (kN/mm)	
Nailing pattern	Number of fasteners		$R_{1,k}$	$R_{2/3,k}$	For force	
	Flange A	Flange B			$F_1$	$F_2$
			CNA Connector nail 4,0x50		CNA Connector nail 4,0x50	
Nailing pattern 1	16	13	18,5	29,5	5,5	4,15

*Table D46-2 Characteristic capacity timber beam to rigid support – 2 Angle Brackets*

2 Angle Brackets AG922 per connection			Characteristic capacities per connection (kN)			Slip modulus $K_{ser}$ (kN/mm)		
Nailing pattern	Number of fasteners		$R_{1,k}$	$R_{2/3,k}$		For force $F_1$		For force $F_{2/3}$
	Flange A	Flange B				CNA Connector nail		
			4,0x50	4,0x35	4,0x50	4,0x50	4,0x35	4,0x50
Nailing pattern 3	16	2 x Ø12 Bolts	30,6	41,9	48,2	5,6	7,2	6,55

To table D46-2:

The bolt group must be able to resist to:

$$F_{2,d} \text{ [kN]}$$

$$M_{x,F2,d} = F_{2,d} \times 27\text{mm} \text{ [kNm]}$$

$$M_{y,F2,d} = F_{2,d} \times 70\text{mm} \text{ [kNm]}$$

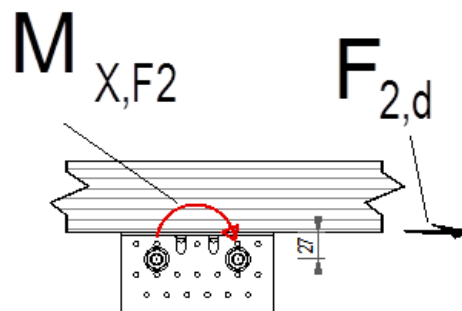
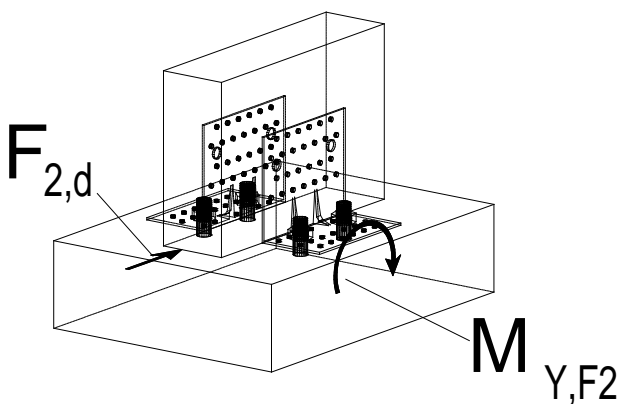

*Table D46-3 Characteristic capacity timber column to timber beam – 2 Angle Brackets*

2 Angle Brackets AG922 per connection			Characteristic capacities per connection (kN)	Slip modulus $K_{ser}$ (kN/mm)
Nailing pattern	Number of fasteners		$R_{1,k}$ CNA Connector nail 4,0x50	For force $F_1$ CNA Connector nail 4,0x50
	Flange A	Flange B		
Nailing pattern 2	12	13	19,5	3,18

*Table D46-4 Characteristic capacity timber column to rigid support – 2 Angle Brackets*

2 Angle Brackets AG922 per connection			Characteristic capacities per connection (kN)	Slip modulus $K_{ser}$ (kN/mm)
Nailing pattern	Number of fasteners		$R_{1,k}$ CNA Connector nail 4,0x50	For force $F_1$ CNA Connector nail 4,0x50
	Flange A	Flange B		
Nailing pattern 4	12	2 x Ø12 Bolts	37,5	10,59

*Table D46-5 Characteristic capacity timber beam to timber column – 1 Angle Bracket*

1 Angle Bracket AG922 per connection			Characteristic capacities per connection (kN)	Slip modulus $K_{ser}$ (kN/mm)
Nailing pattern	Number of fasteners		$R_{1,k}$ CNA Connector nail 4,0x50	For force $F_1$ CNA Connector nail 4,0x50
	Flange A	Flange B		
Nailing pattern 2	12	13	22,6	3,67

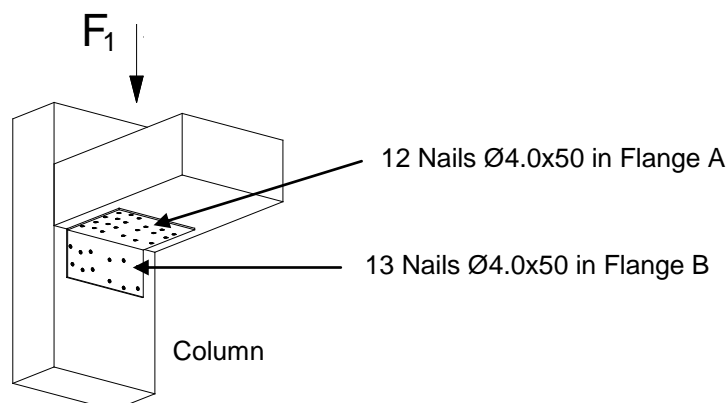

*Table D46-6 Characteristic capacity timber beam to rigid support – 1 Angle Bracket*

2 Angle Brackets AG922 per connection			Characteristic capacities per connection (kN)	Slip modulus $K_{ser}$ (kN/mm)
Nailing pattern	Number of fasteners		$R_{1,k}$ CNA Connector nail 4,0x50	For force $F_1$ CNA Connector nail 4,0x50
	Flange A	Flange B		
Nailing pattern 4	12	2 x Ø12 Bolts	24,8	3,71

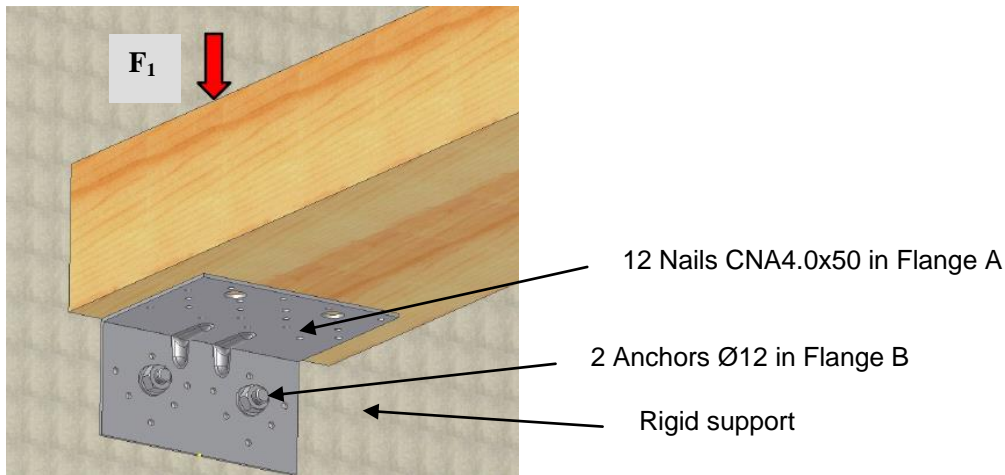

*Table D46-7 Bolt factors for D46-2, D46-4 & D46-6*

AG922	Connection with 2 Angle Brackets (to table D46-2 & D46-4)		Connection with 1 Angle Bracket (to table D46-6)
factor for:	$F_1$	$F_{2/3}$	$F_1$
$k_{ax}$	0,75	-	1,00
$k_{lat}$	-	see description	1,00

For each bolt-pair it's needed to check:  $R_{bolt,d,lateral} \geq k_{lat} \times F_{i,d}$  ;  $R_{bolt,d,axial} \geq k_{ax} \times F_{i,d}$ ; and also the combination.

## Annex D47 – ABR10525

### Product Name:

Product Name	Material reference acc. to clause II-1	Alternative product names
ABR10525	Steel ref. 1	-
ABR10525S	Steel ref. 2	-
ABR10525S2	Steel ref. 3	-

### Connector Size Range:

Model no.	Dimensions [mm]				Holes flange A			Holes flange B	
	A	B	C	Thickness	Ø5	Ø11	Ø14	Ø5	Ø14
ABR10525	105	105	90	2,5	10	2	1	14	1

### Drawing:

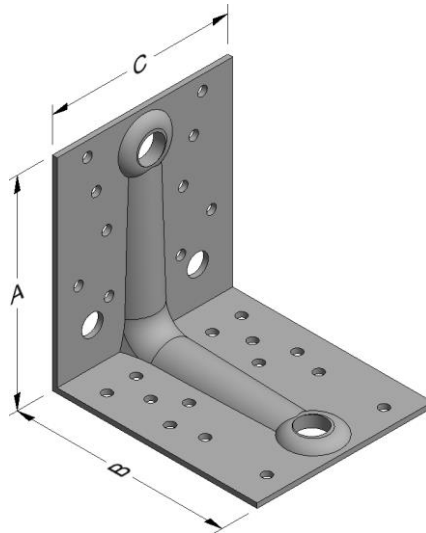

### Nailing pattern:

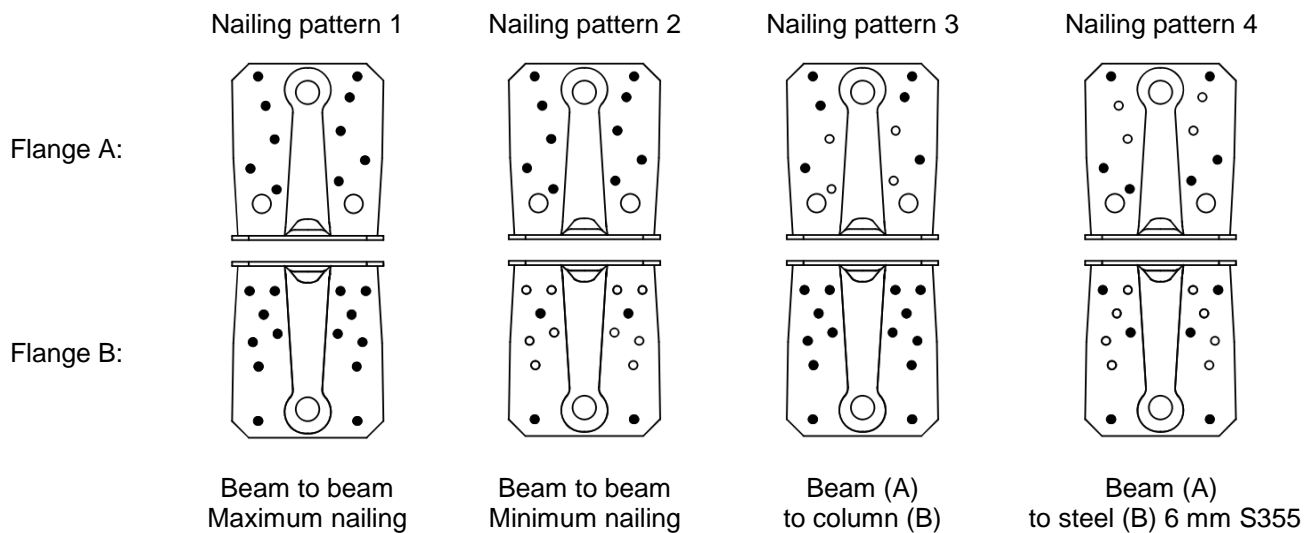

*Table D47-1 Modified characteristic capacity timber beam to timber beam – 2 Angle Brackets*

2 Angle Brackets ABR105 per connection			Modified characteristic capacity per connection (kN)									
Nailing pattern	Number of fasteners		Load duration	$R_{1,k} \times k_{mod}$			$R_{2/3,k} \times k_{mod}$			$R_{4/5,k} \times k_{mod}$		
	Flange A	Flange B		CNA Connector nail								
				4,0x35	4,0x40	4,0x60	4,0x35	4,0x40	4,0x60	4,0x35	4,0x40	4,0x60
Nailing pattern 1	10	14	P	7,6	10,3	17,7	6,4	7,3	11,8	$\frac{6,8 \cdot b + 903}{e}$ max 7,1	$\frac{7,2 \cdot b + 901}{e}$ max 8,2	$\frac{8,6 \cdot b + 894}{e}$ max 12,2
			L	8,9	12,0	20,6	7,5	8,5	13,8	$\frac{7,1 \cdot b + 901}{e}$ max 8,0	$\frac{7,5 \cdot b + 899}{e}$ max 9,2	$\frac{9,1 \cdot b + 891}{e}$ max 13,9
			M	10,2	13,8	23,6	8,6	9,7	15,8	$\frac{7,4 \cdot b + 900}{e}$ max 8,8	$\frac{7,9 \cdot b + 898}{e}$ max 7,9	$\frac{9,7 \cdot b + 888}{e}$ max 15,6
			S	11,4	15,5	26,5	9,7	10,9	17,7	$\frac{7,7 \cdot b + 898}{e}$ max 9,7	$\frac{8,2 \cdot b + 896}{e}$ max 11,2	$\frac{10,3 \cdot b + 885}{e}$ max 17,4
			I	14,0	18,9	32,4	11,8	13,4	21,7	$\frac{8,3 \cdot b + 895}{e}$ max 11,4	$\frac{8,9 \cdot b + 892}{e}$ max 13,3	$\frac{11,5 \cdot b + 879}{e}$ max 20,8

b and e are in mm.

Table D47-2 Modified characteristic capacity timber beam to timber beam – 1 Angle Bracket

Table D47-2.1

1 Angle Bracket ABR10525 per connection			Modified characteristic capacity per connection (kN)						
Nailing pattern	Number of fasteners		Load duration	$R_{1,k} \times k_{mod}$			$R_{2/3,k} \times k_{mod}$		
	Flange A	Flange B		CNA Connector nail					
				4,0x35	4,0x40	4,0x60	4,0x35	4,0x40	4,0x60
Nailing pattern 1	8	10	P	$f \leq 25$ : <u>221</u> f+75	$f \leq 27$ : <u>249</u> f+75	$f \leq 33$ : <u>358</u> f+75	3,2	3,6	5,9
				$f > 25$ : <u>55</u> f	$f > 27$ : <u>66</u> f	$f > 33$ : <u>110</u> f			
			L	$f \leq 27$ : <u>244</u> f+75	$f \leq 29$ : <u>276</u> f+75	$f \leq 35$ : <u>404</u> f+75	3,8	4,3	6,9
				$f > 27$ : <u>64</u> f	$f > 29$ : <u>77</u> f	$f > 35$ : <u>129</u> f			
			M	$f \leq 29$ : <u>267</u> f+75	$f \leq 31$ : <u>303</u> f+75	$f \leq 36$ : <u>450</u> f+75	4,3	4,9	7,9
$f > 29$ : <u>74</u> f	$f > 31$ : <u>88</u> f	$f > 36$ : <u>147</u> f							
S	$f \leq 30$ : <u>290</u> f+75	$f \leq 32$ : <u>331</u> f+75	$f \leq 35$ : <u>496</u> f+75	4,8	5,5	8,9			
	$f > 30$ : <u>83</u> f	$f > 32$ : <u>99</u> f	$f > 35$ : <u>159</u> f						
I	$f \leq 32$ : <u>336</u> f+75	$f \leq 34$ : <u>386</u> f+75	$f \leq 28$ : <u>587</u> f+75	5,9	6,7	10,8			
	$f > 32$ : <u>101</u> f	$f > 34$ : <u>121</u> f	$f > 28$ : <u>159</u> f						

f, e and b are in mm.

Table D47-2.2

1 Angle Bracket ABR10525 per connection			Modified characteristic capacity per connection (kN)						
Nailing pattern	Number of fasteners		Load duration	$R_{4,k} \times k_{mod}$			$R_{5,k} \times k_{mod}$		
	Flange A	Flange B		CNA Connector nail					
			4,0x35	4,0x40	4,0x60	4,0x35	4,0x40	4,0x60	
Nailing pattern 1	8	10	P	e ≤ 26: 8,0	e ≤ 25: 8,8	e ≤ 22: 11,3	e ≤ 60:	e ≤ 58:	e ≤ 55:
				26 < e ≤ 115:	25 < e ≤ 123:	22 < e ≤ 156:	<u>64</u> 83-e	<u>77</u> 83-e	<u>129</u> 83-e
				<u>211</u> e	<u>220</u> e	<u>254</u> e	60 < e ≤ 2,40·b-32:	58 < e ≤ 2,24·b-27:	55 < e ≤ 1,84·b-15:
				e > 115:	e > 123:	e > 156:	2,8	3,2	4,7
				<u>60</u> e-82,5	<u>72</u> e-82,5	<u>120</u> e-82,5	e > 2,40·b-32:	e > 2,24·b-27:	e > 1,84·b-15:
							<u>6,8-b-323</u> e-83	<u>7,2-b-349</u> e-83	<u>8,6-b-454</u> e-83
			L	e ≤ 23: 9,4	e ≤ 22: 10,3	e ≤ 20: 13,2	e ≤ 59:	e ≤ 57:	e ≤ 54:
				23 < e ≤ 121:	22 < e ≤ 130:	20 < e ≤ 172:	<u>75</u> 83-e	<u>90</u> 83-e	<u>150</u> 83-e
				<u>218</u> e	<u>228</u> e	<u>268</u> e	59 < e ≤ 2,26·b-30:	57 < e ≤ 2,11·b-26:	54 < e ≤ 1,74·b-14:
				e > 121:	e > 130:	e > 172:	3,1	3,6	5,3
				<u>70</u> e-82,5	<u>84</u> e-82,5	<u>140</u> e-82,5	e > 2,26·b-30:	e > 2,11·b-26:	e > 1,74·b-14:
							<u>7,1-b-345</u> e-83	<u>7,5-b-375</u> e-83	<u>9,1-b-497</u> e-83
			M	e ≤ 21: 10,7	e ≤ 20: 11,7	e ≤ 19: 15,1	e ≤ 58:	e ≤ 56:	e ≤ 53:
				21 < e ≤ 128:	20 < e ≤ 139:	19 < e ≤ 146:	<u>86</u> 83-e	<u>103</u> 83-e	<u>172</u> 83-e
				<u>226</u> e	<u>237</u> e	<u>282</u> e	58 < e ≤ 2,15·b-29:	56 < e ≤ 2,00·b-24:	53 < e ≤ 1,66·b-12:
				e > 128:	e > 139:	146 < e ≤ 213:	3,4	3,9	5,9
				<u>80</u> e-82,5	<u>96</u> e-82,5	<u>219,8</u> e-32,5	e > 2,15·b-29:	e > 2,00·b-24:	e > 1,66·b-12:
						e > 213:	<u>7,4-b-367</u> e-83	<u>7,9-b-401</u> e-83	<u>9,7-b-541</u> e-83
					<u>159</u> e-82,5				
			S	e ≤ 19: 12,1	e ≤ 19: 13,2	e ≤ 17: 17	e ≤ 57:	e ≤ 55:	e ≤ 53:
				19 < e ≤ 135:	19 < e ≤ 147:	17 < e ≤ 125:	<u>97</u> 83-e	<u>116</u> 83-e	<u>193</u> 83-e
				<u>233</u> e	<u>245</u> e	<u>297</u> e	57 < e ≤ 2,05·b-28:	55 < e ≤ 1,91·b-23:	53 < e ≤ 1,59·b-11:
				e > 135:	e > 147:	125 < e ≤ 300:	3,7	4,3	6,5
				<u>90</u> e-82,5	<u>108</u> e-82,5	<u>219,8</u> e-32,5	e > 2,05·b-28:	e > 1,91·b-23:	e > 1,59·b-11:
		e > 300:		<u>7,7-b-388</u> e-83	<u>8,2-b-428</u> e-83	<u>10,3-b-585</u> e-83			
		<u>179</u> e-82,5							
I	e ≤ 17: 14,7	e ≤ 16: 16,1	e ≤ 16: 20,8	e ≤ 55:	e ≤ 54:	e ≤ 52:			
	17 < e ≤ 149:	16 < e ≤ 165:	16 < e ≤ 254:	<u>118</u> 83-e	<u>141</u> 83-e	<u>236</u> 83-e			
	<u>247</u> e	<u>263</u> e	<u>325</u> e	55 < e ≤ 1,90·b-26:	54 < e ≤ 1,78·b-21:	52 < e ≤ 1,49·b-8:			
	e > 149:	e > 165:	e > 254:	4,4	5,0	7,7			
	<u>110</u> e-82,5	<u>132</u> e-82,5	<u>219</u> e-82,5	e > 1,90·b-26:	e > 1,78·b-21:	e > 1,49·b-8:			
				<u>8,3-b-432</u> e-83	<u>8,9-b-480</u> e-83	<u>11,5-b-672</u> e-83			

f, e and b are in mm.

Table D47-3 Characteristic capacity timber beam to timber beam – 2 Angle Bracket

2 Angle Brackets ABR10525 per connection			Characteristic capacities per connection (kN)								
			R <sub>1,k</sub>			R <sub>2/3,k</sub>			R <sub>4/5,k</sub>		
Nailing pattern	Number of fasteners		CNA Connector nail								
	Flange A	Flange B	4,0x35	4,0x40	4,0x60	4,0x35	4,0x40	4,0x60	4,0x35	4,0x40	4,0x60
Nailing pattern 2	6	6	4,80	5,70	9,50	9,7	10,6	14,3	a=6,8	a=7,1	a=8,3
									y=10,1	y=11,7	y=17,8
									$\min \left\{ \begin{array}{l} \frac{a}{k_{\text{mod}}^{0,75}} \times b + 902 / k_{\text{mod}} \\ \frac{y}{k_{\text{mod}}^{0,2}} \end{array} \right\} / e$		

e and f in (mm); b = the width of the timber in (mm)

Table D47-4 Characteristic capacity timber beam to timber beam – 1 Angle Bracket

1 Angle Bracket ABR10525 per connection			Characteristic capacities per connection (kN)											
			R <sub>1,k</sub>			R <sub>2/3,k</sub>			R <sub>4,k</sub>			R <sub>5,k</sub>		
Nailing pattern	Number of fasteners		CNA Connector nail											
	Flange A	Flange B	4,0x35	4,0x40	4,0x60	4,0x35	4,0x40	4,0x60	4,0x35	4,0x40	4,0x60	4,0x35	4,0x40	4,0x60
Nailing pattern 2	6	6	a=224	a=249	a=350	4,9	5,3	7,2	a=3,4	a=3,7	a=4,7	a=6,9	a=7,2	a=8,3
			y=107	y=129	y=214				y=228	y=238	y=278	y=354	y=384	y=503
			$\min \left\{ \begin{array}{l} \frac{a}{(f+75) \times k_{\text{mod}}^{0,4}} \\ \frac{y}{f} \\ \frac{159}{f \times k_{\text{mod}}} \end{array} \right\}$						$\min \left\{ \begin{array}{l} \frac{a}{k_{\text{mod}}^{0,75} \times e} \\ \frac{z}{e - 82,5} \end{array} \right\}$			$\min \left\{ \begin{array}{l} \frac{a \times b - y}{k_{\text{mod}}^{0,7} \times (e - 83)} \\ \frac{z}{k_{\text{mod}}^{0,2}} \end{array} \right\}$		

e and f in (mm); b = the width of the timber in (mm)

Table D47-5 Characteristic capacity timber beam to 6mm steel beam – 2 Angle Brackets

2 Angle Brackets ABR10525 per connection			Characteristic capacity (kN) – timber to 6 mm steel
Nailing pattern	Flange A	Flange B	R <sub>1,k</sub>
Nailing pattern 4	10 x CNA4,0x60	4 x PDPA-75	15,3

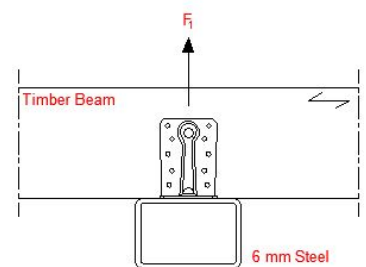



*Table D47-6 Characteristic capacity timber beam to timber column – 1 Angle Bracket*

2 Angle Brackets ABR105 per connection			Characteristic capacity per connection (kN)			
			$R_{1,k}$		$R_{2,k}$	
Nailing pattern	Number of fasteners		CNA4,0x40	CNA4,0x60	CNA4,0x40	CNA4,0x60
	Flange A (Beam)	Flange B (Column)				
Nailing pattern 3	6	14	13,7	18,3	1,5	2,5

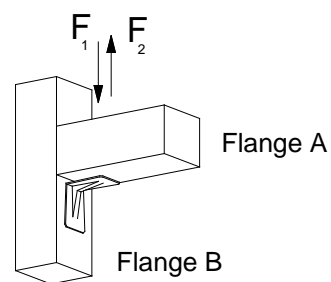

## Annex D48 – ABR7015

### Product Name:

Product Name	Material reference acc. to clause II-1	Alternative product names
ABR7015	Steel ref. 1	-
ABR7015S	Steel ref. 2	-
ABR7015S2	Steel ref. 3	-

### Connector Size Range:

Model no.	Dimensions [mm]				Holes flange A		Holes flange B	
	A	B	C	Thickness	Ø5	Ø9	Ø5	Ø7
ABR7015	70	70	55	1,5	8	1	8	1

### Drawing:

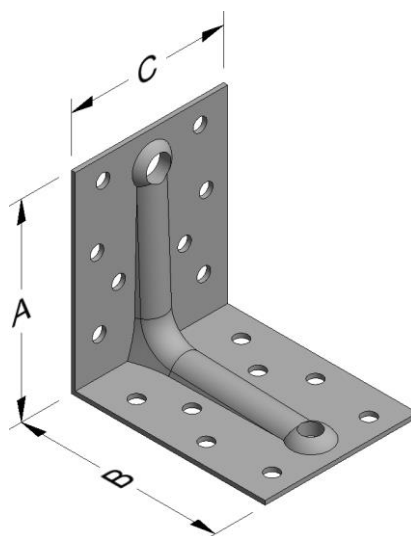

### Nailing pattern:

Nailing pattern 1

Flange A:

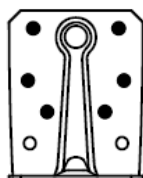

Flange B:

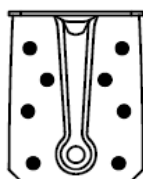

Beam to beam  
Maximum nailing

*Table D48-1 Modified characteristic capacity timber beam to timber beam – 2 Angle Brackets*

2 Angle Brackets AB90 per connection			Modified characteristic capacity per connection (kN)						
Nailing pattern	Number of fasteners		Load duration	$R_{1,k} \times k_{mod}$		$R_{2/3,k} \times k_{mod}$		$R_{4/5,k} \times k_{mod}$	
	Flange A	Flange B		CNA Connector nail					
				4,0x35	4,0x40	4,0x35	4,0x40	4,0x35	4,0x40
Nailing pattern 1	6	8	P	3,1	3,7	4,0	4,4	$\frac{1,5 \cdot b + 277}{e}$ max 5,0	$\frac{1,8 \cdot b + 302}{e}$ max 6,0
			L	3,6	4,3	4,7	5,1	$\frac{1,7 \cdot b + 298}{e}$ max 5,8	$\frac{2,1 \cdot b + 327}{e}$ max 7,0
			M	4,2	4,9	5,3	5,9	$\frac{2,0 \cdot b + 319}{e}$ max 6,7	$\frac{2,4 \cdot b + 352}{e}$ max 8,0
			S	4,7	5,5	6,0	6,6	$\frac{2,2 \cdot b + 340}{e}$ max 7,5	$\frac{2,6 \cdot b + 378}{e}$ max 9,0
			I	5,7	6,7	7,3	8,1	$\frac{2,7 \cdot b + 382}{e}$ max 9,2	$\frac{3,2 \cdot b + 428}{e}$ max 11,0

b and e are in mm.

Table D48-2 Modified characteristic capacity timber beam to timber beam – 1 Angle Bracket

1 Angle Bracket ABR7015 per connection			Modified characteristic capacity per connection (kN)								
Nailing pattern	Number of fasteners		Load duration	$R_{1,k} \times k_{mod}$		$R_{2/3,k} \times k_{mod}$		$R_{4,k} \times k_{mod}$		$R_{5,k} \times k_{mod}$	
	Flange A	Flange B		4,0x35	4,0x40	4,0x35	4,0x40	CNA Connector nail			
								4,0x35	4,0x40	4,0x35	4,0x40
Nailing pattern 1	6	8	P	$f \leq 27$ : <u>75</u> $f+60$	$f \leq 29$ : <u>87</u> $f+60$	2,0	2,2	$e \leq 6$ : 6,0	$e \leq 7$ : 6,6	$e \leq 42$ :	$e \leq 42$ :
				$f > 27$ : <u>24</u> f	$f > 29$ : <u>28</u> f			$6 < e \leq 220$ : <u>38</u> e	$7 < e \leq 102$ : <u>46</u> e	$42 < e \leq 0,71 \cdot b + 21$ : 2,1	$42 < e \leq 0,71 \cdot b + 21$ : 2,5
			L	$f \leq 29$ : <u>85</u> $f+60$	$f \leq 24$ : <u>98</u> $f+60$	2,3	2,6	$e \leq 6$ : 7,0	$e \leq 7$ : 7,7	$e \leq 42$ :	$e \leq 42$ :
				$f > 29$ : <u>27</u> f	$f > 24$ : <u>28</u> f			$6 < e \leq 115$ : <u>44</u> e	$7 < e \leq 71$ : <u>53</u> e	$42 < e \leq 0,71 \cdot b + 21$ : 2,4	$42 < e \leq 0,71 \cdot b + 21$ : 2,9
			M	$f \leq 25$ : <u>94</u> $f+60$	$f \leq 21$ : <u>110</u> $f+60$	2,7	2,9	$e \leq 6$ : 8,0	$e \leq 7$ : 8,8	$e \leq 42$ :	$e \leq 42$ :
$f > 25$ : <u>28</u> f	$f > 21$ : <u>28</u> f	$6 < e \leq 80$ : <u>51</u> e		$7 < e \leq 58$ : <u>61</u> e	$42 < e \leq 0,71 \cdot b + 21$ : 2,7			$42 < e \leq 0,71 \cdot b + 21$ : 3,3			
S	$f \leq 22$ : <u>104</u> $f+60$	$f \leq 18$ : <u>121</u> $f+60$	3,0	3,3	$e \leq 6$ : 9,1	$e \leq 7$ : 9,9	$e \leq 42$ :	$e \leq 42$ :			
	$f > 22$ : <u>28</u> f	$f > 18$ : <u>28</u> f			$6 < e \leq 64$ : <u>57</u> e	$7 < e \leq 51$ : <u>68</u> e	$42 < e \leq 0,71 \cdot b + 21$ : 3,1	$42 < e \leq 0,71 \cdot b + 21$ : 3,7			
I	$f \leq 18$ : <u>123</u> $f+60$	$f \leq 15$ : <u>144</u> $f+60$	3,7	4,0	$e \leq 6$ : 11,1	$e \leq 6$ : 12,1	$e \leq 42$ :	$e \leq 42$ :			
	$f > 18$ : <u>28</u> f	$f > 15$ : <u>28</u> f			$6 < e \leq 50$ : <u>70</u> e	$6 < e \leq 48$ : <u>73</u> e	$42 < e \leq 0,71 \cdot b + 21$ : 3,8	$42 < e \leq 0,71 \cdot b + 21$ : 4,5			
					$e > 50$ : <u>35</u> e-25	$e > 48$ : <u>35</u> e-25	$e > 0,71 \cdot b + 21$ : <u>2,21 \cdot b - 120</u> e-60	$e > 0,71 \cdot b + 21$ : <u>2,65 \cdot b - 144</u> e-60			
							$e > 0,71 \cdot b + 21$ : <u>1,47 \cdot b - 80</u> e-60	$e > 0,71 \cdot b + 21$ : <u>1,76 \cdot b - 96</u> e-60			
							$e > 0,71 \cdot b + 21$ : <u>1,72 \cdot b - 94</u> e-60	$e > 0,71 \cdot b + 21$ : <u>2,06 \cdot b - 112</u> e-60			
							$e > 0,71 \cdot b + 21$ : <u>2,35 \cdot b - 128</u> e-60	$e > 0,71 \cdot b + 21$ : <u>3,23 \cdot b - 176</u> e-60			

f, e and b are in mm.

**Annex D49 – ACR / ACRL****Product Name:**

<b>Product Name</b>	<b>Material reference acc. to clause II-1</b>	<b>Alternative product names</b>
ACR7010	Steel ref. 1	-
ACR7012	Steel ref. 1	-
ACR7015	Steel ref. 1	-
ACR9012	Steel ref. 1	-
ACR9015	Steel ref. 1	-
ACR9020	Steel ref. 1	-
ACR10512	Steel ref. 1	-
ACR10515	Steel ref. 1	-
ACR10520	Steel ref. 1	-
ACRL10520	Steel ref. 1	-
ACR7010S	Steel ref. 2	-
ACR7012S	Steel ref. 2	-
ACR7015S	Steel ref. 2	-
ACR9012S	Steel ref. 2	-
ACR9015S	Steel ref. 2	-
ACR9020S	Steel ref. 2	-
ACR10512S	Steel ref. 2	-
ACR10515S	Steel ref. 2	-
ACR10520S	Steel ref. 2	-
ACRL10520S	Steel ref. 2	-
ACR7010S2	Steel ref. 3	-
ACR7012S2	Steel ref. 3	-
ACR7015S2	Steel ref. 3	-
ACR9012S2	Steel ref. 3	-
ACR9015S2	Steel ref. 3	-
ACR9020S2	Steel ref. 3	-
ACR10512S2	Steel ref. 3	-
ACR10515S2	Steel ref. 3	-
ACR10520S2	Steel ref. 3	-
ACRL10520S2	Steel ref. 3	-

**Connector Size Range:**

Model no.	Dimensions [mm]				Holes flange A				Holes flange B			
	A	B	C	Thickness	Ø5	Ø8,5	Ø11	Ø11x31	Ø5	Ø8,5	Ø11	Ø11x31
ACR7010	70	70	55	1,0	6	1	-	-	6	1	-	-
ACR7012	70	70	55	1,25	6	1	-	-	6	1	-	-
ACR7015	70	70	55	1,5	6	1	-	-	6	1	-	-
ACR9012	88	88	65	1,25	10	-	1	-	5	-	1	-
ACR9015	88	88	65	1,5	10	-	1	-	5	-	1	-
ACR9020	88	88	65	2,0	10	-	1	-	5	-	1	-
ACR10512	105	105	90	1,25	10	-	3	-	14	-	1	-
ACR10515	105	105	90	1,5	10	-	3	-	14	-	1	-
ACR10520	105	105	90	2,0	10	-	3	-	14	-	1	-
ACRL10520	105	105	90	2,0	10	-	2	1	14	-	-	1

**Drawing:**

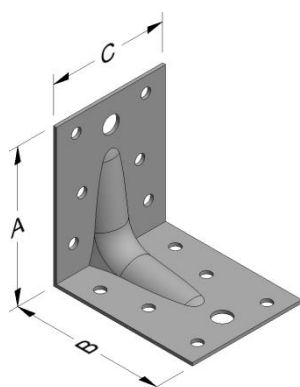

ACR70

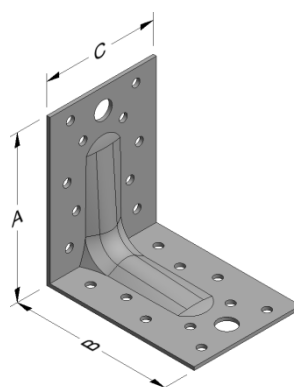

ACR90

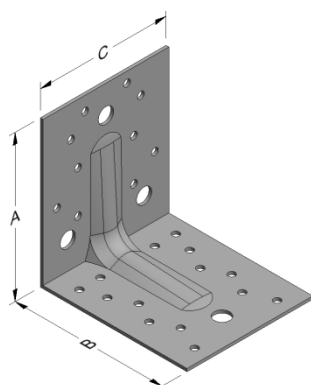

ACR100

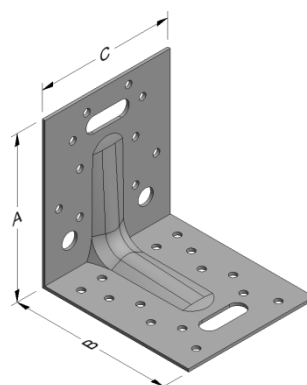

ACRL100

**Nailing pattern:**

	Nailing pattern 1	Nailing pattern 2	Nailing pattern 3	Nailing pattern 4
Flange A:				
Flange B:				
	ACR7010, ACR7012, ACR7015 Timber to Timber Maximum nailing	ACR9012, ACR9015, ACR9020 Timber to Timber Maximum nailing	ACR10512, ACR10515, ACRL10520 Timber to Timber Maximum nailing	ACR10520, ACRL10520 Timber to rigid
	Nailing pattern 5	Nailing pattern 6	Nailing pattern 7	
Flange A:				
Flange B:				
	ACR10520, ACRL10520 Timber to rigid	ACR10520, ACRL10520 Timber to rigid	ACR10520, ACRL10520 Timber to rigid	

Table D49-1 Characteristic capacity timber to timber – 2 Angle Brackets

2 Angle Brackets per connection			Characteristic capacity per connection (kN)		
Angle Bracket	Nailing pattern	CNA Connector nail	$R_{1,k}$	$R_{2/3,k}$	$R_{4/5,k}$
ACR7010	Nailing pattern 1 Flange A: 4 Flange B: 6	4,0x35	2,2		
ACR7012		4,0x35	3,2		
ACR7015		4,0x35	3,9		
		4,0x40	5,3	5,0	$\frac{2.13b+165}{k_{mod}^{0,7}}$ e max 8,0
		4,0x60	8,9	7,3	$\frac{3.54b+200}{k_{mod}^{0,6}}$ e max 13,2
ACR9012	Nailing pattern 2 Flange A: 8 Flange B: 10	4,0x35	7,9		
ACR9015		4,0x35	8,9		
ACR9020		4,0x35	9,2		
		4,0x40	8,0	9,3	$\frac{6.7b+369}{k_{mod}^{0,7}}$ e - 10,7 max 9,7
		4,0x60	13,3	11,9	$\frac{8b+343}{k_{mod}}$ e - 10,7 max $14,5/k_{mod}^{0,15}$
ACR10512	Nailing pattern 3 Flange A: 10 Flange B: 14	4,0x35	10,9		
ACR10515		4,0x35	13,0		
ACR10520 ACRL10520		4,0x35	13,4		
		4,0x40	10,8	14,5	$\frac{12.7b}{k_{mod}^{0,7}} + \frac{565}{k_{mod}}$ e - 10,7 max $14,1/k_{mod}^{0,25}$
		4,0x60	17,9	20,3	$\frac{15.6b}{k_{mod}^{0,6}} + \frac{556}{k_{mod}}$ e - 10,7 max $21,2/k_{mod}^{0,15}$

b and e are in mm.

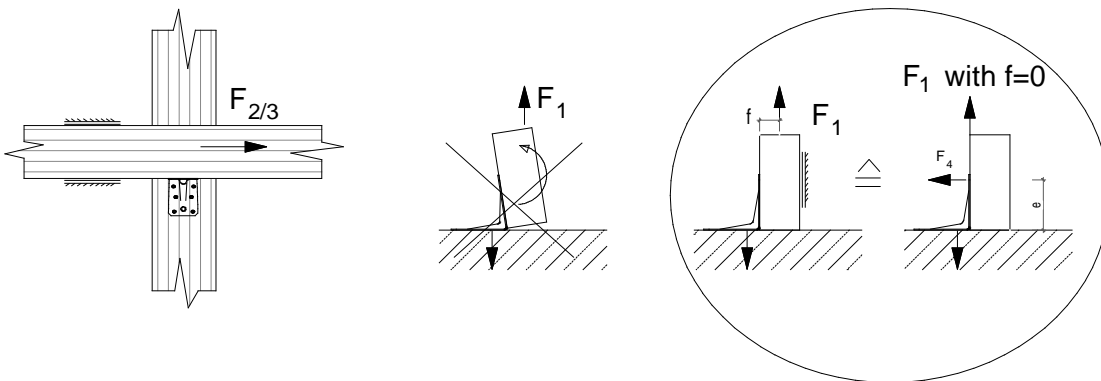

Table D49-2 Characteristic capacity timber to timber – 1 Angle Bracket

1 Angle Bracket per connection		Characteristic capacity per connection (kN)									
Angle Bracket	Nailing pattern	R <sub>1,k</sub>		R <sub>2/3,k</sub>		R <sub>4,k</sub>				R <sub>5,k</sub>	
		4,0x40	4,0x60	4,0x40	4,0x60	CNA Connector nail				4,0x40	4,0x60
						4,0x40	4,0x60			4,0x40	4,0x60
ACR7015	Nailing pattern 1 Flange A: 4 Flange B: 6	2,7	4,5	2,5	3,7	min of: 2,4	min of: 3,1	min of: 2,5	min of: 4,2		
						$51$ $e \cdot k_{mod}$	$51$ $e \cdot k_{mod}$	$30$ $55 \cdot e$	$49$ $55 \cdot e$	$2,7b+53$ $e$	$4,4b+89$ $e$
ACR9020	Nailing pattern 2 Flange A: 8 Flange B: 10	4	6,7	4,7	6	$e=$	$e=$	min of:	min of:	min of:	min of:
						1	4,7	1	6,1	$5,8$	$8,5$
						20	$4,3/k_{mod}^{0,2}$	20	6,1	$k_{mod}^{0,4}$	$k_{mod}^{0,25}$
						50	$1,8/k_{mod}^{0,2}$	50	$2,6/k_{mod}^{0,2}$ ; $2,2/k_{mod}$		
						75	$1,2/k_{mod}^{0,2}$	75	$1,8/k_{mod}^{0,2}$ ; $1,5/k_{mod}$	$7,7$	$12,9$
						100	0,8	100	$1,1/k_{mod}^{0,2}$ ; $1,0/k_{mod}$	$68 - e$	$68 - e$
						125	0,5	125	0,8 ; $0,7/k_{mod}$	$7,2/(k_{mod}^{0,75} \cdot b-308/k_{mod}^{0,55})$	$8,8/(k_{mod}^{0,6} \cdot b-408/k_{mod}^{0,45})$
150	0,4	150	0,8 ; $0,6/k_{mod}$	$e - 68$	$e - 68$						
ACR10520 ACRL10520	Nailing pattern 3 Flange A: 10 Flange B: 14	5,4	9	7,3	10,2	$e=$	$e=$	min of:	min of:	min of:	min of:
						1	7,2	1	9,2	$8,1$	$11,2$
						20	7,2	20	9,2	$k_{mod}^{0,45}$	$k_{mod}^{0,35}$
						50	$3,4/k_{mod}^{0,35}$	50	$4,9/k_{mod}^{0,35}$		
						75	$2,3/k_{mod}^{0,35}$	75	$3,3/k_{mod}^{0,3}$	$13,7$	$22,8$
						100	$1,7/k_{mod}^{0,35}$	100	$2,3/k_{mod}^{0,3}$ ; $2,3/k_{mod}$	$85 - e$	$85 - e$
						125	$1,4/k_{mod}^{0,35}$	125	$1,9/k_{mod}^{0,3}$ ; $1,7/k_{mod}$	$12,8/(k_{mod}^{0,7} \cdot b-639/k_{mod}^{0,55})$	$15,7/(k_{mod}^{0,6} \cdot b-840/k_{mod}^{0,45})$
150	$1,1/k_{mod}^{0,35}$	150	$1,4/k_{mod}^{0,3}$ ; $1,4/k_{mod}$	$e - 85$	$e - 85$						

b and e are in mm.

The capacities have been found based on the assumption that the purlin is prevented from rotation.



**Table D49-3** *Characteristic capacity timber beam to rigid support – 2 Angle Brackets*

1 Angle Bracket ACR10520 or ACRL10520 per connection			Characteristic capacity per connection (kN)										
Nailing pattern	Number of fasteners		R <sub>1,k</sub>					R <sub>2,k</sub>					
	Flange A	Flange B	CNA Connector nail										
			4.0x35	4.0x40	4.0x50	4.0x60	4.0x75	4.0x35	4.0x40	4.0x50	4.0x60	4.0x75	
Nailing pattern 4	10	2 x Ø10 Bolts	24,1	27,6	28,5	28,5	28,5	10,8	11,7	14,2	15,1	16,0	
Nailing pattern 5	10	1 x Ø10 Bolt	10,1	11,7	15,0	15,0	15,0	6,0	7,0	9,0	10,5	11,7	
Nailing pattern 6 & 7	1 x Ø10 Bolt	2 x Ø10 Bolts	7,5*					-	-	-	-	-	-

\*In this case the test had shown that the limiting factor is the bolt resistance of connection ACRL to timber. The bolt resistance must be calculated using the Eurocode 5 §8.2.3 and consider only failure mode (j) and (k).

## Annex D50 – MAXIMUS

### Product Name:

Product Name	Material reference acc. to clause II-1	Alternative product names
MAXIMUS	Steel ref. 1	-
MAXIMUSS	Steel ref. 2	-
MAXIMUSS2	Steel ref. 3	-

### Connector Size Range:

Model no.	Dimensions [mm]					Small holes	Large holes
	A	B	C	D	Thickness	Ø5	Ø21
MAXIMUS	494	623	$100 \leq C \leq 240$	$15 + C + 15$	2,5	10	2

### Drawing:

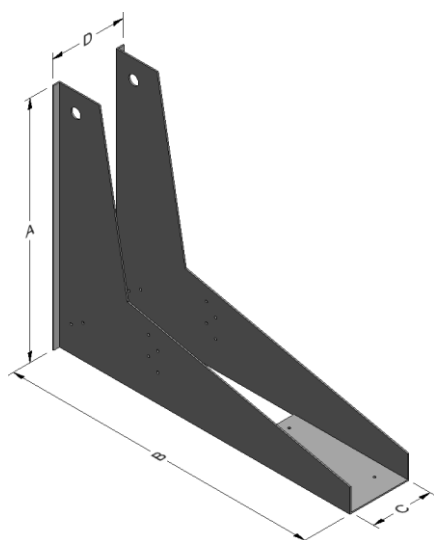

### Nailing pattern:

Nailing pattern 1

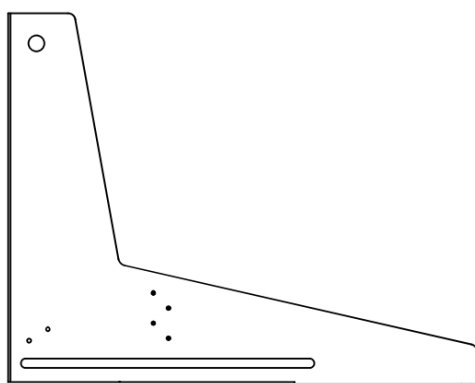

4 x CSA5,0x50 on each side

Nailing pattern 2



CSA5,0x50 on the bottom

Nailing pattern 3

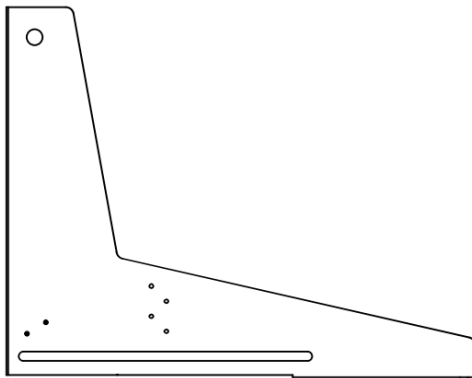

CSA5,0x50 on each side

Nailing pattern 4

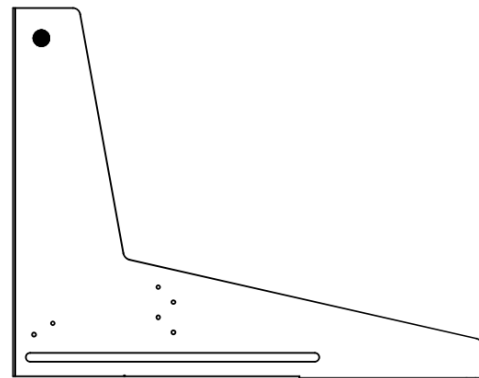

1x bolt M20 or a 20 mm dowel with additional securing pins

For a downward force, at least the fasteners shown in Nailing pattern 1, 2 and 3 shall be inserted. For an uplift force, the fasteners shown in Nailing pattern 1, 2, 3, and 4 are required.

**Design Basis:**

The loads have been assumed to act on a cantilevering horizontal timber member fastened to a vertical timber by the MAXIMUS connector using the fastener pattern shown in figure Nailing pattern 1 up to 4. Other spans or loads can be verified by engineering judgement. The relevant moment to evaluate deflection is stated as:  $M=q \cdot L^2/2$

Possible load distributions which have been considered:

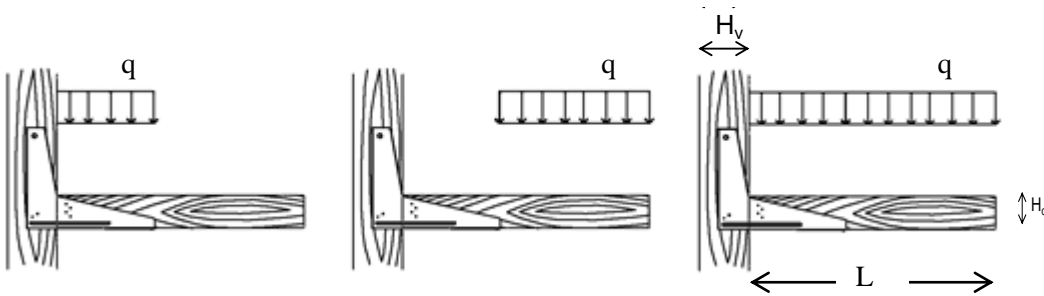

Figure: MAXIMUS possible load distributions

**Modified characteristic capacity:**

The strength and stiffness values determined are directly applicable to timber of the strength class C24 and better with the following dimensions:

The horizontal cantilevered timber member: Depth  $H_c = 160$  mm ; Width B as vertical member (column)

The vertical member: Depth  $H_v = 220$  mm<sup>1)</sup> for  $B < 139$  mm

$220 \text{ mm}^1 \leq H_v \leq 340$  mm for  $139 \leq B < 159$  mm

1): These values may be reduced to 180 mm if only downward forces can occur.

Higher depths  $H_v$  can be tolerated if a splitting reinforcement designed for at least  $F_k = 8,8 \text{ kN}$  is applied near the dowel. If the width  $B$  is smaller than 120 mm the characteristic load-carrying capacity can be determined by applying a factor  $B/120 \text{ mm}$  to the capacities listed in table D50-1.

The characteristic load-carrying capacity  $q_{R,k}$  for a cantilever with a length  $L = 1200 \text{ mm}$  is listed in the table D50-1 below. The common types of distributed loads have been evaluated also considering the possible positions of distributed loads shown in the figure D50-3.

**Table D50-1 Characteristic capacity timber beam to column – 1 MAXIMUS**

Load duration	Spring stiffness* $C_\phi$ of the connection for a downward force (kNm)	Characteristic distributed load capacity $q_{R,k}$ per connector (kN/m) and a lever arm $L=1200\text{mm}$	
		downward	uplift
P	43	7,02	-2,60
L	43		
M	48		
S	67		
I	85		

<sup>1)</sup> $C_\phi$  shall be reduced to 60% of these values if the timber moisture exceeds 18% for longer term

## Annex D51 – AT2

### Product Name:

Product Name	Material reference acc. to clause II-1	Alternative product names
AT2	Steel ref. 1	-
AT2S	Steel ref. 2	-
AT2S2	Steel ref. 3	-

### Connector Size Range:

Model no.	Dimensions [mm]				Holes flange A		Holes flange B	
	A	B	C	Thickness	Ø5	Ø9 x 17	Ø5	Ø10
AT2	53	53	103	1,0	4	1	6	1

### Drawing:

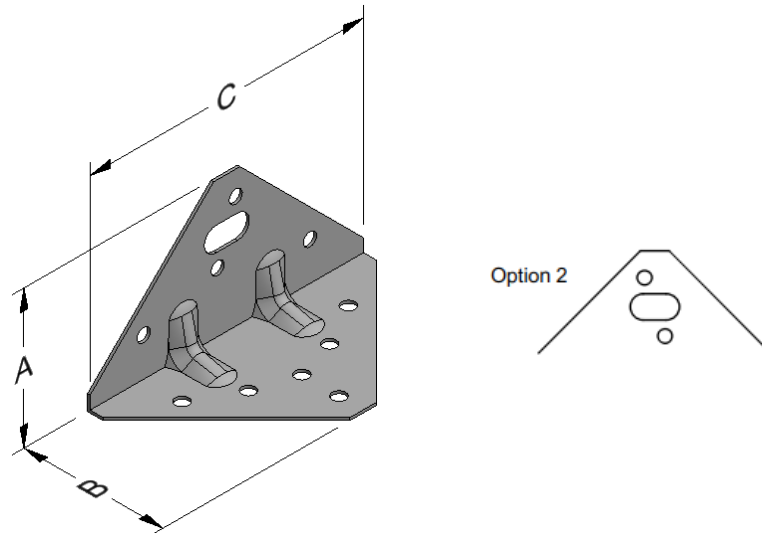

### Nailing pattern:

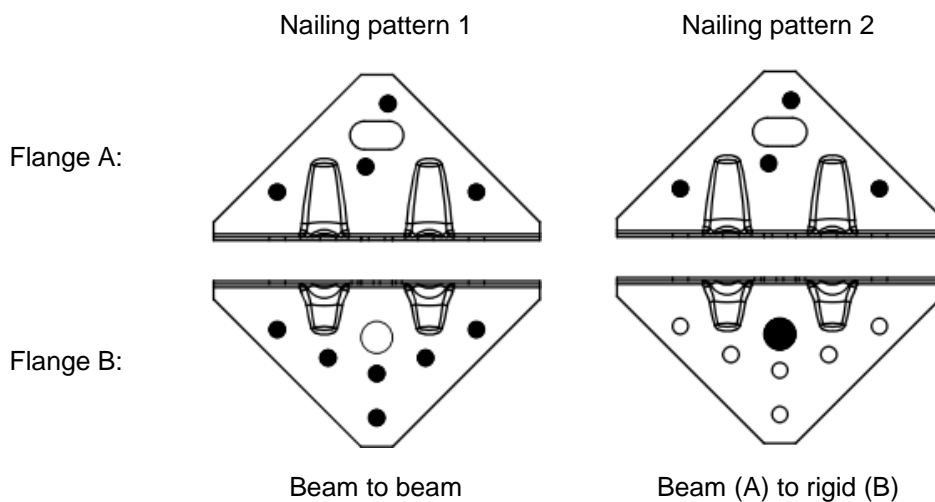

*Table D51-1 Characteristic capacity timber beam to timber beam – 2 Angle Brackets*

2 Angle Brackets AT2 per connection			Characteristic capacity per connection (kN)	
Nailing pattern	Number of nails		$R_{1,k}$	$R_{2/3,k}$
	Flange A	Flange B	CNA Connector nail	
			4,0x35	4,0x35
Nailing pattern 1	4	6	5,3	11,1

*Table D51-2 Characteristic capacity timber beam to rigid – 2 Angle Brackets*

2 Angle Brackets AT2 per connection			Characteristic capacity per connection (kN)	
Nailing pattern	Number of nails		$R_{1,k}$	$R_{2/3,k}$
	Flange A	Flange B	CNA Connector nail	
			4,0x35	4,0x35
Nailing pattern 2	4	1 x Ø8 Bolt	4,5	8,0

2 Angle Brackets AT2 per connection				
factor for:	$F_1$	$F_{2/3}$	$F_{4/5,bolt 1}$	$F_{4/5,bolt 2}$
$k_{ax}$	0,62	0,35	-	-
$k_{lat}$	-	0,50	-	-

For each bolt it's needed to check:  $R_{bolt,d,lateral} \geq k_{lat} \times F_{i,d}$  ;  $R_{bolt,d,axial} \geq k_{ax} \times F_{i,d}$ ; and also the combination.

## Annex D52 – ABR865

### Product Name:

Product Name	Material reference acc. to clause II-1	Alternative product names
ABR865	Steel ref. 1	-
ABR865S	Steel ref. 2	-
ABR865S2	Steel ref. 3	-

### Connector Size Range:

Model no.	Dimensions [mm]				Holes flange A	Holes flange B
	A	B	C	Thickness	Ø9	Ø9
ABR865	65	80	145	3,0	3	3

### Drawing:

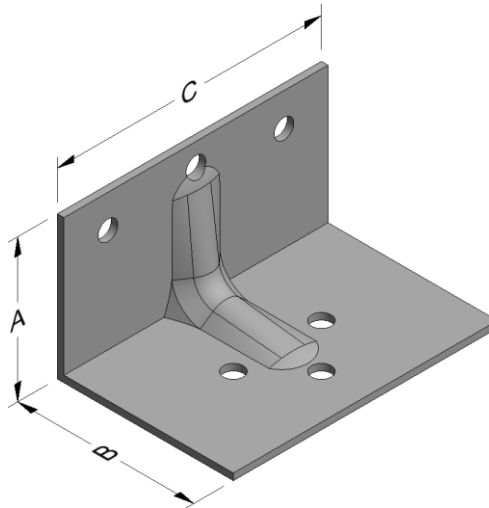

### Nailing pattern:

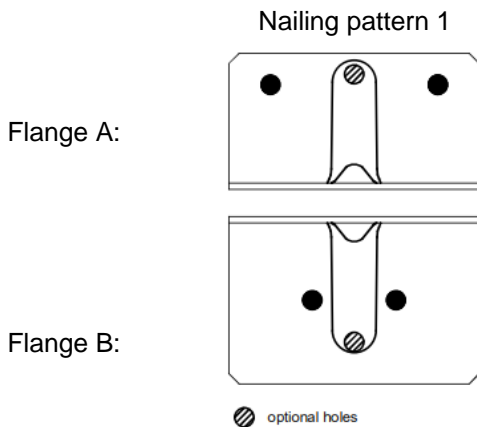

Timber to Timber  
(The optional holes are only for constructive using.)

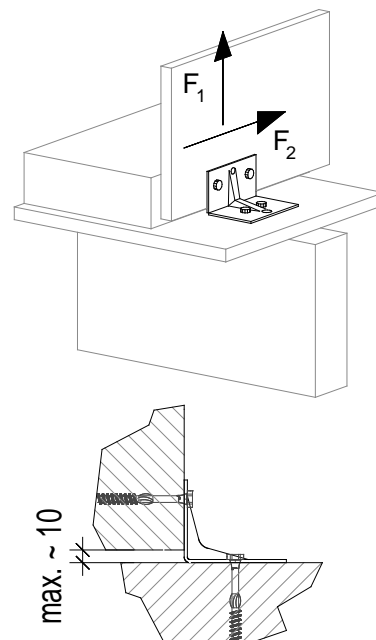



The connected elements shall be free of twisting, so that no rotation occurs.

The flanges of the ABR865 have to be bear full-faced, for the vertical flange is a gap up to 10 mm allowed.

**Table D52-1 Characteristic capacity timber to timber, Load direction F1 – 1 Angle Bracket**

1 Angle Bracket ABR865 per connection		Characteristic capacity per connection (kN) with 8,0x120 mm ASSY Kombi 3.0 Screw										
		$R_{1,k} = \min[\text{table value}; 8,48/k_{\text{mod}}]$										
Nailing pattern	Screw characteristics	Screw: $R_{\text{lat},k}$ (kN)										
	Screw: $R_{\text{ax},k}$ (kN)	4	4,5	5	5	6	6,5	7	7,5	8	8,5	9
Nailing pattern 1 Flange A: 2 Flange B: 2	4	5,9	6,1	6,1	6,1	6,1	6,1	6,1	6,1	6,1	6,1	6,1
	4,5	6,2	6,7	6,8	6,8	6,8	6,8	6,8	6,8	6,8	6,8	6,8
	5	6,5	7,0	7,4	7,6	7,6	7,6	7,6	7,6	7,6	7,6	7,6
	5,5	6,7	7,2	7,7	8,1	8,4	8,4	8,4	8,4	8,4	8,4	8,4
	6	6,8	7,4	8,0	8,5	8,9	9,1	9,1	9,1	9,1	9,1	9,1
	6,5	7,0	7,6	8,2	8,7	9,2	9,6	9,9	9,9	9,9	9,9	9,9
	7	7,1	7,8	8,4	9,0	9,5	9,9	10,4	10,6	10,6	10,6	10,6
	7,5	7,2	7,9	8,6	9,2	9,7	10,2	10,7	11,1	11,4	11,4	11,4
	8	7,3	8,0	8,7	9,3	9,9	10,5	11,0	11,4	11,8	12,2	12,2
	8,5	7,4	8,1	8,8	9,5	10,1	10,7	11,2	11,7	12,2	12,6	12,9
	9	7,4	8,2	8,9	9,6	10,3	10,9	11,4	12,0	12,4	12,9	13,3
	9,5	7,5	8,3	9,0	9,7	10,4	11,0	11,6	12,2	12,7	13,2	
	10	7,5	8,3	9,1	9,8	10,5	11,2	11,8	12,4	12,9	13,5	
	10,5	7,6	8,4	9,2	9,9	10,6	11,3	12,0	12,6	13,2	13,7	

**Table D52-2 Characteristic capacity timber to timber, Load direction F2 – 1 Angle Bracket**

1 Angle Bracket ABR865 per connection		Characteristic capacity per connection (kN) with 8,0x120 mm ASSY Kombi 3.0 Screw										
		$R_{2,k}$										
Nailing pattern	Screw characteristics	Screw: $R_{\text{lat},k}$ (kN)										
	Screw: $R_{\text{ax},k}$ (kN)	4	4,5	5	5	6	6,5	7	7,5	8	8,5	9
Nailing pattern 1 Flange A: 2 Flange B: 2	4	5,96	6,51	7,01	7,47	7,88	8,25	8,25	8,25	8,25	8,3	8,3
	4,5	6,11	6,71	7,26	7,77	8,23	8,25					
	5	6,23	6,86	7,45	8,01	8,25						
	5,5	6,32	6,98	7,61	8,20							
	6	6,39	7,07	7,73	8,25							
	6,5	6,44	7,15	7,83								
	7	6,49	7,21	7,91								
	7,5	6,53	7,27	7,98								
	8	6,56	7,31	8,04								
	8,5	6,58	7,35	8,09								
	9	6,61	7,38	8,13								
	9,5	6,63	7,40	8,17								
	10	6,64	7,43	8,20								
	10,5	6,66	7,45	8,22								

The tables are based on the characteristic capacities of the used screws with  $R_{\text{lat},k}$  for the lateral (shear) capacity and  $R_{\text{ax},k}$  for the axial (tension) capacity.

For blank cells are no higher values given as the last filled cell before in the same column.

The values for characteristic capacities of the fastener with  $R_{\text{lat},k}=4,75$  kN and  $R_{\text{ax},k}=7,04$  kN are for connection as described following with using screws 8,0x120 ASSY Kombi 3.0 according to ETA 11/0190:

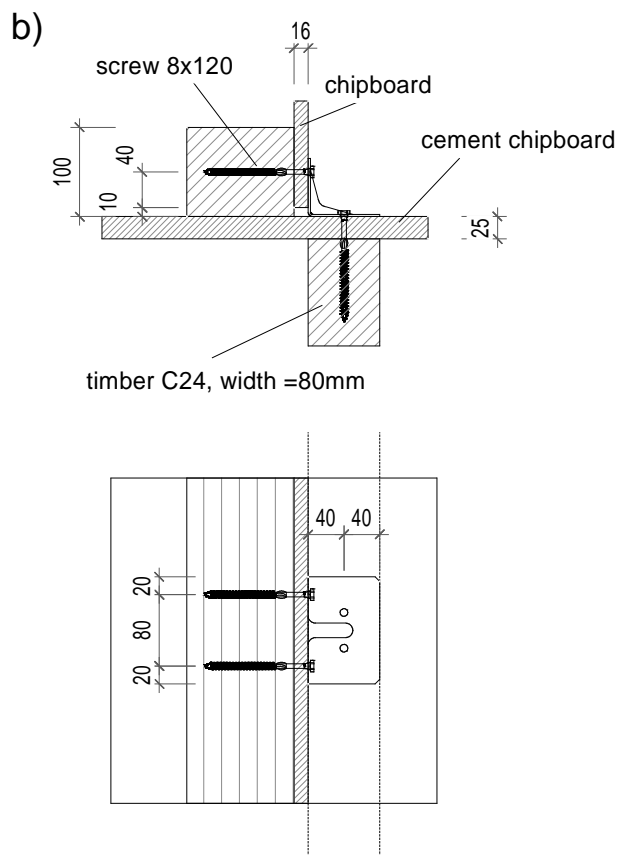
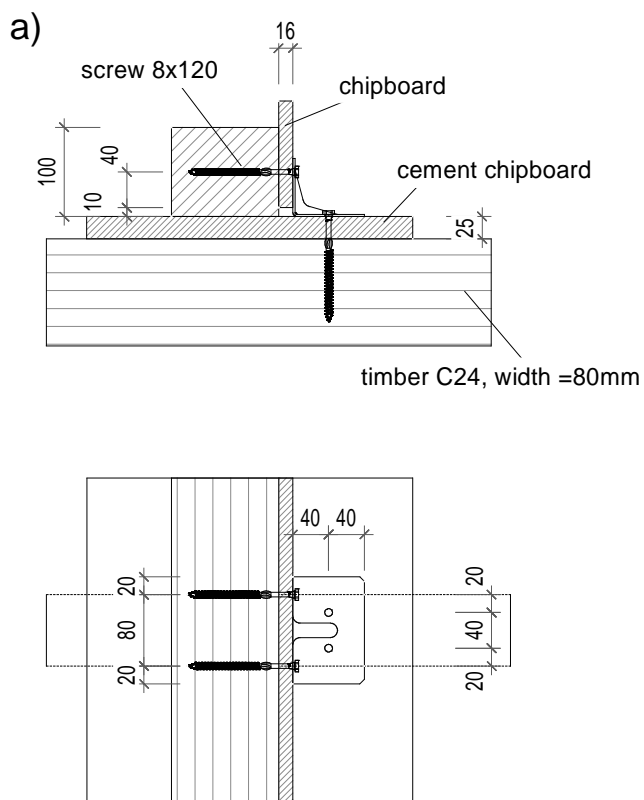

Chipboard class P4 according to EN 13986.

Cement-bonded particleboard (in drawings named cement chipboard) according to EN 13986.

Both layers are connected shear fixed with the timber.

## Annex D53 – ACFET200 & ACFET200PP

### Product Name:

Product Name	Material reference acc. to clause II-1	Alternative product names
ACFET200	Steel ref. 1	-
ACFET200PP	Steel ref. 1	-
ACFET200S	Steel ref. 2	-
ACFET200PPS	Steel ref. 2	-
ACFET200S2	Steel ref. 3	-
ACFET200PPS2	Steel ref. 3	-

### Connector Size Range:

Model no.	Dimensions [mm]				Holes flange A	Holes flange B
	A	B	C	Thickness	Ø12	Ø5
ACFET200	49	100	200	4,0	1	5
ACFET200PP	78	102	200	4,0	1	5

### Drawing:

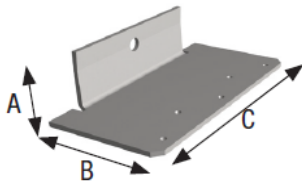

ACFET200

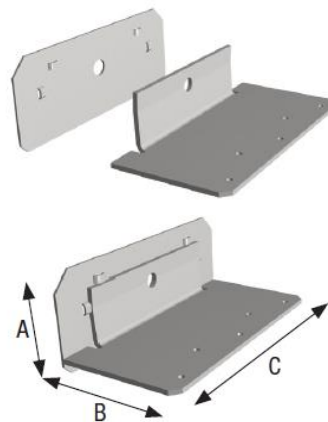

ACFET200PP

Table D53-1 Characteristic capacity timber to rigid – 1 Angle Bracket

1 Angle Bracket ACFET200 or ACFET200PP	Characteristic capacity per connection (kN)	Vertical displacement (mm)
Nailing		
1 M10 Concrete Screw/Bolt	$G_k = 185 \text{ kNmm} / (e-5 \text{ mm})$	$u_{init} = G \times (e-5 \text{ mm})^2 / 2400$

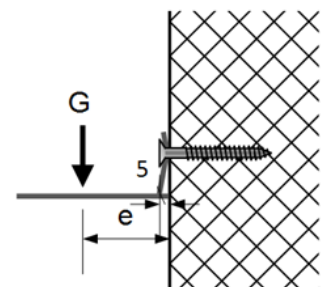

The concrete screw/bolt is subjected to a shear force of  $F_{v,k} = G_k$  and a tension force of  $F_{ax,k} = G_k \cdot e / 30$

## Annex D54 – ANP

### Product Name:

Product Name	Material reference acc. to clause II-1	Alternative product names
ANP----	Steel ref. 1	-
ANP----S	Steel ref. 2	-
ANP----S2	Steel ref. 3	-

### Connector Size Range:

Model no.	Dimensions [mm]				Holes flange A	Holes flange B
	A	B	C	Thickness	Ø5	Ø5
ANP 25 10 10 100	100	100	100	2,5	23	23
ANP 25 10 10 80	100	100	80	2,5	18	18
ANP 25 10 10 60	100	100	60	2,5	13	13
ANP 25 8 8 100	80	80	100	2,5	18	18
ANP 25 8 8 80	80	80	80	2,5	14	14
ANP 25 8 8 60	80	80	60	2,5	10	10
ANP 25 6 6 100	60	60	100	2,5	14	14
ANP 25 6 6 80	60	60	80	2,5	11	11
ANP 25 6 6 60	60	60	60	2,5	8	8
ANP 25 6 6 50	60	60	50	2,5	6	6
ANP 25 10 20 100	100	200	100	2,5	45	23
ANP 25 6 10 60	60	100	60	2,5	12	8
ANP 25 4 6 60	40	60	60	2,5	7	5

### Drawing:

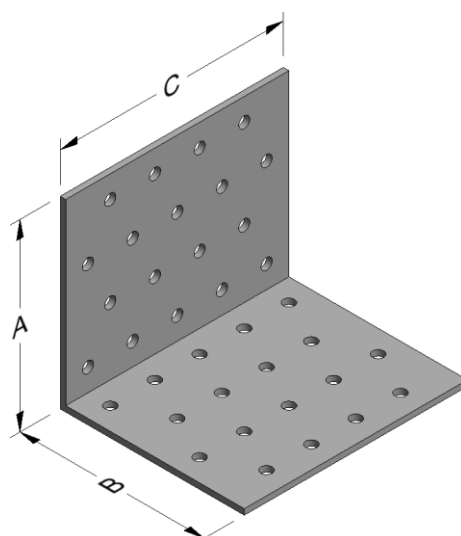

**Nailing pattern:**

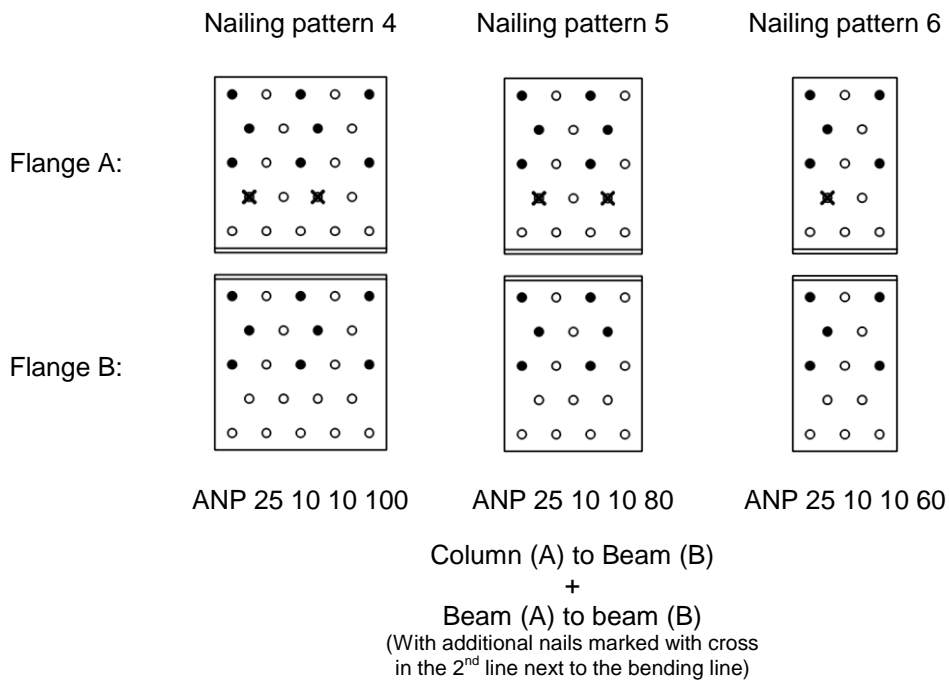
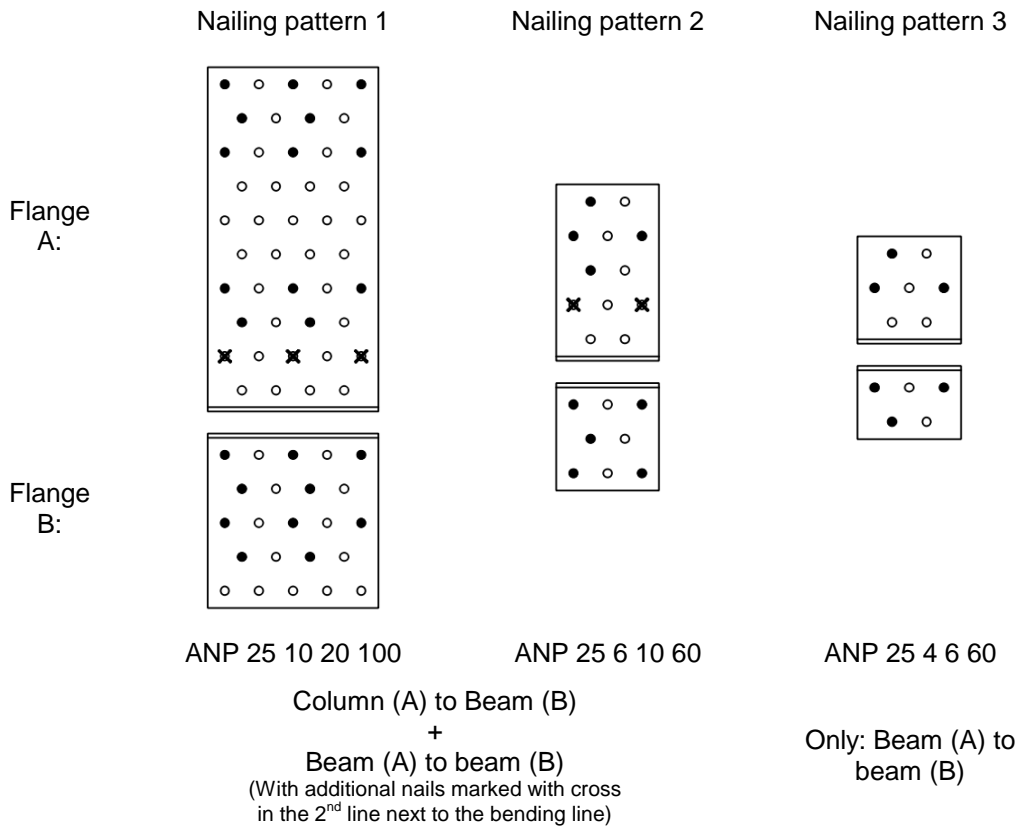

Nailing pattern 7

Nailing pattern 8

Nailing pattern 9

Flange A:

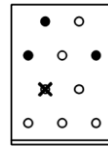
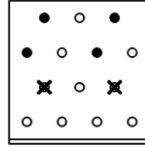
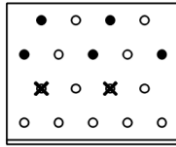

Flange B:

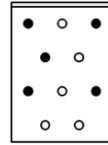
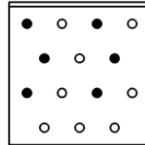
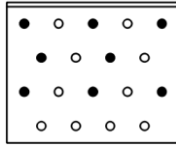

ANP 25 8 8 100

ANP 25 8 8 80

ANP 25 8 8 60

Column (A) to Beam (B)  
+  
Beam (A) to beam (B)  
(With additional nails marked with cross  
in the 2<sup>nd</sup> line next to the bending line)

Nailing pattern 10

Nailing pattern 11

Nailing pattern 12

Nailing pattern 13

Flange A:

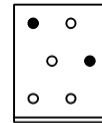
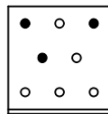
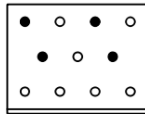
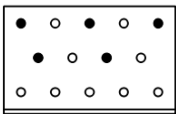

Flange B:

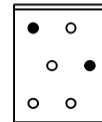
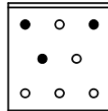
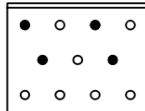
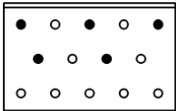

ANP 25 6 6 100

ANP 25 6 6 80

ANP 25 6 6 60

ANP 25 6 6 50

Beam (A) to Beam (B)

Info: ANP 25 6 6 40 no values have been determined for this reference because of the minor nail distances.

**Table D54-1** Characteristic capacity timber column to timber beam – 2 Angle Brackets

2 Angle Brackets ANP per connection				Characteristic capacity per connection (kN)					
Model No.	Nailing pattern	Number of Fasteners		R <sub>1,k</sub>			R <sub>2/3,k</sub>		
		Flange A (Column)	Flange B (Beam)	CNA 4.0x40	CNA 4.0x50	CNA 4.0x60	CNA 4.0x40	CNA 4.0x50	CNA 4.0x60
ANP 25 10 10 100	Nailing pattern 4	8	8	6,48	8,3	9,64	9,56	11,8	12,96
ANP 25 10 10 80	Nailing pattern 5	6	6	5,46	6,5	7,16	5,96	7,38	8,16
ANP 25 10 10 60	Nailing pattern 6	5	5	3,88	4,96	6,04	4,9	6,06	6,68
ANP 25 8 8 100	Nailing pattern 7	5	8	6,44	8,14	9,74	7,26	8,9	9,66
ANP 25 8 8 80	Nailing pattern 8	4	6	5,34	6,6	7,26	5,14	6,42	7,02
ANP 25 8 8 60	Nailing pattern 9	3	5	3,88	4,9	5,92	3,16	3,88	4,22
ANP 25 10 20 100	Nailing pattern 1	13	10	7,18	9,56	11,96	11,2	13,74	14,92
ANP 25 6 10 60	Nailing pattern 2	4	5	3,94	5,26	6,58	3,08	3,78	4,1

**Table D54-2** Characteristic capacity timber beam to timber beam – 2 Angle Bracket

2 Angle Brackets ANP per connection				Characteristic capacity per connection (kN)					
Model No.	Nailing pattern	Number of Fasteners		R <sub>1,k</sub>			R <sub>2/3,k</sub>		
		Flange A (Beam)	Flange B (Beam)	CNA 4.0x40	CNA 4.0x50	CNA 4.0x60	CNA 4.0x40	CNA 4.0x50	CNA 4.0x60
ANP 25 10 10 100	Nailing pattern 4	10	8	6,48	8,3	9,64	11,02	13,64	15
ANP 25 10 10 80	Nailing pattern 5	8	6	5,46	6,5	7,16	7,76	9,64	10,6
ANP 25 10 10 60	Nailing pattern 6	6	5	3,88	4,96	6,04	5,86	7,22	7,88
ANP 25 8 8 100	Nailing pattern 7	7	8	6,44	8,14	9,74	9,2	11,46	12,7
ANP 25 8 8 80	Nailing pattern 8	6	6	5,34	6,6	7,26	7,28	8,98	9,9
ANP 25 8 8 60	Nailing pattern 9	4	5	3,88	4,9	5,92	3,96	4,94	5,54
ANP 25 6 6 100	Nailing pattern 10	5	5	5,9	7,84	9,26	7,96	9,94	11,06
ANP 25 6 6 80	Nailing pattern 11	4	4	5,12	6,28	7,42	6,02	7,5	8,42
ANP 25 6 6 60	Nailing pattern 12	3	3	3,6	4,8	5,7	3,38	4,2	4,68
ANP 25 6 6 50	Nailing pattern 13	2	2	2,82	3,4	3,96	2,88	3,58	3,96
ANP 25 10 20 100	Nailing pattern 1	16	10	7,18	9,56	11,96	13,14	16,14	17,52
ANP 25 6 10 60	Nailing pattern 2	6	5	3,94	5,26	6,58	5,74	7,1	7,7
ANP 25 4 6 60	Nailing pattern 3	3	3	3,48	4,64	5,8	3,74	4,68	5,32

## Annex D55 – A-brackets

### Product Name:

Product Name	Material reference acc. to clause II-1	Alternative product names
A21	Steel ref. 4, G90	-
A23	Steel ref. 4, G90	-
A33	Steel ref. 4, G90	-
A88	Steel ref. 4, G90	-
A21S	Steel ref. 2	-
A23S	Steel ref. 2	-
A33S	Steel ref. 2	-
A88S	Steel ref. 2	-
A21S2	Steel ref. 3	-
A23S2	Steel ref. 3	-
A33S2	Steel ref. 3	-
A88S2	Steel ref. 3	-

### Connector Size Range:

Model no.	Dimensions [mm]				Holes flange A			Holes flange B		
	A	B	C	Thickness	Ø4	Ø4,34	Ø11,1	Ø4	Ø4,34	Ø11,1
A21	38	50,8	35	1,2	-	2	-	-	2	-
A23	38	50,8	70	1,2	-	4	-	-	4	-
A33	74,6	77,8	38	2,5	4	-	-	4	-	-
A88	203,2	203,2	51	2,5	4	-	3	4	-	3

### Drawing:

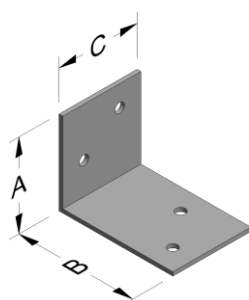

A21

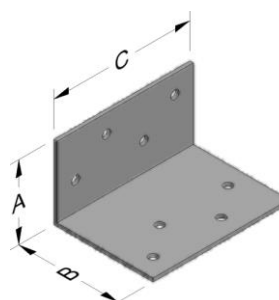

A23



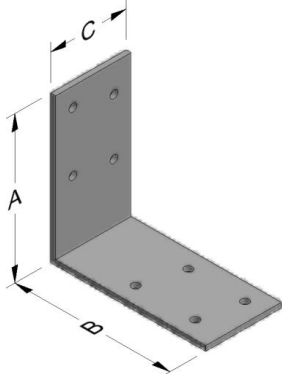

A33

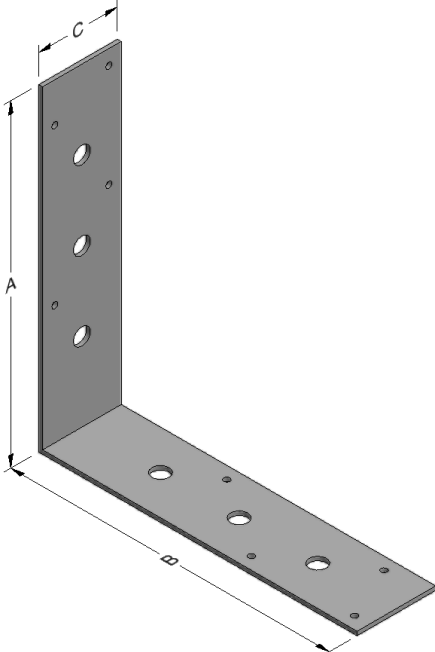

A88

**Nailing pattern:**

Nailing pattern 1

Nailing pattern 2

Nailing pattern 3

Nailing pattern 4

Flange A:

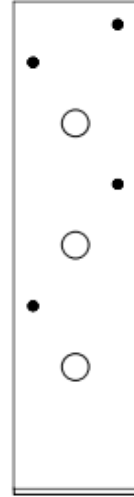
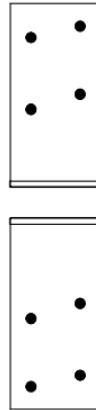
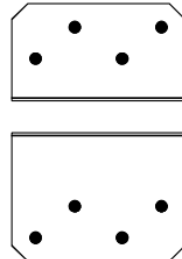

Flange B:

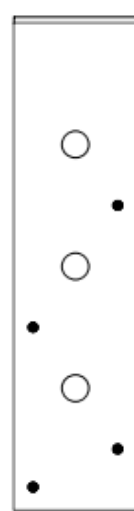
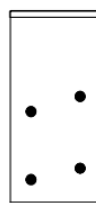
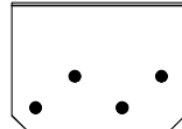

A21

A23

A33

A88

Beam to beam or  
Column to beam  
Full nailing

Beam to beam or  
Column to beam  
Full nailing

Beam to beam or  
Column to beam  
Full nailing

Beam to beam or  
Column to beam  
Full nailing

**Characteristic Capacities under vertically upward load (F<sub>1</sub>)**

For the types **A21** and **A23** the following formula needs to be used:  
Therefore the values R<sub>1,k</sub> are stated in the table below.

$$R_{1,d} = R_{1,k} \times \frac{k_{\text{mod}}}{1,3}$$

For the types **A33** and **A88** the following formula needs to be used:  
The values R<sub>1,k</sub> + power + R<sub>k,steel</sub> are stated in Table D55-1 below.

$$R_{1,d} = \min \left( \frac{R_{1,k}}{(k_{\text{mod}})^{\text{power}}} \times \frac{k_{\text{mod}}}{1,3}; \frac{R_{k,\text{steel}}}{1,3} \right)$$

**Characteristic Capacities under horizontal load (F<sub>2/3</sub>)**

For F<sub>2/3</sub>-horizontal force the following formula needs to be used:  
The values R<sub>2/3,k</sub> are stated in Table D55-1 below.

$$R_{2/3,d} = R_{2/3,k} \times \frac{k_{\text{mod}}}{1,3}$$

**Characteristic Capacities under horizontal load (F<sub>4/5</sub>)**

For F<sub>4/5</sub>-horizontal force the following formula needs to be used:  
The values for R<sub>4/5,k</sub> connected with 2 angle brackets and for R<sub>4,k</sub> / R<sub>5,k</sub> connected with 1 angle bracket are stated in Table D55-1 below.  
Supported Member with a minimum width b<sub>t</sub>=60mm.  
The load capacities R<sub>4,k</sub> are split in two; with and without rotation of purlin.

$$R_{4/5,d} = R_{4/5,k} \times \frac{k_{\text{mod}}}{1,3}$$

*Table D55-1 Characteristic capacity timber beam to timber beam or timber column to timber beam – 1 Angle Bracket*

1 Angle Bracket A with min b <sub>t</sub> = 60 mm per connection				Characteristic capacity per connection (kN)					
Model No.	Nailing pattern	Number of Fasteners		R <sub>1,k</sub> <sup>1)</sup>			R <sub>k,steel</sub>	R <sub>2/3,k</sub> <sup>1)</sup>	
		Flange A	Flange B	N3.75x30	N3.75x75 <sup>2)</sup>	Power		N3.75x30	N3.75x75
A21	Nailing pattern 1	2	2	0,24	-	-	-	0,35	-
A23	Nailing pattern 2	4	4	0,48	-	-	-	1,09	-
A33	Nailing pattern 3	4	4	-	1,15	0,25	1,04	-	2,30
A88	Nailing pattern 4	4	4	-	0,57	1	0,57	-	2,16

<sup>1)</sup> Characteristic Capacities have been determined in accordance with EN14358 and are based on C24 timber

<sup>2)</sup> The Characteristic Capacities R<sub>1,k</sub> and R<sub>4/5,k</sub> connected with smooth shank nails N3.75x75 shall only be used for short load durations!

**Table D55-2 Characteristic capacity timber beam to timber beam or timber column to timber beam – 1 Angle Bracket**

1 Angle Bracket A with min $b_t = 60$ mm per connection				Characteristic capacity per connection (kN)									
Model No.	Nailing pattern	Number of Fasteners		$R_{4,k}^{1)}$						$R_{5,k}^{1)}$			
		Flange A	Flange B	N3.75x30			N3.75x75 <sup>2)</sup>			N3.75x30		N3.75x75 <sup>2)</sup>	
				e (mm)	with rotation	without rotation	e (mm)	with rotation	without rotation	e (mm)	(kN)	e (mm)	(kN)
A21	Nailing pattern 1	2	2	50	$0.066 / k_{mod}$	0,92	-	-	-	50	0,23	-	-
				100	$0.033 / k_{mod}$					100	0,13		
				150	$0.022 / k_{mod}$					150	0,08		
A23	Nailing pattern 2	4	4	50	$0.131 / k_{mod}$	1,70	-	-	-	50	0,46	-	-
				100	$0.066 / k_{mod}$					100	0,25		
				150	$0.044 / k_{mod}$					150	0,17		
A33	Nailing pattern 3	4	4	-	-	-	50	$0.28 / k_{mod}$	2,00	-	-	50	$1.0 / k_{mod}^{0.5}$
							100	$0.14 / k_{mod}$				100	0,70
							150	$0.10 / k_{mod}$				150	0,47
A88	Nailing pattern 4	4	4	-	-	-	50	0,34	2,60	-	-	50	$0.57 / k_{mod}$
							100	$0.20 / k_{mod}$				100	$0.55 / k_{mod}^{0.5}$
							150	$0.13 / k_{mod}$				150	0,47

<sup>1)</sup> Characteristic Capacities have been determined in accordance with EN14358 and are based on C24 timber

<sup>2)</sup> The Characteristic Capacities  $R_{1,k}$  and  $R_{4/5,k}$  connected with smooth shank nails N3.75x75 shall only be used for short load durations!

**Table D55-3 Characteristic capacity timber beam to timber beam or timber column to timber beam – 2 Angle Brackets**

2 Angle Brackets A per connection				Characteristic capacity per connection (kN)			
Model No.	Nailing pattern	Number of Fasteners		$R_{4/5,k}^{1)}$			
		Flange A	Flange B	N3.75x30		N3.75x75 <sup>2)</sup>	
				e (mm)	(kN)	e (mm)	(kN)
A21	Nailing pattern 1	2	2	50	1,15	-	-
				100	1,05		
				150	1,00		
A23	Nailing pattern 2	4	4	50	2,15	-	-
				100	1,95		
				150	1,85		
A33	Nailing pattern 3	4	4	-	-	50	2,95
						100	2,70
						150	2,47
A88	Nailing pattern 4	4	4	-	-	50	3,20
						100	3,15
						150	3,10

<sup>1)</sup> Characteristic Capacities have been determined in accordance with EN14358 and are based on C24 timber

<sup>2)</sup> The Characteristic Capacities  $R_{1,k}$  and  $R_{4/5,k}$  connected with smooth shank nails N3.75x75 shall only be used for short load durations!

## Annex D56 – ABR98 & ABRL98

### Product Name:

Product Name	Material reference acc. to clause II-1	Alternative product names
ABR98	Steel ref. 1	-
ABRL98	Steel ref. 1	-
ABR98S	Steel ref. 2	-
ABRL98S	Steel ref. 2	-
ABR98S2	Steel ref. 3	-
ABRL98S2	Steel ref. 3	-

### Connector Size Range:

Model no.	Dimensions [mm]				Holes flange A			Holes flange B	
	A	B	C	Thickness	Ø5	Ø13	Oblong 40x13	Ø5	Ø13
ABR98	98	98	88	3,0	10	3	0	12	3
ABRL98	98	98	88	3,0	10	2	1	12	3

### Drawings:

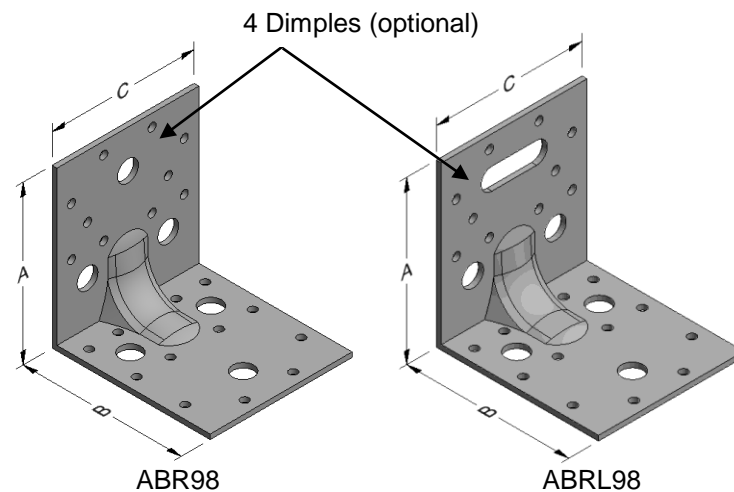

### Nailing pattern:

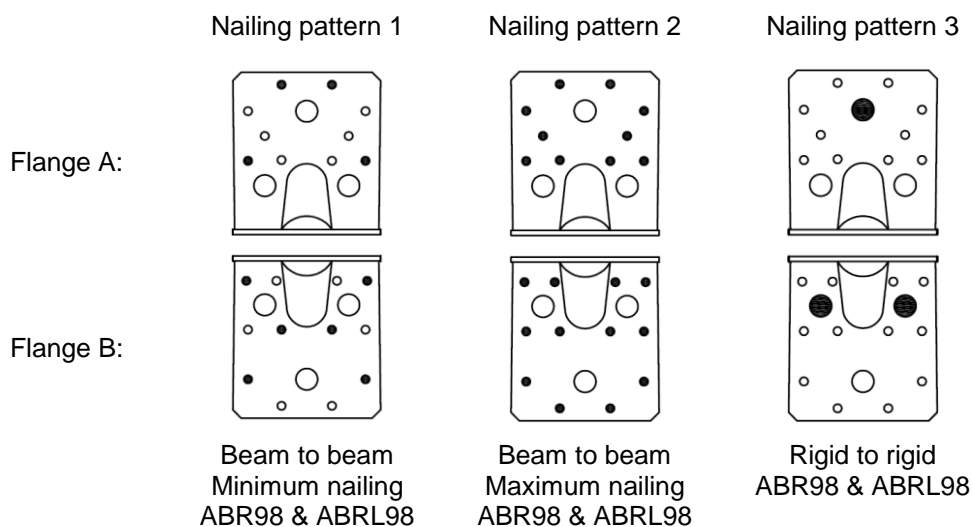

**Table D56-1 Characteristic capacity beam to beam – 2 Angle Brackets**

2 Angle Brackets ABR98 or ABRL98 per connection			Characteristic capacity (kN) per connection												
			F <sub>1,k</sub>				F <sub>2/3,k</sub>				F <sub>4/5,k</sub> <sup>1)</sup>				
Nailing pattern	Number of fasteners		CNA Connector Nail 4,0 x ℓ												
	Flange A	Flange B	35	40	50	60	35	40	50	60	e (mm)	35	40	50	60
Nailing pattern 1	4	6	5,9	7	9	10,8	6	6,9	8,8	9,7	50	11,2	12,5	14,2	14,7
											100	10,6	11,8	13,3	13,6
											150	10,4	11,5	12,9	13,1
Nailing pattern 2	10	12	9,8	11,8	15,7	19,7	12,1	13,7	17,5	19,8	50	14,9	15,5	16,5	17,1
											100	13,6	13,9	14,4	14,9
											150	13,1	13,3	13,7	14

1) Minimum width of timber member b<sub>t</sub> = 60 mm

Regarding F<sub>2/3</sub> – other fasteners may be used using the following formula and factors. Alternatively, the values from above table can be reduced accordingly:

$$R_{2/3,k} = \min \left\{ \sqrt{\frac{1}{\left(\frac{1}{k_{lat,v} \times R_{lat,k}}\right)^2 + \left(\frac{1}{k_{ax,v} \times R_{ax,k}}\right)^2}}, \sqrt{\frac{1}{\left(\frac{1}{k_{lat,h} \times R_{lat,k}}\right)^2 + \left(\frac{1}{k_{ax,h} \times R_{ax,k}}\right)^2}} \right.$$

Factor	Nailing pattern 1	Nailing pattern 2
k <sub>lat,v</sub>	2,1	4,3
k <sub>ax,v</sub>	41,3	30,7
k <sub>lat,h</sub>	2,9	5,4
k <sub>ax,h</sub>	6,2	13,3

**Table D56-2: Characteristic capacity timber beam to rigid support – 2 Angle Brackets**

2 Angle Brackets ABR98 or ABRL98 per connection			Characteristic capacity (kN) per connection
Nailing pattern	Number of fasteners		R <sub>1,k</sub>
	Flange A	Flange B	
Nailing pattern 3	1 M12 Bolt	2 M12 Bolts <sup>2)</sup>	17,3 <sup>1)</sup>

1) k<sub>mod</sub> = 1,0 for all load durations.

2) For each bolt it must be checked that: R<sub>bolt,ax,d</sub> ≥ 0,5 x F<sub>1,d</sub>

## Annex D57 – AB105/513

### Product Name:

Product Name	Material reference acc. to clause II-1	Alternative product names
AB105/513	Steel ref. 1	-
AB105/513S	Steel ref. 2	-
AB105/513S2	Steel ref. 3	-

### Connector Size Range:

Model no.	Dimensions [mm]				Holes flange A		Holes flange B	
	A	B	C	Thickness	Ø5	Ø13	Ø5	Ø13
AB105/513	105	105	90	3,0	14	3	14	2

### Drawing:

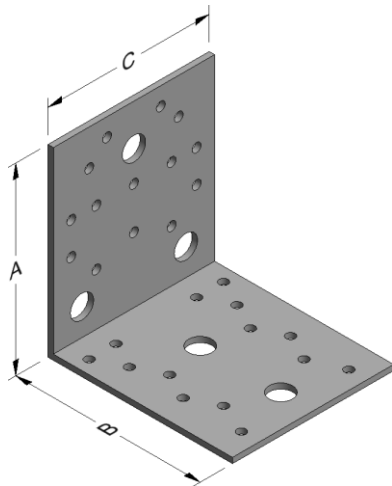

AB105/513

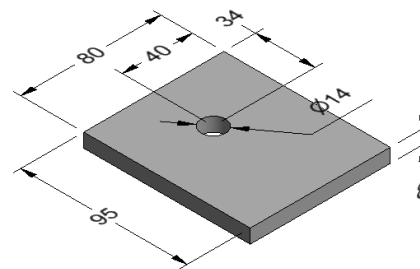

Washer

### Nailing pattern:

#### Nailing pattern 1

Flange A:

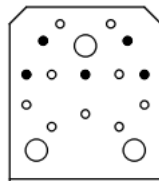

Flange B:

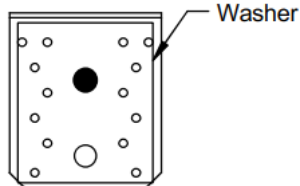

Beam (A) to rigid (B)

**Table D57-1 Characteristic capacity timber beam to rigid – 1 Angle Bracket**

1 Angle Bracket ABR105/513 per connection				Characteristic capacity per connection (kN)	
Nailing pattern	Number of Fasteners		Installation	$R_{1,k}$	
	Flange A	Flange B		CNA4,0x1 or CSA5,0x1	
				min. of	
Nailing pattern 1	5 nails Ø 4,0 or 5 CSA5,0 x 1	1 bolt Ø12mm	Normal <sup>1)</sup>	$n \times R_{lat,k}$	$10,1/k_{mod}$
			Special <sup>2)</sup>	$n \times R_{lat,k} \times 0,8$	$10,1/k_{mod}$

1) Normal = spacing of nails according to EN 1995-1-1

2) Special = spacing of nails according to figure below

The washer with  $t \geq 8$  mm has to fulfil the minimum requirement: steel with  $f_{y,k} \geq 235$  N/mm<sup>2</sup>

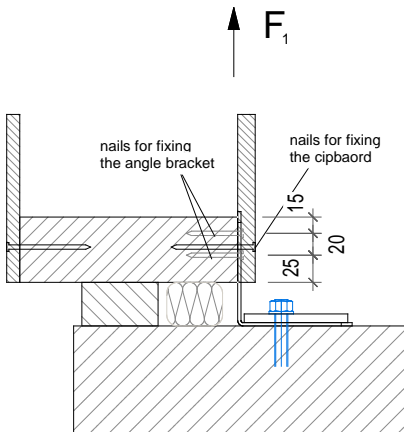

With:

$n =$  number of nails

$R_{lat,k} =$  characteristic lateral Load-carrying capacity of one connector nail / screw

It is to check additionally for the anchorage:  $R_{bolt,ax,d} \geq F_{1,d} \times 1,47$

With:

$R_{bolt,ax,d}$  = the axial design capacity of the anchor / bolt



## Annex D58 – ABR255

### Product Name:

Product Name	Material reference acc. to clause II-1	Alternative product names
ABR255	Steel ref. 1	-
ABR255S	Steel ref. 2	-
ABR255S2	Steel ref. 3	-

### Connector Size Range:

Model no.	Dimensions [mm]				Holes flange A		Holes flange B	
	A	B	C	Thickness	Ø5	Ø14	Ø5	Ø14
ABR255	120	100	255	3,0	52	2	41	4

### Drawing:

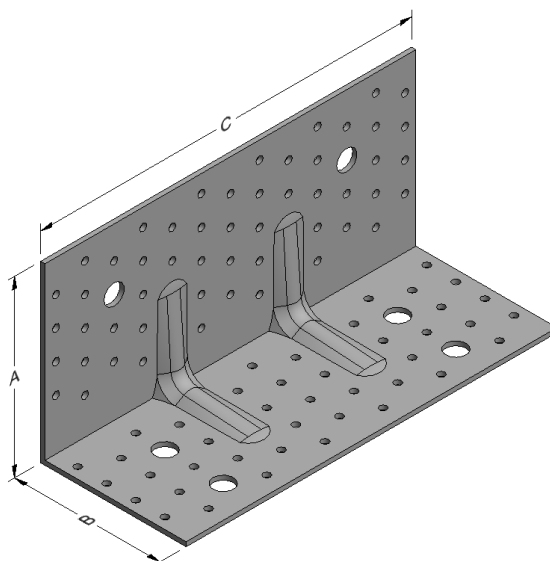

**Nailing pattern:**

Nailing pattern 1

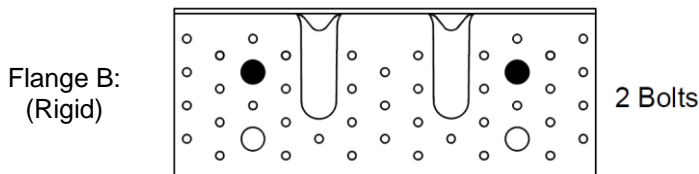
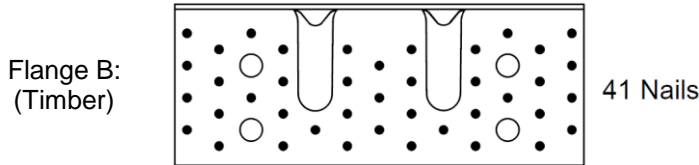
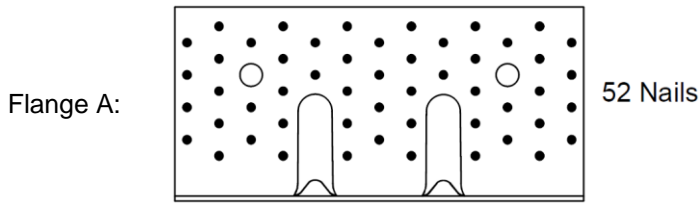

Beam (A) to Beam/Rigid (B)  
Maximum nailing

Nailing pattern 2

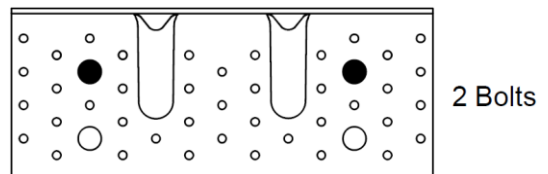
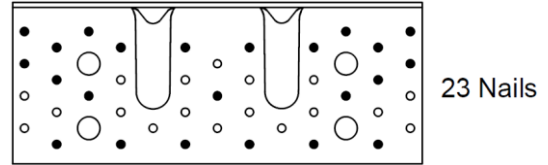
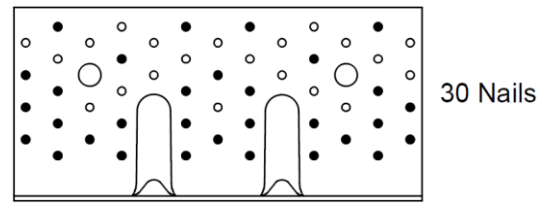

Beam (A) to Beam/Rigid (B)  
Minimum nailing

Nailing pattern 3

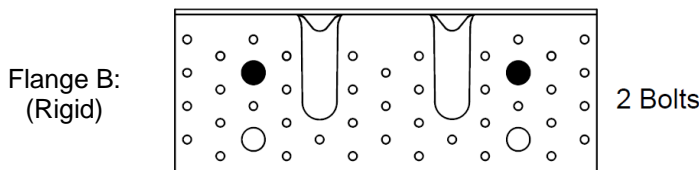
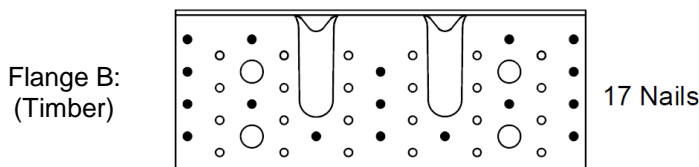
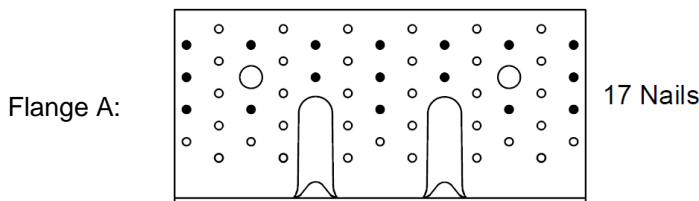

Column (A) to Beam/Rigid (B)  
Maximum nailing

**Characteristic Capacities:**

The values  $R_{i,k}$  for one ABR255 per connection, with prevention of rotation (so that only shear force is acting), are stated in the tables below.

For a connection with 2 x ABR255 the values can be doubled.

The following standard formula needs to be used:

$$R_{i,d} = R_{i,k} \times \frac{k_{mod}}{1,3}$$

*Table D58-1: Characteristic capacity beam to beam – 1 Angle Bracket  $F_1$*

1 Angle Bracket ABR255 per connection			Characteristic capacity (kN) per connection						
			$R_{1,k}$						
Nailing pattern	Number of fasteners		CNA Connector Nails				CSA Connector Screws		
	Flange A	Flange B	4,0x35	4,0x40	4,0x50	4,0x60	5,0x35	5,0x40	5,0x50
Nailing pattern 1	52	41	min of: 14,1/ $k_{mod}^{0,4}$ 23,6/ $k_{mod}$	min of: 16/ $k_{mod}^{0,4}$ 23,6/ $k_{mod}$	min of: 19,5/ $k_{mod}^{0,4}$ 23,6/ $k_{mod}$	min of: 22,5/ $k_{mod}^{0,4}$ 23,6/ $k_{mod}$	min of: 28/ $k_{mod}^{0,4}$ 23,6/ $k_{mod}$	min of: 34,5/ $k_{mod}^{0,4}$ 23,6/ $k_{mod}$	23,6/ $k_{mod}$
Nailing pattern 2	30	23	min of: 12,2/ $k_{mod}^{0,4}$ 23,6/ $k_{mod}$	min of: 13,7/ $k_{mod}^{0,4}$ 23,6/ $k_{mod}$	min of: 16,5/ $k_{mod}^{0,4}$ 23,6/ $k_{mod}$	min of: 19,5/ $k_{mod}^{0,4}$ 23,6/ $k_{mod}$	min of: 23,8/ $k_{mod}^{0,4}$ 23,6/ $k_{mod}$	min of: 28/ $k_{mod}^{0,4}$ 23,6/ $k_{mod}$	23,6/ $k_{mod}$
Nailing pattern 3	17	17	min of: 10,2/ $k_{mod}^{0,4}$ 26,2/ $k_{mod}$	min of: 11,2/ $k_{mod}^{0,4}$ 26,2/ $k_{mod}$	min of: 13,1/ $k_{mod}^{0,4}$ 26,2/ $k_{mod}$	min of: 15/ $k_{mod}^{0,4}$ 26,2/ $k_{mod}$	min of: 18,3/ $k_{mod}^{0,4}$ 26,2/ $k_{mod}$	min of: 22,3/ $k_{mod}^{0,4}$ 26,2/ $k_{mod}$	min of: 27,2/ $k_{mod}^{0,4}$ 26,2/ $k_{mod}$

*Table D58-2: Characteristic capacity beam to beam – 1 Angle Bracket  $F_{2/3}$*

1 Angle Bracket ABR255 per connection			Characteristic capacity (kN) per connection						
			$R_{2/3,k}$						
Nailing pattern	Number of fasteners		CNA Connector Nails				CSA Connector Screws		
	Flange A	Flange B	4,0x35	4,0x40	4,0x50	4,0x60	5,0x35	5,0x40	5,0x50
Nailing pattern 1	52	41	33,5	37,0	45,9	50,5	41,6	52,6	58,6
Nailing pattern 2	30	23	27,4	30,5	38,0	42,1	34,8	43,8	48,1
Nailing pattern 3	17	17	15,5	17,0	20,9	22,9	18,2	23,0	26,1

Table D58-3: Characteristic capacity beam to rigid support – 1 Angle Bracket  $F_1$ 

1 Angle Bracket ABR255 per connection			Characteristic capacity (kN) per connection						
			$R_{1,k}$						
Nailing pattern	Number of fasteners		CNA Connector Nails				CSA Connector Screws		
	Flange A	Flange B	4,0x35	4,0x40	4,0x50	4,0x60	5,0x35	5,0x40	5,0x50
Nailing pattern 1	52	2 x M12 Bolts	min of: 36,8 22/ $k_{mod}$	min of: 43,3 22/ $k_{mod}$	min of: 56,7 22/ $k_{mod}$	min of: 67,9 22/ $k_{mod}$	min of: 72,3 22/ $k_{mod}$	min of: 92,5 22/ $k_{mod}$	min of: 109,8 22/ $k_{mod}$
Nailing pattern 2	30	2 x M12 Bolts	min of: 15,94 22/ $k_{mod}$	min of: 18,8 22/ $k_{mod}$	min of: 24,8 22/ $k_{mod}$	min of: 30,3 22/ $k_{mod}$	min of: 35,1 22/ $k_{mod}$	min of: 45,2 22/ $k_{mod}$	min of: 56 22/ $k_{mod}$
Nailing pattern 3	17	2 x M12 Bolts	min of: 15,3 22/ $k_{mod}$	min of: 17,9 22/ $k_{mod}$	min of: 23,1 22/ $k_{mod}$	min of: 27 22/ $k_{mod}$	min of: 26,4 22/ $k_{mod}$	min of: 33,6 22/ $k_{mod}$	min of: 38,7 22/ $k_{mod}$

The bolts have to be checked for:  $F_{1,bolt,d} = R_{1,d} \times 1,1$

Table D58-4: Characteristic capacity beam to rigid support – 1 Angle Bracket  $F_{2/3}$  horizontal force

Table D58-4.1 - Optimized for Bolts

1 Angle Bracket ABR255 per connection			Characteristic capacity (kN) per connection						
			R <sub>2/3,k</sub> Optimized for Bolts *)						
Nailing pattern	Number of fasteners		CNA Connector Nails				CSA Connector Screws		
	Flange A	Flange B	4,0x35	4,0x40	4,0x50	4,0x60	5,0x35	5,0x40	5,0x50
Nailing pattern 1	52	2 x M12 Bolts	min of: 25,1 66,9/k <sub>mod</sub>	min of: 29,2 66,9/k <sub>mod</sub>	min of: 37,7 66,9/k <sub>mod</sub>	min of: 44 66,9/k <sub>mod</sub>	min of: 42,7 66,9/k <sub>mod</sub>	min of: 54,2 66,9/k <sub>mod</sub>	min of: 66,2 66,9/k <sub>mod</sub>
Nailing pattern 2	30	2 x M12 Bolts	min of: 19,5 66,9/k <sub>mod</sub>	min of: 22,3 66,9/k <sub>mod</sub>	min of: 28,3 66,9/k <sub>mod</sub>	min of: 32,5 66,9/k <sub>mod</sub>	min of: 28,9 66,9/k <sub>mod</sub>	min of: 36,5 66,9/k <sub>mod</sub>	min of: 40,8 66,9/k <sub>mod</sub>
Nailing pattern 3	17	2 x M12 Bolts	min of: 6 66,9/k <sub>mod</sub>	min of: 7,1 66,9/k <sub>mod</sub>	min of: 9,3 66,9/k <sub>mod</sub>	min of: 11,2 66,9/k <sub>mod</sub>	min of: 12,3 66,9/k <sub>mod</sub>	min of: 15,7 66,9/k <sub>mod</sub>	min of: 18,9 66,9/k <sub>mod</sub>

) b=0 & e=0

Table D58-4.2 - Optimized for Nails

1 Angle Bracket ABR255 per connection			Characteristic capacity (kN) per connection						
			R <sub>2/3,k</sub> Optimized for Nails **)						
Nailing pattern	Number of fasteners		CNA Connector Nails				CSA Connector Screws		
	Flange A	Flange B	4,0x35	4,0x40	4,0x50	4,0x60	5,0x35	5,0x40	5,0x50
Nailing pattern 1	52	2 x M12 Bolts	min of: 47,1 61,3/k <sub>mod</sub>	min of: 52,3 61,3/k <sub>mod</sub>	min of: 64,8 61,3/k <sub>mod</sub>	min of: 70,3 61,3/k <sub>mod</sub>	min of: 56,5 61,3/k <sub>mod</sub>	min of: 71,1 61,3/k <sub>mod</sub>	min of: 77,7 61,3/k <sub>mod</sub>
Nailing pattern 2	30	2 x M12 Bolts	min of: 30,9 61,3/k <sub>mod</sub>	min of: 33,9 61,3/k <sub>mod</sub>	min of: 41,8 61,3/k <sub>mod</sub>	min of: 45,7 61,3/k <sub>mod</sub>	min of: 36,2 61,3/k <sub>mod</sub>	min of: 45,5 61,3/k <sub>mod</sub>	min of: 49,6 61,3/k <sub>mod</sub>
Nailing pattern 3	17	2 x M12 Bolts	min of: 18,5 57,6/k <sub>mod</sub>	min of: 20,2 57,6/k <sub>mod</sub>	min of: 24,8 57,6/k <sub>mod</sub>	min of: 26,4 57,6/k <sub>mod</sub>	min of: 20,6 57,6/k <sub>mod</sub>	min of: 25,8 57,6/k <sub>mod</sub>	min of: 8 57,6/k <sub>mod</sub>

\*\*) Different lever arms for:

Nailing pattern 1: b = 28 mm ; e = 15 mm - Intermediate values of b and e can be found by linear interpolation

Nailing pattern 2: b = 28 mm ; e = 15 mm - Intermediate values of b and e can be found by linear interpolation

Nailing pattern 3: b = 38 mm ; e = 20 mm - Lever arms are fixed

The bolts have to be checked for:  $V_{y,d} = F_{2/3,d}$   $M_{x,d} = F_{2/3,d} \times e$   $M_{y,d} = F_{2/3,d} \times b$

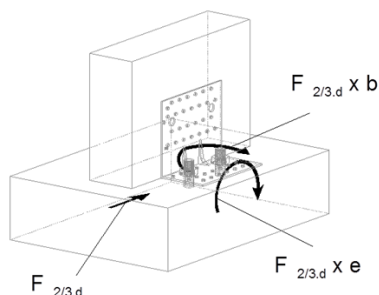

Table D58-5: *ABR255 Slip modulus  $K_{ser}$  – timber to rigid*

1 Angle Bracket ABR255 per connection			Slip modulus $k_{ser}$ (kN/mm)													
			For force $F_1$							For force $F_2$						
Nailing pattern	Number of fasteners		CNA Connector Nails				CSA Connector Screws			CNA Connector Nails				CSA Connector Screws		
	Flange A	Flange B	4,0x35	4,0x40	4,0x50	4,0x60	5,0x35	5,0x40	5,0x50	4,0x35	4,0x40	4,0x50	4,0x60	5,0x35	5,0x40	5,0x50
Nailing pattern 1	52	2 x M12 Bolts	6,1	7,2	9,4	11,3	12,0	15,4	18,3	8,5	9,5	11,7	12,7	10,2	12,9	14,1
Nailing pattern 2	30	2 x M12 Bolts	2,6	3,1	4,1	5,0	5,8	7,5	9,3	5,6	6,1	7,6	8,3	6,6	8,2	9,0
Nailing pattern 3	17	2 x M12 Bolts	2,5	3,0	3,8	4,5	4,4	5,6	6,4	3,3	3,7	4,5	4,8	3,7	4,7	5,1

Table D58-6: *ABR255 Slip modulus  $K_{ser}$  – timber to timber*

1 Angle Bracket ABR255 per connection			Slip modulus $k_{ser}$ (kN/mm)													
			For force $F_1$							For force $F_2$						
Nailing pattern	Number of fasteners		CNA Connector Nails				CSA Connector Screws			CNA Connector Nails				CSA Connector Screws		
	Flange A	Flange B	4,0x35	4,0x40	4,0x50	4,0x60	5,0x35	5,0x40	5,0x50	4,0x35	4,0x40	4,0x50	4,0x60	5,0x35	5,0x40	5,0x50
Nailing pattern 1	52	41	6,9	7,9	9,6	11,1	13,8	17,0	-	4,6	5,1	6,3	6,9	5,7	7,2	8,0
Nailing pattern 2	30	23	6,0	6,7	8,1	9,6	11,7	13,8	-	3,8	4,2	5,2	5,8	4,8	6,0	6,6
Nailing pattern 3	17	17	5,0	5,5	6,4	7,4	9,0	11,0	13,4	2,1	2,3	2,9	3,1	2,5	3,1	3,6

## Annex D59 – ABD45100 & ABDW45100

### Product Name:

Product Name	Material reference acc. to clause II-1	Alternative product names
ABD45100	Steel ref. 1	-
ABDW45100	Steel ref. 1	-
ABD45100S	Steel ref. 2	-
ABDW45100S	Steel ref. 2	-
ABD45100S2	Steel ref. 3	-
ABDW45100S2	Steel ref. 3	-

### Connector Size Range:

Model no.	Dimensions [mm]				Holes flange A	Holes flange B	
	A	B	C	Thickness	Ø5	Ø5	Ø13x21
ABD45100 ABDW45100	100	45	55	3,0	10	4	1
Washer	-	40	50	10	0	0	1

### Drawing:

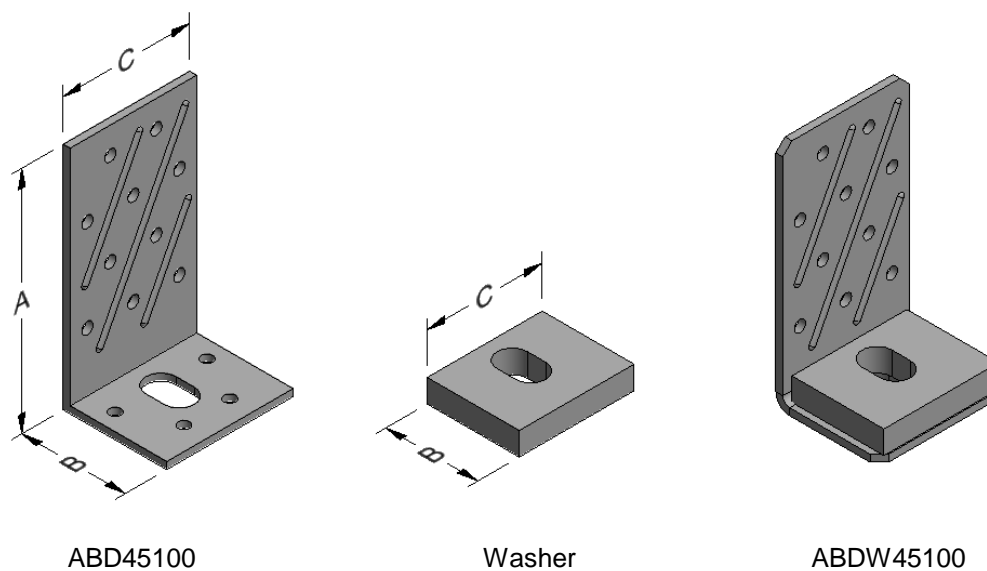

**Nailing pattern:**

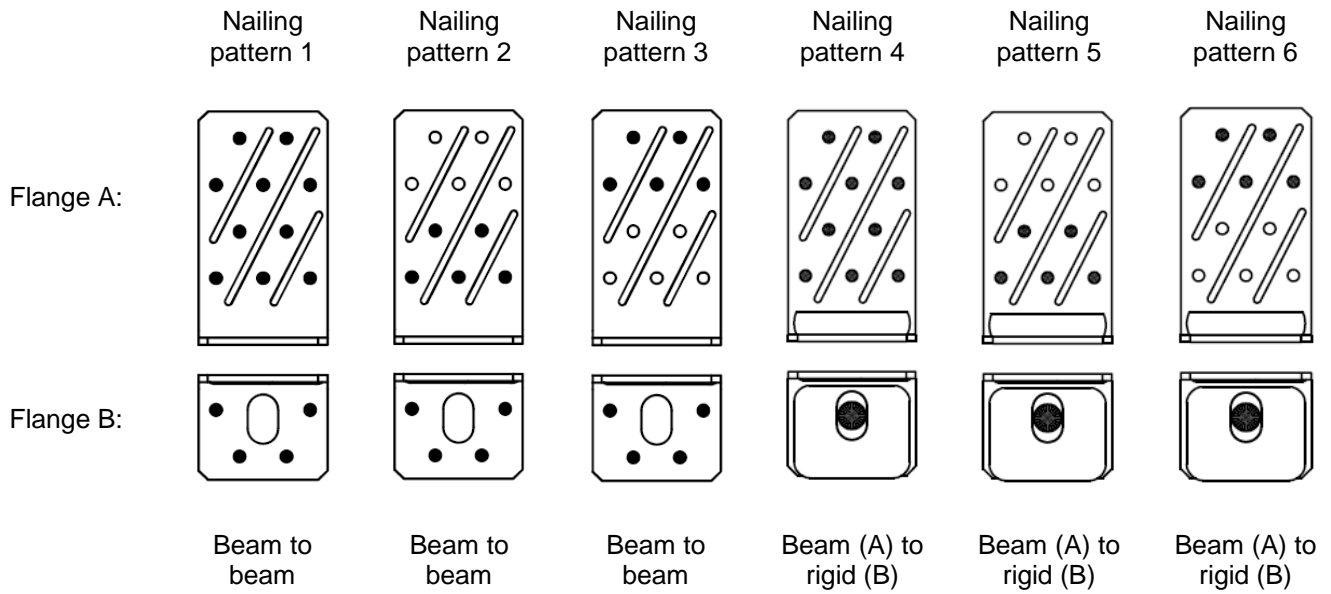

*Table D59-1: Characteristic capacity 1 Angle Bracket*

1 Angle Bracket ABD45100/ABDW45100 per connection			Characteristic capacities $R_{1,k}$ [kN] per connection			
Nailing pattern	Number of fasteners		CNA connector nails			
	Flange A	Flange B	4,0x35	4,0x40	4,0x50	4,0x60
Nailing pattern 1	10	4	Min of:	Min of:		
Nailing pattern 2	5	4	1,47	1,96	$21,2 / ((f+15) \times k_{mod})$	$21,2 / ((f+15) \times k_{mod})$
Nailing pattern 3	5	4	$21,2 / ((f+15) \times k_{mod})$	$21,2 / ((f+15) \times k_{mod})$		
Nailing pattern 4	10	1 Bolt	$36,5 / ((f + 6) \times k_{mod})$			
Nailing pattern 5	5	1 Bolt				
Nailing pattern 6	5	1 Bolt				

The necessary capacity of bolt has to be as minimum:

$$R_{bolt.axial} = F_{1,d} \times (40 \text{ mm} + f) / 23 \text{ mm}$$

f in [mm]



*Table D59-2: Characteristic capacity 2 Angle Brackets*

2 Angle Brackets ABD45100/ABDW45100 per connection			Characteristic capacities [kN] per connection				Characteristic capacities [kN] per connection			
			$R_{1,k}$				$R_{2/3,k}$			
Nailing pattern	Number of fasteners		CNA connector nails				CNA connector nails			
	Flange A	Flange B	4,0x35	4,0x40	4,0x50	4,0x60	4,0x35	4,0x40	4,0x50	4,0x60
Nailing pattern 1	10	4	2,94	3,92	4,9	5,81	6,07	7,01	8,86	10,18
Nailing pattern 2	5	4	2,94	3,92	4,9	5,81	5,65	6,22	7,47	8,12
Nailing pattern 3	5	4	2,94	3,92	4,9	5,81	3,49	3,82	4,57	4,94
Nailing pattern 4	10	1 Bolt	16,2/ $k_{mod}$	16,2/ $k_{mod}$	16,2/ $k_{mod}$	16,2/ $k_{mod}$	4,82	6,26	7,51	8,58
Nailing pattern 5	5	1 Bolt	15,4/ $k_{mod}$	16,2/ $k_{mod}$	16,2/ $k_{mod}$	16,2/ $k_{mod}$	4,1	5,2	6,05	6,73
Nailing pattern 6	5	1 Bolt	16,2/ $k_{mod}$	16,2/ $k_{mod}$	16,2/ $k_{mod}$	16,2/ $k_{mod}$	1,3	1,7	2,05	2,36

The necessary capacity of bolt has to be as minimum:

$$R_{\text{bolt.axial}} = F_{1,d} \times 1.65$$

$$R_{\text{bolt.axial}} = F_{2,d} \times 0.4 \quad R_{\text{bolt.lat}} = F_2$$

With:

$$R_{\text{bolt.axial}} = \text{axial capacity of the bolt / both bolts (connection with 1 / 2 ABD)}$$

$$R_{\text{bolt.lat}} = \text{lateral capacity of the bolt / both bolts (connection with 1 / 2 ABD)}$$

For connection with one ABD, the half of capacities as for connection with 2 ABD can be used, if the timber elements are prevented against rotation.

## Annex D60 – ADR6090L

### Product Name:

Product Name	Material reference acc. to clause II-1	Alternative product names
ADR6090L	Steel ref. 1	-
ADR6090LS	Steel ref. 2	-
ADR6090LS2	Steel ref. 3	-

### Connector Size Range:

Model no.	Dimensions [mm]				Holes flange A			Holes flange B		
	A	B	C	Thickness	Ø5	Oblong 12x40	Oblong 5x30	Ø5	Oblong 12x20	Oblong 10,5x20
ADR6090L	89,5	59,5	60	2,0	5	1	1	4	1	1

### Drawings:

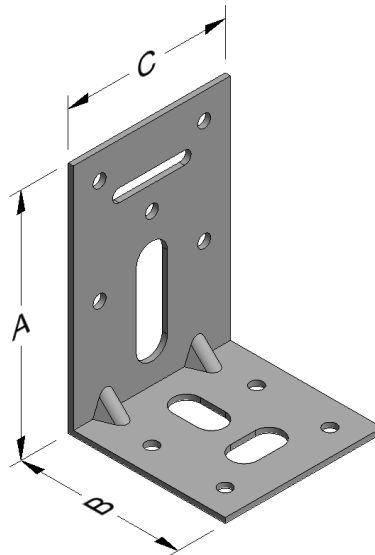

### Nailing pattern:

Nailing pattern 1

Nailing pattern 2

Flange A:

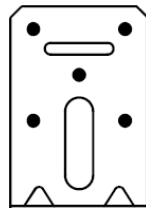
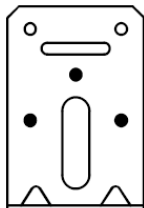

Flange B:

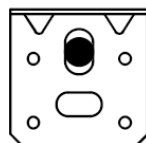
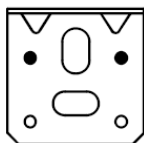

Beam to beam

Beam (A) to rigid (B)

**Characteristic Capacities:**

The values  $R_{i,k}$  for one ADR6090L per connection are stated in the tables below.

For a connection with 2 x ADR6090L the values ("rotation is prevented") can be doubled.

*Table D60-1 Timber to timber - F1 - 1 Angle Bracket*

1 x ADR6090L per Connection	Characteristic capacity $R_{1,k}$ per connection [kN]	
	Purlin is free to rotate	Purlin is prevented to rotate
Nailing pattern 1 Flange A: 3 Flange B: 2		
Fastener		
CNA4,0x35	min. $[(11/k_{mod})/(f+20) ; 37/(f+50)]$	$1,1 / k_{mod}^{0,3}$
CNA4,0x40	$(11/k_{mod}) / (f+20)$	$1,3 / k_{mod}^{0,3}$
CNA4,0x50	$(11/k_{mod}) / (f+20)$	min. $[1,55/k_{mod}^{0,3} ; 1,5/k_{mod}]$
CNA4,0x60	$(11/k_{mod}) / (f+20)$	min. $[1,8/k_{mod}^{0,3} ; 1,5/k_{mod}]$
CSA5,0x35	$(11/k_{mod}) / (f+20)$	$1,5 / k_{mod}$
CSA5,0x40	$(11/k_{mod}) / (f+20)$	$1,5 / k_{mod}$
CSA5,0x50	$(11/k_{mod}) / (f+20)$	$1,5 / k_{mod}$

*Table D60-2 Timber to timber – F2/3-horizontal force - 2 Angle Brackets*

2 x ADR6090L per Connection	Characteristic capacity $R_{2/3,k}$ per connection [kN]
Nailing pattern 1 Flange A: 3 Flange B: 2	
Fastener	
CNA4,0x35	2,7
CNA4,0x40	3,0
CNA4,0x50	3,8
CNA4,0x60	4,2
CSA5,0x35	4,7
CSA5,0x40	5,5
CSA5,0x50	6,6

*Table D60-3 Timber to rigid support - F1*

Nailing pattern 2 Flange A: 5 Flange B: 1 Bolt	Characteristic capacity $R_{1,k}$ per connection [kN]	
	1 x ADR6090L	2 x ADR6090L
Fastener		
CNA4,0x35	min. [13,6 ; 9,9/ $k_{mod}$ ]	$(28/k_{mod}) / (f+30)$
CNA4,0x40	min. [9,3 ; 9,9/ $k_{mod}$ ]	$(35/k_{mod}) / (f+30)$
CNA4,0x50	9,9 / $k_{mod}$	
CAN 4,0x60		
CSA5,0x35		
CSA5,0x40		
CSA5,0x50		

Check of Bolts has to be done separately.

*Table D60-4 Timber to rigid support – F2/3 - 2 Angle Brackets*

2 x ADR6090L per Connection	Characteristic capacity $R_{2/3,k}$ per connection [kN]
Nailing pattern 2 Flange A: 5 Flange B: 1 Bolt	
Fastener	
CNA4,0x35	3,6
CNA4,0x40	4,1
CNA4,0x50	5,2
CAN 4,0x60	5,9
CSA5,0x35	5,8
CSA5,0x40	6,6
CSA5,0x50	7,8

Check of Bolts has to be done separately.

Bolt factors:

Bolt factor	1 x ADR6090L per connection		2 x ADR6090L per connection	
	$R_{1,k}$	$R_{2/3,k}$	$R_{1,k}$	$R_{2/3,k}$
$k_{ax}$	$(f+29,5)/10$	-	1,13	-
$k_{lat}$	-	1	-	0,5

For each Bolt it's needed to check:  $R_{bolt,ax,d} \geq k_{ax} \times F_{i,d}$  &  $k_{lat} \times F_{i,d}$

## Annex D61 – ABTR120/180/240

### Product Name:

Product Name	Material reference acc. to clause II-1	Alternative product names
ABTR120	Steel ref. 1	GUTEX Durio® Winkel Typ 120
ABTR180	Steel ref. 1	GUTEX Durio® Winkel Typ 180
ABTR240	Steel ref. 1	GUTEX Durio® Winkel Typ 240
ABTR120S	Steel ref. 2	GUTEX Durio® Winkel Typ 120
ABTR180S	Steel ref. 2	GUTEX Durio® Winkel Typ 180
ABTR240S	Steel ref. 2	GUTEX Durio® Winkel Typ 240
ABTR120S2	Steel ref. 3	GUTEX Durio® Winkel Typ 120
ABTR180S2	Steel ref. 3	GUTEX Durio® Winkel Typ 180
ABTR240S2	Steel ref. 3	GUTEX Durio® Winkel Typ 240

### Connector Size Range:

Model no.	Dimensions [mm]			
	A	B	E	Thickness
ABTR120	350	83	69	2,0 & 3,0
ABTR180	350	116	102	2,0 & 3,0
ABTR240	350	164	150	2,0 & 3,0

### Drawings:

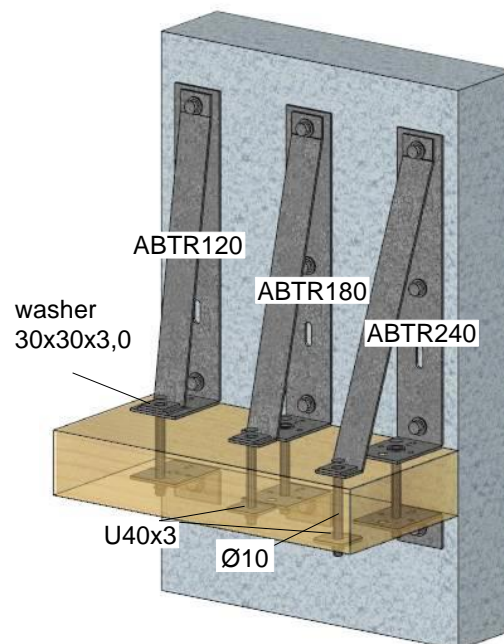
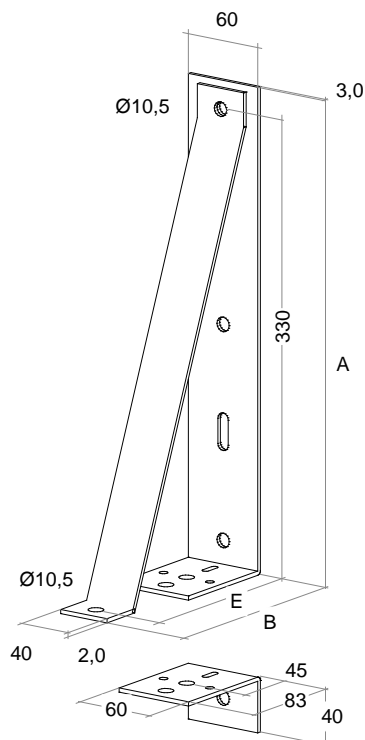

**Assignment:**

Type	Single Components
ABTR120	AB35, TR12, AB4
ABTR180	AB35, TR18, AB4
ABTR240	AB35, TR24, AB4
U40x3	
Washer 30x30x3,0 (DIN436)	

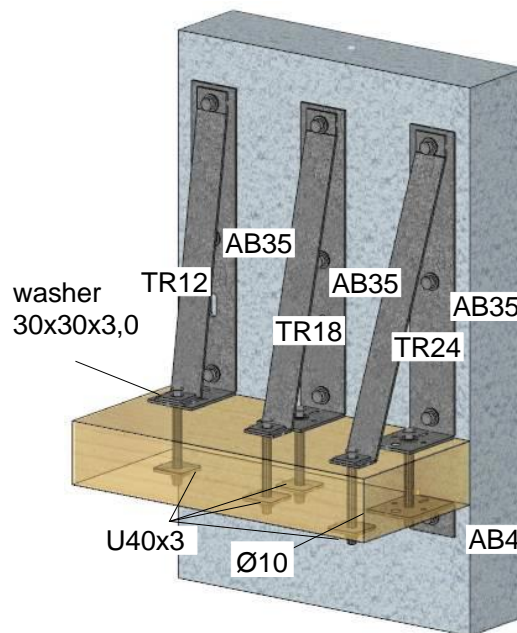

**Characteristic capacity:**

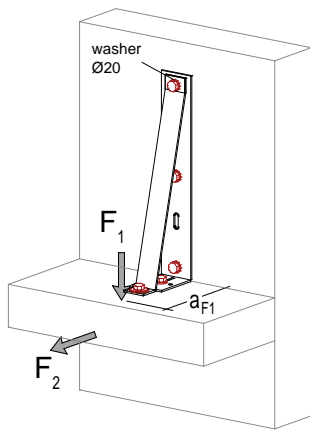

Load directions

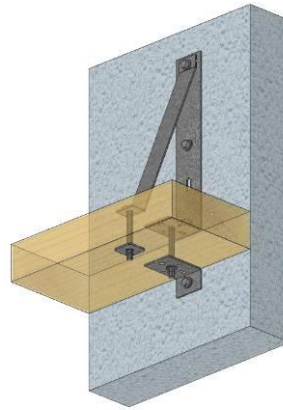

Additional Angle Bracket at the lower side

Table 61-1 Characteristic capacities force direction F1

Washer on the lower side	Type 120 a <sub>dia</sub> = 54mm R <sub>1a.k</sub> [kN]	Type 180 a <sub>dia</sub> = 90mm R <sub>1a.k</sub> [kN]	Type 240 a <sub>dia</sub> = 135mm R <sub>1a.k</sub> [kN]
U40x3	min(14,6 ; 10,17/k <sub>mod</sub> )	min(14,6 ; 10,64/k <sub>mod</sub> )	min(14,6 ; 10,71/k <sub>mod</sub> )
30x30x3	min(9,8 ; 10,17/ k <sub>mod</sub> )	min(9,8 ; 10,64/k <sub>mod</sub> )	min(9,8 ; 10,71/k <sub>mod</sub> )

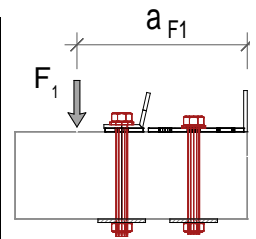

$$R_{1,k} = R_{1a,k} \times a_{dia} / a_{F1}$$

If a<sub>F1</sub> is smaller than a<sub>dia</sub> + 8mm , the calculation has to be done with a<sub>F1</sub> = a<sub>dia</sub> + 8mm.

The required capacities of the anchoring connected to the wall shall be at least:

$$R_{h1,d} = a_{F1} / 330mm \times F_{1,d}$$

$$R_{v1,d} = 1/n \times F_{1,d}$$

$$R_{v2,d} = 1/n \times F_{1,d}$$

$$R_{v3,d} = 1/n \times F_{1,d}$$

$$R_{h3,d} = -a_{F1} / 330mm \times F_{1,d}$$

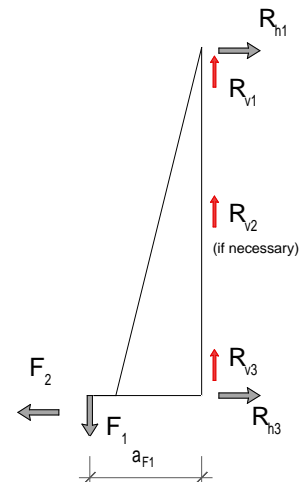

n = number of anchorings (3 for using of all three bolts or 2 for bolts at bottom and top)

Table 61-2 Characteristic capacities force direction F2 (without the AB4)

R <sub>2,k</sub> [kN]			
type 120	type 180	type 240	AB4
2,34/k <sub>mod</sub>	2,34/k <sub>mod</sub>	2,34/k <sub>mod</sub>	2,34/k <sub>mod</sub>

The AB4 shall be use only additionally with the types 120 to 240.

The required capacity of the lower bolt shall be at least:  $R_{h3,d} = F_{2,d}$

For a connection with the angle bracket AB4 on the lower side of the beam, the force F<sub>2,d</sub> shall equally distributed to both brackets.

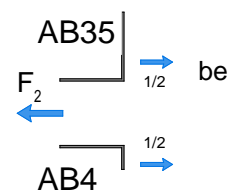

The design capacities have to be calculated as:

$$R_{i,d} = R_{i,k} \times k_{mod} / \gamma_M$$

The brackets are intended to be connected with bolts or screws with a  $\varnothing$  of 10mm. In case timberscrews are used for fixing, also screws with a smaller diameter than  $\varnothing 10$  can be applied with a reducer like the one shown aside. The reducer has to embed into both steel plates.

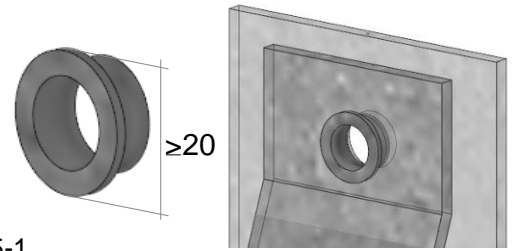

For the distances of the bolts in the beam has to be observe the EN1995-1. The drilling in the beam should be done on site.

**Load combination:**

$F_{1,d} / R_{1,d} \leq 1$  and  $F_{2,d} / R_{2,d} \leq 1$  check of connector

The loads for the anchoring have to be added up, and have to be checked separately according to the individual anchoring type.

**Application:**

The typical installation of the connector may be as follows: An extra layer is added to an existing wall. Columns are placed between the horizontal beams, and on these columns are fixed the outer layer. Insulation is placed between the new outer layer and the existing wall.

Due to the columns, the rotation of the beams is prevented. The vertical load can be calculated with a distance ( $a_{dia} + 8mm$ ) from the wall.

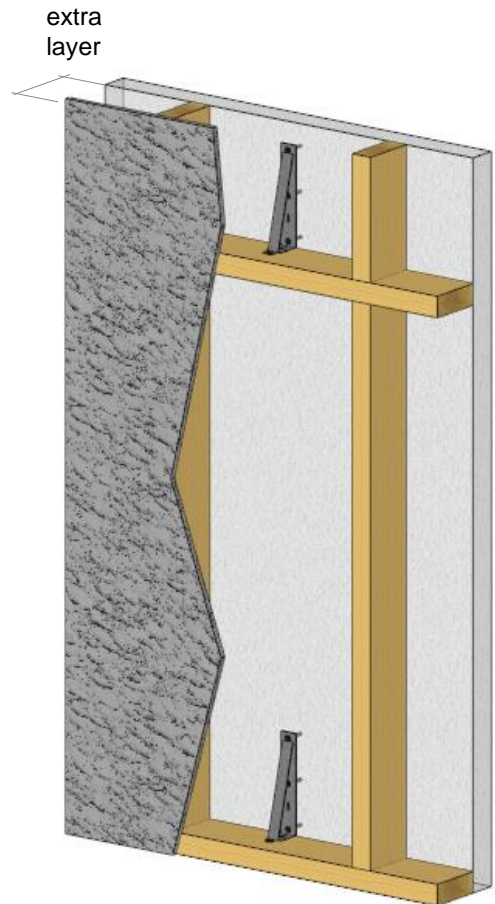

Type	$a_{dia}$ [mm]
ABTR120	54
ABTR180	90
ABTR240	135

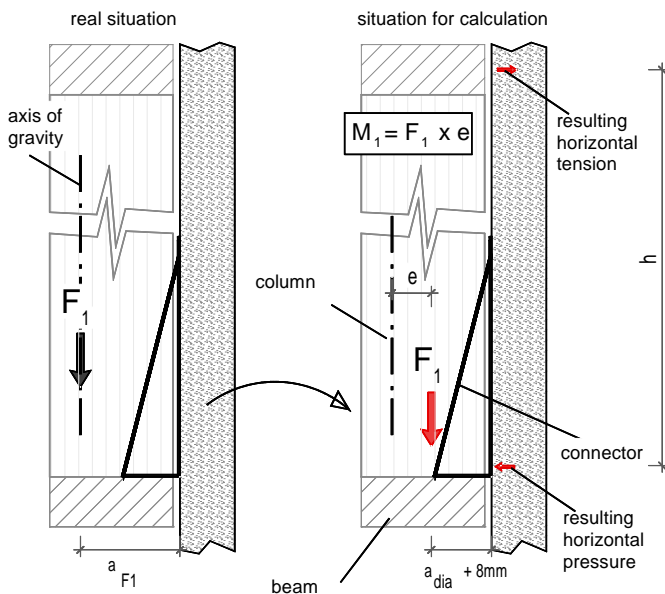

Generally the brackets shall be calculated with a lever arm of  $F_1$  of  $a_{F1} = (a_{dia} + 8mm)$  For beam distances  $h \geq 2000mm$  the resulting centering forces can usually be disregarded. Else all details shall be designed in accordance with EC5.



## Annex D62 – ACW155

### Product Name:

Product Name	Material reference acc. to clause II-1	Alternative product names
ACW155	Steel ref. 1	-
ACW155S	Steel ref. 2	-
ACW155S2	Steel ref. 3	-

### Connector Size Range:

Model no.	Dimensions [mm]				Holes flange A			Holes flange B	
	A	B	C	Thickness	Ø5	Ø9	Oblong 13x30	Ø14	Oblong 13x30
ACW155	154	123	150	2,5	33	2	3	4	2

### Drawings:

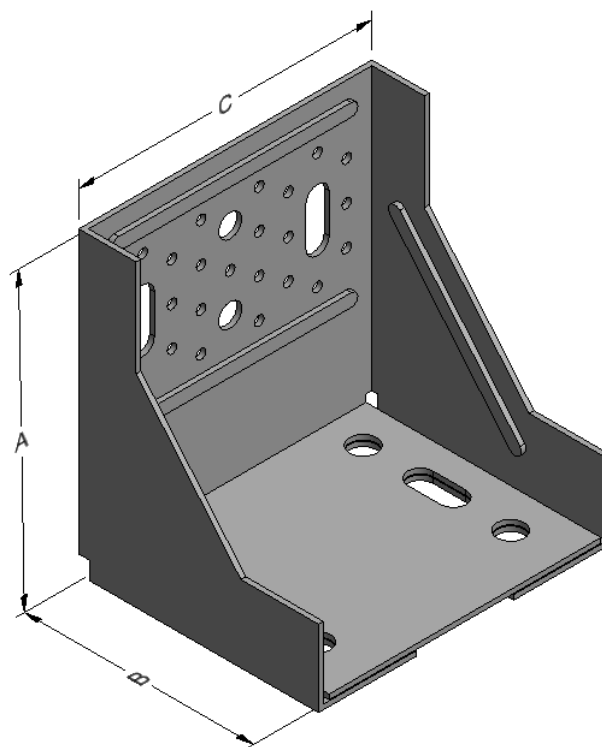

**Nailing pattern:**

nail/ bolt pattern: A

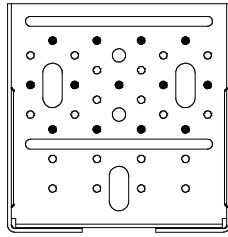

13 x  
CNA4,0x35

nail/ bolt pattern: B

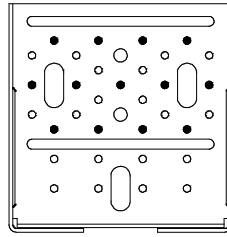

13 x  
CNA4,0x35

nail/ bolt pattern: C

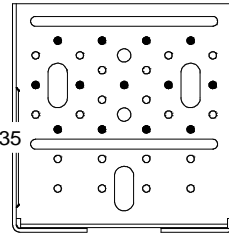

13 x  
CNA4,0x35

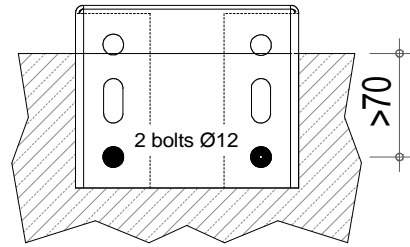
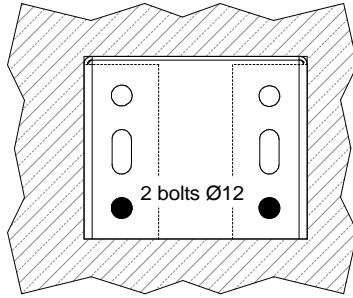
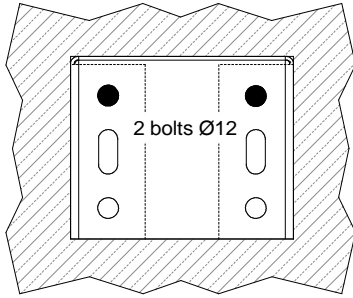

nail/ bolt pattern: D

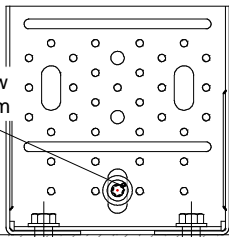

1 screw  
Ø10mm

nail/ bolt pattern: E

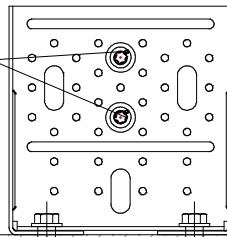

2 screws  
Ø8mm

nail/ bolt pattern: F

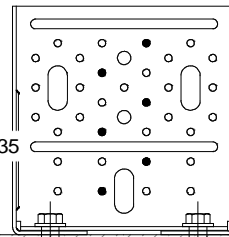

6 x  
CNA4,0x35

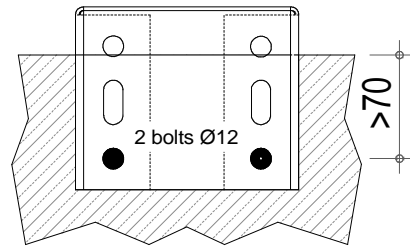
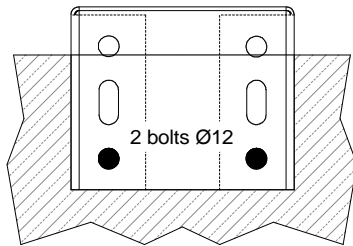
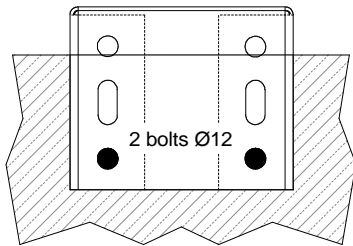

For the nail/bolt pattern A and B, the bolts are positioned with a sufficient distance to any border. The other nail/bolt patterns are for anchorage which has a minimum of 70 mm distance to the border of the concrete.

For nailing patterns B to F, the connected timber elements are free to rotate as the connected elements are fixed at minimum to one other point.

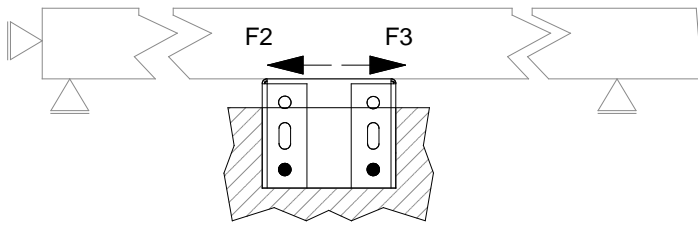

For the nailing patterns D to F, it is determined that a vertical load (F6) is always present.

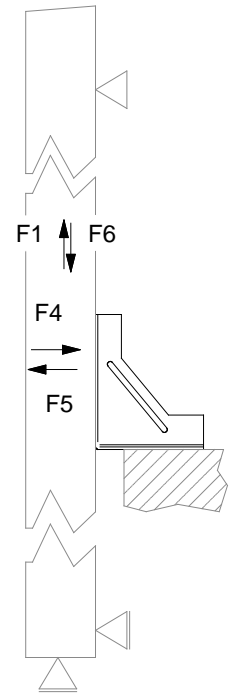

Load directions:

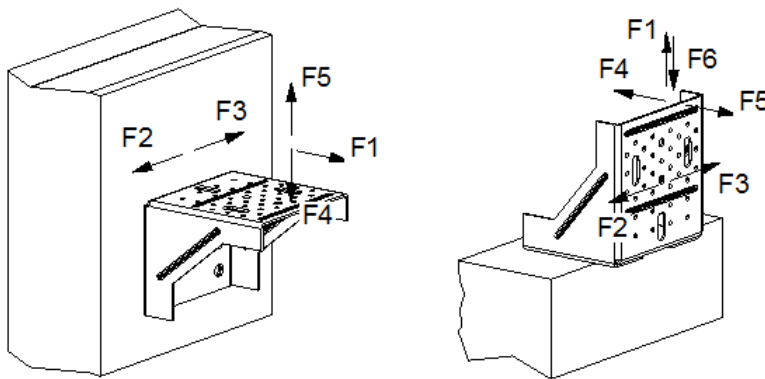

Table 62-1 Characteristic values

Nailing pattern	Number of fasteners		Characteristic capacities [kN]				
	Flange A	Flange B	R <sub>1,k</sub>	R <sub>2/3,k</sub>	R <sub>4,k</sub>	R <sub>5,k</sub>	R <sub>6,k</sub>
A	13 CNA4,0x35	2 x M12 Bolts	16,3	15,3	21,1	5	-
B	13 CNA4,0x35	2 x M12 Bolts	8,8	11,9	6	11,4	21,2
C	13 CNA4,0x35	2 x M12 Bolts	8,8	8,9	6	11,4	21,2
D	1 ESCR Ø10x140	2 x M12 Bolts	-	-	7,5	5,7	-
E	2 ESCR Ø8x100	2 x M12 Bolts	-	-	7,5	3,92	7,73
F	6 CNA4,0x35	2 x M12 Bolts	-	-	7,5	2,64	10,1

The fasteners in the joist/beam can be replaced with different fasteners but must as a minimum have the same capacities of the specified fasteners. For the nail pattern A to C to connect the ACW155, other screws can be used but are also required to have a minimum capacity as the same as the specified fasteners.

The connections with the nail pattern D to F can be used also for the connection of a column.

Load combination:  $\sum (F_{i,d} / R_{i,d}) \leq 1,0$

The anchorage must be checked with the following loads:

*Table 62-2 Bolt factors*

Nailing pattern	The anchorage has to be checked for following:							
	for F <sub>1</sub>	for F <sub>2</sub>			for F <sub>4</sub>	for F <sub>5</sub>		for F <sub>6</sub>
	N <sub>Sd</sub>	V <sub>ySd</sub>	M <sub>xSd</sub>	M <sub>zSd</sub>	V <sub>xSd</sub>	V <sub>xSd</sub>	N <sub>Sd</sub>	N <sub>Sd</sub>
A	F <sub>1,d</sub> × 1.1	F <sub>2,d</sub>	F <sub>2,d</sub> × 27mm	F <sub>2,d</sub> × 69mm	F <sub>4,d</sub>	F <sub>5,d</sub>	F <sub>5,d</sub> × 3	-
B	F <sub>1,d</sub> × 3,7	F <sub>2,d</sub>	F <sub>2,d</sub> × 92mm	F <sub>2,d</sub> × 59mm	F <sub>4,d</sub>	F <sub>5,d</sub>	F <sub>5,d</sub> × 1,3	F <sub>6,d</sub> × 0.7
C	F <sub>1,d</sub> × 3,7	F <sub>2,d</sub>	F <sub>2,d</sub> × 82mm	F <sub>2,d</sub> × 59mm	F <sub>4,d</sub>	F <sub>5,d</sub>	F <sub>5,d</sub> × 1,3	F <sub>6,d</sub> × 0.7
D	-	-	-	-	F <sub>4,d</sub>	F <sub>5,d</sub>	F <sub>5,d</sub> × 0.7	-
E	-	-	-	-	F <sub>4,d</sub>	F <sub>5,d</sub>	F <sub>5,d</sub> × 0.9	F <sub>6,d</sub> × 0.7
F	-	-	-	-	F <sub>4,d</sub>	F <sub>5,d</sub>	F <sub>5,d</sub> × 1.3	F <sub>6,d</sub> × 0.7

For load combination, the combination for the anchorage must also be checked.

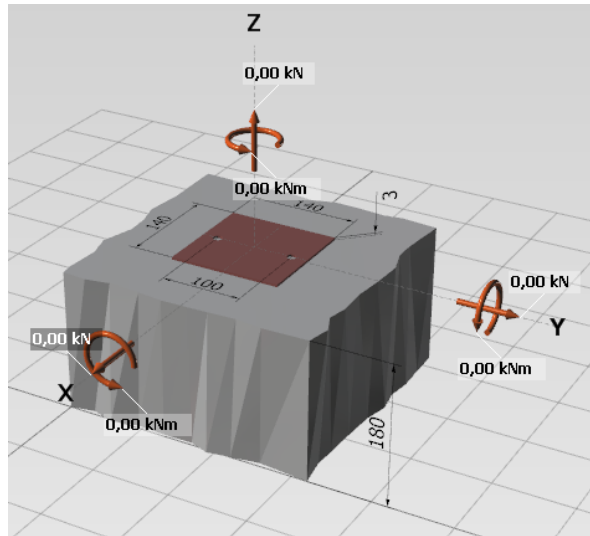
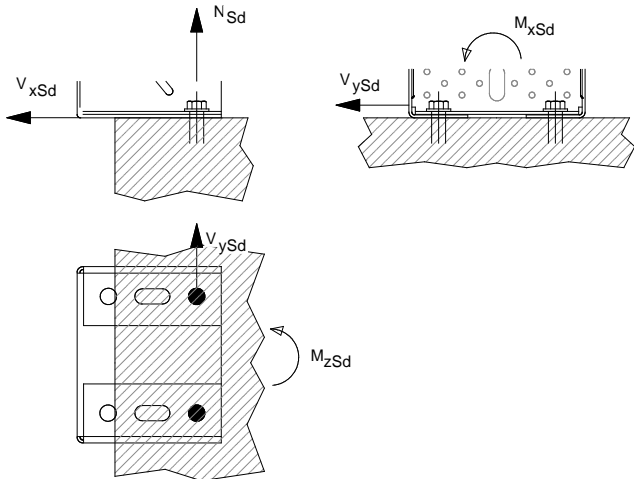

## Annex D63 – AE90-RW

### Product Name:

Product Name	Material reference acc. to clause II-1	Alternative product names
AE-90RW	Steel ref. 1	-
AE-90RWS	Steel ref. 2	-
AE-90RWS2	Steel ref. 3	-

### Connector Size Range:

Model no.	Dimensions [mm]				Holes flange A	Holes flange B	
	A	B	C	Thickness	Ø5	Ø5	Ø14
AE90-RW	90	48	90	2,5	6	7	1

### Drawing:

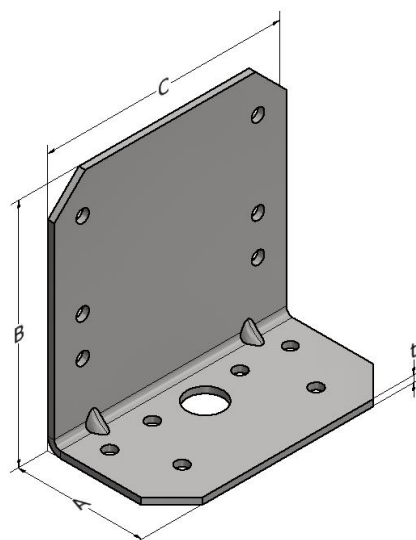

### Nailing pattern:

Nailing pattern 1

Flange A:

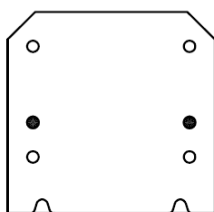

Flange B:

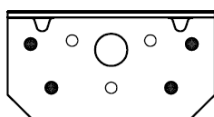

Rockwool Post (A) to  
beam (B)

*Table D63-1 Characteristic capacity - Composite Metal beam to timber beam – 2 Angle Brackets*

2 Angle brackets AE90-RW per connection			Characteristic capacity per connection (kN)
Nailing pattern	Number of fasteners		$R_{1,k}$
	Flange A	Flange B	
Nailing pattern 1	2 Self drilling screws Ø5.5x50	8 CSA5.0x40	9.8 / $k_{mod}$

