



Austrian Institute of Construction Engineering
 Schenkenstrasse 4 | T+43 1 533 65 50
 1010 Vienna | Austria | F+43 1 533 64 23
 www.oib.or.at | mail@oib.or.at



European Technical Assessment

ETA-11/0454
 of 28.02.2017

General part

Technical Assessment Body issuing the European Technical Assessment

Österreichisches Institut für Bautechnik (OIB)
 Austrian Institute of Construction Engineering

Trade name of the construction product

System Armaflex Protect

Product family to which the construction product belongs

Fire Stopping and Fire Sealing Products:
 Penetration Seals

Manufacturer

Armacell GmbH
 Robert-Bosch-Straße 10
 48153 Münster
 GERMANY

Manufacturing plant

Armacell plant 1 and plant 4

This European Technical Assessment contains

23 pages including Annexes A-1 to B-8 which form an integral part of this assessment

This European Technical Assessment is issued in accordance with Regulation (EU) No 305/2011, on the basis of

Guideline for European technical approval for "Fire Stopping and Fire Sealing Products", ETAG 026 Part 2: "Penetration Seals", edition August 2011, used as European Assessment Document (EAD)

This European Technical Assessment replaces

European technical approval ETA-11/0454 with validity from 21.12.2011 to 20.12.2016

This European Technical Assessment is not to be transferred to manufacturers or agents of manufacturer other than those indicated on page 1, or manufacturing plants other than those laid down in the context of this European Technical Assessment.

Translations of this European Technical Assessment in other languages shall fully correspond to the original issued document and should be identified as such.

Communication of this European Technical Assessment, including transmission by electronic means, shall be in full. However, partial reproduction can be made with the written consent of the Österreichisches Institut für Bautechnik. In this case, partial reproduction has to be designated as such.

This European Technical Assessment may be withdrawn by the Österreichisches Institut für Bautechnik, in particular pursuant to information by the Commission according to Article 25 (3) of Regulation (EU) No 305/2011.

electronic copy
electronic copy
electronic copy
electronic copy
electronic copy
electronic copy
electronic copy

Specific parts

1 Technical description of the product

“System Armaflex Protect” is a kit to be used as pipe penetration seal based on the following components and additional gap fillers.

Components of “System Armaflex Protect”	Characteristics
Armaflex Protect	Closed cell elastomeric foam insulation with intumescent fire protection additives in form of tubes and sheets
AF/Armaflex	Closed cell, flexible elastomeric foam (FEF) insulation in form of (slotted) tubes and sheets (can be provided with a self-adhesive device)
Armaflex Band selbstklebend (Armaflex self-adhesive tape)	Closed cell, flexible elastomeric foam (FEF) insulation in form of tapes with a self-adhesive device
Armaflex 520	Polychlorene-based adhesive, free from aromatic compounds (special adhesive for processing of all flexible Armaflex insulating material – except HT/Armaflex and Armacell products based on Armaprene)
Additional components – Gap fillers	Characteristics
Gap filler	Non-combustible material with classification A1 or A2-s1,d0 according to EN 13501-1 which is dimensionally stable as e.g. mortar, cement or gypsum joint filler

2 Specification of the intended use(s) in accordance with the applicable European Assessment Document

2.1 Intended use

“System Armaflex Protect” is intended to be used as a pipe penetration seal to temporarily or permanently reinstate the fire resistance performance of flexible wall constructions, rigid wall constructions and rigid floor constructions where they have been provided with apertures which are penetrated by various multi-layer composite pipes, metal pipes, auxiliary cables and auxiliary heaters.

“System Armaflex Protect” can be installed only in the types of separating elements as specified in the following table.

Separating element	Construction
Flexible walls	<ul style="list-style-type: none">> Steel studs or timber studs lined on both faces with minimum 2 layer of boards (minimum thickness 12,5 mm) with classification A2-s1,d0 or A1 according to EN 13501-1> For timber stud walls there shall be a minimum distance of 100 mm of the penetration seal to any timber stud. The cavity between the penetration seal and the timber stud has to be closed with minimum 100 mm of insulation with classification A1 or A2 according to EN 13501-1> Minimum thickness 94 mm> Classification according to EN 13501-2: $\geq EI 90$> This European Technical Assessment does not cover sandwich panel constructions and flexible walls were the lining does not cover studs on both sides. Penetrations in such constructions shall be tested on a case by case basis
Rigid walls	<ul style="list-style-type: none">> Aerated concrete, concrete, masonry> Minimum thickness 100 mm> The rigid wall shall be classified in accordance with EN 13501-2 for the required fire resistance period
Rigid floors	<ul style="list-style-type: none">> Aerated concrete, concrete> Minimum density 550 kg/m³> Minimum thickness 150 mm> The rigid floor shall be classified in accordance with EN 13501-2 for the required fire resistance period

2.2 Use category

“System Armaflex Protect” is intended for use at temperatures below 0 °C, but with no exposure to rain nor UV, and can therefore – according to ETAG 026-Part 2 clause 2.4.12.1.3.3 – be categorized as Type Y₂. Since the requirements for Type Y₂ are met, also the requirements for Type Z₁ and Z₂ are fulfilled.

Although a penetration seal is intended for indoor applications only, the construction process may result in it being subjected to more exposed conditions for a period before the building envelope is closed. For this case provisions shall be made to protect temporarily exposed penetration seals according to the ETA-holder’s installation instructions.

2.3 Working life

The provisions made in this European Technical Assessment are based on an assumed working life of “System Armaflex Protect” of 10 years, provided the conditions laid down in the technical literature of the manufacturer relating to packaging, transport, storage, installation, use and repair are met.

The indications given on the intended working life cannot be interpreted as a guarantee given by the producer or the Technical Assessment Body, but are to be regarded only as a means for selecting the appropriate product in relation to the expected economically reasonable working life of the works.

The real working life might be, in normal use conditions, considerably longer without major degradation affecting the Basic requirements for construction works.

2.4 General assumptions

2.4.1 It is assumed that

- > damages to the penetration seal are repaired accordingly,
- > the installation of the penetration seal does not effect the stability of the adjacent building element – even in case of fire,
- > the lintel or floor above the penetration seal is designed structurally and in terms of fire protection such that no additional mechanical load (other than its own weight) is imposed on the penetration seal,
- > the thermal movement in the pipe work will be accommodated in such way that it does not impose a load on the penetration seal,
- > the installations are fixed to the adjacent building element in accordance with the relevant regulations in such a way that, in case of fire, no additional mechanical load is imposed to the penetration seal,
- > the support of the installations is maintained for the required period of fire resistance and
- > pneumatic dispatch systems, compressed air systems, etc. are switched off by additional means in case of fire.

2.4.2 This European Technical Assessment does not address any risks associated with the emission of dangerous liquids or gases caused by failure of the pipe(s) in case of fire nor does it prove the prevention of the transmission of fire through heat transfer via the medium in the pipes.

2.4.3 This European Technical Assessment does not verify the prevention of destruction of adjacent building elements with fire separating function or of the pipes themselves due to distortion forces caused by extreme temperatures. These risks shall be accounted for by taking appropriate measures when designing or installing the pipe work.

The mounting or hanging of the pipes or the layout of the pipe work shall be implemented in such a way that the pipes and the fire resistant building elements shall remain functional within a period of time which corresponds to the fire resistance period required.

2.4.4 The risk of downward spread of fire caused by burning material which drips through a pipe to floors below, is not considered in this European Technical Assessment (see EN 1366-3:2009, clause 1).

2.4.5 The durability assessment does not take account of the possible effect on the penetration seal of substances permeating through the pipe walls.

2.4.6 The assessment does not cover the avoidance of destruction of the penetration seal or of the adjacent building element(s) by forces caused by temperature changes in case of fire. This has to be considered when designing the piping system.

2.5 Manufacturing

The European Technical Assessment is issued for the product on the basis of agreed data/information, deposited with the Österreichisches Institut für Bautechnik, which identifies the product that has been assessed and judged. Changes to the product or production process, which could result in this deposited data/information being incorrect, should be notified to the Österreichisches Institut für Bautechnik before the changes are introduced.

The Österreichisches Institut für Bautechnik will decide whether or not such changes affect the European Technical Assessment and consequently the validity of the CE marking on the basis of the European Technical Assessment and if so whether further assessment or alterations to the European Technical Assessment, shall be necessary.

3 Performance of the product and references to the methods used for its assessment

Basic requirements for construction works	Essential characteristic	Method of verification	Performance
BWR 2	Reaction to fire	EN 13501-1	Clause 3.1.1 of the ETA
	Resistance to fire	EN 13501-2: 2007+A1:2009	Clause 3.1.2 of the ETA and Annex B-1 to B-8 of the ETA

Basic requirements for construction works	Essential characteristic	Method of verification	Performance
BWR 3	Air permeability (material property)	No performance assessed	
	Water permeability (material property)	No performance assessed	
	Content and/or release of dangerous substances	European Council Directive 67/548/EEC and Regulation (EC) No 1272/2008 as well as EOTA TR 034, edition October 2015	Declaration of conformity by the manufacturer
BWR 4	Mechanical resistance and stability	No performance assessed	
	Resistance to impact / movement	No performance assessed	
	Adhesion	No performance assessed	
BWR 5	Airborne sound insulation	No performance assessed	
BWR 6	Thermal properties	No performance assessed	
	Water vapour permeability	No performance assessed	

3.1 Safety in case of fire (BWR 2)

3.1.1 Reaction to fire

The components of “System Armaflex Protect” were assessed according to ETAG 026-Part 2 clause 2.4.1 and classified according to EN 13501-1.

Component	Class according to EN 13501-1
Armaflex Protect including Armaflex Band selbstklebend (Armaflex self-adhesive tape) and Armaflex 520	E (sheet) / E_L (tube) on metal pipes and multi-layer composite pipes
AF/Armaflex and Armaflex 520	B-s3,d0 (sheet) / B_L-s3,d0 (tube) on metal pipes E_L (tube) on multi-layer composite pipes

3.1.2 Resistance to fire

“System Armaflex Protect” was tested according to ETAG 026-Part 2 clause 2.4.2, prEN 1366-3.2:N185:2007-07 and EN 1366-3:2009 in conjunction with EN 1363-1:1999.

Based upon the gained test results and the field of application specified within prEN 1366-3.2:N185:2007-07 and EN 1366-3:2009 the pipe penetration seal “System Armaflex Protect” has been classified according to EN 13501-2:2007+A1:2009.

The fire resistance classes of the penetration seal “System Armaflex Protect” in the relevant separating elements are listed in Annex B-1 to Annex B-8 of the ETA.

The resistance to fire classification listed in Annex B-1 to Annex B-8 is only valid if “System Armaflex Protect” is installed according to Annex A-1 to Annex A-4 of the ETA.

3.2 Hygiene, health and environment (BWR 3)

3.2.1 Air permeability

No performance assessed.

3.2.2 Water permeability

No performance assessed.

3.2.3 Release of dangerous substances

According to the manufacturer’s declaration the components of “System Armaflex Protect” do not contain dangerous substances detailed in Council Directive 67/548/EEC and Regulation (EC) no 1272/2008 as well as EOTA TR 034 (General BWR 3 Checklist for EADs/ETAs – Dangerous substances), edition October 2015 above the acceptable limits.

A written declaration in this respect was submitted by the ETA-holder.

In addition to the specific clauses relating to dangerous substances contained in this European Technical Assessment, there may be other requirements applicable to the products falling within its scope (e.g. transposed European legislation and national laws, regulations and administrative provisions). In order to meet the provisions of the Construction Products Regulation, these requirements need also to be complied with, when and where they apply.

3.3 Safety in use (BWR 4)

3.3.1 Mechanical resistance and stability

No performance assessed.

3.3.2 Resistance to impact / movement

No performance assessed.

3.3.3 Adhesion

No performance assessed.

3.4 Protection against noise (BWR 5)

3.4.1 Airborne sound insulation

No performance assessed.

3.5 Energy economy and heat retention (BWR 6)

3.5.1 Thermal properties
No performance assessed.

3.5.2 Water vapour permeability
No performance assessed.

3.6 General aspects relating to fitness for use

All components of „System Armaflex Protect” were tested according to ETAG 026-Part 2 clause 2.4.12.

All components of “System Armaflex Protect” fulfil the requirements for the intended use category.

“System Armaflex Protect” is therefore appropriate for use at temperatures below 0 °C, but with no exposure to rain nor UV, and can therefore – according to ETAG 026-Part 2 clause 2.4.12.1.3.3 – be categorized as Type Y₂. Since the requirements for Type Y₂ are met, also the requirements for Type Z₁ and Z₂ are fulfilled.

4 Assessment and verification of constancy of performance (hereinafter AVCP) system applied, with reference to its legal base

4.1 AVCP system

According to the Decision 1999/454/EC¹, amended by Decision 2001/596/EC² of the European Commission the system(s) of assessment and verification of constancy of performance (see Annex V of Regulation (EU) No 305/2011) is given in the following table.

Product(s)	Intended use(s)	Level(s) or class(es) (resistance to fire)	System of assessment and verification of constancy of performance
Fire Stopping and Fire Sealing Products	for fire compartmentation and/or fire protection or fire performance	any	1

In addition, according to the Decision 1999/454/EC, amended by Decision 2001/596/EC of the European Commission the system(s) of assessment and verification of constancy of performance, with regard to reaction to fire, is given in the following table.

Product(s)	Intended use(s)	Level(s) or class(es) (reaction to fire)	System of assessment and verification of constancy of performance
Fire Stopping and Fire Sealing Products	For uses subject to regulations on reaction to fire	A1*, A2*, B*, C*	1
		A1**, A2**, B**, C**, D, E	3
		(A1 to E)***, F	4
<p>* Products/materials for which a clearly identifiable stage in the production process results in an improvement of the reaction to fire classification (e.g. an addition of fire retardants or a limiting of organic material)</p> <p>** Products/materials not covered by footnote (*)</p> <p>*** Products/materials that do not require to be tested for reaction to fire (e.g. products/materials of class A1 according to Commission Decision 96/603/EC, as amended)</p>			

¹ Official Journal of the European Communities no. L 178, 14.7.1999, p. 52

² Official Journal of the European Communities no. L 209, 2.8.2001, p. 33

electronic copy

5 Technical details necessary for the implementation of the AVCP system, as provided for the applicable European Assessment Document

Technical details necessary for the implementation of the AVCP system are laid down in the control plan deposited with the Technical Assessment Body Österreichisches Institut für Bautechnik.

The notified product certification body shall visit the factory at least once a year for surveillance of the manufacturer.

Issued in Vienna on 28.02.2017
by Österreichisches Institut für Bautechnik

The original document is signed by:

Rainer Mikulits
Managing Director

electronic copy
electronic copy
electronic copy
electronic copy
electronic copy
electronic copy

1 General

- > "System Armaflex Protect" can be used for multi-layer composite pipes and metal pipes according to clause 2.1 of the ETA in apertures in walls (vertical separating element) and floors (horizontal separating element) according to clause 2.1 of the ETA.
- > In rigid floors "System Armaflex Protect" may be penetrated by one auxiliary cable according to clause 2.1 of the ETA which is installed parallel outside of "System Armaflex Protect".
- > In rigid floors "System Armaflex Protect" may be penetrated by one auxiliary heater according to clause 2.1 of the ETA which is installed parallel to the pipe within "Armaflex Protect" with a thickness ≥ 25 mm and an insulation length ≥ 1000 mm.
- > Each multi-layer composite pipe or metal pipe which is to be sealed off has to be equipped separately with "System Armaflex Protect". For details see Annex B-1 to Annex B-8 of the ETA.

1.1 Pipe end configuration

- > For multi-layer composite pipes classified with pipe end configuration U/C the pipe end configuration can be U/C and C/C.
- > For metal pipes classified with pipe end configuration C/U the pipe end configuration can be C/U and C/C.

1.2 Orientation of the penetrating elements

- > Multi-layer composite pipes, metal pipes and additional installed auxiliary cables and auxiliary heaters have to be installed perpendicular to the surface of the separating element.

1.3 Service support constructions

- > All multi-layer composite pipes, metal pipes and additional installed auxiliary cables and auxiliary heaters have to be supported by service support constructions (e.g. pipe hangers) made of metal with a melting or decomposition point greater or equal than 902 °C for EI 45, 945 °C for EI 60, 1006 °C for EI 90 or 1049 °C for EI 120 (e.g. stainless steel or galvanized steel) according to the ETA-holder's installation instructions.
- > In flexible walls and rigid walls the pipes have to be supported on both sides of the separating element.
- > In rigid floors the pipes have to be supported at least on the top side of the separating element.
- > The first support (service support construction) for multi-layer composite pipes, metal pipes and additional installed auxiliary cables and auxiliary heaters in flexible walls, rigid walls and rigid floors has to be at maximum 650 mm (measured from the surface of the separating element).
- > All multi-layer composite pipes, metal pipes and additional installed auxiliary cables and auxiliary heaters have to be fixed according to the ETA-holder's installation instructions to the service support construction.

System Armaflex Protect
- Details for installation -

ANNEX A-1

electronic copy electronic copy electronic copy electronic copy electronic copy electronic copy electronic copy electronic copy electronic copy electronic copy

2 Details for installation of “System Armaflex Protect” (see Annex B-1 to B-8 of the ETA)

- > “System Armaflex Protect” will be formed by installing “Armaflex Protect” – in form of a tube or a sheet – centered in the opening of the separating element on the relevant pipe to be sealed off according to the ETA-holder’s installation instructions.
- > For pipes with diameter $\leq 88,9$ mm “Armaflex Protect” in form of a tube has to be used. The tube of “Armaflex Protect” can be either pushed onto the pipe or slotted and glued at the longitudinal joint.
- > For pipes with diameter $> 88,9$ mm “Armaflex Protect” in form of a sheet has to be used. The sheet of “Armaflex Protect” has to be wrapped around the pipe, bonded at the longitudinal joint and additionally fixed by a winding wire (steel wire with diameter $\geq 0,5$ mm; minimum 6 windings per meter) in place.
- > When installing “Armaflex Protect” all butt joints and longitudinal joints have to be glued with “Armaflex 520” and covered with “Armaflex Band selbstklebend” (Armaflex self-adhesive tape).
- > When installing “AF/Armaflex” all butt joints and longitudinal (except for “AF/Armaflex” with self-adhesive device) joints have to be glued with “Armaflex 520” and can be covered with “Armaflex Band selbstklebend” (Armaflex self-adhesive tape).
- > The strip of “Armaflex Band selbstklebend” (Armaflex self-adhesive tape) has to be 50 mm x 3 mm (width x thickness).
- > Butt joints between “Armaflex Protect” and “AF/Armaflex” have to be glued with “Armaflex 520” according to the ETA holder’s installation instructions.
- > The amount of “Armaflex 520” shall not be more than 300 g/m².

2.1 Insulation length

- > The tube or sheet of “Armaflex Protect” has to be continuous along the required minimum insulation length (≥ 500 mm for multi-layer composite pipes and metal pipes; ≥ 1000 mm for metal pipes with a diameter > 35 mm; for details see Annex B-1 to Annex B-8 of the ETA).
- > In some cases (see Annex B-1 and Annex B-8 of the ETA) it is required to adhere a continuing insulation of “AF/Armaflex” (tubes or sheets) on both sides of “System Armaflex Protect” according to the ETA-holder’s installation instructions.
- > Branches or elbows also have to be equipped with “Armaflex Protect” or in some cases with “AF/Armaflex” along the required minimum insulation length (for details see Annex B-1 to Annex B-8 of the ETA) on both sides of the separating element.

System Armaflex Protect
- Details for installation -

ANNEX A-2

electronic copy

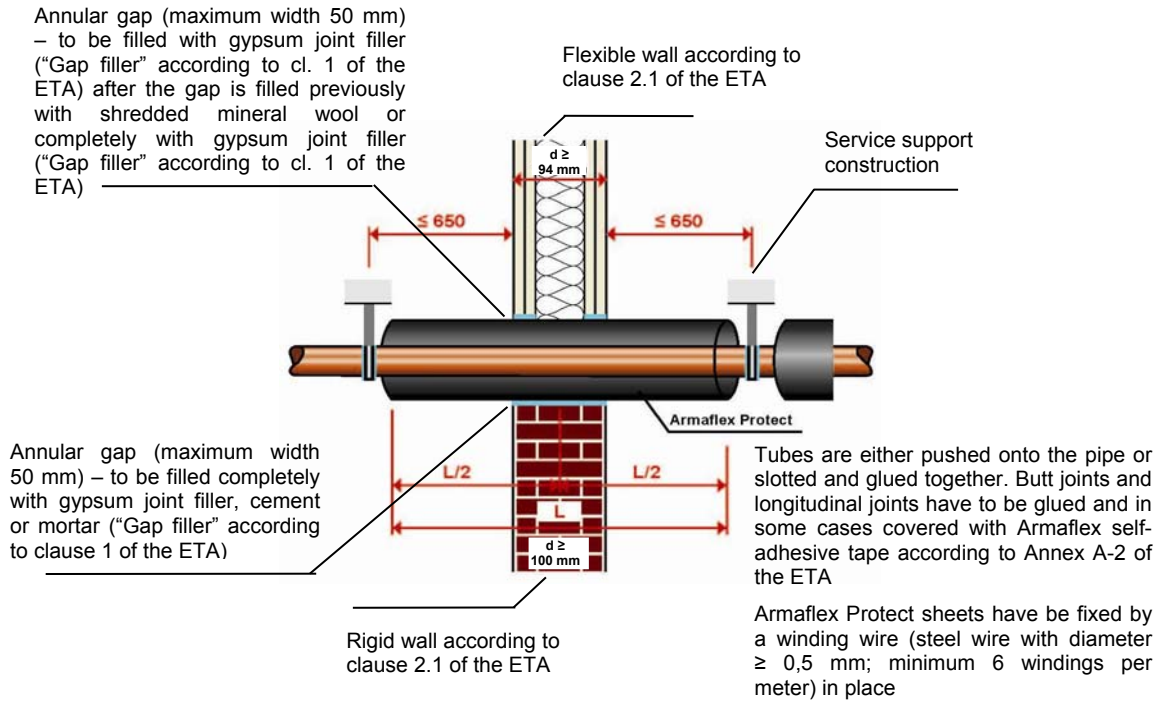

alplex F50 PROFI pipes acc. to cl. 2.1 of the ETA – in flexible walls and rigid walls acc. to cl. 2.1 of the ETA

Pipe dimensions (mm)		Armaflex Protect (local-sustained LS or continued-sustained CS)		AF/Armaflex - continuing insulation		Fire resistance classification
Outer diameter	Wall thickness	Thickness (mm)	Length (mm)	Thickness (mm)	Length (mm)	
16	2,0	20	≥ 500	-	-	EI 120-U/C E 120-U/C
20	2,0	20		-	-	EI 120-U/C E 120-U/C
26	3,0	20		-	-	EI 120-U/C E 120-U/C
32	3,0	25		-	-	EI 120-U/C E 120-U/C

System Armaflex Protect
- Installation in flexible wall and rigid wall /
fire resistance classification -

ANNEX B-1

electronic copy

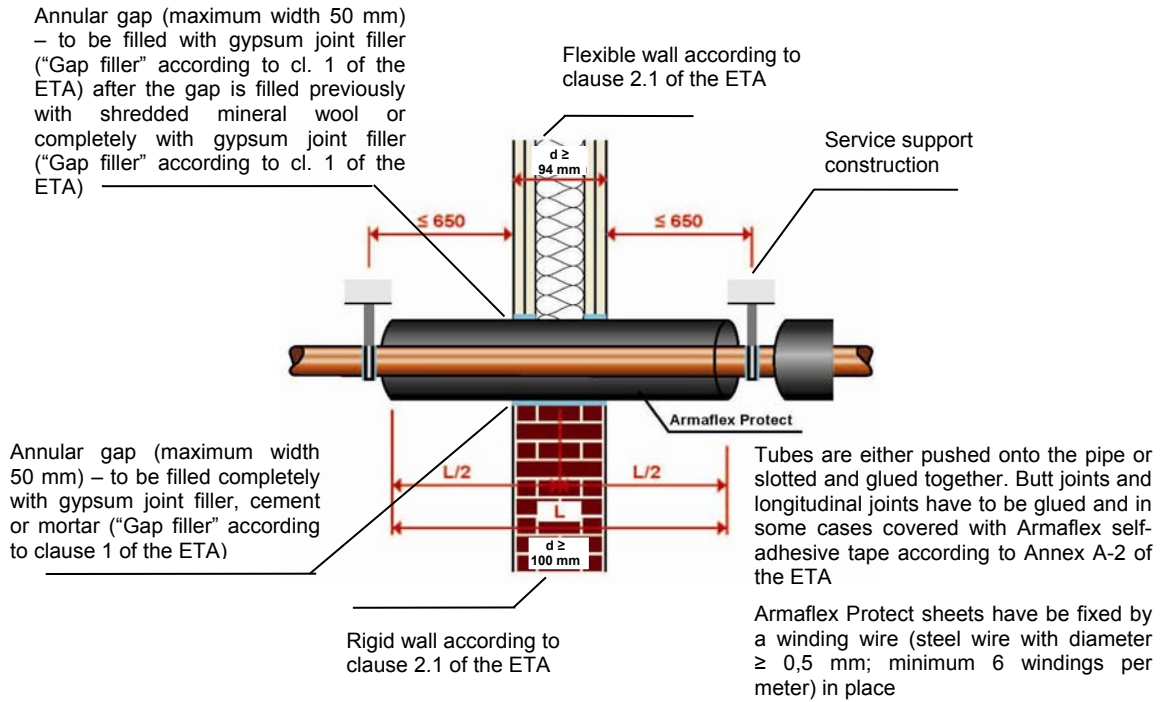

alplex L pipes acc. to cl. 2.1 of the ETA – in flexible walls and rigid walls acc. to cl. 2.1 of the ETA

Pipe dimensions (mm)		Armaflex Protect (local-sustained LS or continued-sustained CS)		AF/Armaflex - continuing insulation		Fire resistance classification
Outer diameter	Wall thickness	Thickness (mm)	Length (mm)	Thickness (mm)	Length (mm)	
40	3,5	25	≥ 500	-	-	EI 120-U/C E 120-U/C
50	4,0	25		-	-	EI 120-U/C E 120-U/C
63	4,5	25		-	-	EI 120-U/C E 120-U/C
75	5,0	25		-	-	EI 120-U/C E 120-U/C

System Armaflex Protect
- Installation in flexible wall and rigid wall /
fire resistance classification -

ANNEX B-2

electronic copy

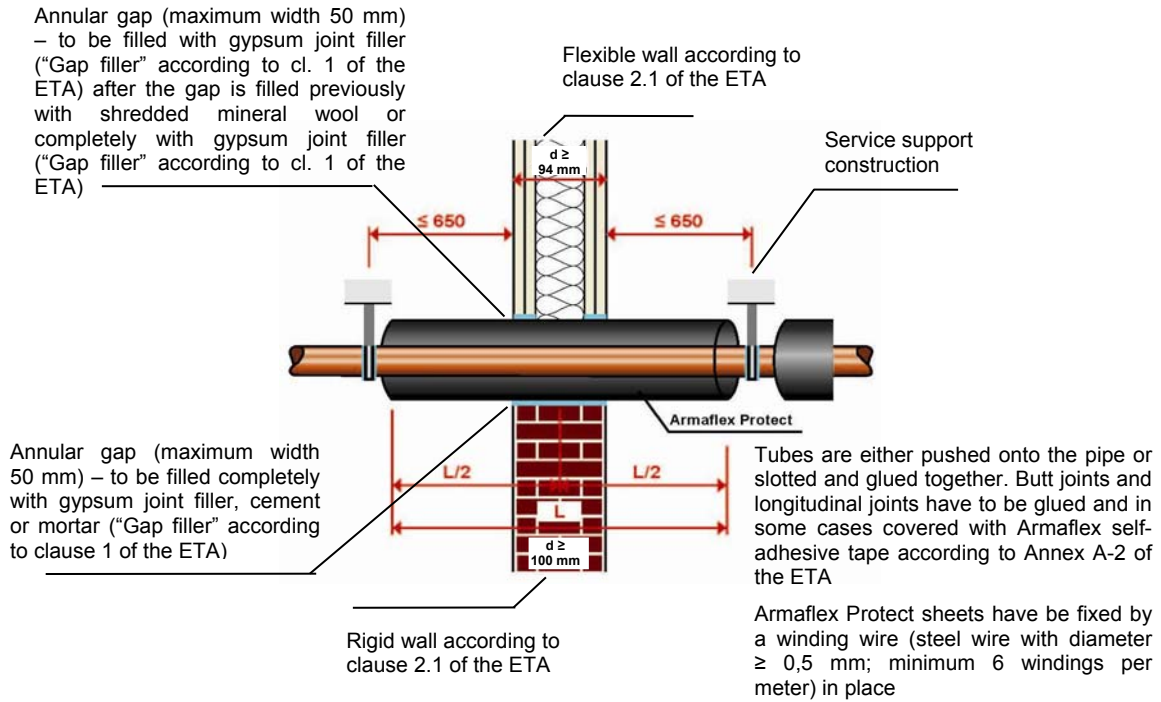

Copper pipes acc. to cl. 2.1 of the ETA – in flexible walls and rigid walls acc. to cl. 2.1 of the ETA

Pipe dimensions (mm)		Armaflex Protect (local-sustained LS or continued-sustained CS)		AF/Armaflex - continuing insulation		Fire resistance classification
Outer diameter	Wall thickness*	Thickness (mm)	Length (mm)	Thickness (mm)	Length (mm)	
≤ 8	$\geq 1,0$	16	≥ 500	-	-	EI 120-C/U E 120-C/U
> 8 to ≤ 15	$\geq 1,0$	19		-	-	EI 90-C/U E 120-C/U
> 15 to ≤ 25	$\geq 1,0$	20		-	-	EI 90-C/U E 120-C/U
> 25 to ≤ 35	$\geq 1,0$	25		-	-	EI 120-C/U E 120-C/U
> 35 to ≤ 42	$\geq 1,5$	25	≥ 1000	-	-	EI 120-C/U E 120-C/U
> 42 to $\leq 88,9$	$\geq 2,0$	25		-	-	EI 120-C/U E 120-C/U
$> 88,9$ to ≤ 108	$\geq 2,5$	25		-	-	EI 90-C/U E 120-C/U

* The maximum wall thickness of the pipe is limited to 14,2 mm

System Armaflex Protect
- Installation in flexible wall and rigid wall /
fire resistance classification -

ANNEX B-3

electronic copy

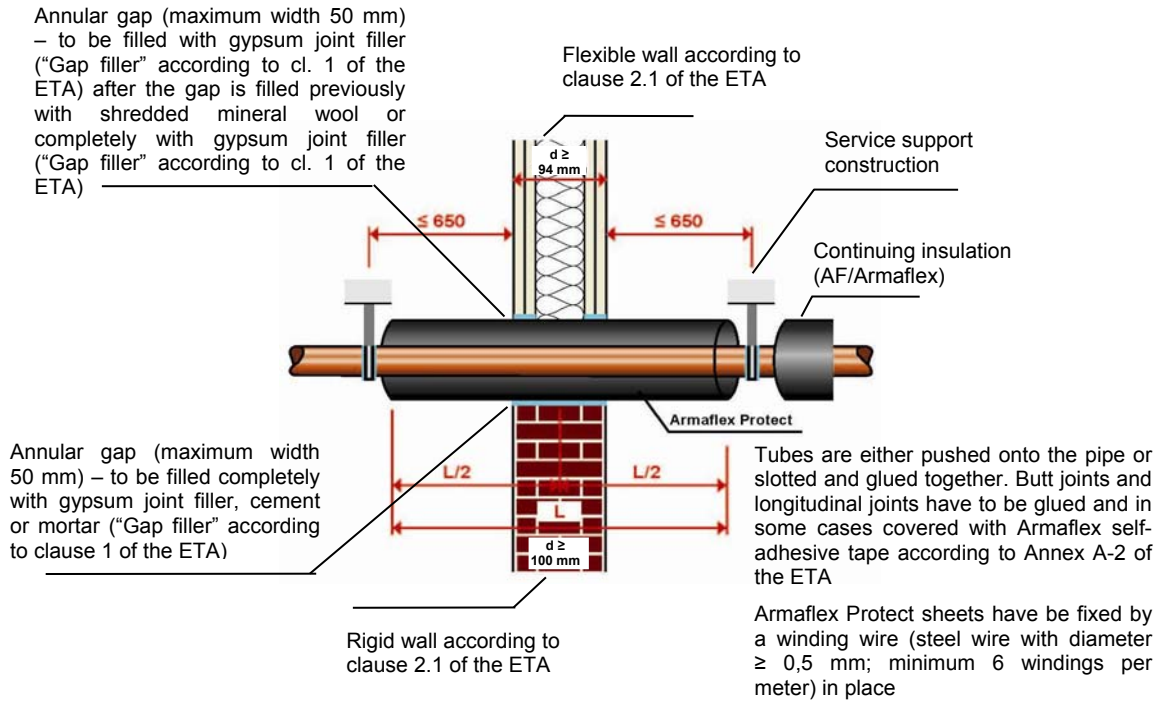

Steel pipes acc. to cl. 2.1 of the ETA – in flexible walls and rigid walls acc. to cl. 2.1 of the ETA

Pipe dimensions (mm)		Armaflex Protect (local-sustained LS)		AF/Armaflex - continuing insulation (continued-sustained CS)		Fire resistance classification
Outer diameter	Wall thickness*	Thickness (mm)	Length (mm)	Thickness (mm)	Length (mm)	
> 108 to ≤ 168,3	≥ 3,0	26	≥ 500	25	≥ 450	EI 45-C/U E 120-C/U

* The maximum wall thickness of the pipe is limited to 14,2 mm

System Armaflex Protect
- Installation in flexible wall and rigid wall /
fire resistance classification -

ANNEX B-4

electronic copy electronic copy electronic copy electronic copy electronic copy electronic copy electronic copy electronic copy electronic copy electronic copy

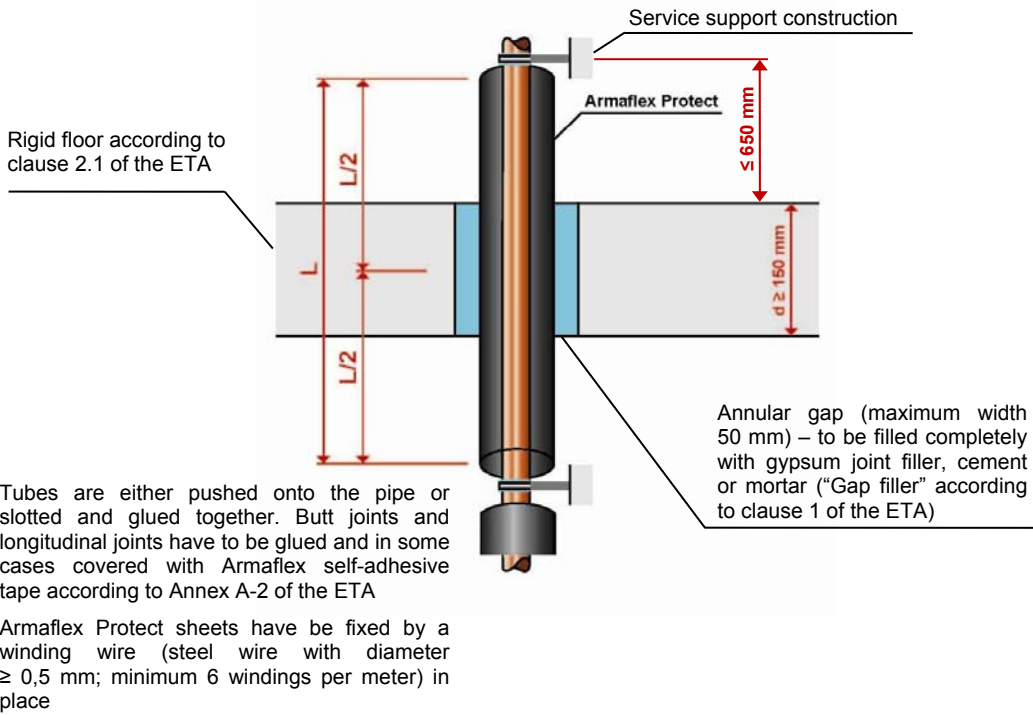

alplex F50 PROFI pipes acc. to cl. 2.1 of the ETA – in rigid floors acc. to cl. 2.1 of the ETA

Pipe dimensions (mm)		Armaflex Protect (local-sustained LS or continued-sustained CS)		AF/Armaflex - continuing insulation		Fire resistance classification
Outer diameter	Wall thickness	Thickness (mm)	Length (mm)	Thickness (mm)	Length (mm)	
16	2,0	20	≥ 500	-	-	EI 120-U/C E 120-U/C
20	2,0	20		-	-	EI 120-U/C E 120-U/C
26	3,0	20		-	-	EI 120-U/C E 120-U/C
32	3,0	25		-	-	EI 90-U/C E 120-U/C

System Armaflex Protect
- Installation in rigid floor /
fire resistance classification -

ANNEX B-5

electronic copy electronic copy electronic copy electronic copy electronic copy electronic copy electronic copy electronic copy electronic copy electronic copy

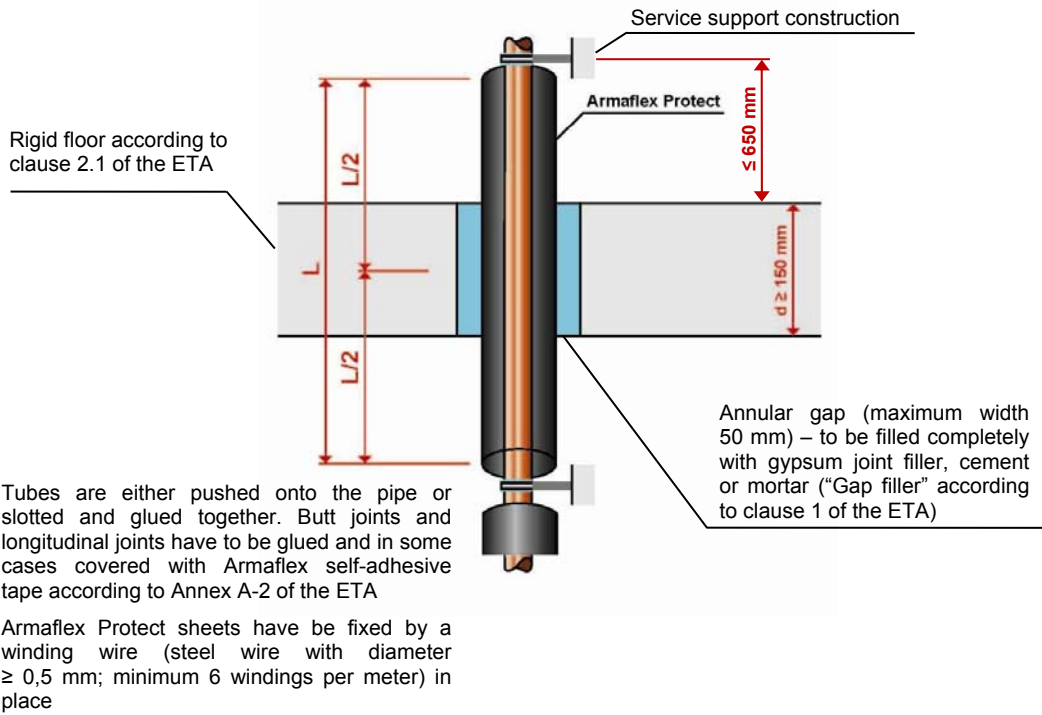

alpex L pipes acc. to cl. 2.1 of the ETA – in rigid floors acc. to cl. 2.1 of the ETA

Pipe dimensions (mm)		Armaflex Protect (local-sustained LS or continued-sustained CS)		AF/Armaflex - continuing insulation		Fire resistance classification
Outer diameter	Wall thickness	Thickness (mm)	Length (mm)	Thickness (mm)	Length (mm)	
40	3,5	25	≥ 500	-	-	EI 120-U/C E 120-U/C
50	4,0	25		-	-	EI 90-U/C E 120-U/C
63	4,5	25		-	-	EI 120-U/C E 120-U/C
75	5,0	25		-	-	EI 120-U/C E 120-U/C

System Armaflex Protect
- Installation in rigid floor /
fire resistance classification -

ANNEX B-6

electronic copy

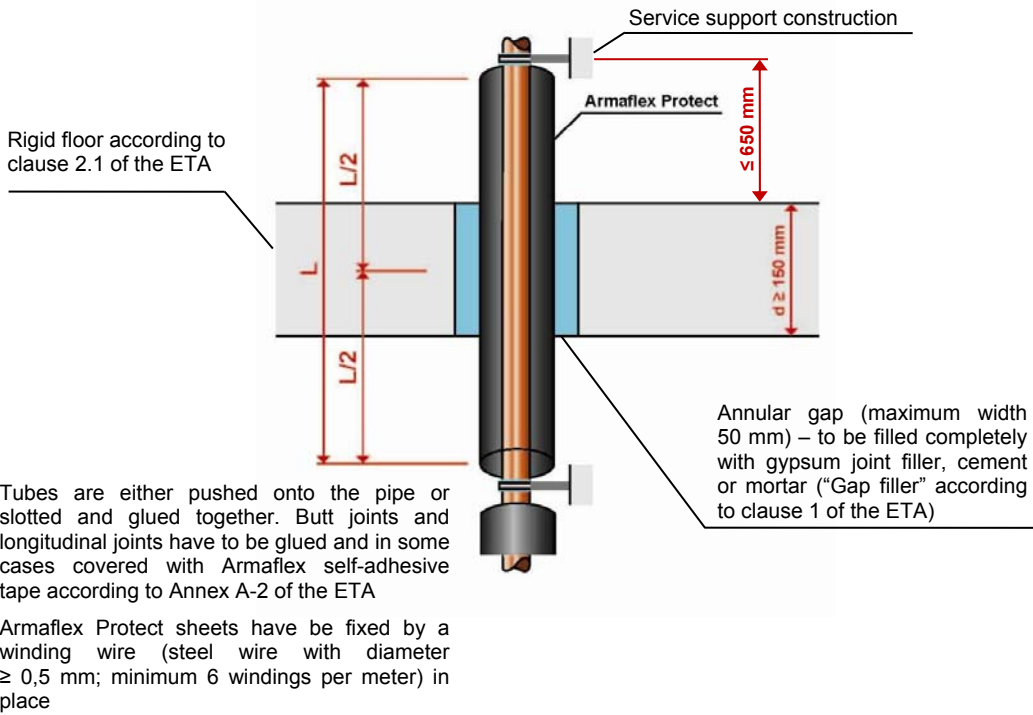

Copper pipes acc. to cl. 2.1 of the ETA – in rigid floors acc. to cl. 2.1 of the ETA

Pipe dimensions (mm)		Armaflex Protect (local-sustained LS or continued-sustained CS)		AF/Armaflex - continuing insulation		Fire resistance classification
Outer diameter	Wall thickness*	Thickness (mm)	Length (mm)	Thickness (mm)	Length (mm)	
≤ 8	$\geq 1,0$	16	≥ 500	-	-	EI 120-C/U E 120-C/U
> 8 to ≤ 15	$\geq 1,0$	19		-	-	EI 120-C/U E 120-C/U
> 15 to ≤ 25	$\geq 1,0$	20		-	-	EI 120-C/U E 120-C/U
> 25 to ≤ 35	$\geq 1,0$	25		-	-	EI 120-C/U E 120-C/U
> 35 to ≤ 42	$\geq 1,5$	25	≥ 1000	-	-	EI 120-C/U E 120-C/U
> 42 to $\leq 88,9$	$\geq 2,0$	25		-	-	EI 120-C/U E 120-C/U

* The maximum wall thickness of the pipe is limited to 14,2 mm

System Armaflex Protect
- Installation in rigid floor /
fire resistance classification -

ANNEX B-7

electronic copy electronic copy electronic copy electronic copy electronic copy electronic copy electronic copy electronic copy electronic copy electronic copy

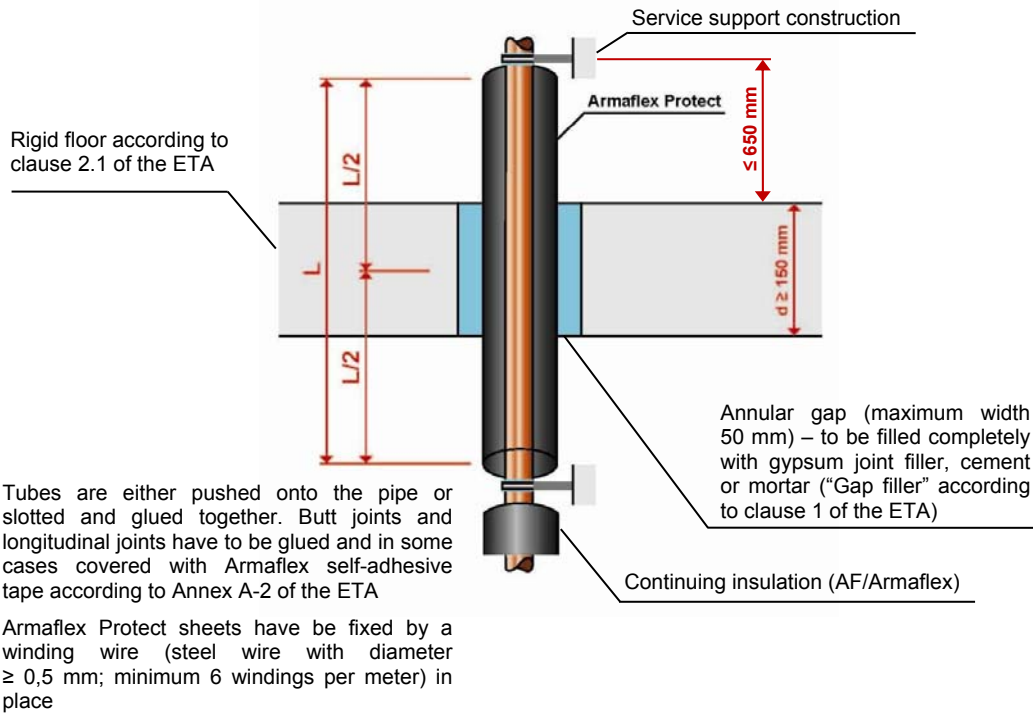

Copper pipes acc. to cl. 2.1 of the ETA – in rigid floors acc. to cl. 2.1 of the ETA

Pipe dimensions (mm)		Armaflex Protect (local-sustained LS)		AF/Armaflex - continuing insulation (continued-sustained CS)		Fire resistance classification
Outer diameter	Wall thickness*	Thickness (mm)	Length (mm)	Thickness (mm)	Length (mm)	
> 88,9 to ≤ 108	≥ 2,5	25	≥ 1000	25	≥ 150	EI 90-C/U E 120-C/U

* The maximum wall thickness of the pipe is limited to 14,2 mm

Steel pipes acc. to cl. 2.1 of the ETA – in rigid floors acc. to cl. 2.1 of the ETA

Pipe dimensions (mm)		Armaflex Protect (local-sustained LS)		AF/Armaflex - continuing insulation (continued-sustained CS)		Fire resistance classification
Outer diameter	Wall thickness*	Thickness (mm)	Length (mm)	Thickness (mm)	Length (mm)	
> 108 to ≤ 168,3	≥ 2,9	26	≥ 500	25	≥ 450	EI 90-C/U E 120-C/U
> 168,3 to ≤ 326	≥ 5,6	26		25	≥ 750	EI 60-C/U E 90-C/U

* The maximum wall thickness of the pipe is limited to 14,2 mm

System Armaflex Protect
- Installation in rigid floor /
fire resistance classification -

ANNEX B-8