



ETA-Danmark A/S
Göteborg Plads 1
DK-2150 Nordhavn
Tel. +45 72 24 59 00
Fax +45 72 24 59 04
Internet www.etadanmark.dk

Authorised and notified according
to Article 29 of the Regulation (EU)
No 305/2011 of the European
Parliament and of the Council of 9
March 2011

MEMBER OF EOTA



European Technical Assessment ETA-07/0212 of 30/08/2015

I General Part

Technical Assessment Body issuing the ETA and designated according to Article 29 of the Regulation (EU) No 305/2011: ETA-Danmark A/S

Trade name of the construction product:

SIMA Angle Brackets type V1, V1Ø7, V2, V2PL, V2 Stainless, V2Ø7, V3, V4, V4PL, V4 Stainless, V6, V7, V7PL, V8, V10 2,5, V10, V12, V13, V14, V15, V20, V21, V26, V27, V170, LV1, P4, P1-8, P1-10, P1-12, P2-10, P2-12, 1-150, K4

Product family to which the above construction product belongs:

Three-dimensional nailing plate (timber-to-timber/timber-to-concrete angle bracket)

Manufacturer:

Sima Industri ApS
Industrivej Nord 40
DK-7490 Aulum
Tel. +45 97 47 26 11
Fax +45 97 47 37 11
Internet www.simaindustri.dk

Manufacturing plant:

Sima Industri ApS
Industrivej Nord 40
DK-7490 Aulum

This European Technical Assessment contains:

54 pages including 3 annexes which form an integral part of the document

This European Technical Assessment is issued in accordance with Regulation (EU) No 305/2011, on the basis of:

Guideline for European Technical Approval (ETAG) No. 015 Three Dimensional Nailing Plates, April 2013, used as European Assessment Document (EAD).

This version replaces:

The previous ETA with the same number issued on 2013-06-26 and expiry on 2015-09-07

Translations of this European Technical Assessment in other languages shall fully correspond to the original issued document and should be identified as such.

Communication of this European Technical Assessment, including transmission by electronic means, shall be in full (excepted the confidential Annex(es) referred to above). However, partial reproduction may be made, with the written consent of the issuing Technical Assessment Body. Any partial reproduction has to be identified as such.

II SPECIFIC PART OF THE EUROPEAN TECHNICAL ASSESSMENT

1 Technical description of product and intended use

Technical description of the product

SIMA Angle Brackets type V1, V1Ø7, V2, V2PL, V2 Stainless, V2Ø7, V3, V4, V4PL, V4 Stainless, V6, V7, V7PL, V8, V10 2,5, V10, V12, V13, V14, V15, V20, V21, V26, V27, V170, LV1, P4, P1-8, P1-10, P1-12, P2-10, P2-12, 1-150 and K4 are one piece, non-welded angle brackets. They are intended for timber-to-timber, timber-to-concrete or timber-to-steel connections fastened by a range of nails or bolts.

Most of the angle brackets are made from pre-galvanized steel Grade S250GD + min. Z275 according to EN 10346.

The angle brackets V2 Stainless and V4 Stainless are made from stainless steel 1.4301, 1.4401, 1.4404, 1.4541 or 1.4571 according to EN 10088-2 with a minimum characteristic yield stress of 235 MPa and a minimum ultimate tensile strength of 330 MPa. Dimensions, hole positions and typical installations are shown in Annex B.

Angle bracket 1-150 are made from steel Grade S235JRG2 according to EN 10025-2 with a corrosion protection of hot dipped galvanized according to EN ISO 1461 with a zinc coating thickness of approximately 55 µm. Additionally all angle brackets can also be made using these specifications.

Additionally, the angle brackets type V2PL can be made from 1,5 mm pre-galvanized steel in grades from Grade S350GD to Grade S500GD + min. Z275 according to EN 10346 and bracket type V4PL can be made from 2,0 mm pre-galvanized steel in grades from Grade S350GD to Grade S500GD + min. Z275 according to EN 10346.

2 Specification of the intended use in accordance with the applicable EAD

The angle brackets are intended for use in making connections in load bearing structures, as a connection between two timber beams or a timber beam and a timber column or between a timber member and a concrete or steel member, where requirements for mechanical resistance and stability and safety in use in the sense of the Basic Works Requirements 1 and 4 of Regulation (EU) 305/2011 shall be fulfilled.

The connection may be with a single angle bracket or

with an angle bracket on each side of the fastened timber member.

The static and kinematic behaviour of the timber members or the supports shall be as described in Annex C.

The wood members can be of solid timber, glued laminated timber and similar glued members, or wood-based structural members with a characteristic density from 290 kg/m³ to 420 kg/m³.

This requirement to the material of the wood members can be fulfilled by using the following materials:

- Solid timber classified to C14-C40 according to EN 338 / EN 14081
- Glued members of timber classified to C14-C40 according to EN 338 / EN 14081 when structural adhesives are used.
- Glued laminated timber classified to GL24c or better according to EN 1194 / EN 14080.
- Solid Wood Panels, SWP according to EN 13353.
- Laminated Veneer Lumber LVL according to EN 14374
- Laminated Strand Lumber, e.g. Parallam and Timber Strand
- Plywood according to EN 636
- Oriented Strand Board, OSB according to EN 300

Annex C states the load-carrying capacities of the Angle Bracket connections for a characteristic density of 350 kg/m³.

For timber or wood based material with a lower characteristic density than 350 kg/m³ the load-carrying capacities shall be reduced by the k_{dens} factor:

$$k_{dens} = \left(\frac{\rho_k}{350} \right)^2$$

Where ρ_k is the characteristic density of the timber in kg/m³.

The design of the connections shall be in accordance with Eurocode 5 or a similar national Timber Code. The wood members shall have a thickness which is larger than the penetration depth of the nails into the members.

The angle brackets may also be used for connections between a timber member and a member of concrete, steel or masonry.

The Angle brackets are primarily for use in timber structures subject to the dry, internal conditions defined by service class 1 and 2 of Eurocode 5, and for connections subject to static or quasi-static loading.

The angle brackets can also be used in outdoor timber

structures, service class 3, when a corrosion protection in accordance with Eurocode 5 is applied, or when stainless steel with similar or better characteristic yield and ultimate strength is employed.

The scope of the brackets regarding resistance to corrosion shall be defined according to national provisions that apply at the installation site considering environmental conditions.

The provisions made in this European Technical Assessment are based on an assumed intended working life of the connectors of 50 years.

The indications given on the working life cannot be interpreted as a guarantee given by the producer or Assessment Body, but are to be regarded only as a means for choosing the right products in relation to the expected economically reasonable working life of the works.

3 Performance of the product and references to the methods used for its assessment

Characteristic	Assessment of characteristic
3.1 Mechanical resistance and stability*) (BWR1)	
Characteristic load-carrying capacity	See Annex C
Stiffness	No performance determined
Ductility in cyclic testing	No performance determined
3.2 Safety in case of fire (BWR2)	
Reaction to fire	The angle brackets are made from steel classified as Euroclass A1 in accordance with EN 1350-1 and EC decision 96/603/EC, amended by EC Decision 2000/605/EC
3.3 Hygiene, health and the environment (BWR3)	
Influence on air quality	The product does not contain/release dangerous substances specified in TR 034, dated March 2012 0**)
3.7 Sustainable use of natural resources (BWR7)	
	No Performance Determined
3.8 General aspects related to the performance of the product	
	The angle brackets have been assessed as having satisfactory durability and serviceability when used in timber structures using the timber species described in Eurocode 5 and subject to the conditions defined by service class 1, 2 and 3
Identification	See Annex B

*) See additional information in section 3.8 – 3.9.

**) In addition to the specific clauses relating to dangerous substances contained in this European technical Assessment, there may be other requirements applicable to the products falling within its scope (e.g. transposed European legislation and national laws, regulations and administrative provisions). In order to meet the provisions of the Construction Products Regulation, these requirements need also to be complied with, when and where they apply.

3.9 Methods of verification

The characteristic load-carrying capacities have been calculated without considering different ratios between the partial factors for timber connections and steel cross sections. Therefore, in the end use calculation based on this ETA, this shall be considered.

The values in annex C have been determined by multiplying the calculated resistance of the connection by k_{mod} to consider load duration and service classes in accordance with EC 5.

3.10 Mechanical resistance and stability

See annex C for characteristic load-carrying capacity in the different directions F_1 to F_5 .

The characteristic capacities of the angle brackets are determined by calculation assisted by testing as described in the EOTA Guideline 015 clause 5.1.2. They should be used for designs in accordance with Eurocode 5 or a similar national Timber Code.

Connector nails in accordance to ETA-09/0273

The load bearing capacities of the brackets have been determined based on the use of Paslode Connector nails 4,0 x 40 mm and 4,0 x 60 mm in accordance with the ETA-09/0273 for the nails. The fastener can be replaced by fastener mentioned in the ETA-09/0273 with the same or higher performance. The capacity of the connection may not be higher than the load mentioned in this ETA.

The capacity of the nails used in calculation are:

$$F_{ax,Rk} = 1,027 \text{ kN}$$
$$F_{v,Rk} = 1,877 \text{ kN}$$

Calculations made before 2015 are based on the following nail values from an older version of ETA-09/0273:

$$F_{ax,Rk} = 0,998 \text{ kN}$$
$$F_{v,Rk} = 1,885 \text{ kN}$$

The angle bracket is mounted using one specific nail patterns for each of the load directions.

No performance has been determined in relation to ductility of a joint under cyclic testing. The contribution to the performance of structures in seismic zones, therefore, has not been assessed.

No performance has been determined in relation to the joint's stiffness properties - to be used for the analysis of the serviceability limit state.

3.11 Aspects related to the performance of the product

3.11.1 Corrosion protection in service class 1 and 2.
In accordance with ETAG 015 the angle bracket has a zinc coating weight of Z275. The steel employed is S250GD with Z275, S350GD with Z275 or S500GD with Z275, both according to EN 10346.

3.11.2 Corrosion protection in service class 3
In accordance with Eurocode 5 the angle brackets made from stainless steel 1.4301, 1.4401, 1.4404, 1.4541 and/or 1.4571 according to EN 10088-2 and the nails or bolts shall be produced from stainless steel. Products which are hot dipped galvanized according to EN ISO 1461 with a zinc coating thickness of approximately 55 μm are intended for use in service class 1, 2 and 3 according to EN 1995 (Eurocode 5).

3.12 General aspects related to the fitness for use of the product

SIMA Industri connectors are manufactured in accordance with the provisions of this European Technical Assessment using the manufacturing processes as identified in the inspection of the plant by the notified inspection body and laid down in the technical documentation.

The nailing pattern used shall be either the maximum or the minimum pattern as defined in Annex B.

Wane under the flaps of the angle bracket is allowed provided it does not occur under the nails. Wane can reduce the load-bearing capacity of the connection.

A gap between the connector and the timber member is not allowed. However, where the angle bracket is used for a connection between a beam and a column a gap of 5 mm is allowed.

4 Attestation and verification of constancy of performance (AVCP)

4.1 AVCP system

According to the decision 97/638/EC of the European Commission¹, as amended, the system(s) of assessment and verification of constancy of performance (see Annex V to Regulation (EU) No 305/2011) is 2+.

5 Technical details necessary for the implementation of the AVCP system, as foreseen in the applicable EAD

Technical details necessary for the implementation of the AVCP system are laid down in the control plan deposited at ETA-Danmark

Issued in Copenhagen on 2015-08-30 by

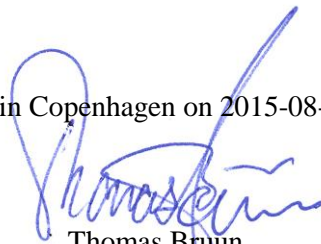

Thomas Bruun
Managing Director, ETA-Danmark

Annex A
Changes from last ETA

Additions and modifications for this ETA	
Pages	Update
	ETA extended
3	Note about stainless steel and hot dipped galvanized added
6	New nail values
12	V1-1 removed
18	Renamed V10 to V10 2,5
17-43	V8 added
18-44	V10 added
21-47	V20 added
22-49	V26 and V27 added
23-53	V170 added
30-56	Characteristic values added to all load carrying value tables

Additions and modifications for the ETA valid from 2013-06-26 to 2015-09-07	
Pages	Update
10	Annex A added
30-56	Formula for F4/F5 directions optimised through the ETA
12,14 and 33,36	V1Ø7 and V2Ø7 added
17,18 and 42,44	V7PL and V10 2,5 added
12	Angle V1 added with smaller height
12-27	Colored hole patterns

Additions and modifications for the ETA valid from 2012-09-07 to 2015-09-07	
Pages	Update
33-35 and 39-41	V2PL and V4PL edited
27 and 51-52	1-150 and K4 added
21,24 and 48-51	V21 and P4 added

Additions and modifications for the ETA valid from 2010-04-09 to 2015-04-09	
Pages	Update
33-3513 and 3139-41	V2PL and V4PL added

Annex B
Product details and definitions

Table A1 Fastener specification

Nail, screw and bolt type	Nail and screw size (mm)		Finish	ETA
	Diameter	Length		
Paslode Connector nail	4,0	40	Electroplated zinc	09/0273
Paslode Connector nail	4,0	60	Electroplated zinc	09/0273
Bolt M8	8		For relevant angle brackets see the assumed characteristic capacities of the bolt connection and compare with the specification of the manufacturer	
Bolt M10	10			
Bolt M12	12			
Hexagon head wood screw	6	40		

Connector specification:

Holes marked blue and green are used in case of optimal nailing

Holes marked yellow are used in case of bolting

Angle bracket V1, V2, V2PL, V3, V4 and V4PL are marked with numbers referenced from Annex C

V2

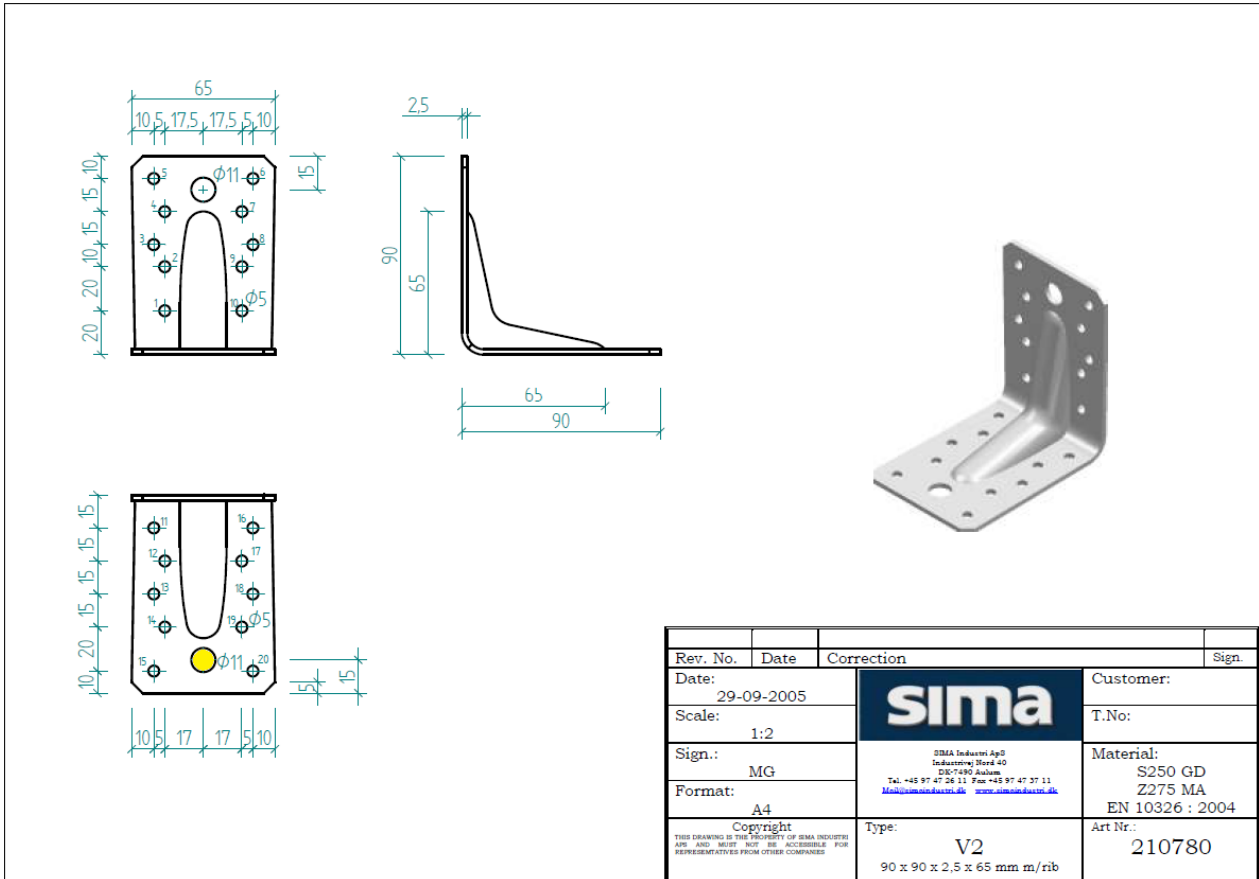

Additionally, the angle brackets type V2 can be made from 1,5 mm pre-galvanized steel in grades from Grade S350GD to Grade S500GD + min. Z275 according to EN 10346 named V2PL

V2 Stainless

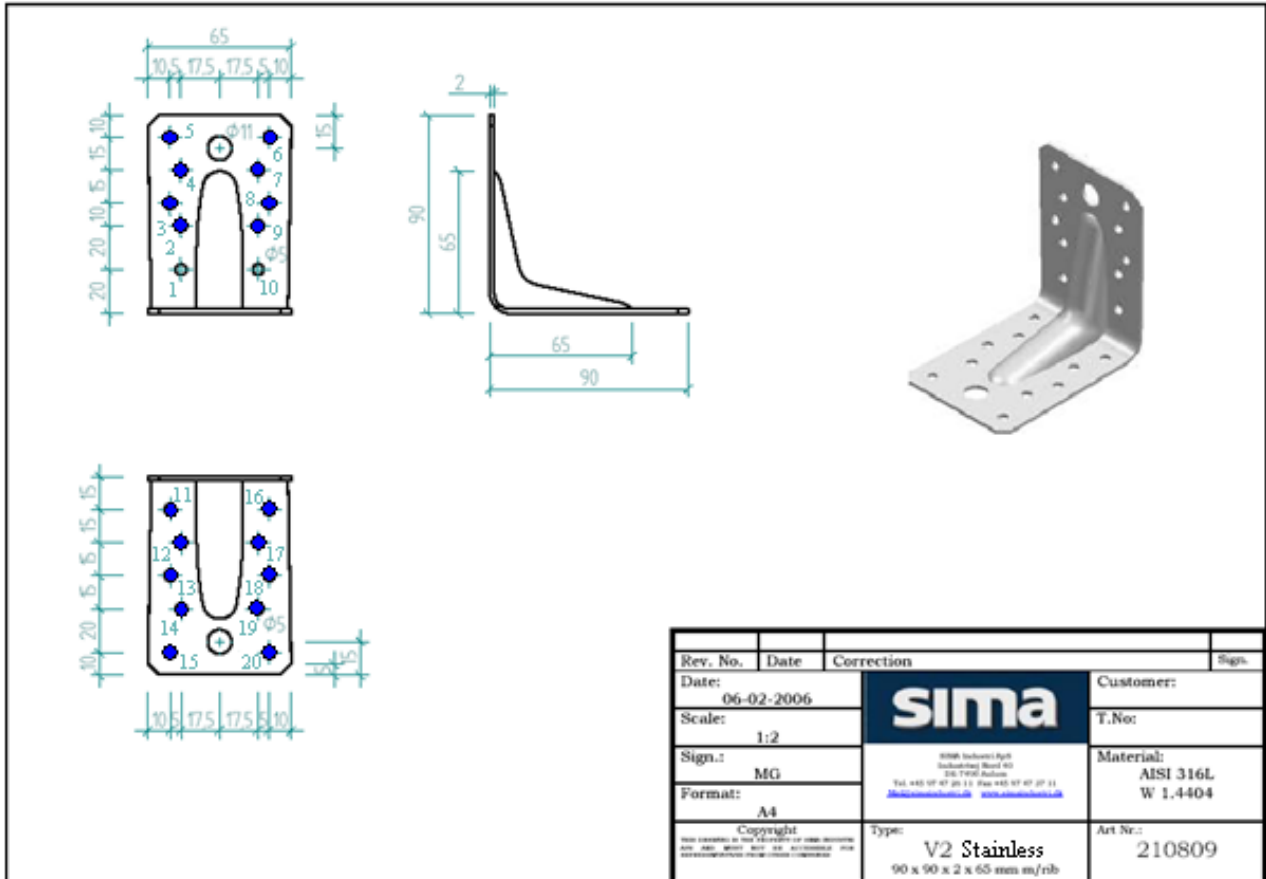

V2Ø7

Technical drawing of V2Ø7 anchor bracket. The drawing includes three views: a front view, a side view, and a perspective view. The front view shows a rectangular plate with a central slot and four circular holes. Dimensions include a total width of 65 mm and a total height of 40 mm. The side view shows a thickness of 2.5 mm and a height of 90 mm. The perspective view shows the L-shaped profile of the bracket.

Date:	20-12-2012	Sima	Tolerances:	ISO-2768m
Scale:	1:2		Weight:	202 g
Sign:	KHD	a strong connection SIMA Industri AG Industriweg Nord 40 D-71495 Aulendorf Tel. +49 97 47 26 11 Fax +49 97 47 37 11 mailto:sima@simasysteme.de www.simasysteme.de	Material:	S250GD Z275MA
Format:	A4		Type:	V2Ø7 90 x 90 x 2,5 x 65 mm W/rib
Copyright THIS DRAWING IS PROPERTY OF SIMA INDUSTRIE AGS AND MUST NOT BE ACCESSIBLE FOR REPRESENTATIVES FROM OTHER COMPANIES				

V3

Technical drawing of V3 anchor bracket. The drawing includes three views: a front view, a side view, and a perspective view. The front view shows a rectangular plate with a central slot and 24 circular holes. Dimensions include a total width of 105 mm and a total height of 105 mm. The side view shows a thickness of 3 mm. The perspective view shows the L-shaped profile of the bracket.

Rev. No.	Date	Correction	Sign.
Date:	29-09-2005	Sima	Customer:
Scale:	1:2		T.No:
Sign.:	MG	SIMA Industri AG Industriweg Nord 40 D-71495 Aulendorf Tel. +49 97 47 26 11 Fax +49 97 47 37 11 mailto:sima@simasysteme.de www.simasysteme.de	Material:
Format:	A4		Type:
Copyright THIS DRAWING IS THE PROPERTY OF SIMA INDUSTRIE AGS AND MUST NOT BE ACCESSIBLE FOR REPRESENTATIVES FROM OTHER COMPANIES		Art Nr.:	
		V3 105 x 105 x 3 x 90 mm	
		210781	

V4

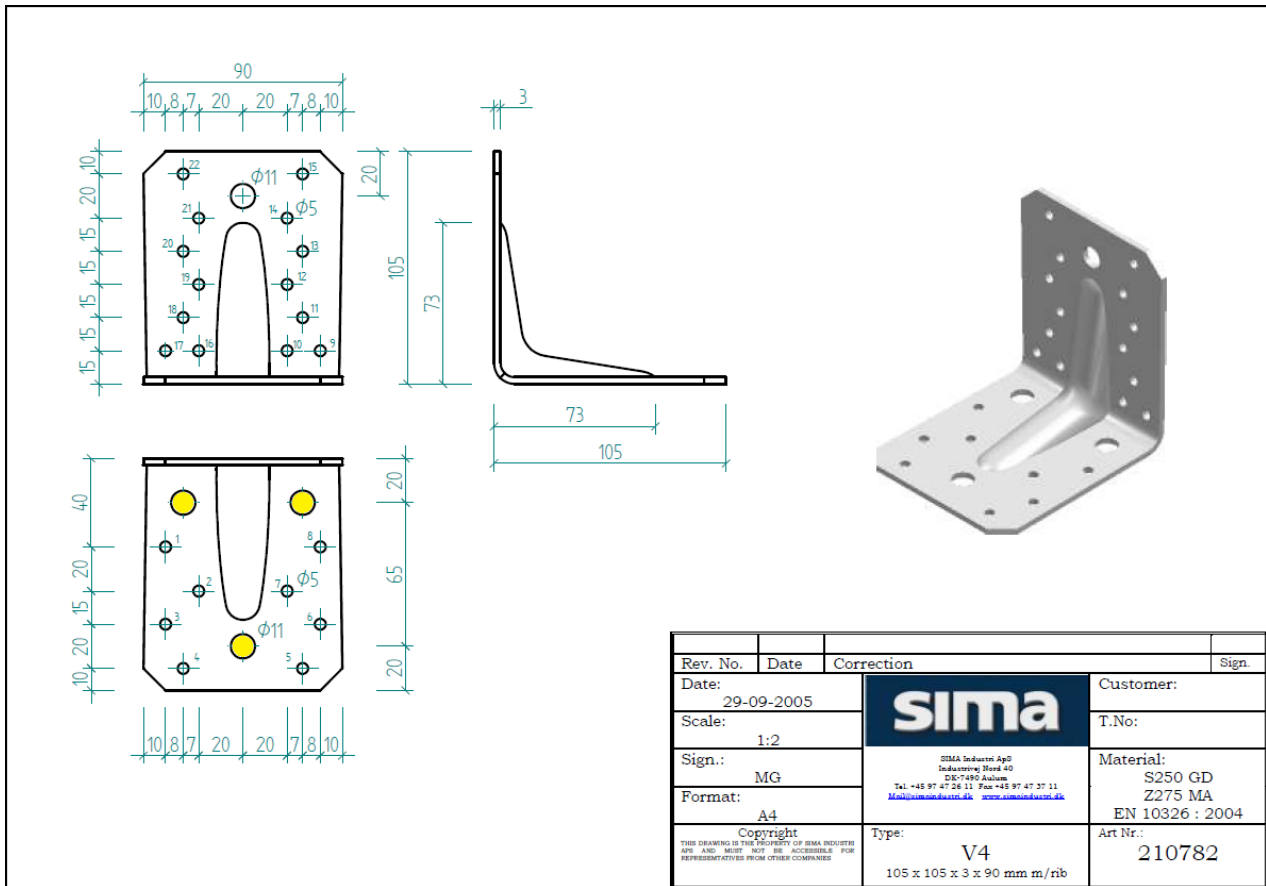

Additionally, the bracket type V4 can be made from 2,0 mm pre-galvanized steel grades from Grade S350GD to Grade S500GD + min. Z275 according to EN 10346 named V4PL

V4 Stainless

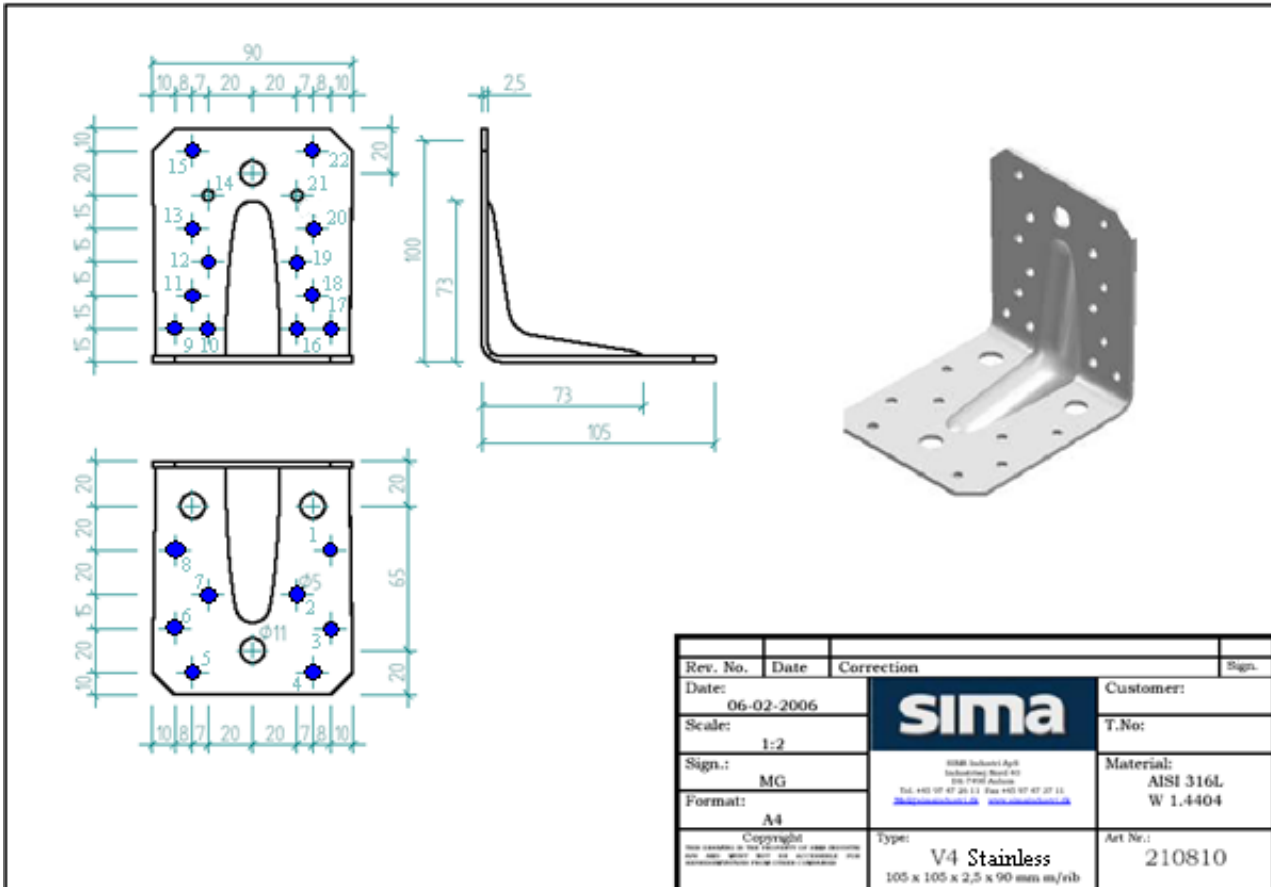

V6

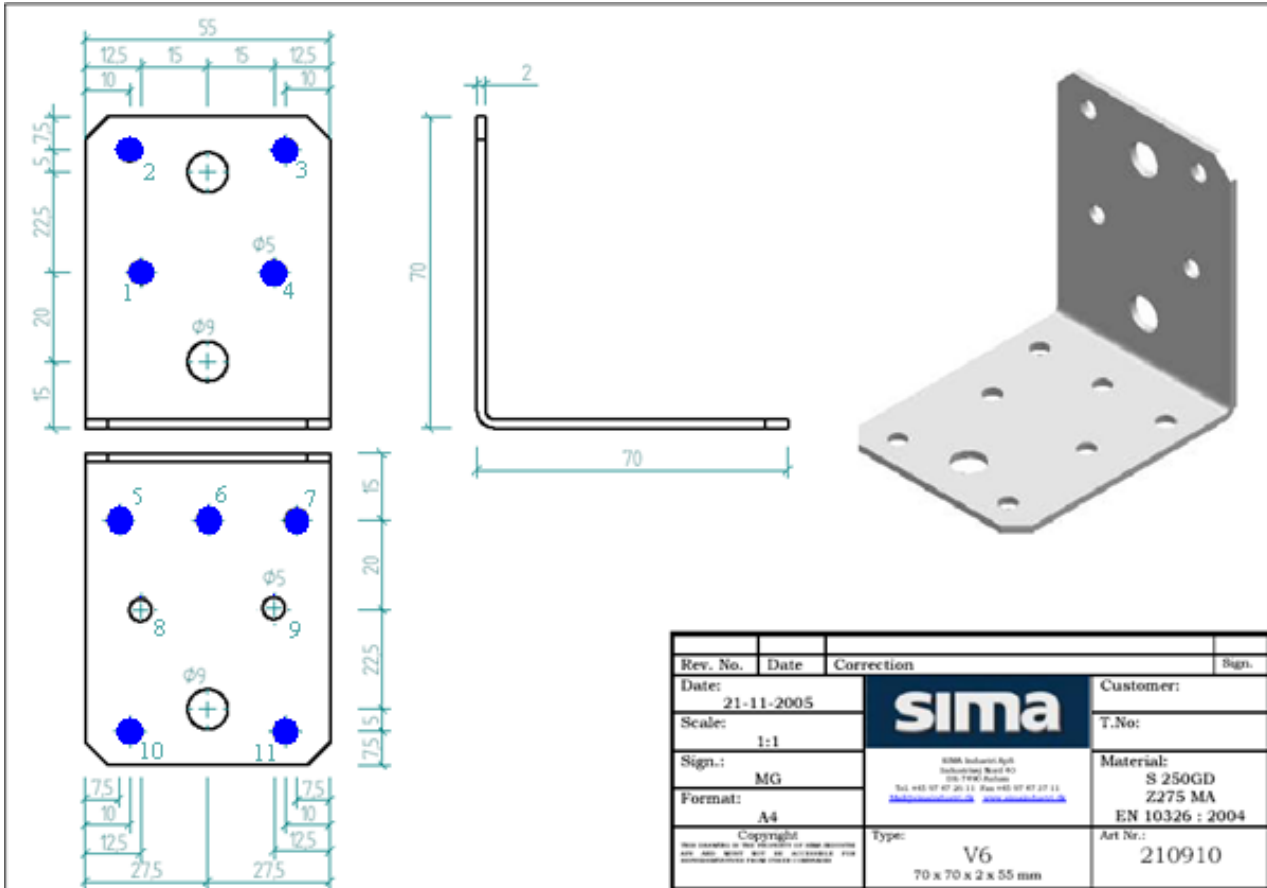

V7

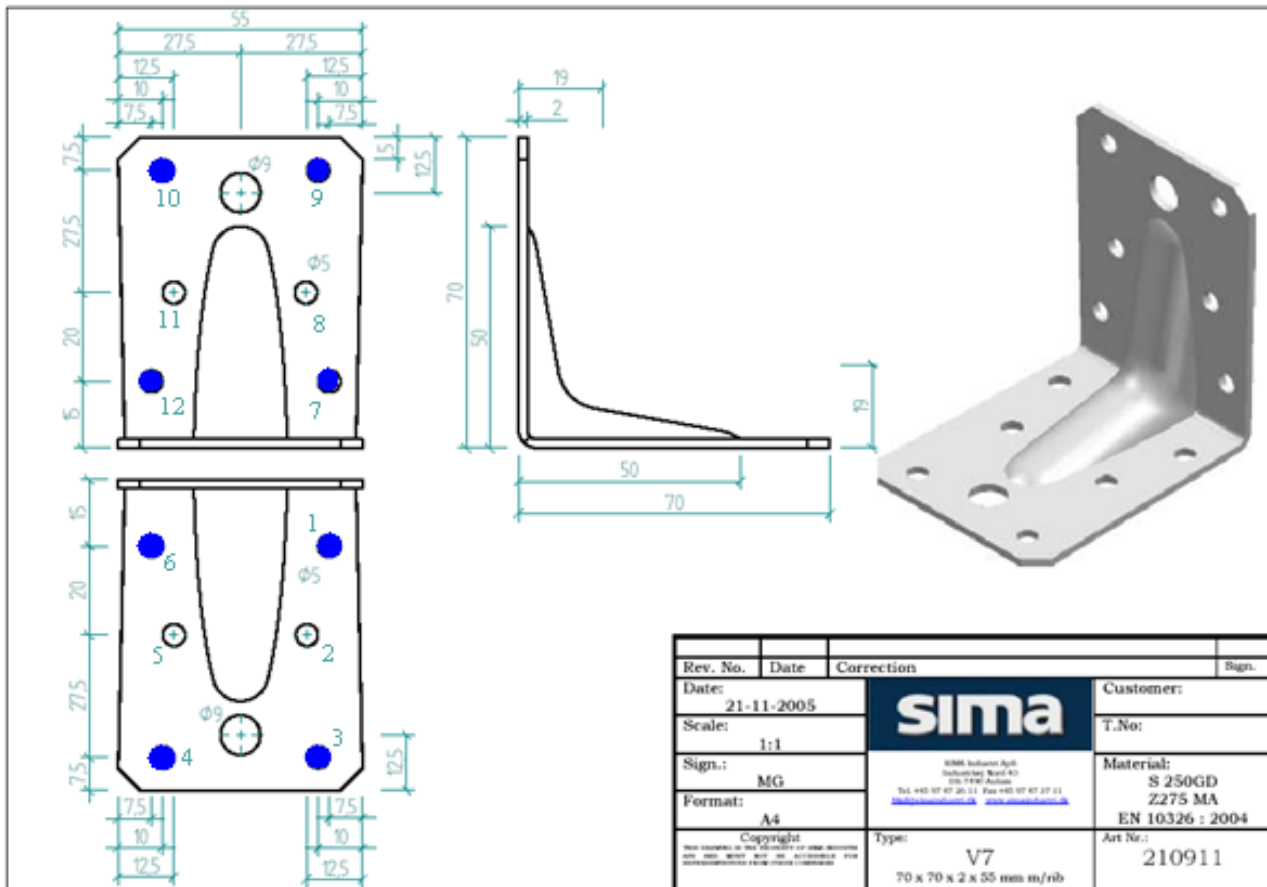

V7PL

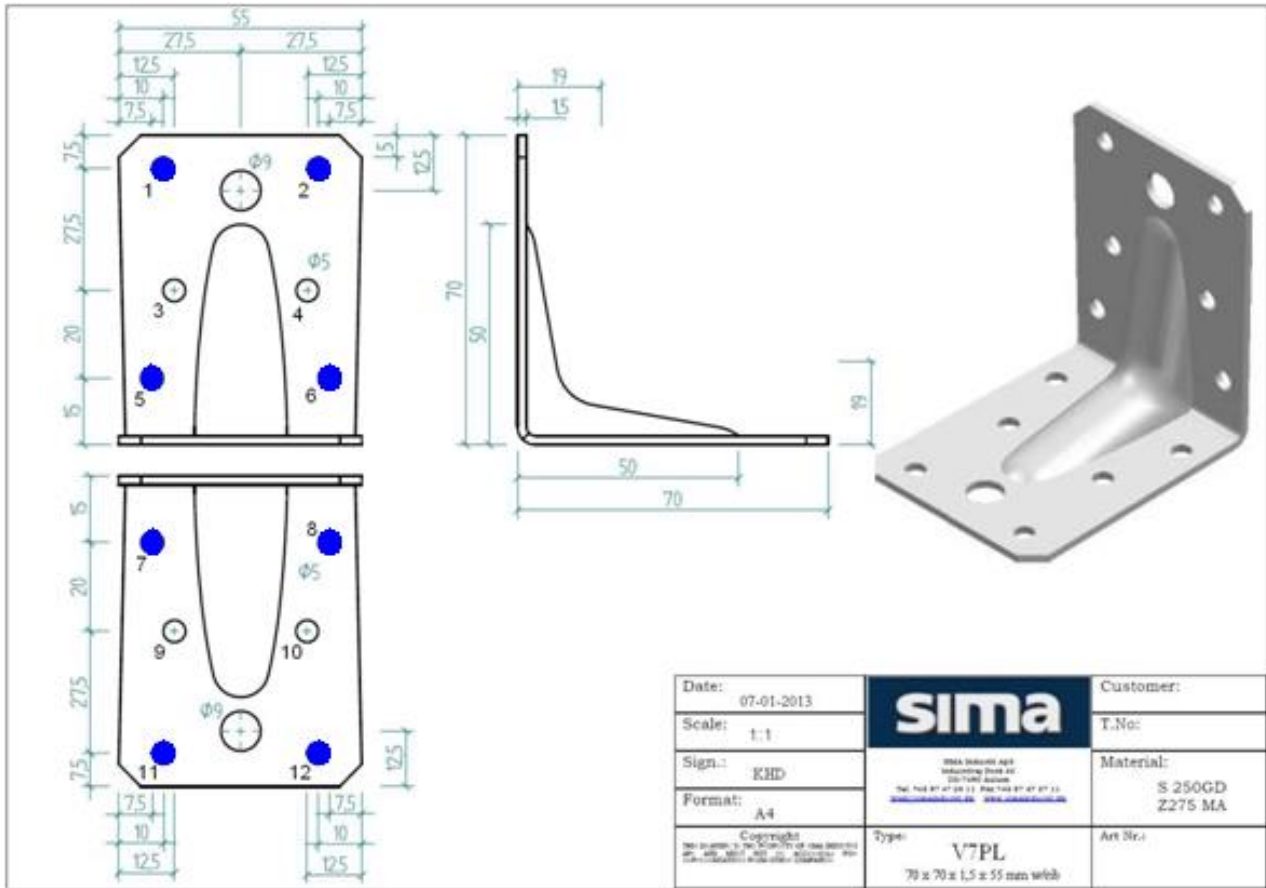

V8

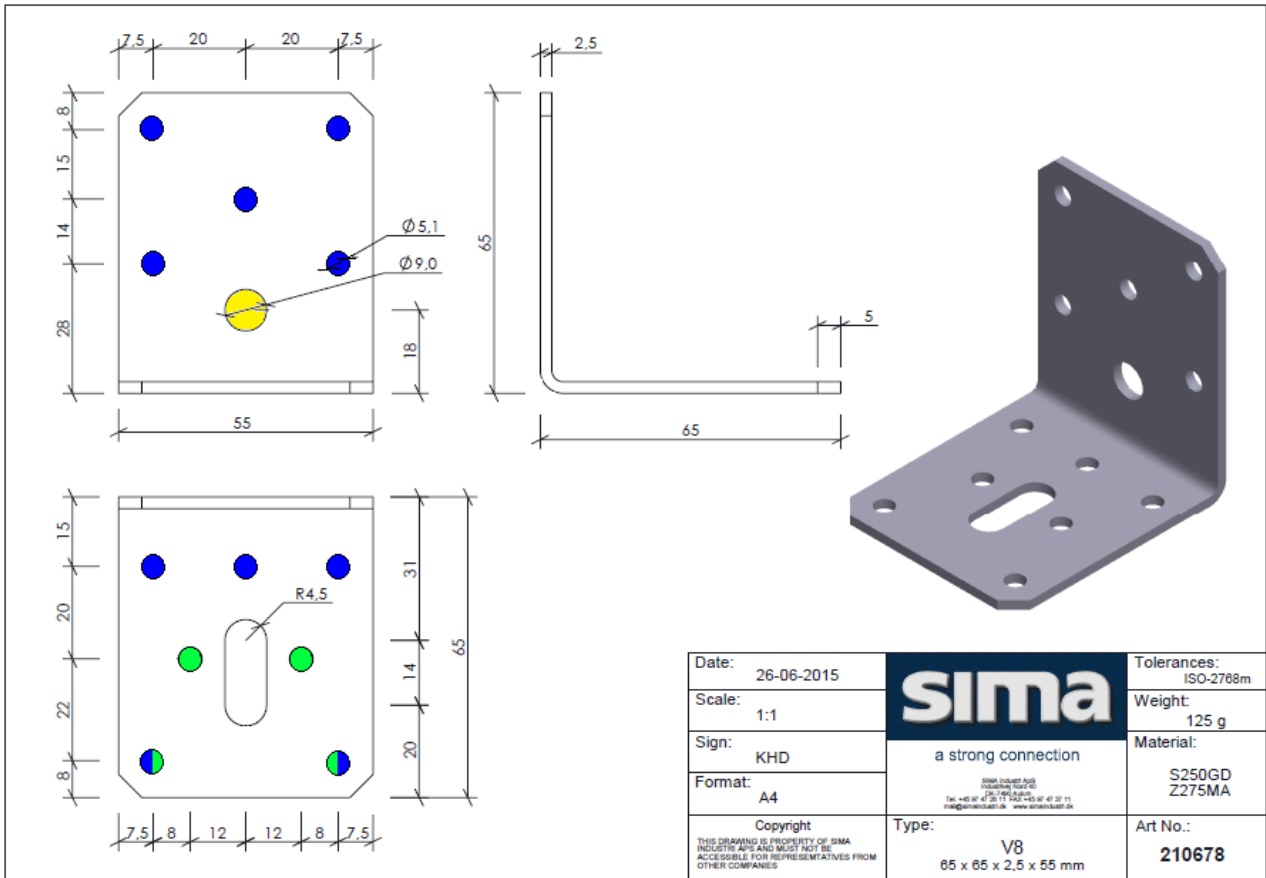

V10 2,5

Technical drawing of V10 2,5 bracket. The drawing includes three views: a front view with dimensions (40, 10, 10, 10, 10, 26, 8, 36, 20, 17, 22.5, 13.5, 14, 12, 11, 17, 20, Ø11.0, Ø5.0), a side view with dimensions (90, 2.5, 90), and a perspective view. The front view shows a 40x17 mm plate with a 2.5 mm thickness, featuring four Ø11.0 mm holes and four Ø5.0 mm holes. The side view shows the 90x90 mm dimensions and the 2.5 mm thickness. The perspective view shows the L-shaped bracket.

Date:	07-12-2012	sima	Tolerances:	ISO-2768m
Scale:	1:2		Weight:	125 g
Sign:	KHD	a strong connection <small>SIMA Industri AG Industriweg Nord 40 D-7460 Arzheim Tel. +49 97 47 20 11 FAX +49 97 47 37 11 mailto:sima@simasoft.de www.simasoft.de</small>	Material:	S250GD Z275MA
Format:	A4		Type:	V10 2,5 90 x 90 x 2,5 x 40 mm
Copyright <small>THIS DRAWING IS PROPERTY OF SIMA INDUSTRI AG'S AND MUST NOT BE ACCESSIBLE FOR REPRESENTATIVES FROM OTHER COMPANIES</small>				

V10

Technical drawing of V10 bracket. The drawing includes three views: a front view with dimensions (10, 10, 10, 10, 8, 17, 17.5, 18.5, 9, 17, 36, 26, 11, 15, 40), a side view with dimensions (90, 3, 90), and a perspective view. The front view shows a 40x17 mm plate with a 3 mm thickness, featuring four Ø11.0 mm holes and four Ø5.0 mm holes. The side view shows the 90x90 mm dimensions and the 3 mm thickness. The perspective view shows the L-shaped bracket.

Date:	08-05-2015	sima	Tolerances:	ISO-2768m
Scale:	1:2		Weight:	156 g
Sign:	KHD	a strong connection <small>SIMA Industri AG Industriweg Nord 40 D-7460 Arzheim Tel. +49 97 47 20 11 FAX +49 97 47 37 11 mailto:sima@simasoft.de www.simasoft.de</small>	Material:	S250GD Z275MA
Format:	A4		Type:	V10 90 x 90 x 3 x 40 mm
Copyright <small>THIS DRAWING IS PROPERTY OF SIMA INDUSTRI AG'S AND MUST NOT BE ACCESSIBLE FOR REPRESENTATIVES FROM OTHER COMPANIES</small>				

V12

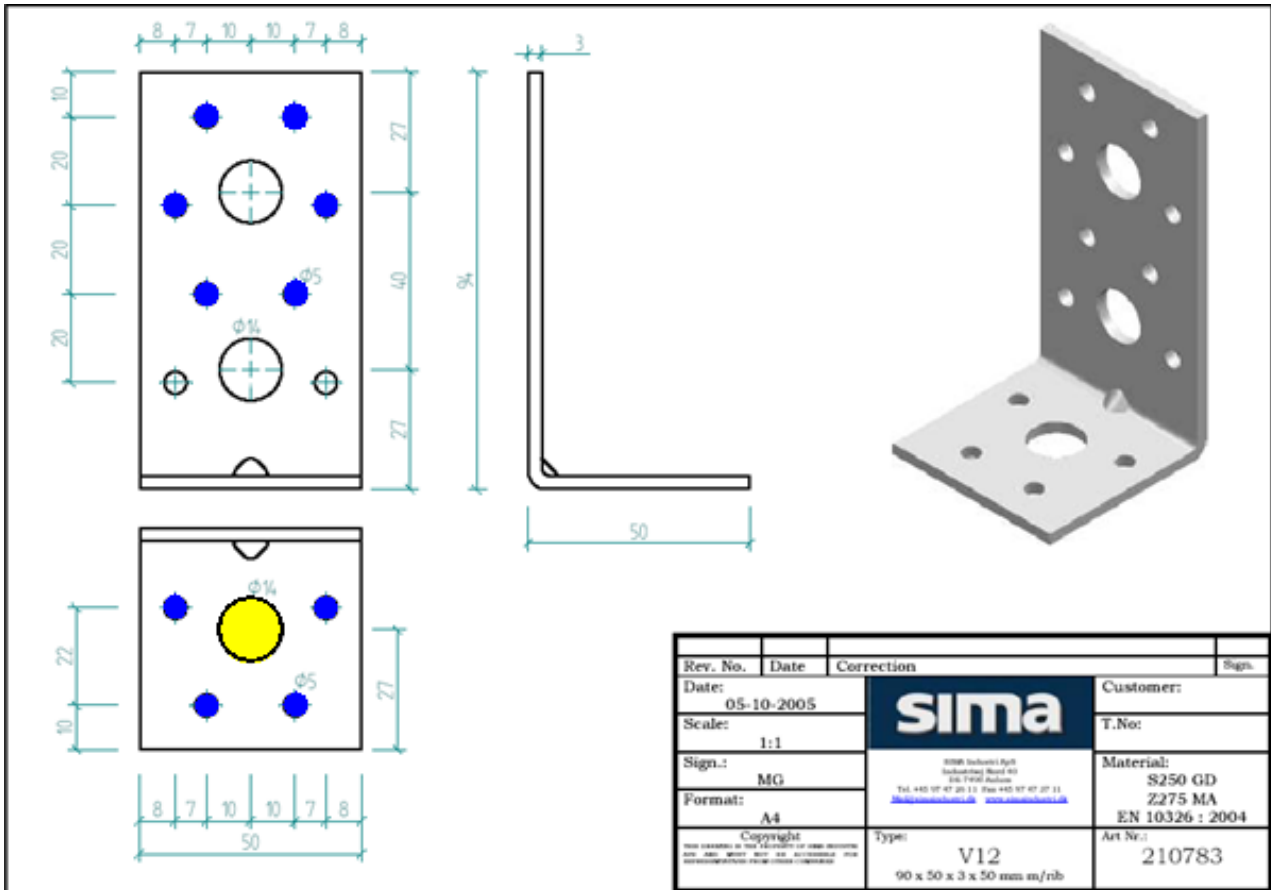

V13

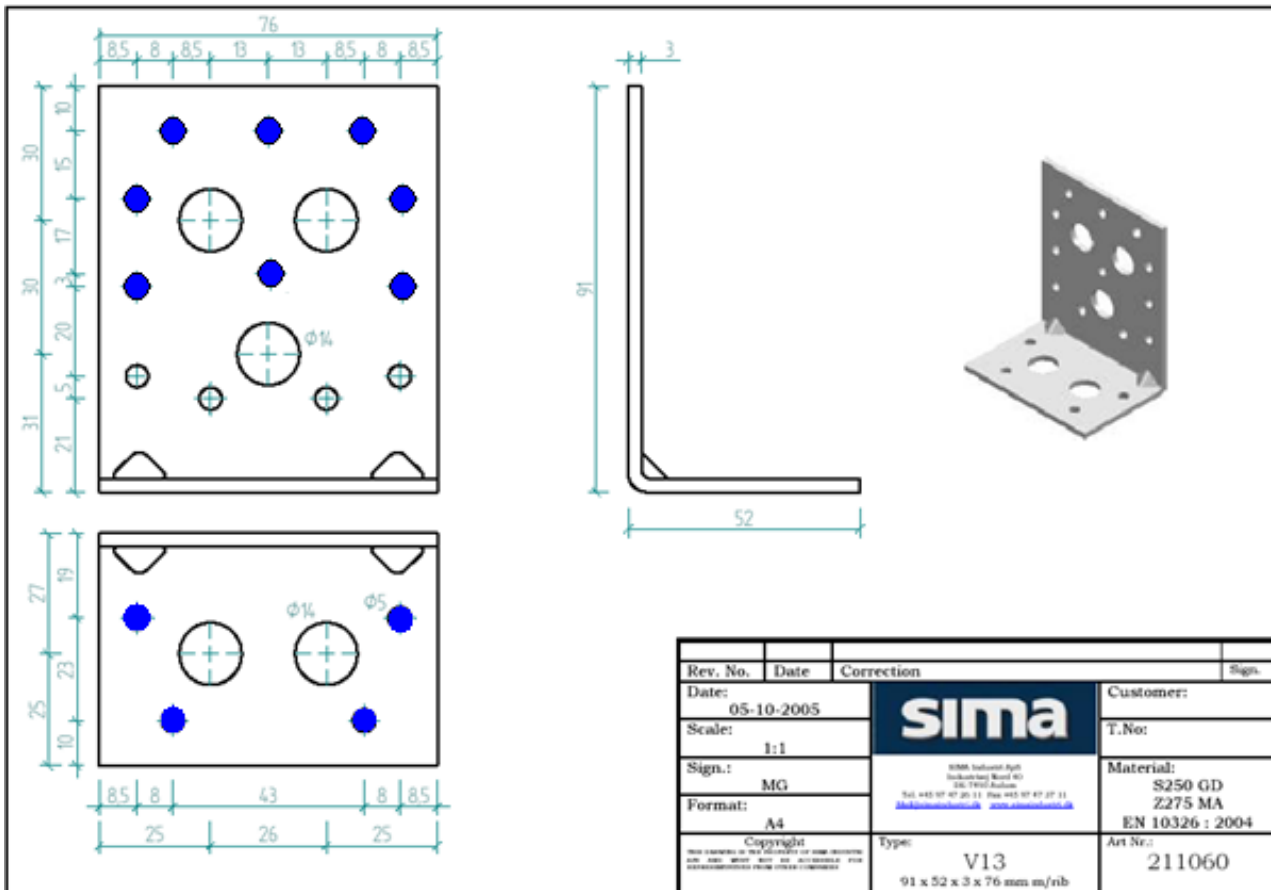

V14

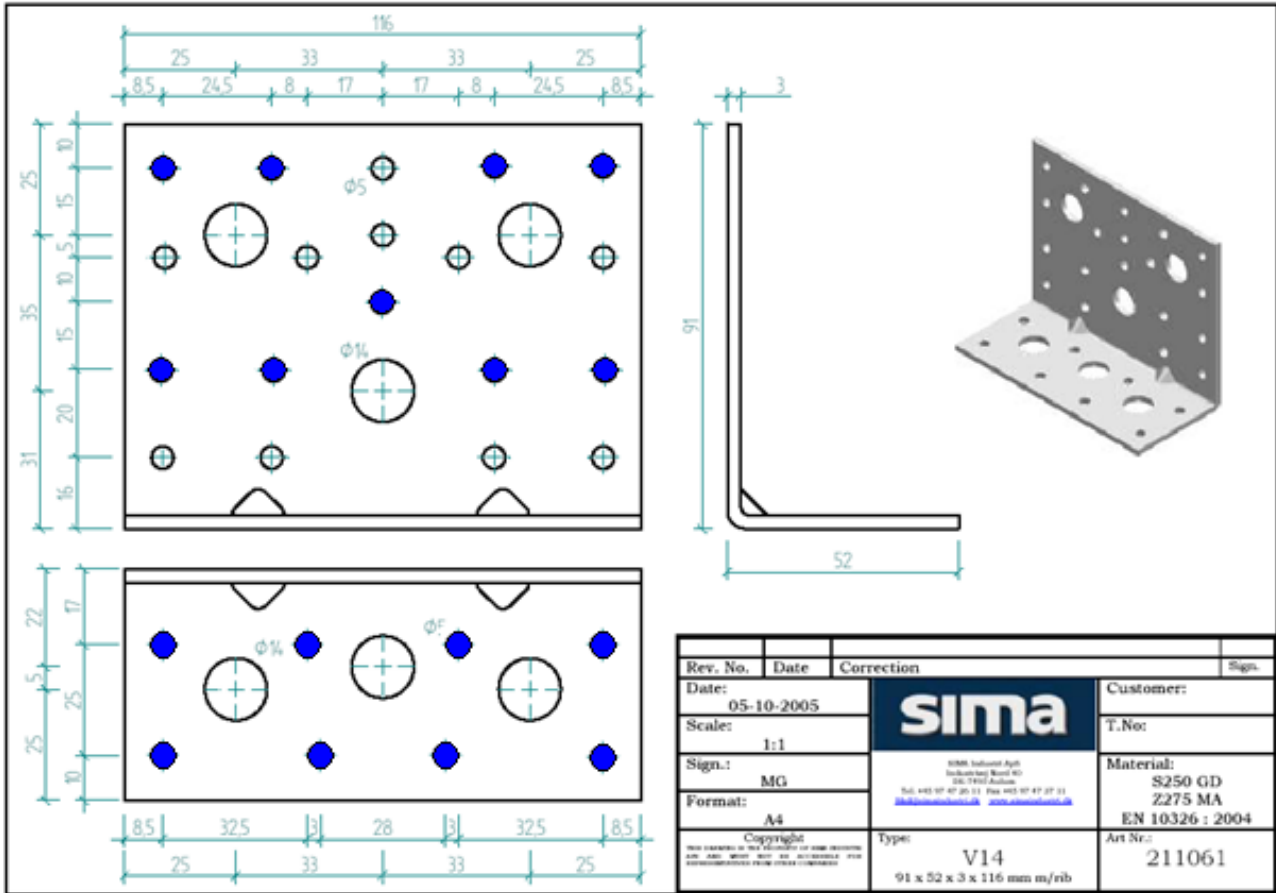

V15

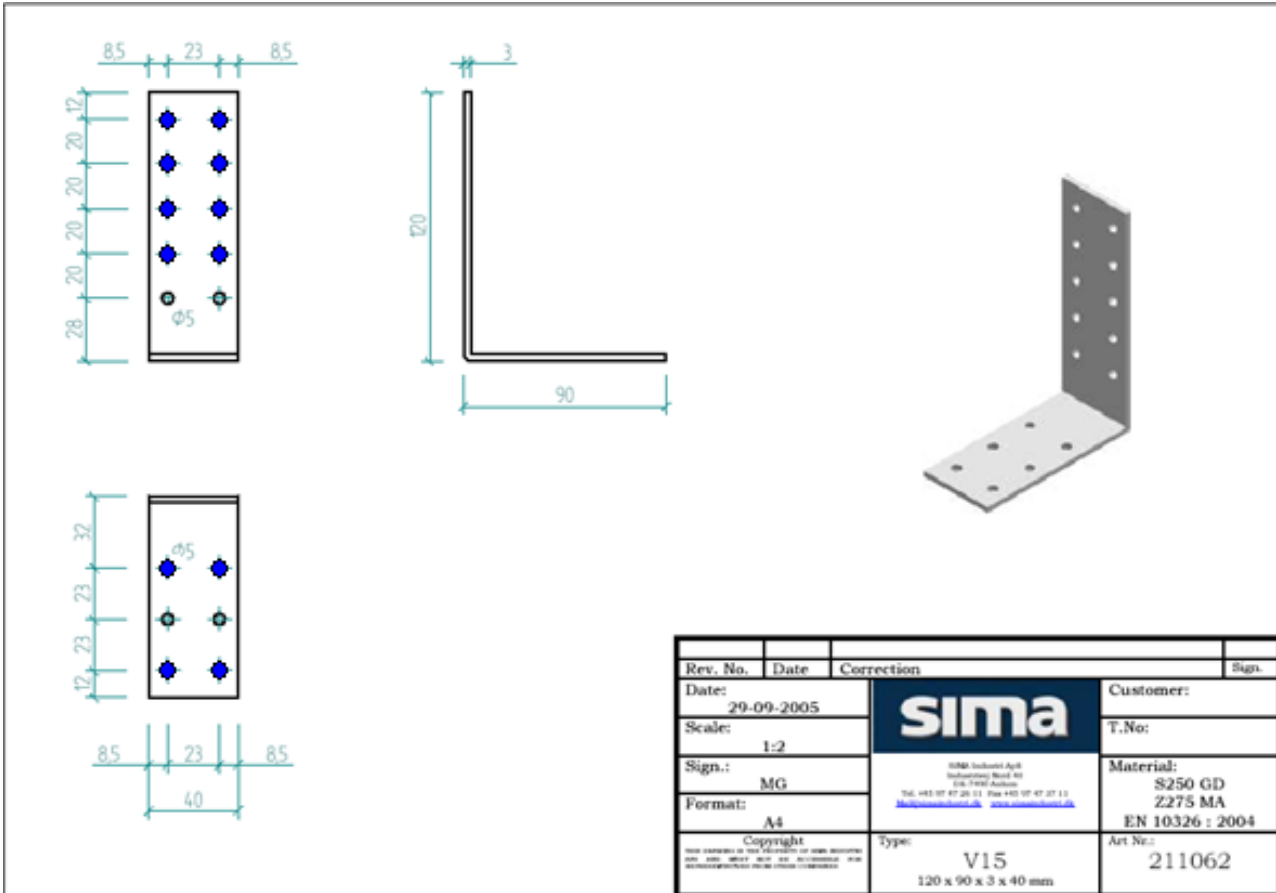

V20

Technical drawing of V20 anchor bracket. Front view shows a 40x30.5 mm plate with a 9 mm top edge, 13.5 mm top hole offset, 25 mm hole spacing, 10 mm hole offset, 20 mm hole spacing, and 20.5 mm bottom hole offset. Holes are 5.0 mm and 9.0 mm diameter. Side view shows a 2.5 mm thick plate with a 36 -1/+0 mm leg length and R2.5 fillet. Detail view shows a 7.5 mm hole offset and 10 mm hole spacing. A 3D perspective view shows the L-shaped bracket.

Coil width 120 mm

Date:	31-10-2013	sima	Tolerances:	ISO-2768m
Scale:	1:1		Weight:	89 g
Sign:	KHD	a strong connection	Material:	S250GD Z275MA
Format:	A4	<small>SIMA Industri AG Industriestrasse 46 52074Bonn Tel. +49 228 20 11 Fax +49 228 47 37 11 mailto:info@sima-industri.de www.sima-industri.de</small>	Art No.:	211067
Copyright	THIS DRAWING IS PROPERTY OF SIMA INDUSTRIALS AND MUST NOT BE ACCESSIBLE FOR REPRESENTATIVES FROM OTHER COMPANIES		Type:	V20 89 x 36 x 2,5 x 40 mm

V21

Technical drawing of V21 anchor bracket. Front view shows a 40x55 mm plate with 10, 20, 10 mm hole offsets, 28 mm hole spacing, 34 mm hole offset, 34 mm hole spacing, 24 mm hole offset, and 30 mm bottom hole offset. Holes are 5 mm diameter. Side view shows a 3 mm thick plate with a 160 mm leg length and 50 mm leg width. Detail view shows a 10, 16, 9, 17 mm hole offset and 40 mm hole spacing. A 3D perspective view shows the L-shaped bracket.

Rev. No.	Date	Correction	Sign
	29-09-2005		
Date:	29-09-2005	sima	Customer:
Scale:	1:2		T.No:
Sign.:	MG	<small>SIMA Industri AG Industriestrasse 46 52074Bonn Tel. +49 228 20 11 Fax +49 228 47 37 11 mailto:info@sima-industri.de www.sima-industri.de</small>	Material:
Format:	A4		S250 GD Z275 MA EN 10326 : 2004
Copyright	THIS DRAWING IS THE PROPERTY OF SIMA INDUSTRIALS AND MUST NOT BE ACCESSIBLE FOR REPRESENTATIVES FROM OTHER COMPANIES		Art No.:
	Type:	V21 160 x 50 x 3 x 40 mm	211068

V26

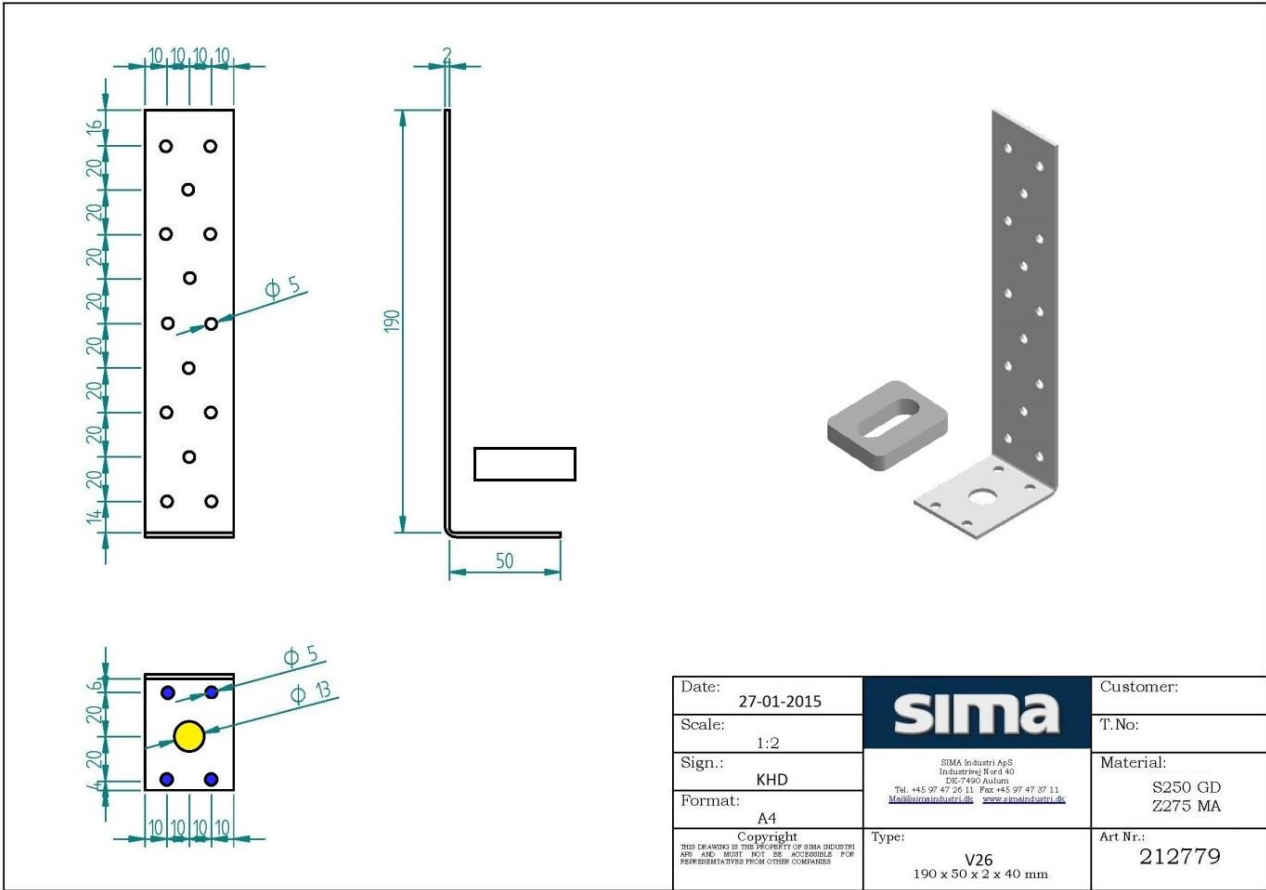

V27

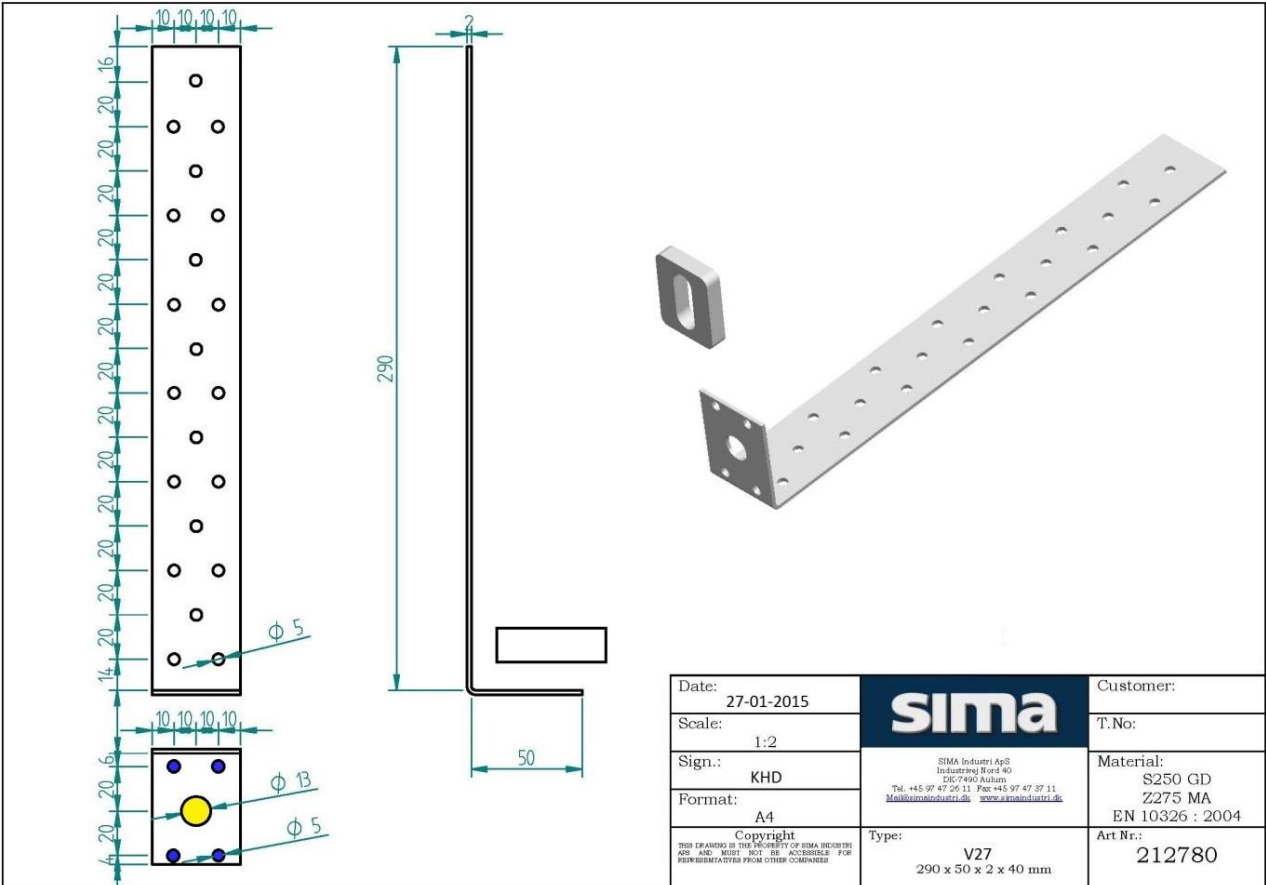

V170

Date:	27-03-2015	sima	Tolerances:	ISO-2768m
Scale:	1:2		Weight:	567 g
Sign:	KHD	a strong connection	Material:	S250GD Z275MA
Format:	A4	SIMA Industri ApS Industrivej 60 DK-7170 Aarslev Tel: +45 87 47 20 11 Fax: +45 87 47 27 11 mailto:info@sima-industri.dk www.sima-industri.dk	Art No.:	V170 - Trukket
Copyright <small>THIS DRAWING IS PROPERTY OF SIMA INDUSTRI A/S AND MUST NOT BE ACCESSIBLE FOR REPRESENTATIVES FROM OTHER COMPANIES</small>		Type:	V170 170 x 110 x 3 x 95 mm	

Coil width: 273 mm

LV1

Rev. No.	Date	Correction	Sign.
Date:	06-10-2005	sima	Customer:
Scale:	1:1		T.No:
Sign.:	MG	SIMA Industri ApS Industrivej 60 DK-7170 Aarslev Tel: +45 87 47 20 11 Fax: +45 87 47 27 11 mailto:info@sima-industri.dk www.sima-industri.dk	Material:
Format:	A4	Type:	S 250GD Z275 MA EN 10326 : 2004
Copyright <small>THIS DRAWING IS PROPERTY OF SIMA INDUSTRI A/S AND MUST NOT BE ACCESSIBLE FOR REPRESENTATIVES FROM OTHER COMPANIES</small>		Art No.:	
		LV1 82 x 62 x 2 x 40 mm m/rb	

P4

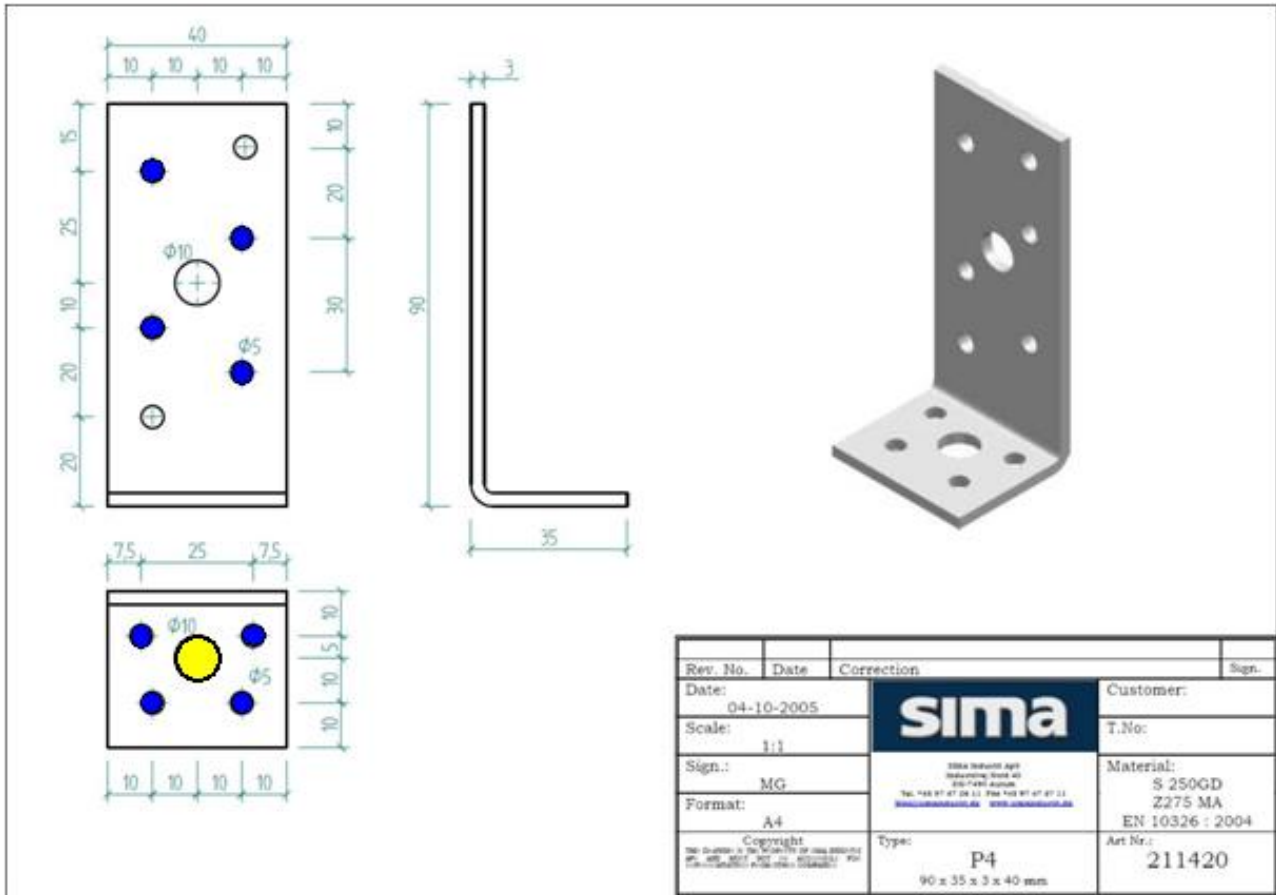

P1-8

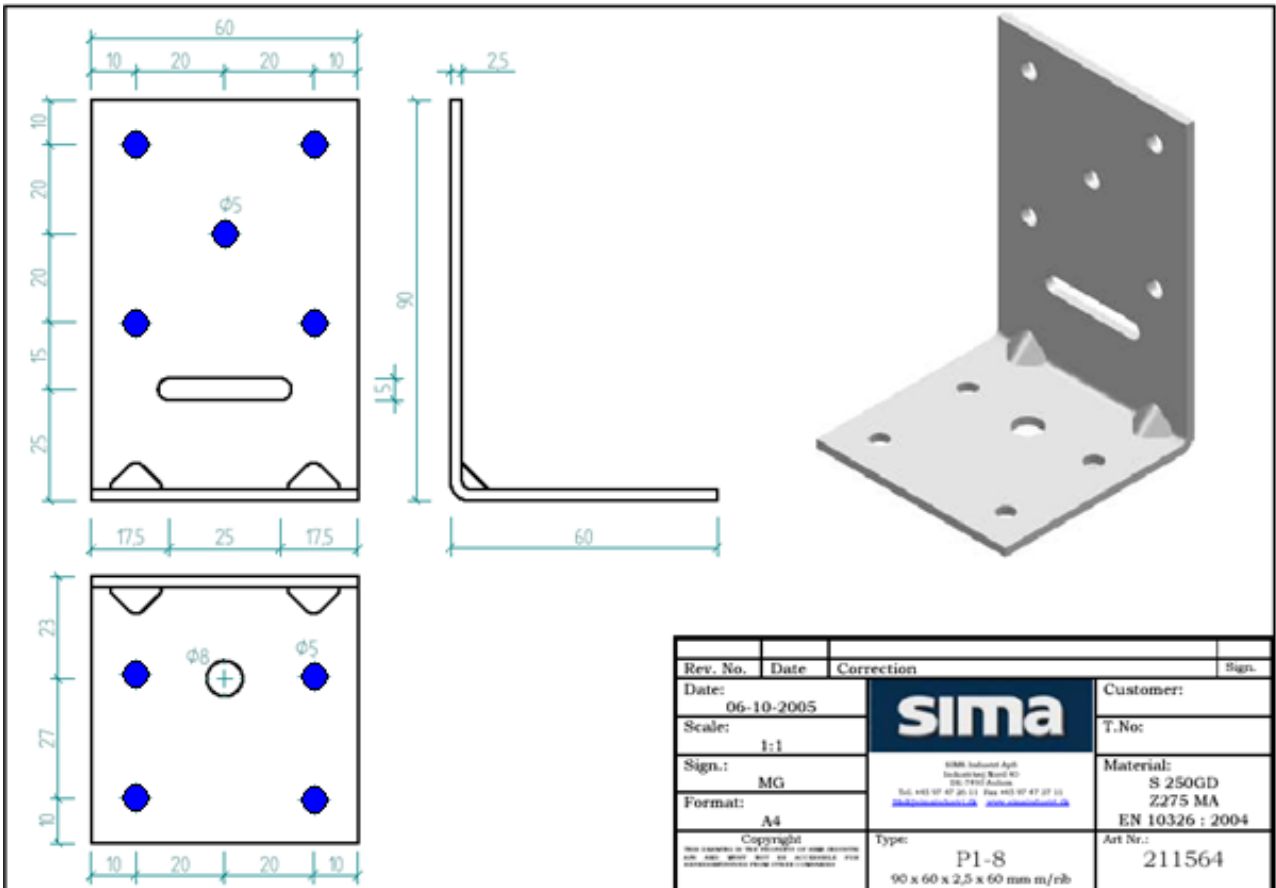

P1-10

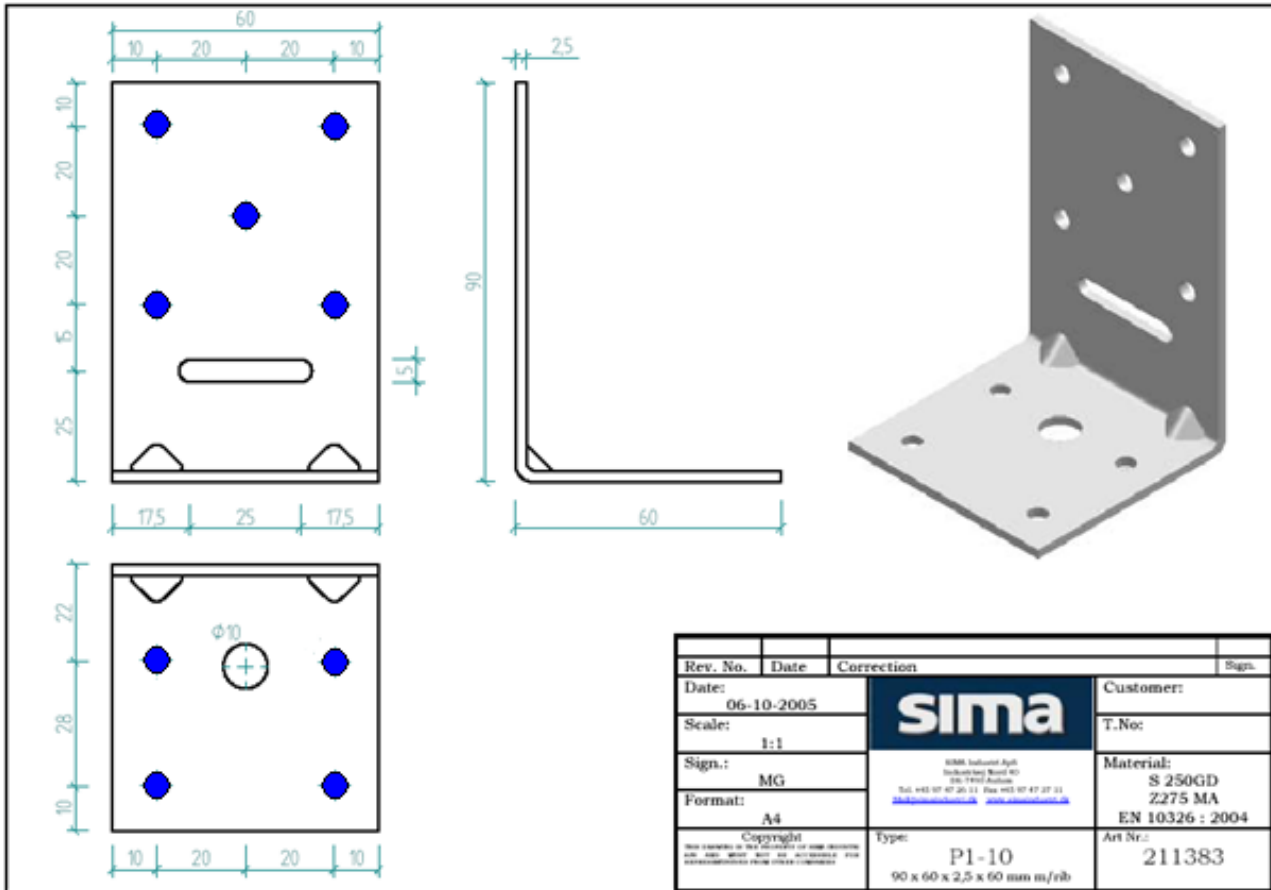

P1-12

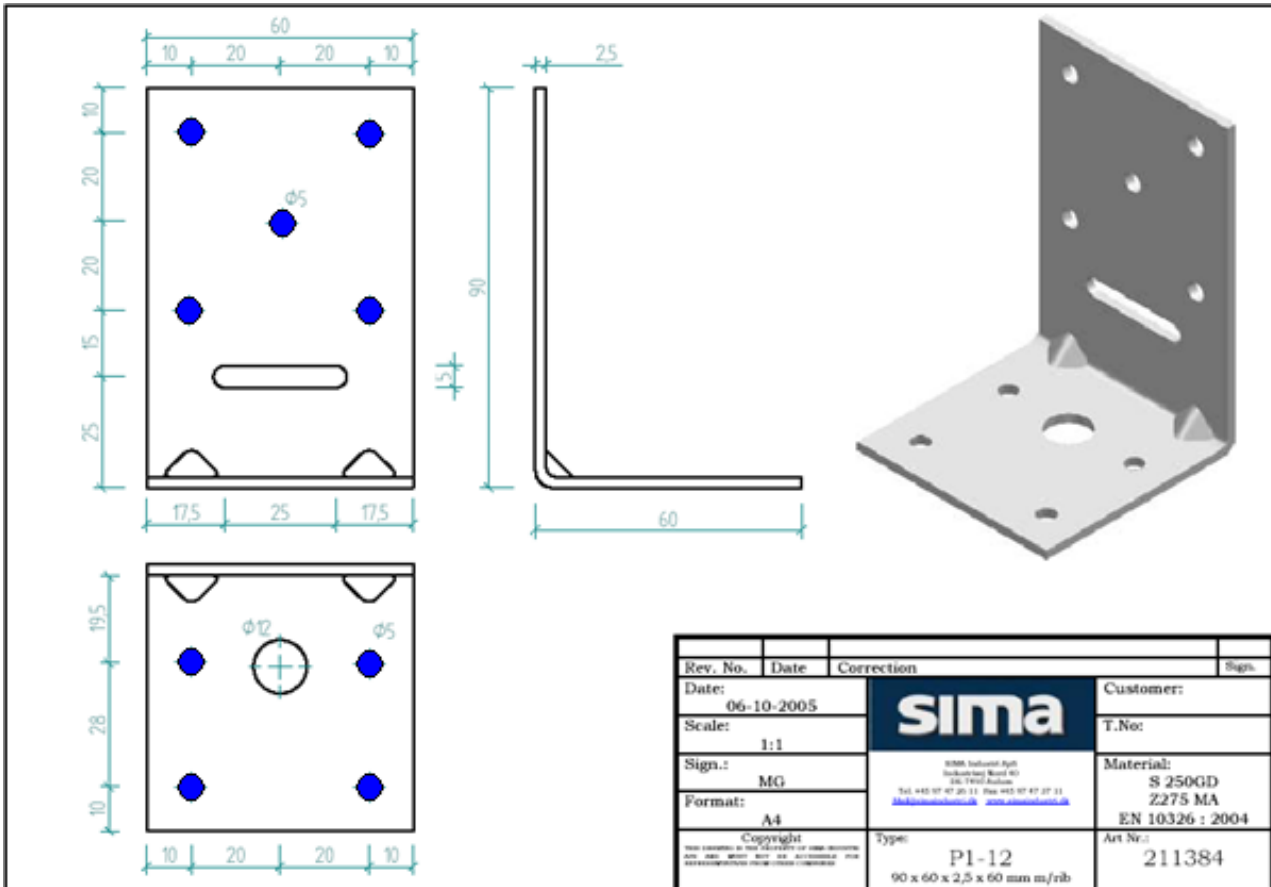

P2-10

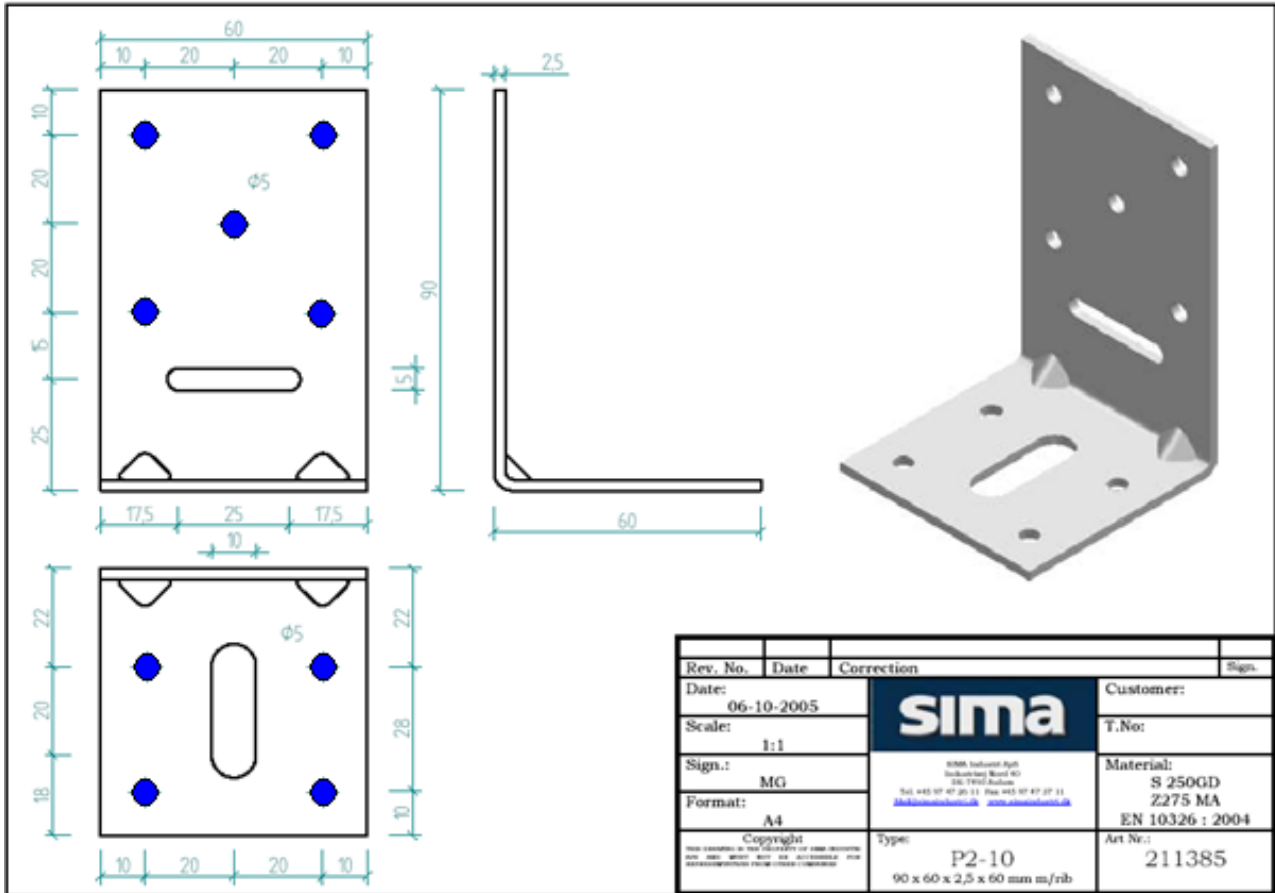

P2-12

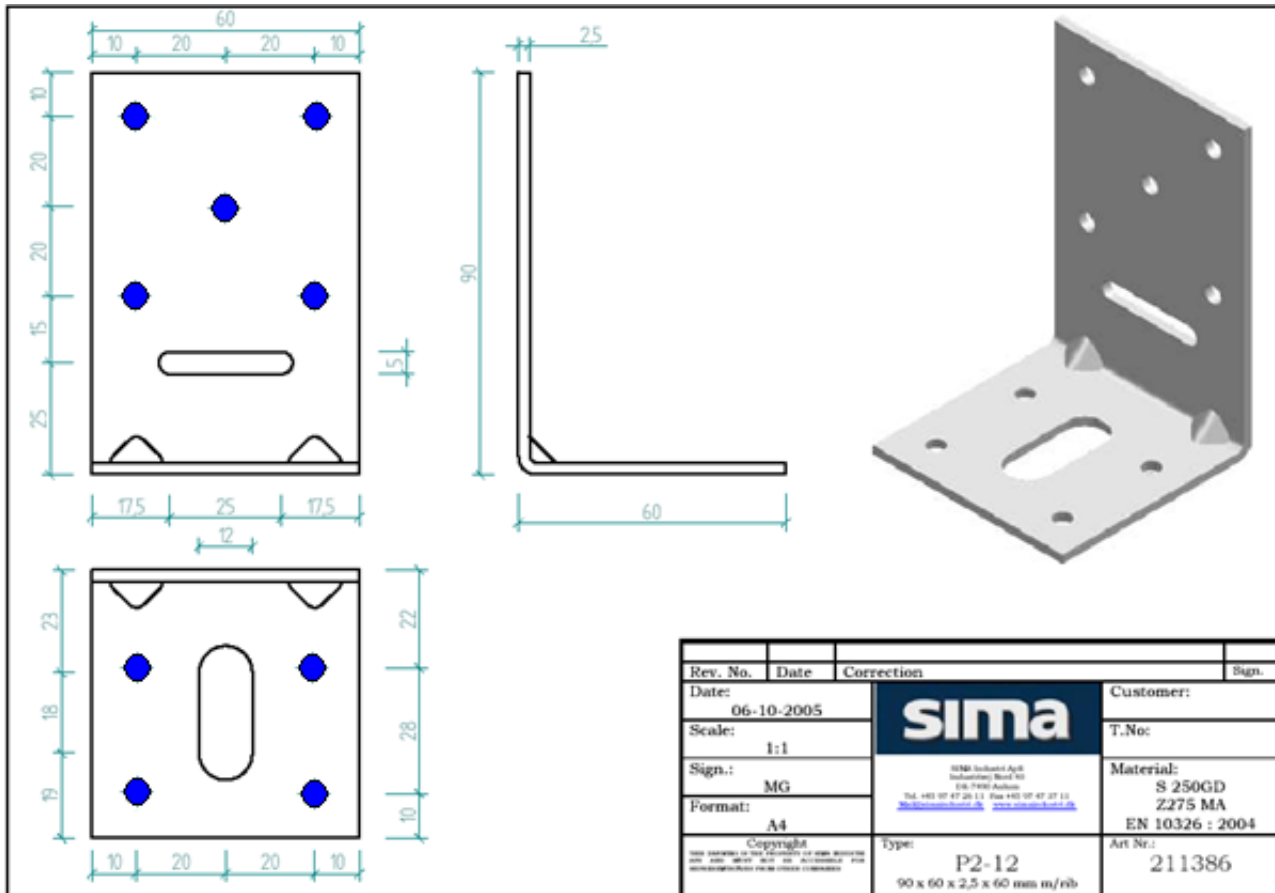

1-150

Technical drawing of part 1-150. The drawing includes a front view (top left) with a width of 60 mm (split into two 30 mm sections) and a height of 40 mm. A central hole has a diameter of $\phi 14$. A side view (top middle) shows a height of 75 mm and a width of 8 mm. A perspective view (top right) shows the L-shaped profile. A detail view (bottom left) shows a hole with a radius of $R 7$ and a height of 23 mm, with a 5 mm gap below it. The total width of the detail is 30 mm (split into two 15 mm sections).

Rev. No.	Date	Correction	Sign.
	07-10-2005		
Scale:	1:2		Customer:
Sign.:	MG		T.No.:
Format:	A4		Material:
Copyright © 2005 SIMA s.p.a. - Tutti i diritti sono riservati.		Type:	Art. Nr.:
		1-150 150 x 75 x 5 x 40 mm	S 235 JRG2 - EN 10025 DIN 1017 Hot dip galv. 211092

K4

Technical drawing of part K4. The drawing includes a front view (top left) with a total width of 80 mm (split into 10, 20, 20, 20, 10 mm sections) and a total height of 83 mm (split into 33, 20, 20, 20, 20, 20, 20 mm sections). It features a grid of 12 holes with a diameter of $\phi 5$. A side view (top middle) shows a height of 83 mm and a width of 3 mm. A perspective view (top right) shows the perforated L-shaped profile.

Rev. No.	Date	Correction	Sign.
	04-10-2005		
Scale:	1:2		Customer:
Sign.:	MG		T.No.:
Format:	A4		Material:
Copyright © 2005 SIMA s.p.a. - Tutti i diritti sono riservati.		Type:	Art. Nr.:
		K4 145 x 83 x 3 x 80 mm	S 250GD 2275 MA EN 10326 : 2004 211561

Annex C

Characteristic load-carrying capacity

Design Basis - general

Combined forces

For practical purposes the strength verification is always carried out for design forces and design capacities. If the forces are combined the following inequalities shall be fulfilled:

$$\left(\frac{F_{1,d}}{R_{1,d}}\right)^2 + \left(\frac{F_{2,d}}{R_{2,d}}\right)^2 + \left(\frac{F_{3,d}}{R_{3,d}}\right)^2 \leq 1$$

The forces $F_{2,d}$ and $F_{3,d}$ are forces with opposite direction. Only the one with a value shall be inserted while the other shall be set to zero.

$$\frac{F_{1,d}}{R_{1,d}} + \frac{F_{4,d}}{R_{4,d}} + \frac{F_{5,d}}{R_{5,d}} \leq 1$$

The forces $F_{4,d}$ and $F_{5,d}$ are forces with opposite direction. Only the one with a value shall be inserted while the other shall be set to zero.

In case of a combination where forces work in 3 directions the following formula are to be used:

$$\sqrt{\left[\frac{F_{1,d}}{R_{1,d}} + \frac{F_{4,d/5,d}}{R_{4,d/5,d}}\right]^2 + \left[\frac{F_{2,d/3,d}}{R_{2,d/3,d}}\right]^2} \leq 1$$

Timber splitting

For the lifting force F_1 it must be checked that splitting will not occur in accordance with Eurocode 5 or a similar national Timber Code.

Density

The load-carrying capacities of the angle bracket connections are stated for a characteristic density of 350 kg/m³.

For timber or wood based material with a lower characteristic density than 350 kg/m³ the load-carrying capacities shall be reduced by the k_{dens} factor:

$$k_{dens} = \left(\frac{\rho_k}{350}\right)^2$$

Where ρ_k is the characteristic density of the timber in kg/m³.

Angle Bracket V1, V1Ø7, V2, V2PL, V2 stainless, V2Ø7, V3, V4, V4PL, V4 stainless, V6, V7, V7PL, V8, V10 2,5, V10, V12, V13, V14, V15, V20, V21, V170, P4, K4, LV1, 1-150

Design Basis

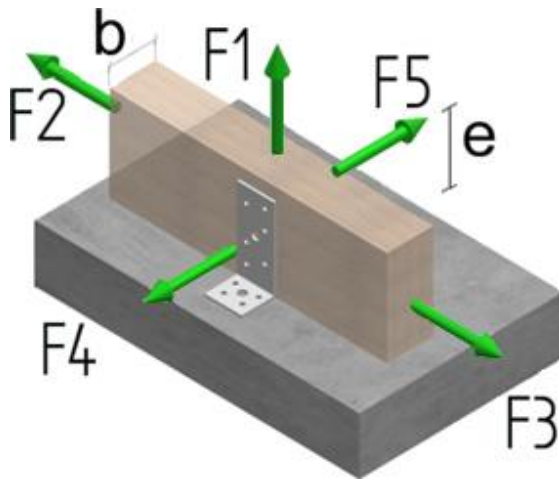

Figure 1. Forces, 1 bracket: wood to concrete

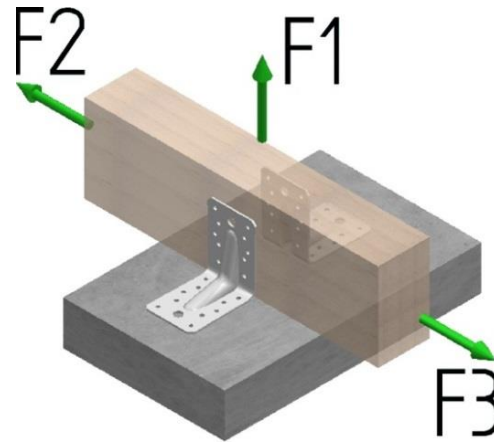

Figure 2. Forces, 2 brackets: wood to concrete

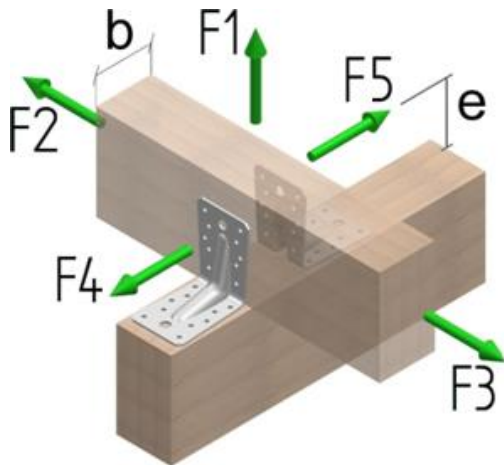

Figure 3. Forces, 2 brackets: beam to beam

Two angle brackets per connection

The angle brackets must be placed on each side of the beam opposite of each other

Acting forces

- F₁ Lifting force acting along the central axis of the joint.
- F₂ and F₃ Lateral force acting in the joint between the purlin and beam in the purlin direction.
- F₄ and F₅ Lateral force acting in the beam direction along the central axis of the joint but elevated e above the beam.

One angle bracket per connection

Acting forces

- F₄ Lateral force acting in the beam direction perpendicular to the vertical flap elevated e above the beam directed towards the angle brackets vertical flap
- F₅ Lateral force acting in the beam direction perpendicular to the vertical flap elevated e above the beam directed away from the angle brackets vertical flap

Wane

For F₁, F₂ and F₃ wane is allowed on the side towards the angle bracket with an extent from the bottom to the lower row of nails. For all other forces wane is not allowed under the angle bracket.

Note:

The characteristic values stated below for connections with 2,5 mm thick brackets type V2 made from pre-galvanized steel Grade S250GD + min. Z275 according to EN 10346 can be applied to connections made with 1,5 mm thick brackets type V2 made from pre-galvanized steel in grades from Grade S350GD to Grade S500GD + min. Z275 according to EN 10346 named V2PL.

Similarly, the characteristic values stated below for connections with 3,0 mm thick brackets type V4 made from pre-galvanized steel Grade S250GD + min. Z275 according to EN 10346 can be applied to connections made with 2,0 mm thick brackets type V4 made from pre-galvanized steel in grades from Grade S350GD to Grade S500GD + min. Z275 according to EN 10346 named V4PL.

The values have been assessed in accordance with EC 5 Table 3.1- "Values of K_{mod} " where needed.

1 angle bracket V1, wood to concrete

Paslode Connector nails 4,0 × 40 mm / Expansion bolt	No. of fasteners pr connection	Load Duration	F4, [kN]	F5, [kN]
12,13,14,15,16	5 nails	P	25,4/e, max ↓ 20,63	1,85*(2,5+b)/e, max ↓ 1,07
		L	25,4/e, max ↓ 20,63	2,16*(2,5+b)/e, max ↓ 1,25
		M	25,4/e, max ↓ 20,63	2,47*(2,5+b)/e, max ↓ 1,42
Holes marked yellow	3 bolts	S	25,4/e, max ↓ 20,63	2,78*(2,5+b)/e, max ↓ 1,60
		I	25,4/e, max ↓ 20,63	3,40*(2,5+b)/e, max ↓ 1,96
Characteristic values, b and e in mm			25,4/e, max ↓ 20,63	3,09*(2,5+b)/e, max ↓ 1,78

2 angle brackets V1, wood to concrete

Paslode Connector nails 4,0 × 40 mm / Expansion bolt	No. of fasteners pr connection	Load Duration	F1, [kN]	F2 /F3, [kN]
12,13,14,15,16	10 nails	P	2,45	19,24
		L	2,86	22,44
		M	3,26	25,65
Holes marked yellow	6 bolts	S	3,67	28,85
		I	4,49	35,27
Characteristic values			4,08	32,06

2 angle brackets V1, beam to beam connection

Paslode Connector nails 4,0 × 40 mm	No. of nails pr connection	Load Duration	F1, [kN]	F2 /F3, [kN]	F4 /F5, [kN]
1,2,3,4	16	P	2,03	4,40	$0,47 \cdot (29,6+b)/e$, max ↓ 5,36
		L	2,37	5,13	$0,55 \cdot (29,6+b)/e$, max ↓ 6,25
M		2,71	5,86	$0,62 \cdot (29,6+b)/e$, max ↓ 7,14	
S		3,05	6,60	$0,70 \cdot (29,6+b)/e$, max ↓ 8,04	
I		3,73	8,06	$0,86 \cdot (29,6+b)/e$, max ↓ 9,82	
8,11,15,16					
Characteristic values, b and e in mm			3,38	7,33	$0,78 \cdot (29,6+b)/e$, max ↓ 8,93

Paslode Connector nails 4,0 × 40 mm	No. of nails pr connection	Load Duration	F1, [kN]	F2 /F3, [kN]	F4 /F5, [kN]
1,2,3,4	20	P	4,07	4,40	$0,47 \cdot (29,6+b)/e$, max ↓ 8,04
		L	4,75	5,13	$0,55 \cdot (29,6+b)/e$, max ↓ 9,38
M		5,42	5,86	$0,62 \cdot (29,6+b)/e$, max ↓ 10,72	
S		6,10	6,60	$0,70 \cdot (29,6+b)/e$, max ↓ 12,06	
I		7,46	8,06	$0,86 \cdot (29,6+b)/e$, max ↓ 14,74	
8,9,10,11,15,16					
Characteristic values, b and e in mm			6,78	7,33	$0,78 \cdot (29,6+b)/e$, max ↓ 13,40

Paslode Connector nails 4,0 × 40 mm	No. of nails pr connection	Load Duration	F1, [kN]	F2 /F3, [kN]	F4 /F5, [kN]
1,2,3,4,5,6	30	P	4,07	6,31	$0,47 \cdot (29,6+b)e$, max ↓ 12,05
		L	4,75	7,36	$0,55 \cdot (29,6+b)/e$, max ↓ 14,06
M		5,42	8,41	$0,62 \cdot (29,6+b)/e$, max ↓ 16,07	
S		6,10	9,46	$0,70 \cdot (29,6+b)/e$, max ↓ 18,08	
I		7,46	11,56	$0,86 \cdot (29,6+b)/e$, max ↓ 22,10	
8,9,10,11,12,13,14,15,16					
Characteristic values, b and e in mm			6,78	10,52	$0,78 \cdot (29,6+b)/e$, max ↓ 20,08

Paslode Connector nails 4,0 × 60 mm	No. of nails pr connection	Load Duration	F1, [kN]	F2 /F3, [kN]	F4 /F5, [kN]
1,2,3,4 8,11,15,16	16	P	3,78	4,40	$0,87 \cdot (15,9+b)/e$, max ↓ 5,36
		L	4,41	5,13	$1,02 \cdot (15,9+b)/e$, max ↓ 6,25
		M	5,04	5,86	$1,16 \cdot (15,9+b)/e$, max ↓ 7,14
		S	5,67	6,60	$1,31 \cdot (15,9+b)/e$, max ↓ 8,04
		I	6,93	8,06	$1,60 \cdot (15,9+b)/e$, max ↓ 9,82
Characteristic values, b and e in mm			6,30	7,33	$1,45 \cdot (15,9+b)/e$, max ↓ 8,93

Paslode Connector nails 4,0 × 60 mm	No. of nails pr connection	Load Duration	F1, [kN]	F2 /F3, [kN]	F4 /F5, [kN]
1,2,3,4 8,9,10,11,15,16	20	P	5,01	4,40	$0,87 \cdot (15,9+b)/e$, max ↓ 8,04
		L	5,85	5,13	$1,02 \cdot (15,9+b)/e$, max ↓ 9,38
		M	6,68	5,86	$1,16 \cdot (15,9+b)/e$, max ↓ 10,72
		S	7,52	6,60	$1,31 \cdot (15,9+b)/e$, max ↓ 12,06
		I	9,19	8,06	$1,60 \cdot (15,9+b)/e$, max ↓ 14,74
Characteristic values, b and e in mm			8,36	7,33	$1,45 \cdot (15,9+b)/e$, max ↓ 13,40

Paslode Connector nails 4,0 × 60 mm	No. of nails pr connection	Load Duration	F1, [kN]	F2 /F3, [kN]	F4 /F5, [kN]
1,2,3,4,5,6 8,9,10,11,12,13,14,15,16	30	P	6,78	6,31	$0,87 \cdot (15,9+b)/e$, max ↓ 12,05
		L	7,91	7,36	$1,02 \cdot (15,9+b)/e$, max ↓ 14,06
		M	9,04	8,41	$1,16 \cdot (15,9+b)/e$, max ↓ 16,06
		S	10,17	9,46	$1,31 \cdot (15,9+b)/e$, max ↓ 18,08
		I	12,43	11,56	$1,60 \cdot (15,9+b)/e$, max ↓ 22,10
Characteristic values, b and e in mm			11,30	10,51	$1,45 \cdot (15,9+b)/e$, max ↓ 20,09

2 angle brackets V1Ø7

M6 Hexagon wood screw	No. of screws pr connection	Load Duration	F1, [kN]	F2 /F3, [kN]	F4 /F5, [kN]
Holes marked yellow	4 bolts	P	1,87	0,49	$0,93*(2,5+b)/e$, max ↓ 1,87
		L	2,18	0,57	$1,09*(2,5+b)/e$, max ↓ 2,18
		M	2,49	0,66	$1,24*(2,5+b)/e$, max ↓ 2,49
	8 bolts	S	2,80	0,74	$1,40*(2,5+b)/e$, max ↓ 2,80
		I	3,42	0,90	$1,71*(2,5+b)/e$, max ↓ 3,42
Characteristic values, b and e in mm			3,11	0,81	$1,55*(2,5+b)/e$, max ↓ 3,11

1 angle bracket V2 and V2PL, wood to concrete

Paslode Connector nails 4,0 × 40 mm / Expansion bolt	No. of fasteners pr connection	Load Duration	F4, [kN]	F5, [kN]
2,3,4,5,6,7,8,9	8 nails	P	$25,4/e$, max ↓ 20,63	$1,53*(2,5+b)/e$, max ↓ 1,22
		L	$25,4/e$, max ↓ 20,63	$1,74*(2,5+b)/e$, max ↓ 1,42
		M	$25,4/e$, max ↓ 20,63	$2,04*(2,5+b)/e$, max ↓ 1,62
Hole marked yellow	1 bolt	S	$25,4/e$, max ↓ 20,63	$2,30*(2,5+b)/e$, max ↓ 1,83
		I	$25,4/e$, max ↓ 20,63	$2,81*(2,5+b)/e$, max ↓ 2,23
Characteristic values, b and e in mm			$25,4/e$, max ↓ 20,63	$2,55*(2,5+b)/e$, max ↓ 2,03

1 angle bracket V2 and V2PL, beam to beam connection

Paslode Connector nails 4,0 × 60 mm	No. of nails pr connection	Load Duration	F1, [kN]	F2 /F3, [kN]	F4, [kN]	F5, [kN]
2,3,4,5,6,7,8,9	18	P	1,75	2,87	$25,4/e$, max ↓ 6,41	$6,41*(37,5+b)/e$, max ↓ 1,75
		L	2,04	3,35	$25,4/e$, max ↓ 7,48	$7,48*(37,5+b)/e$, max ↓ 2,04
		M	2,34	3,82	$25,4/e$, max ↓ 8,55	$8,55*(37,5+b)/e$, max ↓ 2,34
11,12,13,14,15,16, 17,18,19,20		S	2,63	4,30	$25,4/e$, max ↓ 9,62	$9,62*(37,5+b)/e$, max ↓ 2,63
		I	3,21	5,26	$25,4/e$, max ↓ 11,76	$11,76*(37,5+b)/e$, max ↓ 3,21
Characteristic values, b and e in mm			2,91	4,78	$25,4/e$, max ↓ 10,68	$10,69*(37,5+b)/e$, max ↓ 2,92

2 angle brackets V2 and V2PL, wood to concrete

Paslode Connector nails 4,0 × 40 mm / Expansion bolt	No. of fasteners pr connection	Load Duration	F1, [kN]	F2 /F3, [kN]
2,3,4,5,6,7,8,9	16 nails	P	0,76	5,17
		L	0,89	6,03
		M	1,02	6,90
		S	1,14	7,76
Holes marked yellow	2 bolts	I	1,40	9,48
Characteristic values			1,27	8,62

2 angle brackets V2 and V2PL, beam to beam connection

Paslode Connector nails 4,0 × 40 mm	No. of nails pr connection	Load Duration	F1, [kN]	F2 /F3, [kN]	F4 /F5, [kN]
2,3,4,5,6,7,8,9	36	P	5,58	8,70	$2,10^*(41,1+b)/e$, max ↓ 9,42
		L	6,51	10,15	$2,45^*(41,1+b)/e$, max ↓ 10,99
		M	7,44	11,60	$2,80^*(41,1+b)/e$, max ↓ 12,56
		S	8,37	13,05	$3,15^*(41,1+b)/e$, max ↓ 14,13
11,12,13,14,15,16, 17,18,19,20		I	10,23	15,95	$3,85^*(41,1+b)/e$, max ↓ 17,27
Characteristic values, b and e in mm			9,30	14,50	$3,50^*(41,1+b)/e$, max ↓ 15,70

Paslode Connector nails 4,0 × 60 mm	No. of nails pr connection	Load Duration	F1, [kN]	F2 /F3, [kN]	F4 /F5, [kN]
2,5,6,9	16	P	4,07	4,33	$0,94^*(65+b)/e$, max ↓ 5,36
		L	4,75	5,05	$1,09^*(65+b)/e$, max ↓ 6,25
		M	5,42	5,78	$1,25^*(65+b)/e$, max ↓ 7,14
		S	6,10	6,50	$1,40^*(65+b)/e$, max ↓ 8,04
11,15,16,20		I	7,46	7,94	$1,72^*(65+b)/e$, max ↓ 9,82
Characteristic values, b and e in mm			6,78	7,22	$1,56^*(65+b)/e$, max ↓ 8,93

Paslode Connector nails 4,0 x 60 mm	No. of nails pr connection	Load Duration	F1, [kN]	F2 /F3, [kN]	F4 /F5, [kN]
2,3,4,5,6,7,8,9 11,12,13,15,16, 17,18,20	32	P	7,33	7,98	$1,69 \cdot (47,5+b)/e$, max ↓ 10,72
		L	8,55	9,31	$1,97 \cdot (47,5+b)/e$, max ↓ 12,50
		M	9,78	10,64	$2,25 \cdot (47,5+b)/e$, max ↓ 14,29
		S	11,00	11,97	$2,53 \cdot (47,5+b)/e$, max ↓ 16,07
		I	13,44	14,63	$3,09 \cdot (47,5+b)/e$, max ↓ 19,65
Characteristic values, b and e in mm			12,22	13,30	$2,81 \cdot (47,5+b)/e$, max ↓ 17,86

Paslode Connector nails 4,0 x 60 mm	No. of nails pr connection	Load Duration	F1, [kN]	F2 /F3, [kN]	F4 /F5, [kN]
2,3,4,5,6,7,8,9 11,12,13,14,15,16, 17,18,19,20	36	P	9,66	8,52	$2,1 \cdot (41,1+b)/e$, max ↓ 9,06
		L	11,27	9,94	$2,45 \cdot (41,1+b)/e$, max ↓ 10,5
		M	12,88	11,36	$2,8 \cdot (41,1+b)/e$, max ↓ 12,08
		S	14,49	12,78	$3,15 \cdot (41,1+b)/e$, max ↓ 13,59
		I	17,71	15,62	$3,85 \cdot (41,1+b)/e$, max ↓ 16,61
Characteristic values, b and e in mm			16,10	14,20	$3,50 \cdot (41,1+b)/e$, max ↓ 15,10

2 angle brackets V2 Stainless, beam to beam connection

Paslode Connector nails 4,0 x 40 mm	No. of nails pr connection	Load Duration	F1, [kN]	F2 /F3, [kN]	F4 /F5, [kN]
Holes marked blue	36	P	4,79	6,91	$2,4 \cdot (22+b)/e$, max ↓ 7,73
		L	5,59	8,06	$2,8 \cdot (22+b)/e$, max ↓ 9,02
		M	6,38	9,22	$3,2 \cdot (22+b)/e$, max ↓ 10,31
		S	7,18	10,37	$3,6 \cdot (22+b)/e$, max ↓ 11,60
		I	8,78	12,67	$4,4 \cdot (22+b)/e$, max ↓ 14,18
Characteristic values, b and e in mm			7,98	11,52	$4,0 \cdot (22+b)/e$, max ↓ 12,89

2 angle brackets V2Ø7

M6 Hexagon wood screw	No. of screws pr connection	Load Duration	F1, [kN]	F2 /F3, [kN]	F4 /F5, [kN]
Holes marked yellow	8 bolts	P	1,87	1,51	$0,93 \cdot (15,9+b)/e$, max ↓ 1,87
		L	2,18	1,76	$1,09 \cdot (15,9+b)/e$, max ↓ 2,18
		M	2,49	2,02	$1,24 \cdot (15,9+b)/e$, max ↓ 2,49
	8 bolts	S	2,80	2,27	$1,40 \cdot (15,9+b)/e$, max ↓ 2,80
		I	3,42	2,77	$1,71 \cdot (15,9+b)/e$, max ↓ 3,42
Characteristic values, b and e in mm			3,11	2,52	$1,55 \cdot (15,9+b)/e$, max ↓ 3,11

1 angle bracket V3, wood to concrete

Paslode Connector nails 4,0 × 40 mm / Expansion bolt	No. of fasteners pr connection	Load Duration	F4, [kN]	F5, [kN]
Holes marked yellow	8 nails	P	$50,6/e$, max ↓ 54,75	$3,63 \cdot (3+b)/e$, max ↓ 1,04
		L	$50,6/e$, max ↓ 54,75	$4,24 \cdot (3+b)/e$, max ↓ 1,22
		M	$50,6/e$, max ↓ 54,75	$4,84 \cdot (3+b)/e$, max ↓ 1,39
	3 bolts	S	$50,6/e$, max ↓ 54,75	$5,45 \cdot (3+b)/e$, max ↓ 1,57
		I	$50,6/e$, max ↓ 54,75	$6,65 \cdot (3+b)/e$, max ↓ 1,91
Characteristic values, b and e in mm			$50,6/e$, max ↓ 54,75	$6,05 \cdot (3+b)/e$, max ↓ 1,74

2 angle brackets V3, wood to concrete

Paslode Connector nails 4,0 × 40 mm / Expansion bolt	No. of fasteners pr connection	Load Duration	F1, [kN]	F2 /F3, [kN]	F4 /F5, [kN]
Holes marked yellow	16 nails	P	9,61	5,49	$30,36/e$, max ↓ 54,75
		L	9,61	6,41	$35,42/e$, max ↓ 54,75
		M	9,61	7,32	$40,48/e$, max ↓ 54,75
	6 bolts	S	9,61	8,24	$45,54/e$, max ↓ 54,75
		I	9,61	10,07	$55,66/e$, max ↓ 54,75
Characteristic values, b and e in mm			9,61	9,15	$50,60/e$, max ↓ 54,75

2 angle brackets V3, beam to beam connection

Paslode Connector nails 4,0 × 40 mm	No. of nails pr connection	Load Duration	F1, [kN]	F2 /F3, [kN]	F4 /F5, [kN]
1,2,8,9 11,16,23,24	16	P	2,08	4,97	$0,48 \cdot (57,8+b)/e$, max ↓ 5,36
		L	2,42	5,80	$0,56 \cdot (57,8+b)/e$, max ↓ 6,25
		M	2,77	6,62	$0,64 \cdot (57,8+b)/e$, max ↓ 7,14
		S	3,11	7,45	$0,72 \cdot (57,8+b)/e$, max ↓ 8,04
		I	3,81	9,11	$0,88 \cdot (57,8+b)/e$, max ↓ 9,82
Characteristic values, b and e in mm			3,46	8,28	$0,80 \cdot (57,8+b)/e$, max ↓ 8,93

Paslode Connector nails 4,0 × 40 mm	No. of nails pr connection	Load Duration	F1, [kN]	F2 /F3, [kN]	F4 /F5, [kN]
1,2,5,6,8,9 11,12,15,16,23,24	24	P	4,15	7,03	$0,95 \cdot (28,9+b)/e$, max ↓ 8,04
		L	4,84	8,20	$1,11 \cdot (28,9+b)/e$, max ↓ 9,38
		M	5,53	9,38	$1,27 \cdot (28,9+b)/e$, max ↓ 10,72
		S	6,22	10,55	$1,43 \cdot (28,9+b)/e$, max ↓ 12,06
		I	7,60	12,89	$1,75 \cdot (28,9+b)/e$, max ↓ 14,74
Characteristic values, b and e in mm			6,91	11,72	$1,59 \cdot (28,9+b)/e$, max ↓ 13,40

Paslode Connector nails 4,0 × 40 mm	No. of nails pr connection	Load Duration	F1, [kN]	F2 /F3, [kN]	F4 /F5, [kN]
1,2,3,4,5,6 11,12,13,14,15,16,23,24	28	P	6,22	5,53	$1,43 \cdot (19,3+b)/e$, max ↓ 10,72
		L	7,25	6,45	$1,67 \cdot (19,3+b)/e$, max ↓ 12,50
		M	8,29	7,37	$1,91 \cdot (19,3+b)/e$, max ↓ 14,29
		S	9,32	8,29	$2,15 \cdot (19,3+b)/e$, max ↓ 16,07
		I	11,40	10,13	$2,63 \cdot (19,3+b)/e$, max ↓ 19,65
Characteristic values, b and e in mm			10,36	9,21	$2,39 \cdot (19,3+b)/e$, max ↓ 17,86

Paslode Connector nails 4,0 × 40 mm	No. of nails pr connection	Load Duration	F1, [kN]	F2 /F3, [kN]	F4 /F5, [kN]
1,2,3,4,5,6 11,12,13,14,15, 16,21,22,23,24	38	P	6,22	10,38	$1,43 \cdot (19,3+b)/e$, max ↓ 13,40
		L	7,25	12,11	$1,67 \cdot (19,3+b)/e$, max ↓ 15,63
		M	8,29	13,84	$1,91 \cdot (19,3+b)/e$, max ↓ 17,86
		S	9,32	15,57	$2,15 \cdot (19,3+b)/e$, max ↓ 20,10
		I	11,40	19,03	$2,63 \cdot (19,3+b)/e$, max ↓ 24,56
Characteristic values, b and e in mm			10,36	17,30	$2,39 \cdot (19,3+b)/e$, max ↓ 22,33

Paslode Connector nails 4,0 × 60 mm	No. of nails pr connection	Load Duration	F1, [kN]	F2 /F3, [kN]	F4 /F5, [kN]
1,2,8,9 11,16,23,24	16	P	3,85	4,97	$0,89 \cdot (31,2+b)/e$, max ↓ 5,36
		L	4,49	5,80	$1,03 \cdot (31,2+b)/e$, max ↓ 6,25
		M	5,13	6,62	$1,18 \cdot (31,2+b)/e$, max ↓ 7,14
		S	5,77	7,45	$1,33 \cdot (31,2+b)/e$, max ↓ 8,04
		I	7,05	9,11	$1,63 \cdot (31,2+b)/e$, max ↓ 9,82
Characteristic values, b and e in mm			6,41	8,28	$1,48 \cdot (31,2+b)/e$, max ↓ 8,93

Paslode Connector nails 4,0 × 60 mm	No. of nails pr connection	Load Duration	F1, [kN]	F2 /F3, [kN]	F4 /F5, [kN]
1,2,5,6,8,9 11,12,15,16,23,24	24	P	7,70	7,03	$1,77 \cdot (15,6+b)/e$, max ↓ 8,04
		L	8,98	8,20	$2,06 \cdot (15,6+b)/e$, max ↓ 9,38
		M	10,26	9,38	$2,36 \cdot (15,6+b)/e$, max ↓ 10,72
		S	11,55	10,55	$2,65 \cdot (15,6+b)/e$, max ↓ 12,06
		I	14,11	12,89	$3,42 \cdot (15,6+b)/e$, max ↓ 14,74
Characteristic values, b and e in mm			12,83	11,72	$2,95 \cdot (15,6+b)/e$, max ↓ 13,40

Paslode Connector nails 4,0 × 60 mm	No. of nails pr connection	Load Duration	F1, [kN]	F2 /F3, [kN]	F4 /F5, [kN]
1,2,3,4,5,6 11,12,13,14,15,16,23,24	28	P	10,02	5,53	2,30*(12+b)/e, max ↓ 10,72
		L	11,69	6,45	2,70*(12+b)/e, max ↓ 12,50
		M	13,36	7,37	3,07*(12+b)/e, max ↓ 14,29
		S	15,03	8,29	3,45*(12+b)/e, max ↓ 16,07
		I	18,37	10,13	4,22*(12+b)/e, max ↓ 19,65
Characteristic values, b and e in mm			16,70	9,22	3,84*(12+b)/e, max ↓ 17,87

1 angle bracket V4 and V4PL, wood to concrete

Paslode Connector nails 4,0 × 40 mm / Expansion bolt	No. of fasteners pr connection	Load Duration	F4, [kN]	F5, [kN]
Vertical flap fully nailed	14 nails	P	50,6/e, max ↓ 54,75	3,89*(3+b)/e, max ↓ 1,52
		L	50,6/e, max ↓ 54,75	4,54*(3+b)/e, max ↓ 1,77
		M	50,6/e, max ↓ 54,75	5,19*(3+b)/e, max ↓ 2,02
Holes marked yellow	3 bolts	S	50,6/e, max ↓ 54,75	5,84*(3+b)/e, max ↓ 2,28
		I	50,6/e, max ↓ 54,75	7,14*(3+b)/e, max ↓ 2,78
Characteristic values, b and e in mm			50,6/e, max ↓ 54,75	6,49*(3+b)/e, max ↓ 2,53

1 angle bracket V4 and V4PL, beam to beam connection

Paslode Connector nails 4,0 × 40 mm	No. of nails pr connection	Load Duration	F1, [kN]	F2 /F3, [kN]	F4, [kN]	F5, [kN]
Fully nailed	22	P	1,75	2,83	47,8/e, max ↓ 8,55	8,55*(33+b)/e, max ↓ 0,88
		L	2,04	3,30	47,8/e, max ↓ 8,55	9,98*(33+b)/e, max ↓ 1,02
		M	2,34	3,77	47,8/e, max ↓ 8,55	11,40*(33+b)/e, max ↓ 1,17
		S	2,63	4,24	47,8/e, max ↓ 8,55	12,83*(33+b)/e, max ↓ 1,31
		I	3,21	5,18	47,8/e, max ↓ 8,55	15,68*(33+b)/e, max ↓ 1,61
Characteristic values, b and e in mm			2,92	4,72	47,8/e, max ↓ 8,55	14,25*(33+b)/e, max ↓ 1,46

2 angle brackets V4 and V4PL, wood to concrete

Paslode Connector nails 4,0 × 40 mm / Expansion bolt	No. of fasteners pr connection	Load Duration	F1, [kN]	F2 /F3, [kN]
Vertical flap fully nailed	28 nails	P	5,29	29,93
		L	6,17	34,92
		M	7,06	39,90
Holes marked yellow	6 bolts	S	7,94	44,89
		I	9,70	54,87
Characteristic values			8,82	49,88

2 angle brackets V4 and V4PL, beam to beam connection

Paslode Connector nails 4,0 × 40 mm	No. of nails pr connection	Load Duration	F2 /F3, [kN]
1,3,4,5,6,8	24	P	7,48
		L	8,73
		M	9,98
S		11,22	
9,10,15,16,17,22		I	13,72
Characteristic values			12,47

Paslode Connector nails 4,0 × 40 mm	No. of nails pr connection	Load Duration	F1, [kN]	F2 /F3, [kN]	F4 /F5, [kN]
1,2,3,4,5,6,7,8	32	P	9,9	9,68	$2,62 \cdot (56,3+b)/e$, max ↓ 9,06
		L	11,55	11,30	$3,09 \cdot (56,3+b)/e$, max ↓ 10,57
		M	13,20	12,91	$3,54 \cdot (56,3+b)/e$, max ↓ 12,08
		S	14,85	14,53	$3,98 \cdot (56,3+b)/e$, max ↓ 13,59
		9,10,11,15,16,17,18,22	I	18,15	17,75
Characteristic values, b and e in mm			16,50	16,14	$4,42 \cdot (56,3+b)/e$, max ↓ 15,10

Paslode Connector nails 4,0 × 60 mm	No. of nails pr connection	Load Duration	F1, [kN]	F2 /F3, [kN]	F4 /F5, [kN]
1,2,3,4,5,6,7,8	24	P	8,14	7,48	$1,87 \cdot (73,5+b)/e$, max ↓ 8,04
		L	9,50	8,73	$2,18 \cdot (73,5+b)/e$, max ↓ 9,38
		M	10,86	9,98	$2,50 \cdot (73,5+b)/e$, max ↓ 10,72
		S	12,21	11,22	$2,81 \cdot (73,5+b)/e$, max ↓ 12,06
		I	14,93	13,72	$3,43 \cdot (73,5+b)/e$, max ↓ 14,74
9,10,15,16,17,22					
Characteristic values, b and e in mm			13,57	12,47	$3,12 \cdot (73,5+b)/e$, max ↓ 13,40

Paslode Connector nails 4,0 × 60 mm	No. of nails pr connection	Load Duration	F1, [kN]	F2 /F3, [kN]	F4 /F5, [kN]
1,2,3,4,5,6,7,8	32	P	13,32	9,84	$2,62 \cdot (56,3+b)/e$, max ↓ 10,26
		L	15,54	11,48	$3,09 \cdot (56,3+b)/e$, max ↓ 11,97
		M	17,76	13,12	$3,54 \cdot (56,3+b)/e$, max ↓ 13,68
		S	19,98	14,76	$3,98 \cdot (56,3+b)/e$, max ↓ 15,39
		I	24,42	18,04	$4,86 \cdot (56,3+b)/e$, max ↓ 18,81
9,10,11,15,16,17,18,22					
Characteristic values, b and e in mm			22,20	16,40	$4,42 \cdot (56,3+b)/e$, max ↓ 17,10

2 angle brackets V4 Stainless, beam to beam connection

Paslode Connector nails 4,0 × 40 mm	No. of nails pr connection	Load Duration	F1, [kN]	F2 /F3, [kN]	F4 /F5, [kN]
Holes marked blue	44	P	4,79	6,80	$2,4 \cdot (17,5+b)/e$, max ↓ 10,31
		L	5,59	7,94	$2,8 \cdot (17,5+b)/e$, max ↓ 12,03
		M	6,38	9,07	$3,2 \cdot (17,5+b)/e$, max ↓ 13,75
		S	7,18	10,21	$3,6 \cdot (17,5+b)/e$, max ↓ 15,47
		I	8,78	12,47	$4,4 \cdot (17,5+b)/e$, max ↓ 18,91
Characteristic values, b and e in mm			7,98	11,34	$4,0 \cdot (17,5+b)/e$, max ↓ 17,19

2 angle brackets V6, beam to beam connection

Paslode Connector nails 4,0 x 40 mm	No. of nails pr connection	Load Duration	F1, [kN]	F2 /F3, [kN]	F4 /F5, [kN]
Holes marked blue	18	P	3,42	3,07	$1,96*(20,5+b)/e$ or $2,26*(2+b)/e$, max ↓ 5,66
		L	3,42	3,58	$2,29*(20,5+b)/e$ or $2,64*(2+b)/e$, max ↓ 6,60
		M	3,42	4,09	$2,61*(20,5+b)/e$ or $3,02*(2+b)/e$, max ↓ 7,54
		S	3,42	4,60	$2,94*(20,5+b)/e$ or $3,39*(2+b)/e$, max ↓ 8,49
		I	3,42	5,62	$3,60*(20,5+b)/e$ or $4,15*(2+b)/e$, max ↓ 10,37
Characteristic values, b and e in mm			3,42	5,11	$3,27*(20,5+b)/e$ or $3,77*(2+b)/e$, max ↓ 9,43

2 angle brackets V7, beam to beam connection

Paslode Connector nails 4,0 x 40 mm	No. of nails pr connection	Load Duration	F1, [kN]	F2 /F3, [kN]	F4 /F5, [kN]
Holes marked blue	16	P	2,39	3,07	$1,2*(17+b)/e$, max ↓ 4,52
		L	2,79	3,58	$1,4*(17+b)/e$, max ↓ 5,28
		M	3,19	4,09	$1,6*(17+b)/e$, max ↓ 6,03
		S	3,59	4,60	$1,8*(17+b)/e$, max ↓ 6,79
		I	4,39	5,62	$2,2*(17+b)/e$, max ↓ 8,29
Characteristic values, b and e in mm			3,99	5,11	$2,0*(17+b)/e$, max ↓ 7,53

2 angle brackets V7PL, beam to beam connection

Paslode Connector nails 4,0 x 40 mm	No. of nails pr connection	Load Duration	F1, [kN]	F2 /F3, [kN]	F4 /F5, [kN]
Holes marked blue	16	P	2,39	3,07	$1,2*(16,5+b)/e$, max ↓ 4,52
		L	2,79	3,58	$1,4*(16,5+b)/e$, max ↓ 5,28
		M	3,19	4,09	$1,6*(16,5+b)/e$, max ↓ 6,03
		S	3,59	4,60	$1,8*(16,5+b)/e$, max ↓ 6,79
		I	4,39	5,62	$2,2*(16,5+b)/e$, max ↓ 8,29
Characteristic values, b and e in mm			3,99	5,11	$2,0*(16,5+b)/e$, max ↓ 7,53

1 angle bracket V8, wood to concrete connection

Paslode Connector nails 4,0 × 40 mm / Expansion bolt	No. of fasteners pr connection	Load Duration	F1, [kN]	F2 /F3, [kN]	F4, [kN]	F5, [kN]
Holes marked green	4 nails	P	1,98	1,90	21,5/e max ↓ 5,35	1,33
		L	1,98	1,90	21,5/e max ↓ 6,24	1,33
		M	1,98	1,90	21,5/e max ↓ 7,13	1,33
Hole marked yellow	1 bolt	S	1,98	1,90	21,5/e max ↓ 8,02	1,33
		I	1,98	1,90	21,5/e max ↓ 9,80	1,33
Characteristic values, b and e in mm			1,98	1,90	21,5/e max ↓ 8,91	1,33

1 angle bracket V8, beam to beam connection

Paslode Connector nails 4,0 × 40 mm	No. of nails pr connection	Load Duration	F1, [kN]	F2 /F3, [kN]	F4, [kN]	F5, [kN]
Holes marked blue	10 nails	P	1,75	1,98	21,5/e max ↓ 5,35	1,33
		L	2,04	2,31	21,5/e max ↓ 6,24	1,33
		M	2,32	2,64	21,5/e max ↓ 7,13	1,33
		S	2,61	2,97	21,5/e max ↓ 8,02	1,33
		I	3,19	3,63	21,5/e max ↓ 9,80	1,33
Characteristic values, b and e in mm			2,90	3,30	21,5/e max ↓ 8,91	1,33

2 angle brackets V8, beam to beam connection

Paslode Connector nails 4,0 × 40 mm	No. of nails pr connection	Load Duration	F1, [kN]	F2 /F3, [kN]	F4 /F5, [kN]
Holes marked blue	20 nails	P	3,48	3,96	1,85*(15+b)/e, max ↓ 5,63
		L	4,06	4,62	2,16*(15+b)/e, max ↓ 6,57
		M	4,64	5,28	2,46*(15+b)/e, max ↓ 7,50
		S	5,22	5,94	2,77*(15+b)/e, max ↓ 8,44
		I	6,38	7,26	3,39*(15+b)/e, max ↓ 10,32
Characteristic values, b and e in mm			5,80	6,60	3,08*(15+b)/e, max ↓ 9,38

1 angle bracket V10 2,5, beam to beam connection

Paslode Connector nails 4,0 x 40 mm	No. of nails pr connection	Load Duration	F1, [kN]	F2 /F3, [kN]	F4, [kN]	F5, [kN]
Holes marked blue	8	P	1,2	1,03	15,6/e, max ↓ 2,63	4,52*(2,5+b)/e, max ↓ 1,2
		L	1,4	1,20	15,6/e, max ↓ 3,07	5,28*(2,5+b)/e, max ↓ 1,4
		M	1,6	1,37	15,6/e, max ↓ 3,50	6,03*(2,5+b)/e, max ↓ 1,6
		S	1,6	1,55	15,6/e, max ↓ 3,94	6,79*(2,5+b)/e, max ↓ 1,6
		I	1,6	1,89	15,6/e, max ↓ 4,82	8,29*(2,5+b)/e, max ↓ 1,6
Characteristic values, b and e in mm			1,6	1,72	15,6/e, max ↓ 4,38	7,54*(2,5+b)/e, max ↓ 1,6

2 angle brackets V10 2,5, beam to beam connection

Paslode Connector nails 4,0 x 40 mm	No. of nails pr connection	Load Duration	F1, [kN]	F2 /F3, [kN]	F4 /F5, [kN]
Holes marked blue	16	P	2,39	2,07	1,2*(21+b)/e, max ↓ 4,52
		L	2,79	2,42	1,4*(21+b)/e, max ↓ 5,28
		M	3,19	2,76	1,6*(21+b)/e, max ↓ 6,03
		S	3,19	3,11	1,8*(21+b)/e, max ↓ 6,79
		I	3,19	3,80	2,2*(21+b)/e, max ↓ 8,29
Characteristic values, b and e in mm			3,19	3,45	2,0*(21+b)/e, max ↓ 7,54

1 angle bracket V10, beam to beam connection

Paslode Connector nails 4,0 x 40 mm	No. of nails pr connection	Load Duration	F1, [kN]	F2 /F3, [kN]	F4, [kN]	F5, [kN]
Holes marked blue	8	P	1,23	0,49	22,5/e, max ↓ 2,61	1,23
		L	1,44	0,57	22,5/e, max ↓ 3,05	1,44
		M	1,64	0,66	22,5/e, max ↓ 3,48	1,64
		S	1,85	0,75	22,5/e, max ↓ 3,92	1,85
		I	2,26	0,90	22,5/e, max ↓ 4,79	2,26
Characteristic values, b and e in mm			2,05	0,82	22,5/e, max ↓ 4,35	2,05

2 angle brackets V10, beam to beam connection

Paslode Connector nails 4,0 × 40 mm	No. of nails pr connection	Load Duration	F1, [kN]	F2 /F3, [kN]	F4 /F5, [kN]
Holes marked blue	16	P	2,47	0,98	1,23*(19,5+b)/e max ↓ 4,51
		L	2,88	1,15	1,44*(19,5+b)/e max ↓ 5,26
		M	3,29	1,31	1,64*(19,5+b)/e max ↓ 6,01
		S	3,70	1,48	1,85*(19,5+b)/e max ↓ 6,76
		I	4,52	1,80	2,26*(19,5+b)/e max ↓ 8,26
Characteristic values, b and e in mm			4,11	1,64	2,05*(19,5+b)/e max ↓ 7,51

1 angle bracket V12, beam to concrete connection

Paslode Connector nails 4,0 × 40 mm / Expansion bolt	No. of fasteners pr connection	Load Duration	F1, [kN]	F2 /F3, [kN]	F4, [kN]	F5, [kN]
Holes marked blue	6 nails	P	1,86	1,96	28,10/e, max ↓ 16,26	6,41*b/e, max ↓ 1,58
		L	1,86	2,29	28,10/e, max ↓ 16,26	7,48*b/e, max ↓ 1,58
		M	1,86	2,62	28,10/e, max ↓ 16,26	8,55*b/e, max ↓ 1,58
Hole marked yellow	1 bolt	S	1,86	2,94	28,10/e, max ↓ 16,26	9,62*b/e, max ↓ 1,58
		I	1,86	3,60	28,10/e, max ↓ 16,26	11,76*b/e, max ↓ 1,58
Characteristic values, b and e in mm			1,86	3,27	28,10/e, max ↓ 16,26	10,69*b/e, max ↓ 1,58

2 angle brackets V12, beam to concrete connection

Paslode Connector nails 4,0 × 40 mm / Expansion bolt	No. of fasteners pr connection	Load Duration	F1, [kN]	F2 /F3, [kN]	F4 /F5, [kN]
Holes marked blue	12 nails	P	3,72	3,92	10,42
		L	3,72	4,58	12,15
		M	3,72	5,23	13,89
Holes marked yellow	2 bolts	S	3,72	5,89	15,62
		I	3,72	7,19	19,09
Characteristic values			3,72	6,54	17,35

1 angle bracket V12, beam to beam connection

Paslode Connector nails 4,0 × 40 mm	No. of nails pr connection	Load Duration	F1, [kN]	F2 /F3, [kN]	F4, [kN]	F5, [kN]
Holes marked blue	10	P	0,88	1,68	16,86/e, max ↓ 2,14	6,41*b/e, max ↓ 1,58
		L	1,02	1,96	19,67/e, max ↓ 2,14	7,48*b/e, max ↓ 1,58
		M	1,17	2,24	22,48/e, max ↓ 2,14	8,55*b/e, max ↓ 1,58
		S	1,31	2,52	25,49/e, max ↓ 2,14	9,62*b/e, max ↓ 1,58
		I	1,61	3,08	30,91/e, max ↓ 2,14	11,76*b/e, max ↓ 1,58
Characteristic values, b and e in mm			1,46	2,80	28,10/e, max ↓ 2,14	10,69*b/e, max ↓ 1,58

2 angle brackets V12, beam to beam connection

Paslode Connector nails 4,0 × 40 mm	No. of nails pr connection	Load Duration	F1, [kN]	F2 /F3, [kN]	F4 /F5, [kN]
Holes marked blue	20	P	2,39	3,55	1,2*(21+b)/e, max ↓ 2,26
		L	2,79	4,14	1,4*(21+b)/e, max ↓ 2,64
		M	3,19	4,74	1,6*(21+b)/e, max ↓ 3,02
		S	3,59	5,33	1,8*(21+b)/e, max ↓ 3,39
		I	4,39	6,51	2,2*(21+b)/e, max ↓ 4,15
Characteristic values, b and e in mm			3,99	5,92	2,0*(21+b)/e, max ↓ 3,76

2 angle brackets V13, beam to beam connection

Paslode Connector nails 4,0 × 40 mm	No. of nails pr connection	Load Duration	F1, [kN]	F2 /F3, [kN]	F4 /F5, [kN]
Holes marked blue	24	P	2,39	4,95	1,2*(22+b)/e, max ↓ 2,26
		L	2,79	5,78	1,4*(22+b)/e, max ↓ 2,64
		M	3,19	6,6	1,6*(22+b)/e, max ↓ 3,02
		S	3,59	7,43	1,8*(22+b)/e, max ↓ 3,39
		I	4,39	9,08	2,2*(22+b)/e, max ↓ 4,15
Characteristic values, b and e in mm			3,98	8,25	2,0*(22+b)/e, max ↓ 3,77

2 angle brackets V14, beam to beam connection

Paslode Connector nails 4,0 × 40 mm	No. of nails pr connection	Load Duration	F1, [kN]	F2 /F3, [kN]	F4 /F5, [kN]
Holes marked blue	34	P	4,79	8,48	$2,4*(20+b)/e$, max ↓ 4,52
		L	5,59	9,89	$2,8*(20+b)/e$, max ↓ 5,28
		M	6,38	11,30	$3,2*(20+b)/e$, max ↓ 6,03
		S	7,18	12,72	$3,6*(20+b)/e$, max ↓ 6,79
		I	8,78	15,54	$4,4*(20+b)/e$, max ↓ 8,29
Characteristic values, b and e in mm			7,98	14,13	$4,0*(20+b)/e$, max ↓ 7,54

2 angle brackets V15, beam to beam connection

Paslode Connector nails 4,0 × 40 mm	No. of nails pr connection	Load Duration	F1, [kN]	F2 /F3, [kN]	F4 /F5, [kN]
Holes marked blue	24	P	1,60	2,57	$1,45*(42,9+b)/e$, max ↓ 4,52
		L	1,86	3,00	$1,69*(42,9+b)/e$, max ↓ 5,28
		M	2,13	3,42	$1,93*(42,9+b)/e$, max ↓ 6,03
		S	2,39	3,85	$2,17*(42,9+b)/e$, max ↓ 6,79
		I	2,93	4,71	$2,65*(42,9+b)/e$, max ↓ 8,29
Characteristic values, b and e in mm			2,67	4,28	$2,41*(42,9+b)/e$, max ↓ 7,54

1 angle bracket V20, wood to concrete

Paslode Connector nails 4,0 × 40 mm / Expansion bolt	No. of fasteners pr connection	Load Duration	F1, [kN]	F2/F3, [kN]	F4, [kN]	F5, [kN]
Holes marked blue	4 nails	P	1,56	1,63	$15,6/e$, max ↓ 7,83	1,09
		L	1,56	1,90	$15,6/e$, max ↓ 9,14	1,09
		M	1,56	2,18	$15,6/e$, max ↓ 10,44	1,09
Hole marked yellow	1 bolt	S	1,56	2,45	$15,6/e$, max ↓ 10,69	1,09
		I	1,56	2,99	$15,6/e$, max ↓ 10,69	1,09
Characteristic values, b and e in mm			1,56	2,72	$15,6/e$, max ↓ 13,05	1,09

2 angle brackets V20, wood to concrete

Paslode Connector nails 4,0 × 40 mm / Expansion bolt	No. of fasteners pr connection	Load Duration	F1, [kN]	F2 /F3, [kN]	F4 /F5, [kN]
Holes marked blue	8 nails	P	3,12	3,27	7,83
		L	3,12	3,82	9,14
		M	3,12	4,36	10,44
Holes marked yellow	2 bolts	S	3,12	4,91	10,69
		I	3,12	6,00	10,69
Characteristic values			3,12	5,45	13,05

1 angle bracket V21, wood to concrete

Paslode Connector nails 4,0 × 40 mm / Expansion bolt	No. of fasteners pr connection	Load Duration	F1, [kN]	F2 /F3, [kN]	F4, [kN]	F5, [kN]
Holes marked blue	8 nails	P	1,23	1,47	20,5/e, max ↓ 19,8	10,69*b/e, max ↓ 1,31
		L	1,23	1,72	20,5/e, max ↓ 19,8	12,47*b/e, max ↓ 1,31
		M	1,23	1,96	20,5/e, max ↓ 19,8	14,25*b/e, max ↓ 1,31
Hole marked yellow	1 bolts	S	1,23	2,21	20,5/e, max ↓ 19,8	16,03*b/e, max ↓ 1,31
		I	1,23	2,70	20,5/e, max ↓ 19,8	19,59*b/e, max ↓ 1,31
Characteristic values, b and e in mm			1,23	2,45	20,5/e, max ↓ 19,8	17,82*b/e, max ↓ 1,31

2 angle brackets V21, wood to concrete

Paslode Connector nails 4,0 × 40 mm / Expansion bolt	No. of fasteners pr connection	Load Duration	F1, [kN]	F2 /F3, [kN]	F4 /F5, [kN]
Holes marked blue	16 nails	P	2,47	2,94	14,64
		L	2,47	3,43	17,08
		M	2,47	3,92	19,52
Holes marked yellow	2 bolts	S	2,47	4,41	19,80
		I	2,47	5,39	19,80
Characteristic values			2,47	4,90	19,80

1 angle bracket V21, beam to beam connection

Paslode Connector nails 4,0 × 40 mm	No. of nails pr connection	Load Duration	F1, [kN]	F2 /F3, [kN]	F4, [kN]	F5, [kN]
Holes marked blue	12	P	0,88	1,47	22,5/e, max ↓ 2,14	10,69*b/e, max ↓ 1,31
		L	1,02	1,72	22,5/e, max ↓ 2,49	12,47*b/e, max ↓ 1,31
		M	1,17	1,96	22,5/e, max ↓ 2,85	14,25*b/e, max ↓ 1,31
		S	1,31	2,21	22,5/e, max ↓ 3,20	16,03*b/e, max ↓ 1,31
		I	1,61	2,70	22,5/e, max ↓ 3,92	19,59*b/e, max ↓ 1,31
Characteristic values, b and e in mm			1,46	2,45	22,5/e, max ↓ 3,56	17,82*b/e, max ↓ 1,31

1 angle bracket V170, beam to concrete connection

Paslode Connector nails 4,0 × 40 mm / Expansion bolt	No. of fasteners pr connection	Load Duration	F1, [kN]	F2 /F3, [kN]	F4, [kN]	F5, [kN]
Holes marked blue	16 nails	P	18,02	4,45	19,79	2,47
		L	21,02	5,19	23,09	2,88
		M	24,02	5,94	26,39	3,29
Holes marked yellow	4 bolt	S	27,03	6,68	29,69	3,70
		I	33,03	8,16	36,29	4,52
Characteristic values, b and e in mm			30,03	7,42	32,99	4,11

2 angle brackets V170, beam to concrete connection

Paslode Connector nails 4,0 × 40 mm / Expansion bolt	No. of fasteners pr connection	Load Duration	F1, [kN]	F2 /F3, [kN]	F4 /F5, [kN]
Holes marked blue	32 nails	P	36,04	8,90	18,02*b/e, max ↓ 19,79
		L	42,04	10,39	21,02*b/e max ↓ 23,09
		M	48,05	11,87	24,02*b/e max ↓ 26,39
Holes marked yellow	8 bolts	S	54,05	13,36	27,03*b/e max ↓ 29,69
		I	66,07	16,32	33,03*b/e max ↓ 36,29
Characteristic values			60,06	14,84	30,03*b/e max ↓ 32,99

1 angle bracket V170, beam to beam connection

Paslode Connector nails 4,0 × 40 mm	No. of nails pr connection	Load Duration	F1, [kN]	F2 /F3, [kN]	F4, [kN]	F5, [kN]
Holes marked blue	16 nails	P	3,70	4,45	9,01	2,47
		L	4,31	5,19	10,51	2,88
		M	4,93	5,94	12,02	3,29
	10 nails	S	5,54	6,68	13,52	3,70
		I	6,78	8,16	16,52	4,52
Characteristic values, b and e in mm			6,16	7,42	15,02	4,11

2 angle brackets V170, beam to beam connection

Paslode Connector nails 4,0 × 40 mm	No. of nails pr connection	Load Duration	F1, [kN]	F2 /F3, [kN]	F4 /F5, [kN]
Holes marked blue	32 nails	P	7,39	8,90	$3,70 \cdot (31+b)/e$ max ↓ 9,01
		L	8,62	10,39	$4,31 \cdot (31+b)/e$ max ↓ 10,51
		M	9,86	11,87	$4,93 \cdot (31+b)/e$ max ↓ 12,02
	20 nails	S	11,09	13,36	$5,54 \cdot (31+b)/e$ max ↓ 13,52
		I	13,55	16,32	$6,78 \cdot (31+b)/e$ max ↓ 16,52
Characteristic values, b and e in mm			12,32	14,84	$6,16 \cdot (31+b)/e$ max ↓ 15,02

1 angle bracket P4, wood to concrete

Paslode Connector nails 4,0 × 40 mm / Expansion bolt	No. of fasteners pr connection	Load Duration	F1, [kN]	F2/F3, [kN]	F4, [kN]	F5, [kN]
Holes marked blue	4 nails	P	2,25	1,19	$22,5/e$, max ↓ 8,11	$5,35 \cdot b/e$, max ↓ 1,03
		L	2,25	1,39	$22,5/e$, max ↓ 9,46	$6,24 \cdot b/e$, max ↓ 1,20
		M	2,25	1,58	$22,5/e$, max ↓ 9,90	$7,13 \cdot b/e$, max ↓ 1,38
Hole marked yellow	1 bolt	S	2,25	1,78	$22,5/e$, max ↓ 9,90	$8,02 \cdot b/e$, max ↓ 1,55
		I	2,25	2,18	$22,5/e$, max ↓ 9,90	$9,80 \cdot b/e$, max ↓ 1,89
Characteristic values, b and e in mm			2,25	1,98	$22,5/e$, max ↓ 9,90	$8,91 \cdot b/e$, max ↓ 1,72

2 angle brackets P4, wood to concrete

Paslode Connector nails 4,0 × 40 mm / Expansion bolt	No. of fasteners pr connection	Load Duration	F1, [kN]	F2 /F3, [kN]	F4 /F5, [kN]
Holes marked blue	8 nails	P	4,5	2,38	9,9
		L	4,5	2,77	9,9
		M	4,5	3,17	9,9
Holes marked yellow	2 bolts	S	4,5	3,56	9,9
		I	4,5	4,36	9,9
Characteristic values			4,5	3,97	9,9

1 angle bracket P4, beam to beam connection

Paslode Connector nails 4,0 × 40 mm	No. of nails pr connection	Load Duration	F1, [kN]	F2 /F3, [kN]	F4, [kN]	F5, [kN]
Holes marked blue	4	P	0,88	1,19	22,5/e, max ↓ 2,14	5,35*b/e, max ↓ 1,21
		L	1,02	1,39	22,5/e, max ↓ 2,49	6,24*b/e, max ↓ 1,41
		M	1,17	1,58	22,5/e, max ↓ 2,85	7,13*b/e, max ↓ 1,61
		S	1,31	1,78	22,5/e, max ↓ 3,20	8,02*b/e, max ↓ 1,81
		I	1,61	2,18	22,5/e, max ↓ 3,92	9,80*b/e, max ↓ 2,21
Characteristic values, b and e in mm			1,46	1,98	22,5/e, max ↓ 3,56	8,91*b/e, max ↓ 2,02

2 angle brackets K4, beam to beam connection

Paslode Connector nails 4,0 × 40 mm	No. of nails pr connection	Load Duration	F1, [kN]	F2 /F3, [kN]	F4 /F5, [kN]
Holes marked blue	34 nails	P	5,16	6,41	6,79
		L	6,02	7,48	7,92
		M	6,88	8,55	9,05
		S	7,74	9,62	10,18
		I	9,46	11,76	12,44
Characteristic values			8,60	10,69	11,31

1 angle bracket 1-150, wood to concrete

Expansion bolt	No. of bolts pr connection	Load Duration	F1, [kN]
Holes marked yellow	1 bolt	P	4,12
		L	4,80
		M	5,49
	1 bolt	S	6,17
		I	7,55
Characteristic values			6,86

2 angle brackets LV1, beam to beam connection

Paslode Connector nails 4,0 × 40 mm	No. of nails pr connection	Load Duration	F1, [kN]	F2 /F3, [kN]	F4 /F5, [kN]
Holes marked blue	20 nails	P	1,89	1,30	$1,44 \cdot (20,7+b)/e$, max ↓ 4,52
		L	2,20	1,51	$1,68 \cdot (20,7+b)/e$, max ↓ 5,28
		M	2,52	1,73	$1,92 \cdot (20,7+b)/e$, max ↓ 6,03
		S	2,83	1,94	$2,16 \cdot (20,7+b)/e$, max ↓ 6,79
		I	3,46	2,38	$2,64 \cdot (20,7+b)/e$, max ↓ 8,29
Characteristic values, b and e in mm			3,15	2,16	$2,40 \cdot (20,7+b)/e$, max ↓ 7,53

Angle Bracket V26, V27
Design Basis

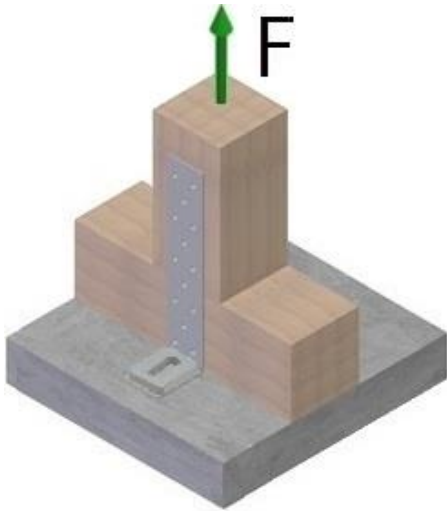

Figure 4. Force, 1 or 2 brackets, wood to concrete
 F_n

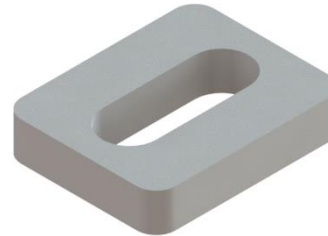

Figure 5. Example of washer, 40 x 50 x 10 mm

It must be checked that the bolts used have the necessary strength. Angle brackets with same dimensions where only the length is different may also use these values.

Fastening with bolts and nails:

F With the use of a washer with a thickness of 10 mm or more and n number of nails

Fastening with nails:

F_n Angle without the use of a washer and mounted with nails in wood

The values have been assessed in accordance with EC 5 Table 3.1- "Values of K_{mod} " where needed

1 angle bracket V26 – V27, wood to concrete

Paslode Connector nails 4,0 x 40 mm / Expansion bolt	No. of fasteners pr connection	Load Duration	F , [kN]
Nailing holes	n number of nails	P	1,13*n, max ↑ 17,82
		L	1,32*n, max ↑ 17,82
		M	1,50*n, max ↑ 17,82
Hole marked yellow	1 bolt	S	1,69*n, max ↑ 17,82
		I	2,07*n, max ↑ 17,82
Characteristic values			1,88*n, max ↑ 17,82

2 angle brackets V26 – V27, wood to concrete

Paslode Connector nails 4,0 × 40 mm / Expansion bolt	No. of fasteners pr connection	Load Duration	F, [kN]
Nailing holes	n number of nails	P	2,25*n, max ↑ 35,64
		L	2,63*n, max ↑ 35,64
		M	3,00*n, max ↑ 35,64
Holes marked yellow	2 bolts	S	3,38*n, max ↑ 35,64
		I	4,13*n, max ↑ 35,64
Characteristic values			3,75*n, max ↑ 35,64

1 angle bracket V26 – V27, wood to wood

Paslode Connector nails 4,0 × 40 mm	No. of nails pr connection	Load Duration	F _n , [kN]
Nailing holes	n number of nails	P	1,13*n, max ↑ 1,23
		L	1,32*n, max ↑ 1,44
		M	1,50*n, max ↑ 1,64
Hole marked blue	4 nails	S	1,69*n, max ↑ 1,85
		I	2,07*n, max ↑ 2,26
Characteristic values			1,88*n, max ↑ 2,05

2 angle brackets V26 – V27, wood to wood

Paslode Connector nails 4,0 × 40 mm	No. of nails pr connection	Load Duration	F _n , [kN]
Nailing holes	n number of nails	P	2,25*n, max ↑ 2,47
		L	2,63*n, max ↑ 2,88
		M	3,00*n, max ↑ 3,29
Holes marked blue	8 nails	S	3,38*n, max ↑ 3,70
		I	4,13*n, max ↑ 4,52
Characteristic values			3,75*n, max ↑ 4,11

Angle Bracket P1-8, P1-10, P1-12, P2-10, P2-12
Design Basis

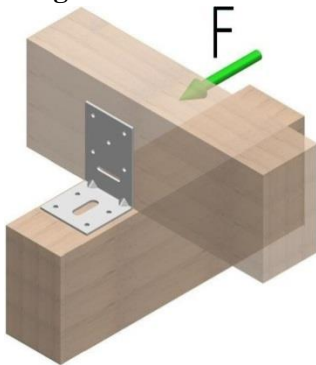

Figure 6. Force, 1 bracket wood to wood, beam to beam

One angle bracket per connection

F Lateral force acting in the beam direction perpendicular to the vertical flap directed towards the angle brackets vertical flap.

The values have been assessed in accordance with EC 5 Table 3.1- "Values of K_{mod} "

Wane

For F wane is allowed on the side towards the angle bracket with an extent from the bottom to the lower row of nails. For all other forces wane is not allowed under the angle bracket.

1 angle bracket P1-8, beam to beam connection

Paslode Connector nails 4,0 × 40 mm	No. of nails pr connection	Load Duration	F, [kN]
Holes marked blue	9	P	2,26
		L	2,64
		M	3,02
		S	3,39
		I	4,15
Characteristic values			3,77

1 angle bracket P1-10, beam to beam connection

Paslode Connector nails 4,0 × 40 mm	No. of nails pr connection	Load Duration	F, [kN]
Holes marked blue	9	P	4,52
		L	5,28
		M	6,03
		S	6,79
		I	8,29
Characteristic values			7,54

1 angle bracket P1-12, beam to beam connection

Paslode Connector nails 4,0 × 40 mm	No. of nails pr connection	Load Duration	F, [kN]
Holes marked blue	9	P	4,52
		L	5,28
		M	6,03
		S	6,79
		I	8,29
Characteristic values			7,54

1 angle bracket P2-10, beam to beam connection

Paslode Connector nails 4,0 × 40 mm	No. of nails pr connection	Load Duration	F, [kN]
Holes marked blue	9	P	4,52
		L	5,28
		M	6,03
		S	6,79
		I	8,29
Characteristic values			7,54

1 angle bracket P2-12, beam to beam connection

Paslode Connector nails 4,0 × 40 mm	No. of nails pr connection	Load Duration	F, [kN]
Holes marked blue	9	P	4,52
		L	5,28
		M	6,03
		S	6,79
		I	8,29
Characteristic values			7,54