



HS 1-phase
50Hz

Light duty drainage pump
- for professional use

The TSURUMI HS-pump is a small and robust submersible contractor's pump with a wide range of applications wherever water has to be moved.



Side discharge

The spiral type pump features a large waterway area as illustrated and carries sand suspensions or slurry very effectively. Since a high performance motor is used, the pump can be run continuously in air.

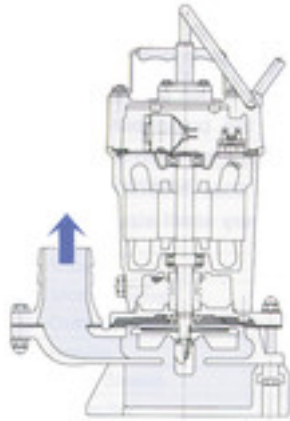

Long life, low maintenance

No wear plate to replace. Impeller made of urethane rubber, pump casing made of ductile iron casting.

Tough casing

Withstands abrasion, provides long service, high throughput. Remove only three bolts for easy access to the impeller.

New designed Motor

Aluminium casting motor frame is superior to motor cooling and ensures the light weight.

Components:

001 Cable	050 Motor cover
020 Pump casing	051 Head cover
021 Impeller	052A Upper bearing
023 Strainer	052B Lower bearing
024 Agitator	053 Motor protector
025 Mechanical seal	054 Shaft
026 Oil sealing	055 Rotor
029 Oil casing	056 Stator
030 Oil lifter	064 Motor casing
032. Outlet	068 Handle
035 Oil plug	071 Shaft sleeve
036 Lubricant	076 Condensor

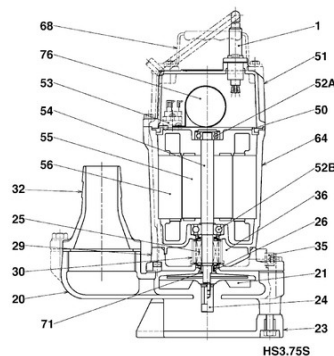

Specifications:

Model	Colour code curve	Bore mm	Motor output kW	Rated current A	Head max. m	Capacity max. l/min	Dry weight kg w/o cable	Max. solid handling ø mm	Pressure resistance max. m	Cable length m
HS2.4S	1	50	0,4	2,6	12,2	207	11,3	7	10	10
HS2.75S	2	50	0,75	4,8	18,0	230	19,0	7	10	10
HS3.75S	3	80	0,75	4,8	18,0	300	19,6	7	10	10
HS3.75SL	4	80	0,75	4,8	10,8	580	19,6	7	10	10

ø Discharge bore mm		50, 80	
Pumping Fluid	Type of Fluid	Spring water, Rain water, Ground water, Sand carrying water	
	Temperature	0-40°C	
Pump	Components	Impeller	Semi-Vortex impeller
		Shaft Seal	Double mechanical seal
		Bearings	Shielded ball bearings
	Material	Impeller	Urethane rubber
		Casing	Ductile iron casting EN-GJS-700-2
Shaft Seal	Silicon carbide in oil bath		
Motor	Phase / Voltage		Single phase 230V / 110V / 50Hz
	Motor Protector (built-in)		Miniature protector
	Type, Poles		Induction motor, 2 poles, IP68
	Insulation		Insulation class E
	Lubrication		Turbine oil (ISO VG32)
	Material	Casing	Aluminium die casting
		Shaft	Stainless steel EN-X6Cr13
Cable		Rubber, 10m H07RN8-F	
Discharge Connection		Threaded flange/Hose coupling	

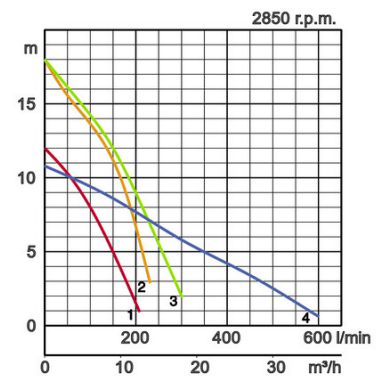

Dimensions in mm:

Model	d	A	A1	B	B1	D	H	W1
HS2.4S	50	240	207	158	84	185	358	90
HS2.75S	50	285	233	217	109	184	424	90
HS3.75S	80	285	233	217	109	184	424	90
HS3.75SL	80	317	233	217	141	184	454	120

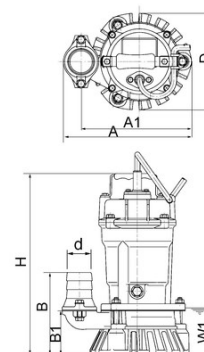

W1: lowest running water level

In the event of abrasive and corrosive utilization, stronger wear and tear will take place naturally in certain components. In this regard, please pay attention to our website www.tsurumi.eu/english/applications.htm.



Contributing to World-wide Prosperity and Understanding through Worker- and Environment-friendly Production.

Designed for increased productivity through fully integrated streamlined production systems, Tsurumi's factory in Kyoto (Japan) features a production capacity of a full 1 million pumps per year. Large-scale modern R&D facilities offer optimum conditions for experimenting and testing of even super-large pumps and for developing new products to expand the possibilities and applications of pumps. To provide optimum conditions for our main asset, our workers, as well as for the environment, special emphasis is placed on optimized working conditions with airconditioning, minimized dust and exhaust gas emission, comprehensive recycling and waste recovery.

Tsurumi (Europe) GmbH

Wahlerstr. 10
D-40472 Düsseldorf
Tel.: +49 (0)211-4179373
Fax: +49 (0)211-417937-480
Email: sales@tsurumi.eu
www.tsurumi.eu

We reserve the right to change specifications and designs herein for improvement without prior notice. Our pumps are for professional use only. In the event that Tsurumi (Europe) GmbH have, in exceptional cases taken over, a manufacturer's warranty, this entitles the enduser to assert remedy free of charge against Tsurumi (Europe) GmbH due to any defect to the product occurring during the guarantee period (see below), also then when the warranty claims against the seller do not or no longer exist. In the event of malfunction, which is attributable to the improper handling by the enduser, no guarantee claim shall arise. Further claims shall not result from the warranty, unless if something to the contrary has explicitly been determined. The decision as to whether remedy is effected by way of replacement or repair shall be at the choice of Tsurumi (Europe) GmbH. The claims shall be time barred after a period of three months after expiry of the guarantee period, however, not before expiry of the warranty period which is valid towards the seller. In the event of doubt, the warranty period shall correspond with the warranty period which is valid between the end-user and his seller.



com-HS-EN