

Approval body for construction products  
and types of construction

Bautechnisches Prüfamt

An institution established by the Federal and  
Laender Governments



## European Technical Assessment

ETA-15/0373  
of 30 September 2016

English translation prepared by DIBt - Original version in German language

### General Part

Technical Assessment Body issuing the  
European Technical Assessment:

Deutsches Institut für Bautechnik

Trade name of the construction product

Fixplug 8 and Fixplug 10

Product family  
to which the construction product belongs

Nailed-in plastic anchor for fixing of external thermal  
insulation composite systems with rendering in concrete  
and masonry

Manufacturer

Klimas Sp. z o.o.  
Kuznica Kiedrzynska  
ul. Wincentego Witosa 135/137  
42-233 MYKANÓW  
POLEN

Manufacturing plant

Klimas Sp. z o.o.

This European Technical Assessment  
contains

12 pages including 3 annexes which form an integral part  
of this assessment

This European Technical Assessment is  
issued in accordance with Regulation (EU)  
No 305/2011, on the basis of

Guideline for European technical approval of "Plastic  
anchors for fixing of external thermal insulation composite  
systems with rendering", ETAG 014, edition  
February 2011,  
used as European Assessment Document (EAD)  
according to Article 66 Paragraph 3 of Regulation (EU)  
No 305/2011.

The European Technical Assessment is issued by the Technical Assessment Body in its official language. Translations of this European Technical Assessment in other languages shall fully correspond to the original issued document and shall be identified as such.

Communication of this European Technical Assessment, including transmission by electronic means, shall be in full. However, partial reproduction may only be made with the written consent of the issuing Technical Assessment Body. Any partial reproduction shall be identified as such.

This European Technical Assessment may be withdrawn by the issuing Technical Assessment Body, in particular pursuant to information by the Commission in accordance with Article 25(3) of Regulation (EU) No 305/2011.

## Specific part

### 1 Technical description of the product

The nailed-in anchor Fixplug consists of an anchor sleeve with an enlarged shaft, spreading zone subsequently, an insulation plate made of polyethylene and an accompanying specific nail of glass fibre reinforced polyamide. The serrated expanding part of the anchor sleeve is slotted. An illustration and the description of the product are given in Annex A.

### 2 Specification of the intended use in accordance with the applicable European Assessment Document

The performances given in Section 3 are only valid if the anchor is used in compliance with the specifications and conditions given in Annex B.

The verifications and assessment methods on which this European Technical Assessment is based lead to the assumption of a working life of the anchor of at least 25 years. The indications given on the working life cannot be interpreted as a guarantee given by the producer, but are to be regarded only as a means for choosing the right products in relation to the expected economically reasonable working life of the works.

### 3 Performance of the product and references to the methods used for its assessment

#### 3.1 Mechanical resistance and stability (BWR 1)

The essential characteristics regarding mechanical resistance and stability are included under the Basic Works Requirement Safety in use.

#### 3.2 Hygiene, health and the environment (BWR 3)

Regarding dangerous substances there may be requirements (e.g. transposed European legislation and national laws, regulations and administrative provisions) applicable to the products falling within the scope of this European Technical Assessment. In order to meet the provisions of Regulation (EU) No 305/2011, these requirements need also to be complied with, when and where they apply.

#### 3.3 Safety in use (BWR 4)

Essential characteristic	Performance
Characteristic tension resistance	See Annex C 1
Edge distances and spacing	See Annex B 2
Point thermal transmittance	See Annex C 2
Plate stiffness	See Annex C 2
Displacements	See Annex C 2

**3.4 Sustainable use of natural resources (BWR 7)**

For the sustainable use of natural resources no performance was determined for this product.

**4 Assessment and verification of constancy of performance (AVCP) system applied, with reference to its legal base**

In accordance with guideline for European technical approval ETAG 014, February 2011 used as European Assessment Document (EAD) according to Article 66 Paragraph 3 of Regulation (EU) No 305/2011 the applicable European legal act is: 97/463/EC.

The system to be applied is: 2+

**5 Technical details necessary for the implementation of the AVCP system, as provided in the applicable EAD**

Technical details necessary for the implementation of the AVCP system are laid down in the control plan deposited at Deutsches Institut für Bautechnik.

Issued in Berlin on 30 September 2016 by Deutsches Institut für Bautechnik

Andreas Kummerow  
p. p. Head of Department

*beglaubigt:*  
Ziegler

Fixplug 8 / Fixplug 10

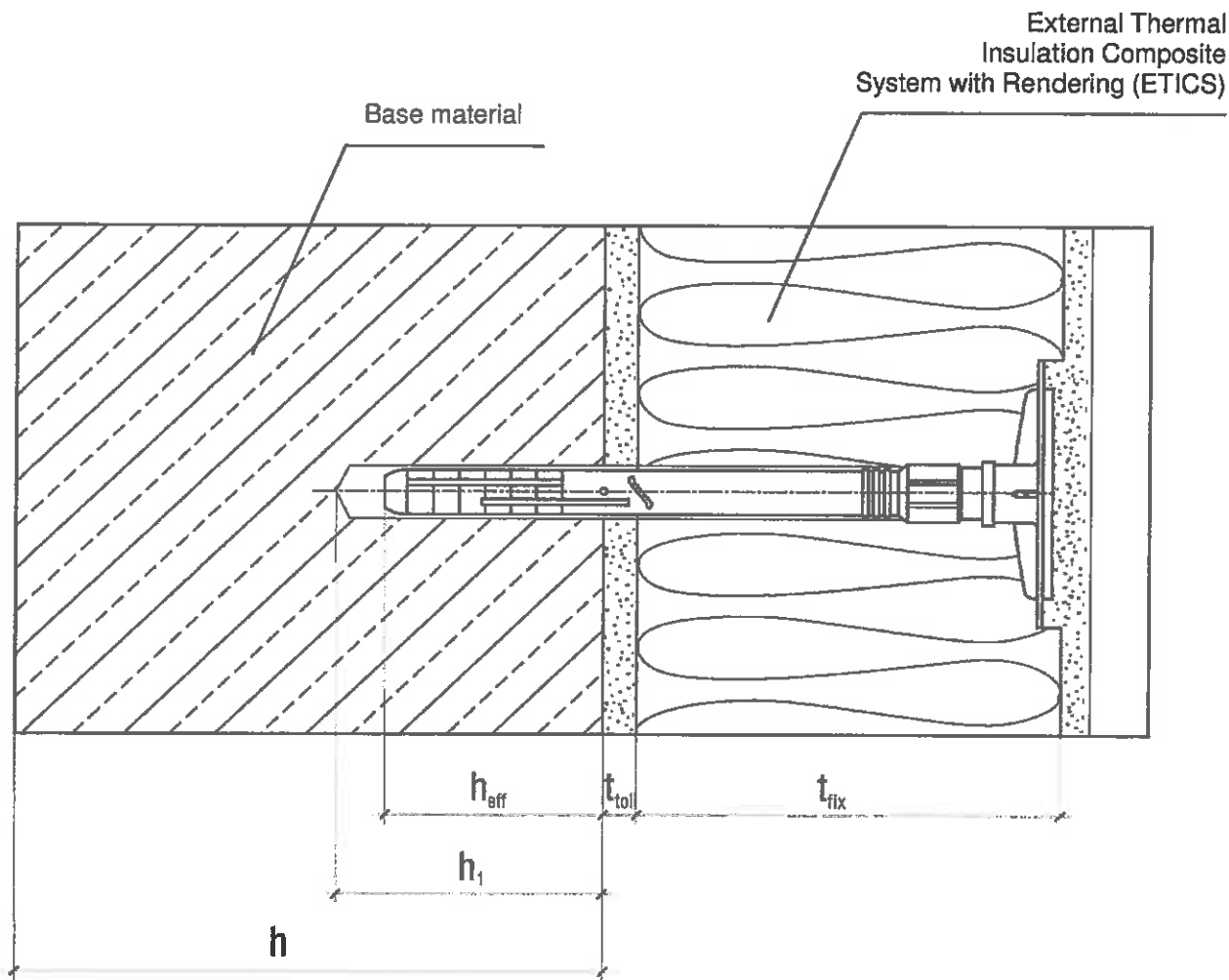

**Intended use**

Anchorage of ETICS in concrete, masonry and in autoclaved aerated concrete

**Legend:**

- $h_{\text{eff}}$  = effective anchorage depth
- $h_1$  = depth of drilled hole to deepest point
- $h$  = thickness of member (wall)
- $t_{\text{fix}}$  = thickness of insulation material
- $t_{\text{tol}}$  = thickness of equalizing layer or non-load-bearing coating

**FIXPLUG 8 and FIXPLUG 10**

**Product description**  
Installed condition

**Annex A 1**

Marking of the anchor sleeve  
Marking of effective anchorage depth

FIXPLUG 8

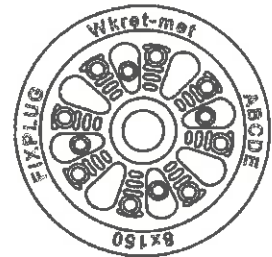
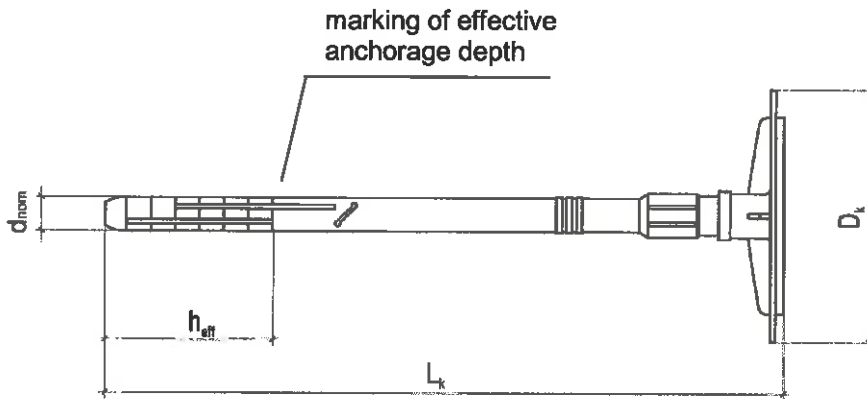

Marking:  
(anchor plate)  
Identifying mark (Wkret-met)  
Anchor type (FIXPLUG)  
Use category (ABCDE)  
diameter x length (e.g. 8x150)

Accompanying specific nail TFP-5,0



marking of effective anchorage depth for AB

marking of effective anchorage depth for CDE

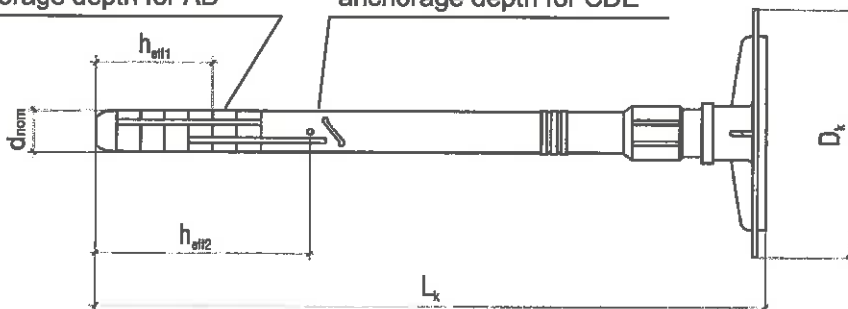

FIXPLUG 10



Marking:  
(anchor plate)  
Identifying mark (Wkret-met)  
Anchor type (FIXPLUG)  
Use category (ABCDE)  
diameter x length (e.g. 10x160)

Accompanying specific nail TFP-6,1

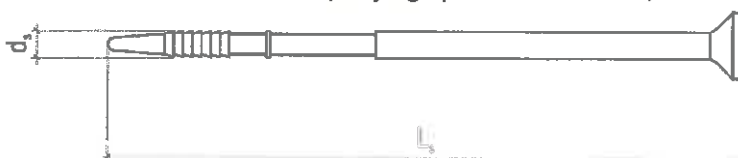

FIXPLUG 8 and FIXPLUG 10

Product description  
Marking of the anchor sleeve

Annex A 2

**Table A1: Dimensions**

Anchor type	Anchor sleeve					Nail		
	$d_{nom} \pm 0,1$	$\min L_k \pm 0,2$	$\max L_k \pm 0,2$	$D \pm 0,2$	$h_{eff}$ (ABCDE)	$d_s \pm 0,1$	$\min L_s \pm 0,2$	$\max L_s \pm 0,2$
	[mm]	[mm]	[mm]	[mm]	[mm]	[mm]	[mm]	[mm]
FIXPLUG 8	8	99	299	60	40	5,0	89	289

Determination of maximum thickness of insulation  $t_{fix}$  for use category ABCDE:

$$t_{fix} = L_k - t_{tol} - h_{eff} \quad (\text{e.g. } L_k = 150 \text{ mm, } t_{tol} = 10 \text{ mm})$$

e.g.  $t_{fix} = 150 - 10 - 40$

$$t_{fix} = 100 \text{ mm}$$

Anchor type	Anchor sleeve						Nail		
	$d_{nom} \pm 0,1$	$\min L_k \pm 0,2$	$\max L_k \pm 0,2$	$D \pm 0,2$	$h_{eff1}$ (AB)	$h_{eff2}$ (CDE)	$d_s \pm 0,1$	$\min L_s \pm 0,2$	$\max L_s \pm 0,2$
	[mm]	[mm]	[mm]	[mm]	[mm]	[mm]	[mm]	[mm]	[mm]
FIXPLUG 10	10	94	364	60	28,5	50	6,1	83	353

Determination of maximum thickness of insulation  $t_{fix}$  for use category AB:

$$t_{fix} = L_k - t_{tol} - h_{eff} \quad (\text{e.g. } L_k = 160 \text{ mm, } t_{tol} = 10 \text{ mm})$$

e.g.  $t_{fix} = 160 - 10 - 28,5$

$$t_{fix} = 121,5 \text{ mm}$$

Determination of maximum thickness of insulation  $t_{fix}$  for use category CDE:

$$t_{fix} = L_k - t_{tol} - h_{eff} \quad (\text{e.g. } L_k = 160 \text{ mm, } t_{tol} = 10 \text{ mm})$$

e.g.  $t_{fix} = 160 - 10 - 50$

$$t_{fix} = 100 \text{ mm}$$

**Table A2: Materials**

Element	Material
Anchor sleeve	Polyethylene (natural)
Plastic nail	Polyamide + GF (natural or black)

FIXPLUG 8 and FIXPLUG 10

Product description  
Dimensions, materials

Annex A 3

### Specifications of intended use

#### Anchorage subject to:

- The anchor may only be used for transmission of wind suction loads and shall not be used for the transmission of dead loads of the thermal insulation composite system.

#### Base materials:

- Normal weight concrete (use category A) according to Annex C 1
- Solid masonry (use category B), according to Annex C 1
- Hollow or perforated masonry (use category C), according to Annex C 1
- Lightweight aggregate concrete (use category D), according to Annex C 1
- Autoclaved aerated concrete (use category E), according to Annex C 1
- For other base materials of the use categories A, B, C, D or E the characteristic resistance of the anchor may be determined by job site tests according to ETAG 014 Edition February 2011, Annex D.

#### Temperature Range:

- 0°C to +40°C (max. short term temperature +40°C and max. long term temperature +24°C)

#### Design:

- The anchorages are designed in accordance with the ETAG 014 Edition February 2011 under the responsibility of an engineer experienced in anchorages and masonry work.
- Verifiable calculation notes and drawings are prepared taking account of the loads to be anchored. The position of the anchor is indicated on the design drawings.
- Fasteners are only to be used for multiple fixings of thermal insulation composite systems.

#### Installation:

- Hole drilling by the drill modes according to Annex C 1
- Anchor installation carried out by appropriately qualified personnel and under the supervision of the person responsible for technical matters of the site
- Installation temperature from 0°C to +40°C
- Exposure to UV due to solar radiation of the anchor not protected by rendering  $\leq 6$  weeks

FIXPLUG 8 and FIXPLUG 10

Intended use  
Specifications

Annex B 1



**Table B1: Installation parameters**

Anchor type		FIXPLUG 8
Drill hole diameter	$d_o$ [mm] =	8,0
Cutting diameter of drill bit	$d_{cut}$ [mm] ≤	8,45
Depth of drill hole to deepest point for category ABCDE	$h_1$ [mm] ≥	50
Effective anchorage depth in the base material category ABCDE	$h_{eff}$ [mm] ≥	40

Anchor type		FIXPLUG 10
Drill hole diameter	$d_o$ [mm] =	10,00
Cutting diameter of drill bit	$d_{cut}$ [mm] ≤	10,45
Depth of drill hole to deepest point for category AB	$h_1$ [mm] ≥	40
Effective anchorage depth in the base material (category AB)	$h_{eff1}$ [mm] ≥	28,5
Depth of drill hole to deepest point for category CDE	$h_1$ [mm] ≥	60
Effective anchorage depth in the base material (category CDE)	$h_{eff2}$ [mm] ≥	50

**Table B2: Minimum thickness of member, spacing and edge distance**

Anchor type		FIXPLUG 8, 10
minimum thickness of member	$h_{min}$ = [mm]	100
minimum spacing	$s_{min}$ = [mm]	100
minimal edge distance	$c_{min}$ = [mm]	100

Scheme of spacing and edge distances

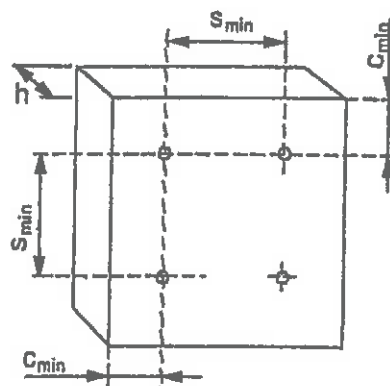

**FIXPLUG 8 and FIXPLUG 10**

**Intended use**  
Installation parameters  
Minimum thickness of member, edge distance and spacing

**Annex B 2**

### Installation instructions

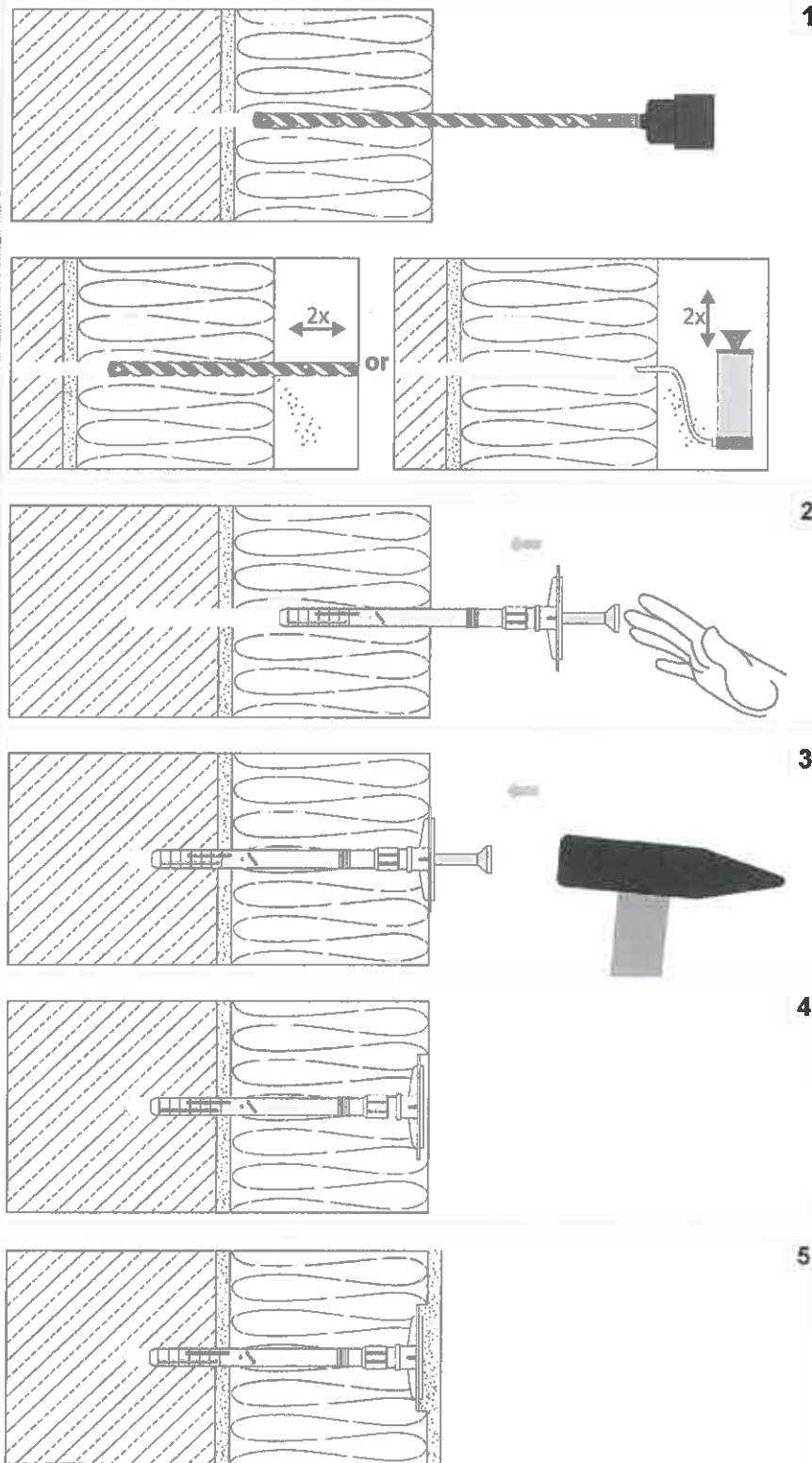

FIXPLUG 8 and FIXPLUG 10

Intended use  
Installation instructions

Annex B 3

**Table C1: Characteristic resistance to tension loads  $N_{Rk}$  for use in concrete and masonry for a single anchor**

Base material	Bulk density class [kg/dm <sup>3</sup> ]	Minimum compressive strength [N/mm <sup>2</sup> ]	General remarks	Drill method	Fixplug 8 $N_{Rk}$ [kN]	Fixplug 10 $N_{Rk}$ [kN]
Concrete C12/15 EN 206-1:2000	≥ 2.25	≥ 30		hammer	0,6	0,75
Concrete C16/20 - C50/60 EN 206-1:2000	≥ 2.30	≥ 65		hammer	0,9	1,2
Solid clay brick Mz e.g. according to EN 771-1:2011	≥ 2.0	≥ 20		hammer	0,9	0,9
Calcium silicate solid bricks KS e.g. according to EN 771-2:2011	≥ 2.0	≥ 20		hammer	0,9	0,9
Calcium silicate hollow block KSL e.g. according to EN 771-2:2011	≥ 1.6	≥ 12	Vertically perforation ≥15% and ≤50%	hammer	0,6 <sup>1)</sup>	0,6 <sup>1)</sup>
Vertically perforated clay bricks HLz) e.g. according to EN 771-1:2011	≥ 1.2	≥ 12	Vertically perforation ≥15% and ≤50%	rotary	0,4 <sup>2)</sup>	0,4 <sup>2)</sup>
Lightweight concrete hollow blocks HBL e.g according to EN 771-3:2011	≥ 0.8	≥ 2		rotary	0,75 <sup>3)</sup>	0,9 <sup>3)</sup>
Autoclaved aerated concrete AAC 2 e.g. according to EN 771-4:2011	≥ 0.35	≥ 2		rotary	0,5	0,5
Autoclaved aerated concrete AAC 7 e.g. according to EN 771-4:2011	≥ 0.65	≥ 3.5		rotary	0,75	0,75
Lightweight aggregate concrete LAC 5 – LAC 25 e.g. according to EN 1520:2011 / EN 771-3:2011	≥ 1.05	≥ 5		rotary	0,6	0,75

1) The value applies only for outer web thickness ≥ 20 mm; otherwise  $N_{Rk}$  shall be determined by job site tests.

2) The value applies only for outer web thickness ≥ 17 mm; otherwise  $N_{Rk}$  shall be determined by job site tests.

3) The value applies only for outer web thickness ≥ 32 mm; otherwise  $N_{Rk}$  shall be determined by job site tests.

**FIXPLUG 8 and FIXPLUG 10**

**Performances**  
Characteristic resistance

**Annex C 1**

**Table C2: Point thermal transmittance according EOTA Technical Report TR 025:2007-06**

Anchor type	Insulation thickness $t_{fix}$ [mm]	point thermal transmittance $\chi$ [W/K]
FIXPLUG 8	110-210	0
FIXPLUG 10	120-260	0

**Table C3: Plate stiffness according EOTA Technical Report TR 026:2007-06**

Anchor type	Diameter of the anchor plate [mm]	Load resistance of the anchor plate [kN]	Plate stiffness [kN/mm]
FIXPLUG 8	60	1,4	0,6
FIXPLUG 10	60	1,6	0,6

**Table C4: Displacements**

Base material	Bulk density class [kg/dm <sup>3</sup> ]	Minimum compressive strength [N/mm <sup>2</sup> ]	Tension load N [kN]		Displacements $\delta_m(N)$ [mm]	
			FIXPLUG 8	FIXPLUG 10	FIXPLUG 8	FIXPLUG 10
Concrete C12/15	≥ 2.25	≥ 30	0,2	0,25	0,45	0,46
Concrete C16/20 - C50/60	≥ 2.30	≥ 65	0,3	0,4	0,63	0,74
Solid clay brick Mz	≥ 2.0	≥ 20	0,3	0,3	0,73	0,78
Calcium silicate bricks KS	≥ 2.0	≥ 20	0,3	0,3	0,74	0,90
Calcium silicate hollow block KSL	≥ 1.6	≥ 12	0,2	0,2	0,66	0,64
Vertically perforated clay bricks HLz	≥ 1.2	≥ 12	0,13	0,13	0,84	0,79
Lightweight concrete hollow blocks HBL	≥ 0.8	≥ 2	0,25	0,3	0,81	0,75
Autoclaved aerated concrete AAC 2	≥ 0.35	≥ 2	0,17	0,17	0,42	0,57
Autoclaved aerated concrete AAC 7	≥ 0.65	≥ 3.5	0,25	0,25	0,76	0,87
Lightweight aggregate concrete LAC 5-25	≥ 1.05	≥ 5	0,2	0,25	0,80	0,84

**FIXPLUG 8 and FIXPLUG 10**

**Performances**

Point thermal transmittance, plate stiffness, displacements

**Annex C 2**