

SWE	MONTERINGSANVISNING
GBR	MOUNTING INSTRUCTIONS
DEN	MONTERINGSANVISNING
NOR	MONTERINGSANVISNING
FIN	YKSIOTEHANOJEN ASENNUSOHJE
EST	PAIGALDUSJUHEND
LAT	UZSTĀDĪŠANAS INSTRUKCIJA
LTU	MONTAVIMO INSTRUKCIJA
UKR	ІНСТРУКЦІЯ З МОНТАЖУ
CZE	MONTÁŽNÍ NÁVOD BATERIE
SVK	MONTÁŽNY NÁVOD BATÉRIE
ROU	INSTRUCȚIUNI DE MONTARE

GUSTAVSBERG /
SMARTER BATHROOMS



SINCE 1825



EPIC

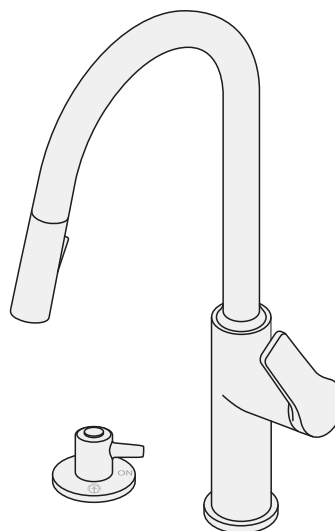
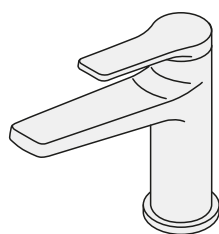
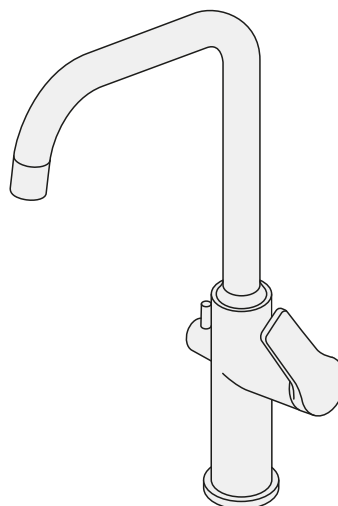
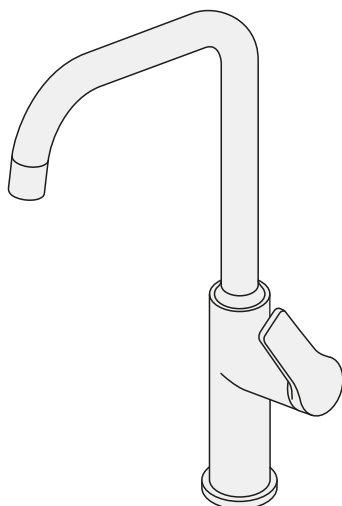

Accepterad
monteringsanvisning
2021:1

				3/16
		Tekniska data Technical data.		4/16
				5/16
				6-7/16
				8-9/16
				10/16
				11/16
				11/16
		Rengöring Clean Rengøring Rengjöring Puhdistus очистка	Puhastamine Tīršana Švarus Очищення Čistý	12/16
		Skötsel Maintenance Beskyttelse Vedlikehold Hoito-ohje Уход	Hooldus Kopšanas informācija Montavimas Догляд Péče o baterii Starostlivosť o batériu	12/16
				13-15/16
		Reservdelar Spare parts Reservdeler Reservedele Varaosat	Varuosad Atsarginės dalys Rezerwes części Запасные части	16/16

SE GARANTI

Produkten har garanti enligt respektive lands gällande branschvillkor.

Direktiv vid reklamation

Våra produkter är tillverkade enligt väldigt stränga kvalitetskrav. Om en produkt trots det är felaktig, ber vi er i första hand att kontakta din återförsäljare. Ärendet underlättas genom att uppvisa kvitto och uppge produktnummer och inköpsdatum.

DK GARANTI

Produktet har garanti i forhold til gældende dansk lovgivning.

Vejledning ved reklamation

Vores produkter er fremstillet i overensstemmelse med markedets strengeste krav til kvalitet. Skulle produktet mod forventning være behæftet med fejl henviser vi til den forhandler, hvor produktet er købt. Kvittering skal kunne fremvises, hvis forhandleren forlanger det, ligesom oplysninger om produktnummer og købsdato skal kunne dokumenteres.

NO GARANTI

Produktene har garanti i henhold til respektive lands gjeldende bransjevilkår.

Instrukser ved reklamasjon

Våre produkter er produsert i henhold til veldig strenge kvalitetskrav. Om et produkt til tross for dette skulle være feilaktig, ber vi deg vennligst ta kontakt med forhandleren. Vi ber deg medbringe kvittering og oppgi innkjøpsdato samt produktnummer.

FI TAKUU

Noudatamme alamme yleisiä toimitusehtoja.

Reklamaatio

Tuotteemme ovat valmistettu Villeroy & Boch in ja Gustavsbergin laatuvaatimuksien mukaisesti. Mikäli tuote kuitenkin on virheellinen pyydämme teitä kääntymään ensisijaisesti tuotteen myyjän puoleen. Käsitteilyn helpottamiseksi säilyttäkää tosite tuotteen ostosta.

GB GUARANTEE

The product has a guarantee accordingly to industry rules in every country.

Instructions for complaints

Our products are made according to very strict quality demands. If the product is faulty in spite of that we ask you kindly to take it to your retailer. We also ask you to bring the receipt and be prepared to inform about the product number and purchasing date.

EE GARANTII

Antud tootel on garantii vastavalt tehase poolt kehtestatud tingimustele.

Juhised reklamatsioonide käsitlemiseks

Meie tooted on valmistatud silmas pidades väga täpseid kvaliteedistandardeid. Juhul kui olete saanud praaktoote, palume Teil toimetada see kas meie edasimüüja juurde või võtta ühendust esindusega. Samuti palume alles hoida ostutšekk ning vajadusel anda informatsiooni tootenumbri ja ostu sooritamise aja kohta.

LV GARANTIJA

Izstrādājumam ir garantija saskaņā ar ražotāja standartiem.

Instrukcija kvalitātes problēmu gadījumā

Mūsu produkcija tiek ražota pēc ļoti striktiem kvalitātes kritērijiem. Taču – gadījumā, ja produktam tiek konstatēta kvalitātes problēma – lūdzam, sazinieties ar pārdevēju. Lūdzam, esiet gatavi arī uzrādīt pirkuma čeku ar pirkuma datumu.

LT GARANTIJA

Gaminiams garantija suteikiama atsižvelgiant į konkrečios šalies kokybės reikalavimus.

Reklamacijos

Mūsų produkcija pagaminta vadovaujantis griežtais kokybės reikalavimais. Jei gaminys nekokybiškas – prašome jį grąžinti pardavėjui, pateikiant pirkimo čekį, gaminio numerį bei nurodant pirkimo datą.

ГАРАНТІЯ

Ця продукція підтримується гарантією у відповідності з правилами та законами, що діють у країні збуту.

Рекламації

Наша продукція відповідає сучасним стандартам та вимогам щодо якості. У випадку виникнення несправності, Ви можете звернутися в торгову організацію, де був придбаний цей виріб. Для оформлення рекламації необхідно додати супровідні документи щодо виробу та чек, що підтверджує найменування та дату покупки

RU ГАРАНТИЯ

Гарантийные условия устанавливаются в соответствии с законами и правилами, которые действуют в стране сбыта.

Рассмотрение рекламаций

Наша продукция соответствует современным стандартам и требованиям к качеству. В случае возникновения неисправности Вы можете обратиться в торговую организацию, где было приобретено данное изделие. При заявлении рекламации необходимо предъявить сопроводительные документы к данной продукции и чек, подтверждающий дату покупки.

GARANTII

Antud tootele kehtivad garantiitingimused tulenevad kohalikest õigusaktidest.

Juhised reklamatsioonide käsitlemiseks

Meie tooted on valmistatud silmas pidades väga täpseid kvaliteedistandardeid. Juhul kui olete saanud praaktoote, palume Teil toimetada see kas meie edasimüüja juurde või võtta ühendust esindusega. Samuti palume alles hoida ostutšekk ning vajadusel anda informatsiooni tootenumbri ja ostu sooritamise aja kohta.

GARANTIJA

Produktam ir garantija atbilstoši nozares noteikumiem konkrētajā valstī.

nstrukcijas sūdzību pieteikšanai

Mūsu produkti ir izgatavoti saskaņā ar ļoti stingriem kvalitātes prasībām. Tomēr, ja produkts ir bojāts, mēs lūdzam griezties produkta iegādes vietā. Mēs lūdzam arī sagatavot uzrādīšanai pirkuma čeku un informāciju par pirkuma datumu.

GARANTIJA

Gaminiams garantija suteikiama atsižvelgiant į konkrečios šalies kokybes reikalavimus.

Pretenzijos

Mūsų produkcija pagaminta vadovaujantis griežtais kokybes reikalavimais. Jei gaminys nekokybiškas – prašome jį grąžinti pardavėjui, pateikiant pirkimo čekį, bei nurodyti pirkimo datą

TEKNISK DATA / TECHNICAL DATA



Artnr/Art no	RSK no
GB41219951	8278218
GB41219951 24	8278219
GB41219951 53	8278220

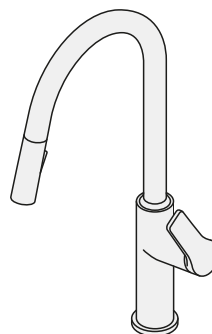

Artnr/Art no	RSK no
GB41209959	8311192
GB41209959 24	8311193
GB41209959 53	8311194

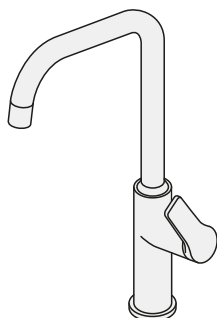

Artnr/Art no	RSK no
GB41209956	8311186
GB41209956 24	8311187
GB41209956 53	8311188

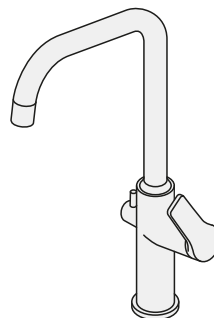

Artnr/Art no	RSK no
GB41209996	8311189
GB41209996 24	8311190
GB41209996 53	8311191



Artnr/Art no	RSK no
GB41639755	8394058
GB41639755 24	8394059
GB41639755 53	8394060

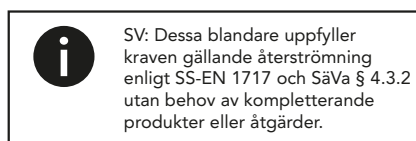

C900341, C900342, C900043, C900343

Standard / Standard	EN 817
Drifttryck / Working pressure	50-1000 kPA
Provningstryck max / Testpressure max	1600 kPA
Max varmvattentemperatur / Max. hot water temperature	70° C
Rekommenderad varmvattentemp. / Recommended hot water temp.	60° C
Kallvattentemperatur / Cold water	10° C
Anslutning / Connection	G3/8. Flexible Pex®
Återströmningsskydd / Backflow preventer	AA
Desinfektion / Thermal disinfection	70° C. 4 minutes



EPIC

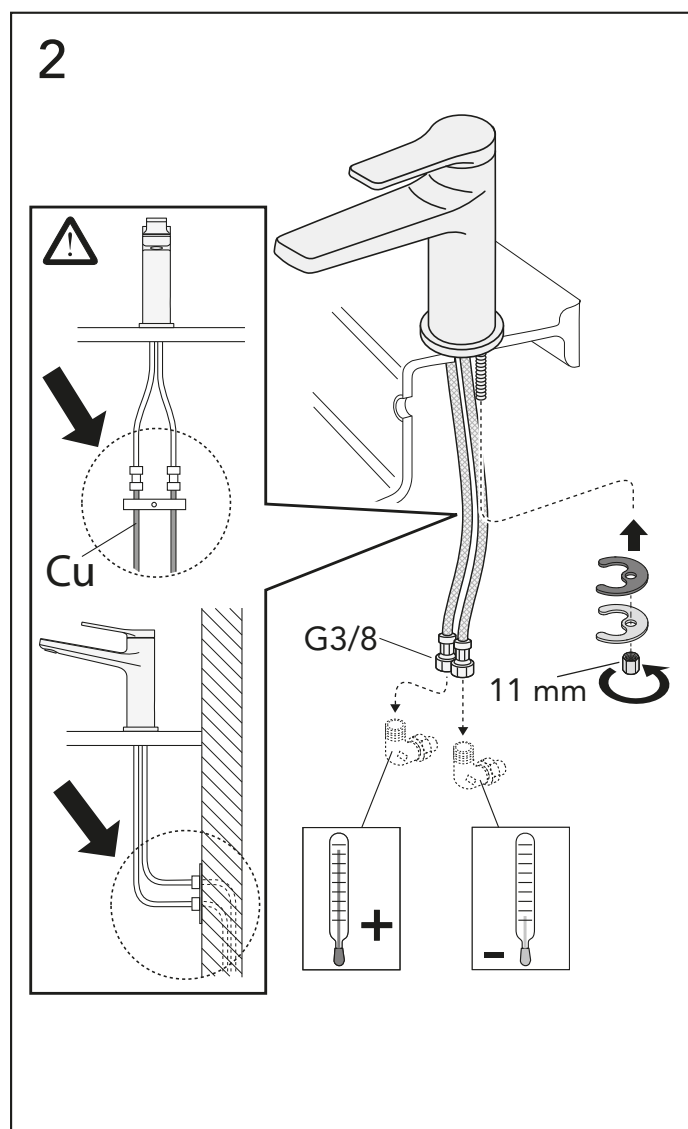
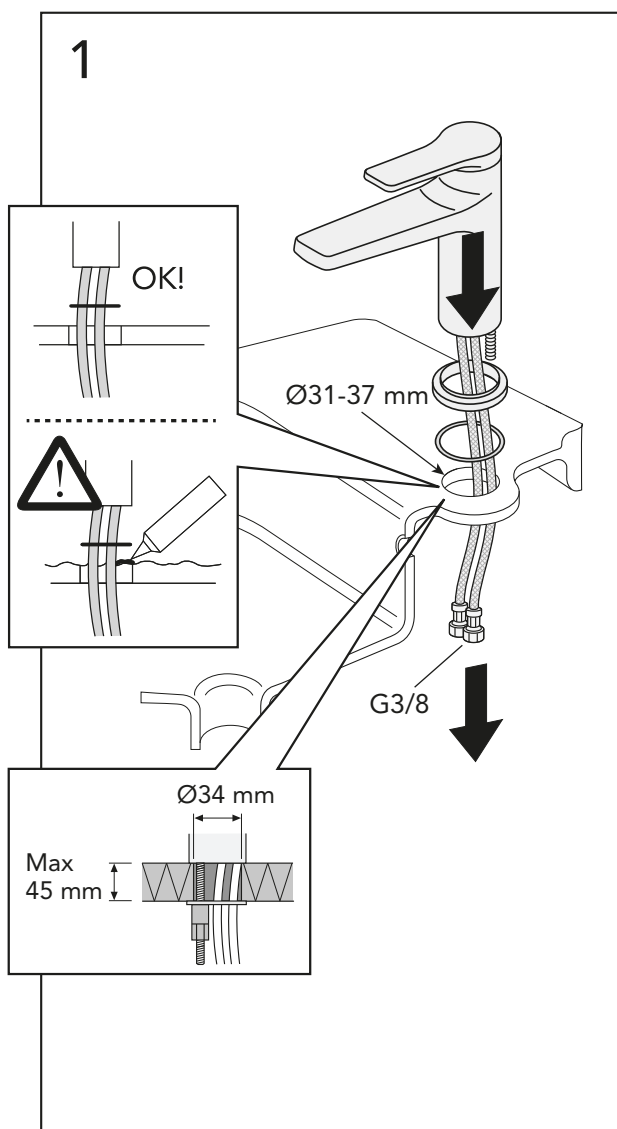



EPIC

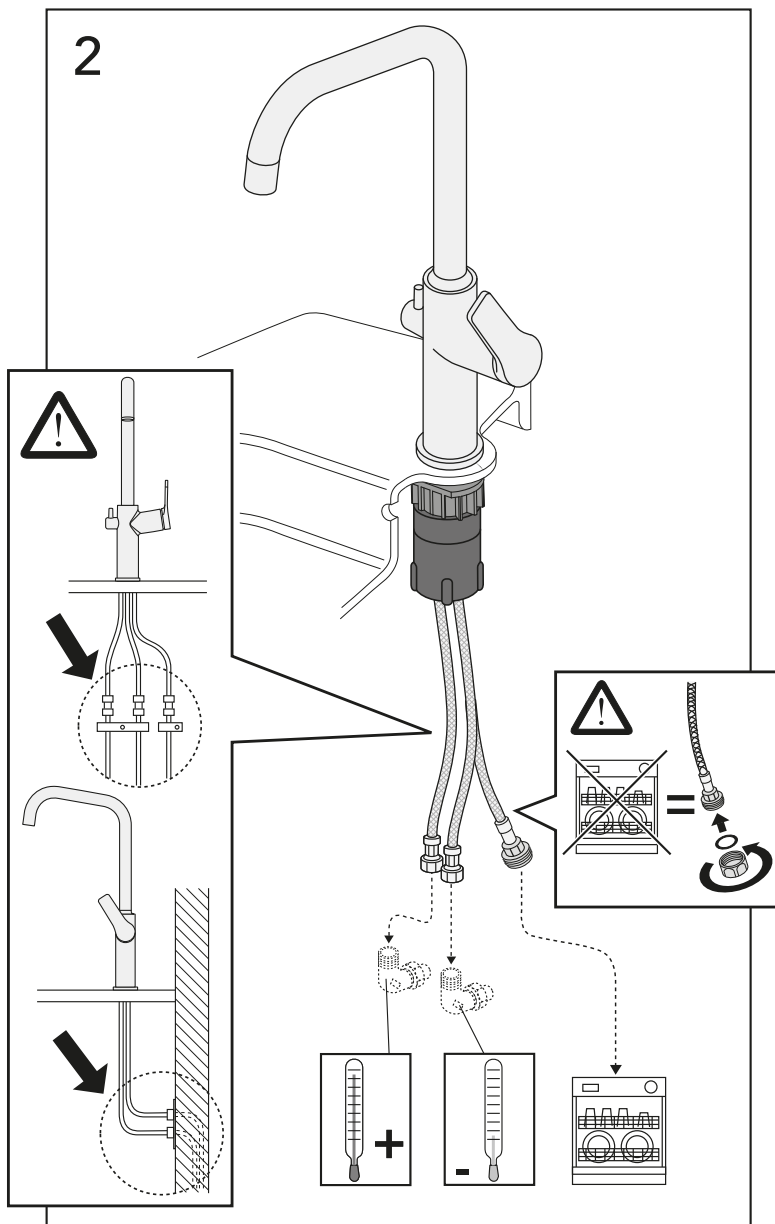
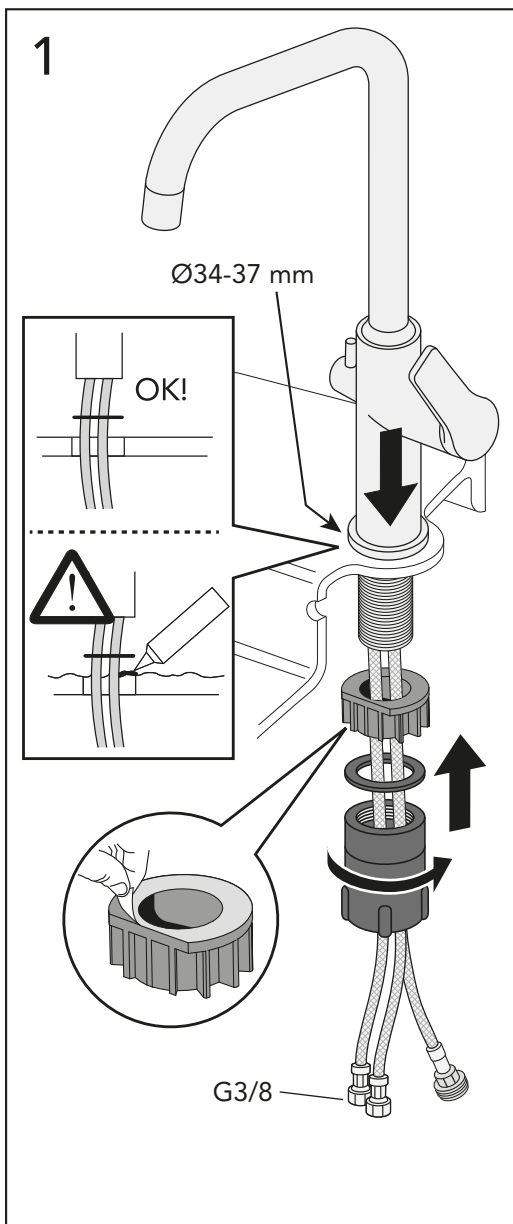



EPIC PULL OUT

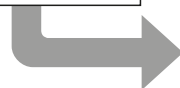
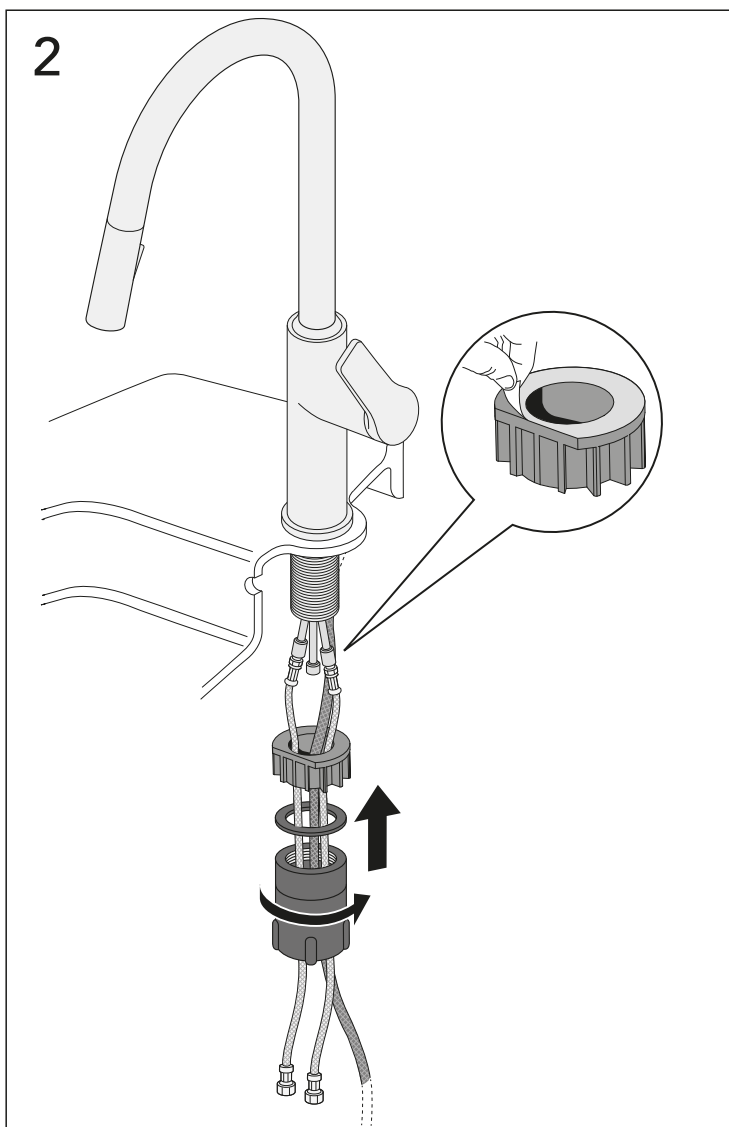
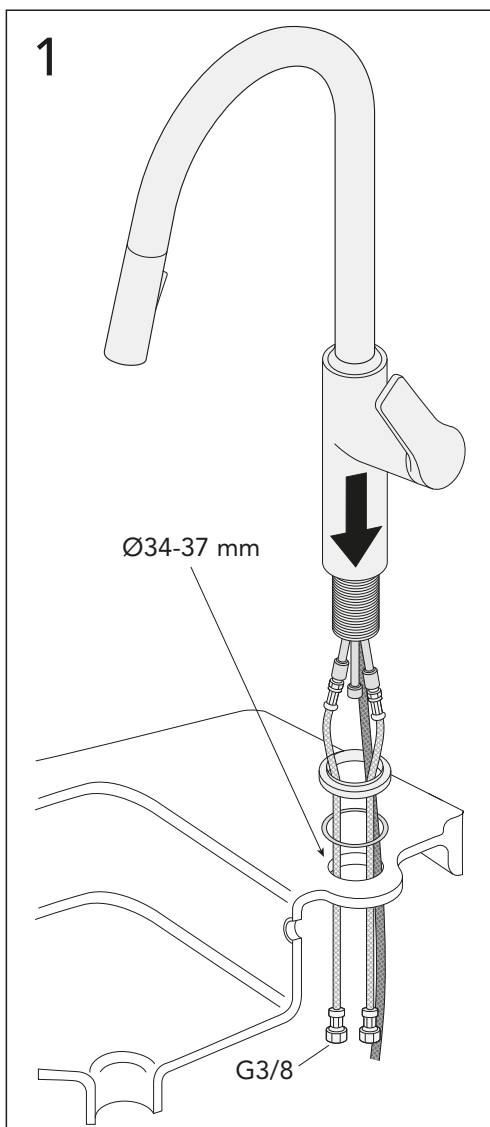
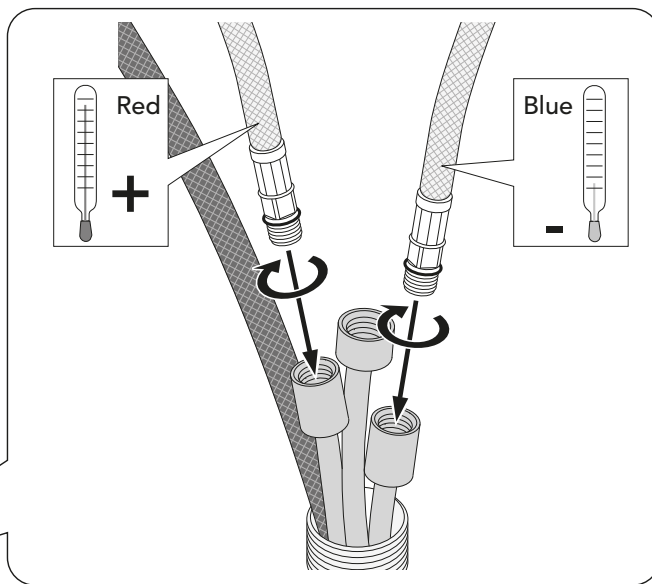
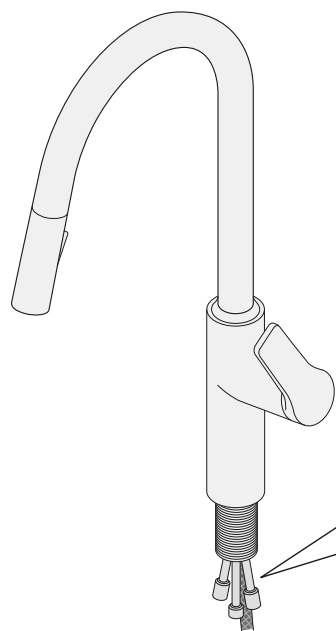

3

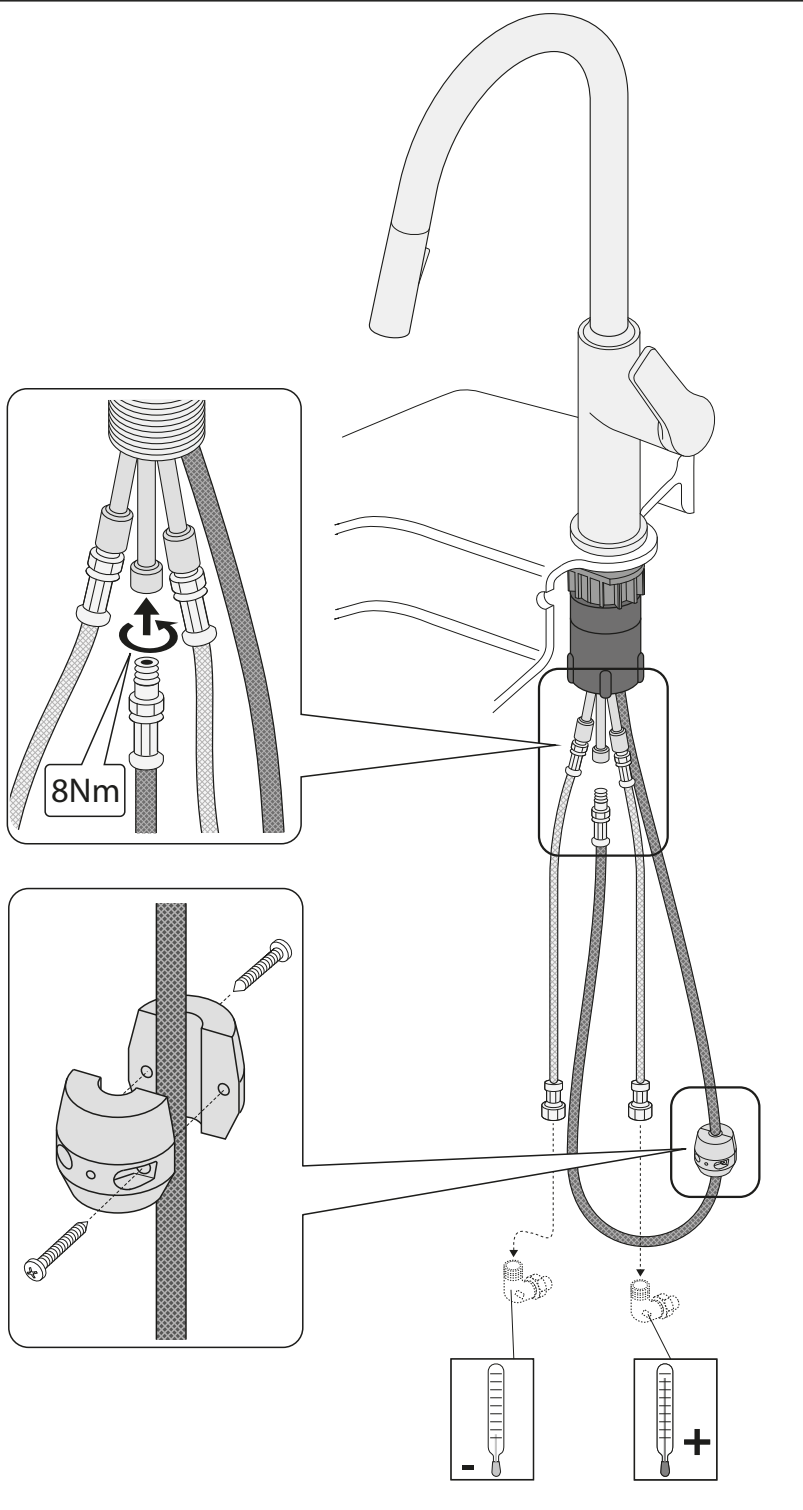



EPIC

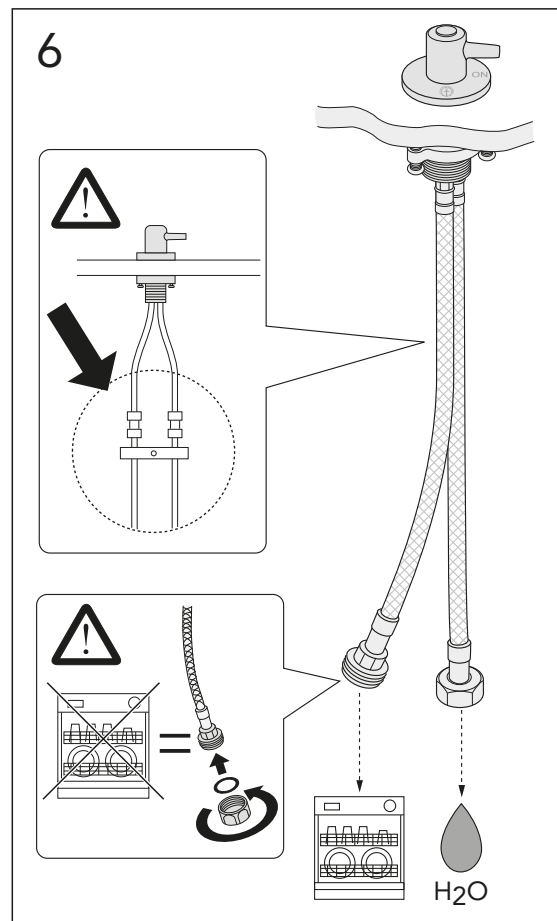
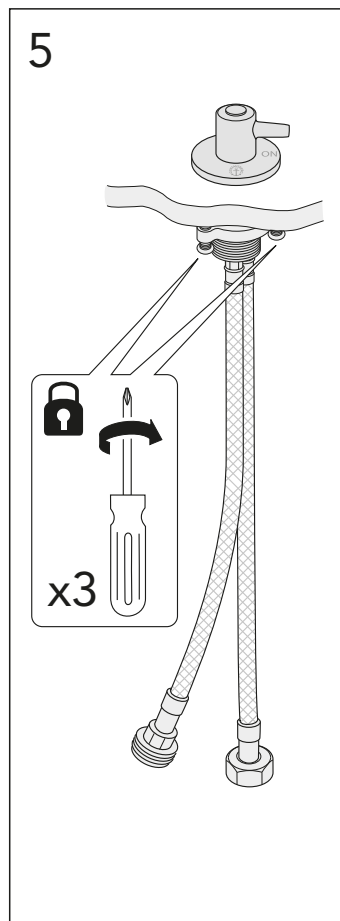
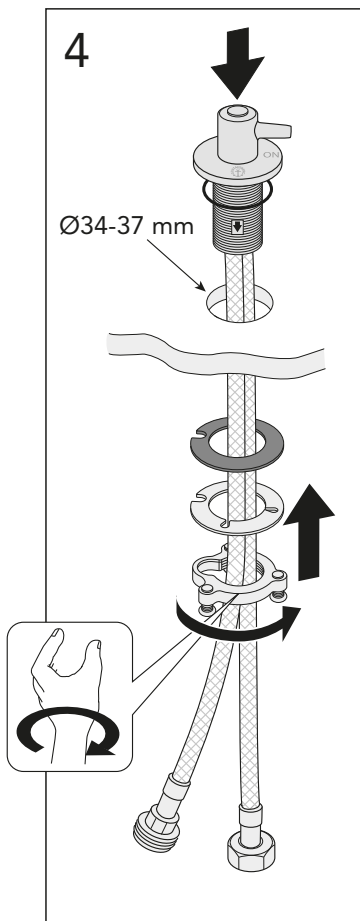
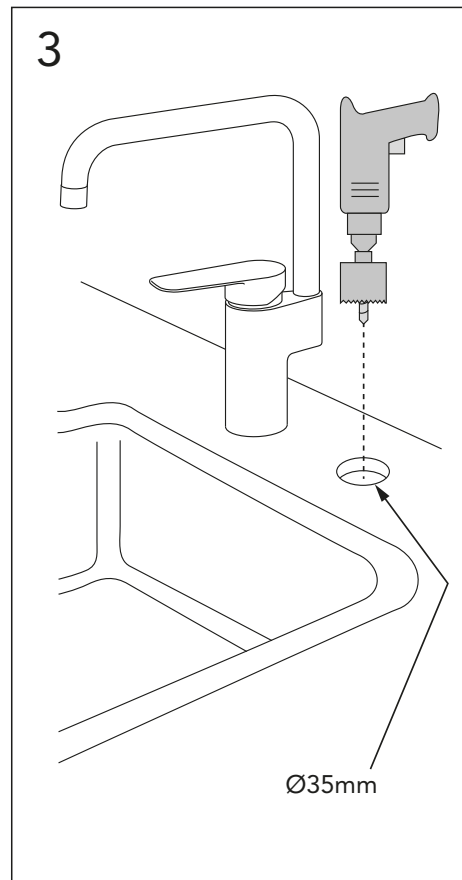
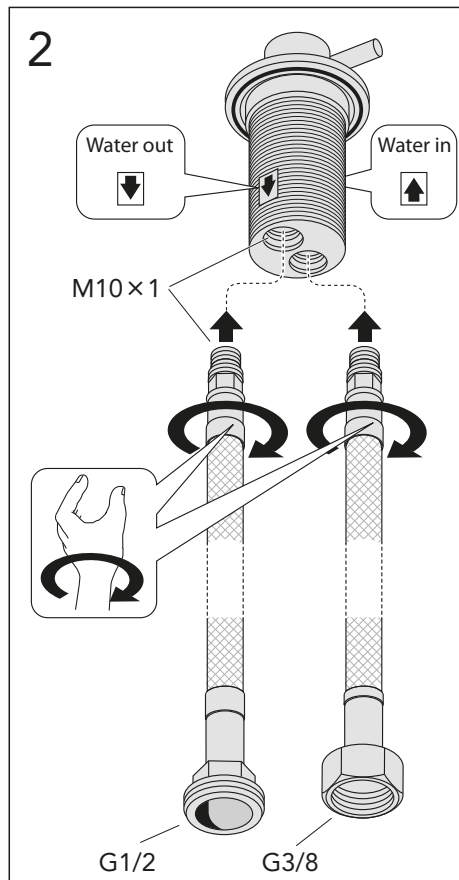
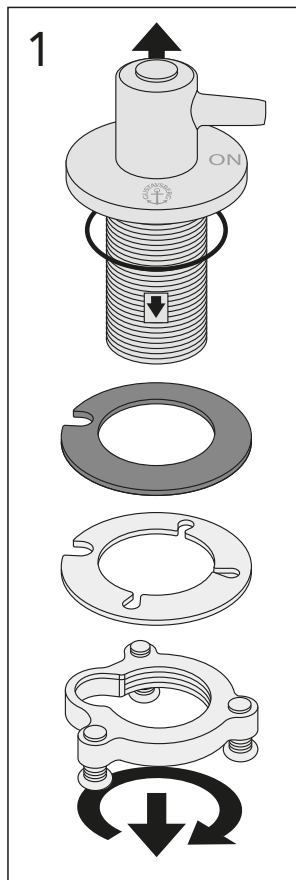

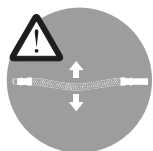

SOFTPEX

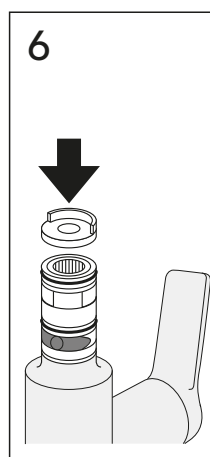
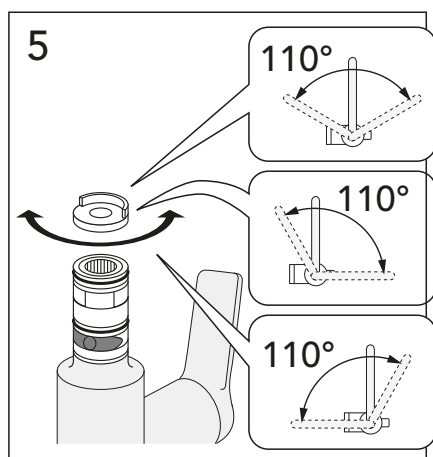
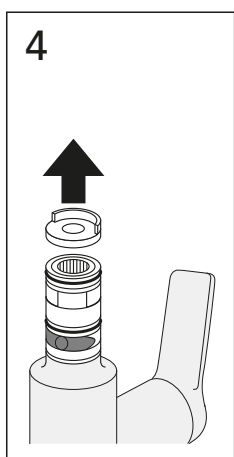
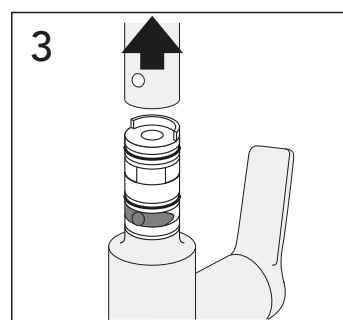
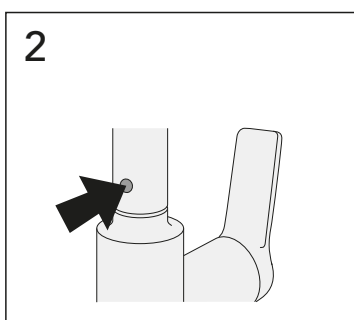
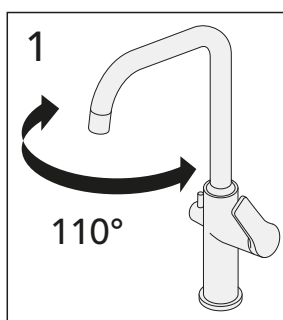
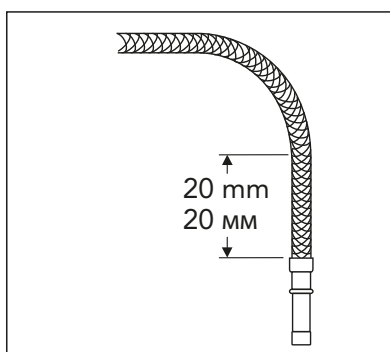
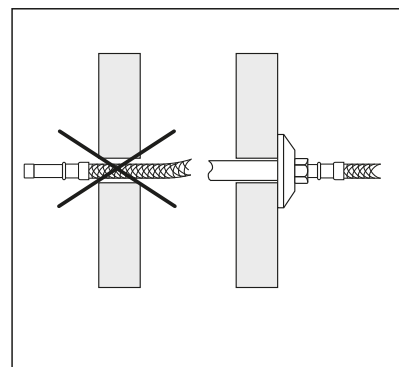
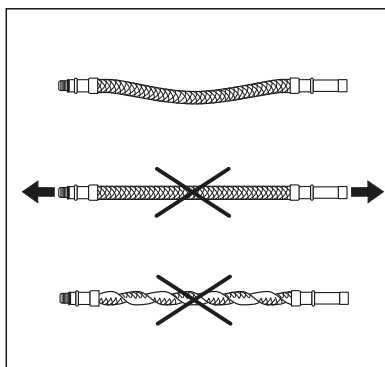
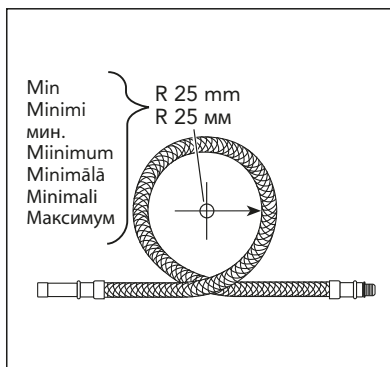

Klick
Klik
клик
Užfiksuoti
Клацання
Свак

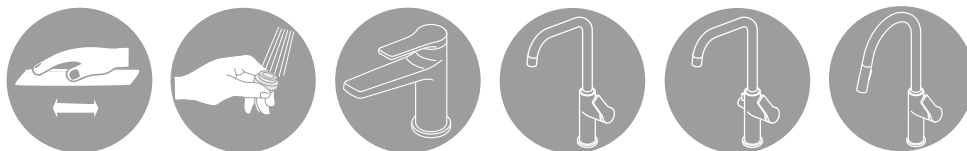

Rengöring
Clean
Rengjøring
Puhdistus
очистка

Puhastamine
Tirišana
Švarus
Очищення
Čistý

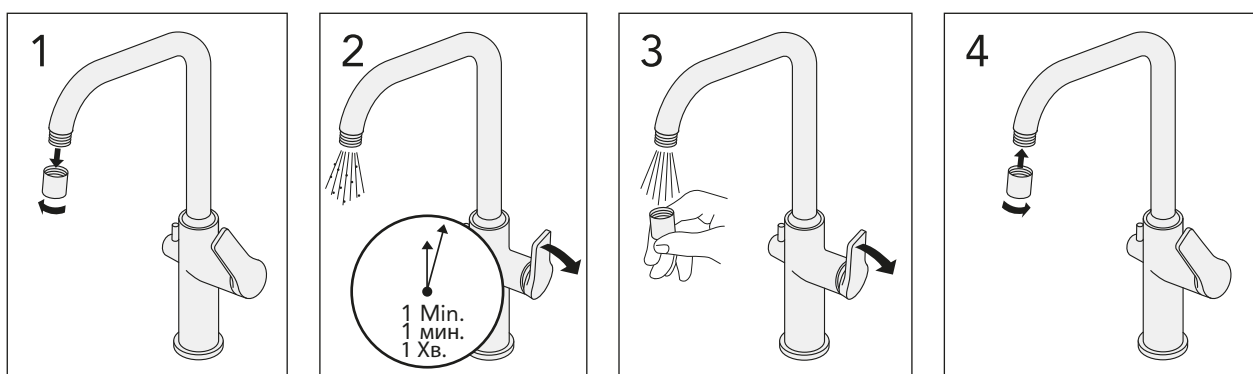
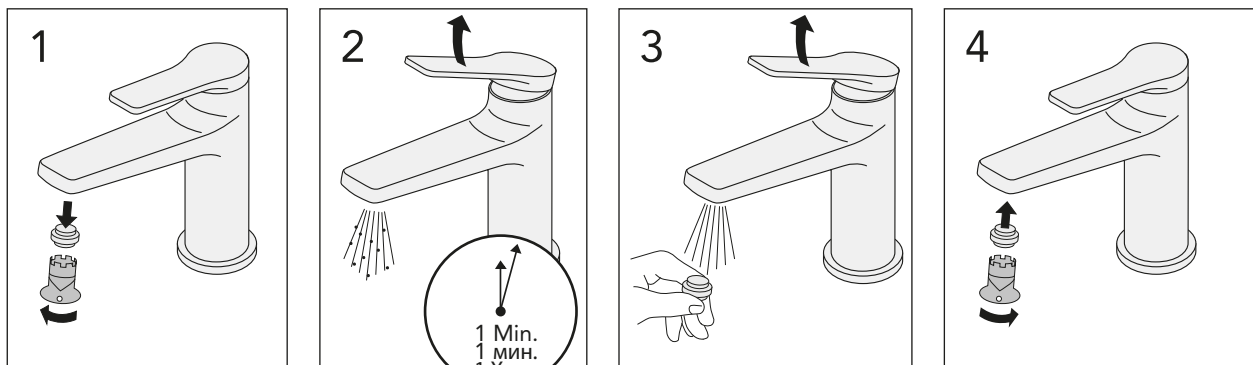

Skötsel
Maintenance
Beskyttelse
Vedlikehold
Hoito-ohje
Уход

Hooldus
Kopšanas informācija
Montavimas
Догляд
Рѣче о батэриі
Starostlivosť o batériu

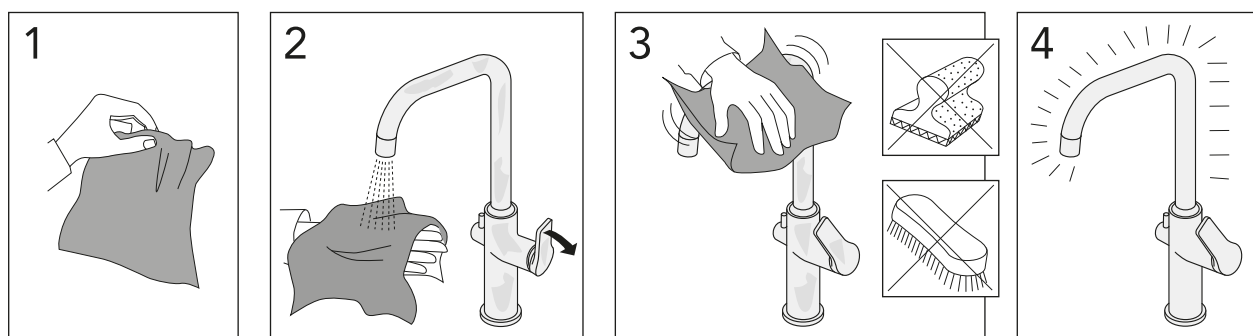
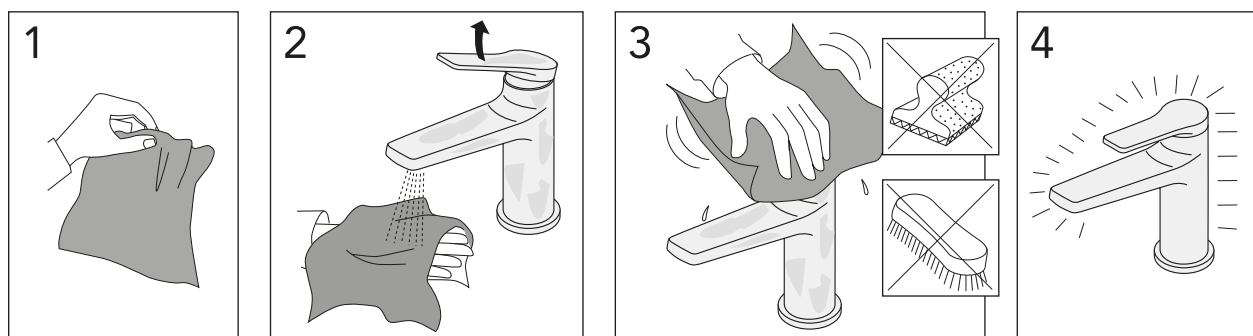

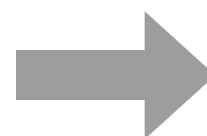
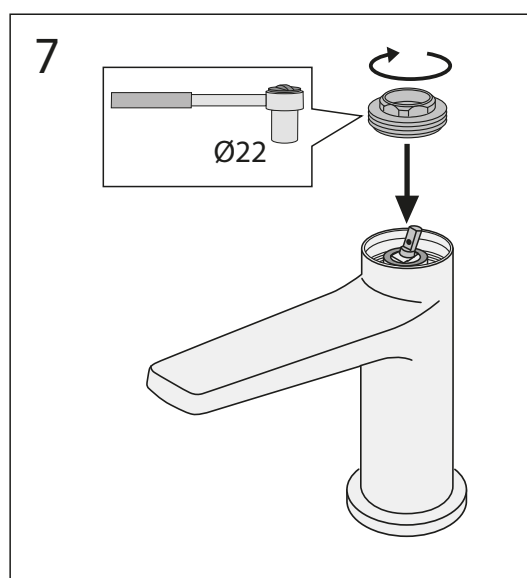
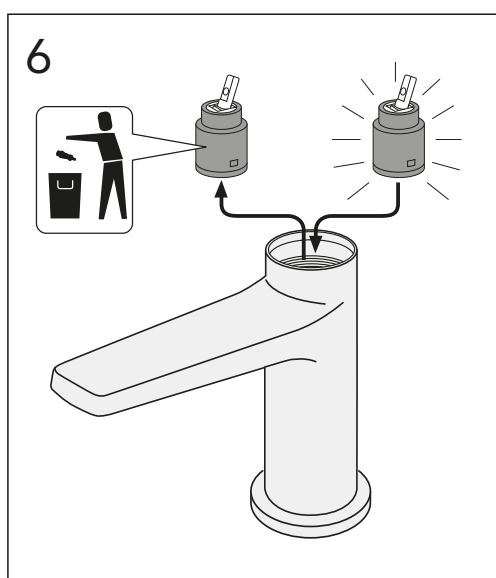
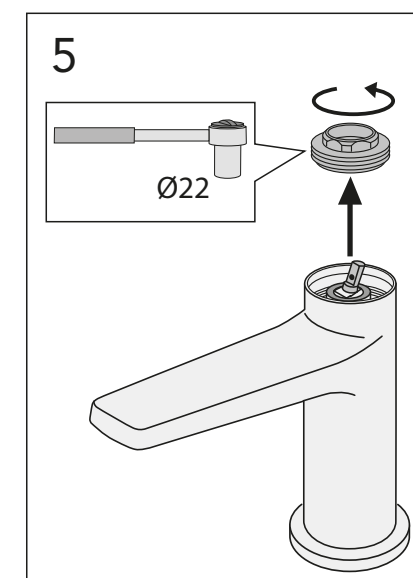
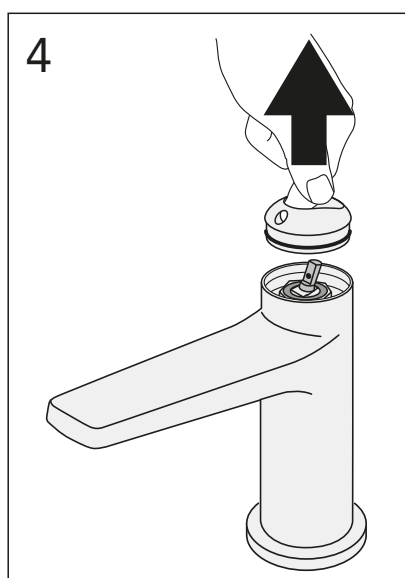
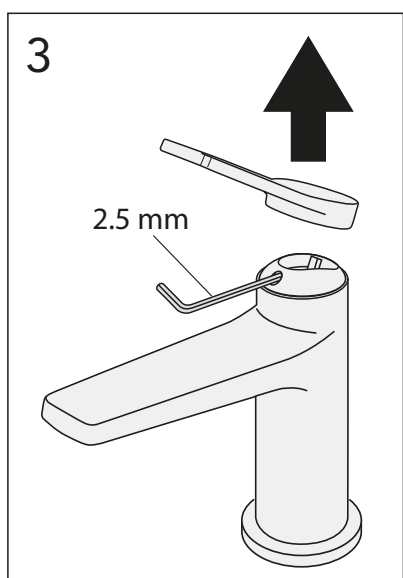
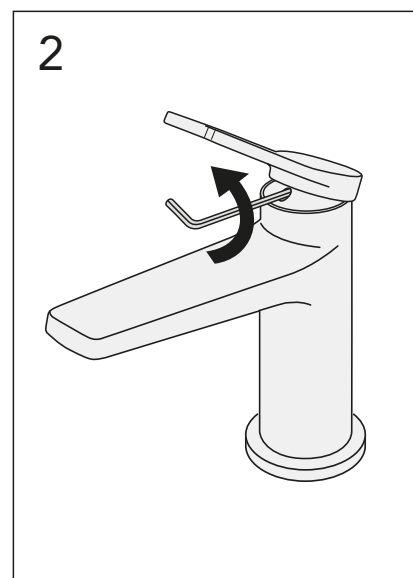
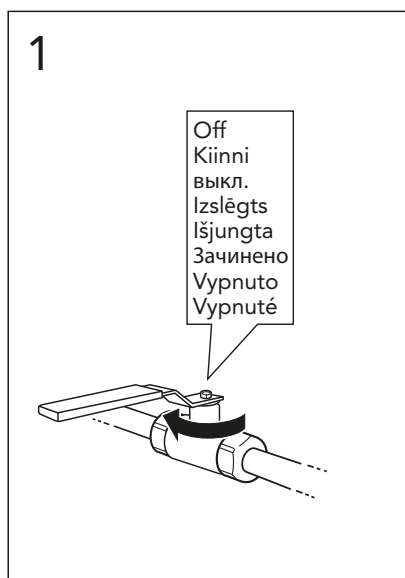
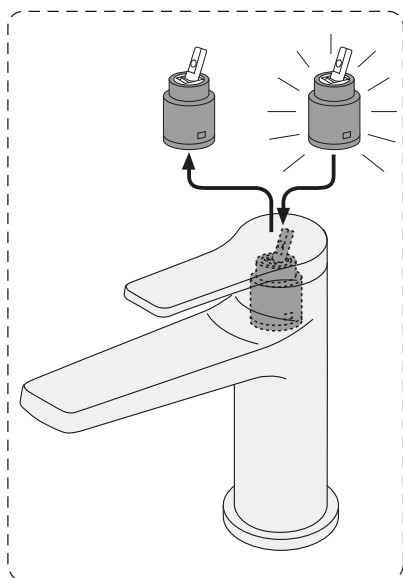

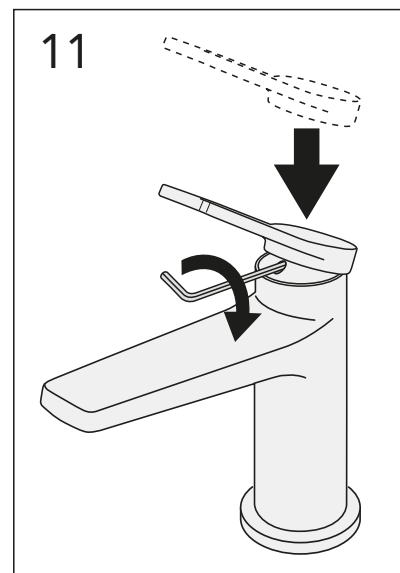
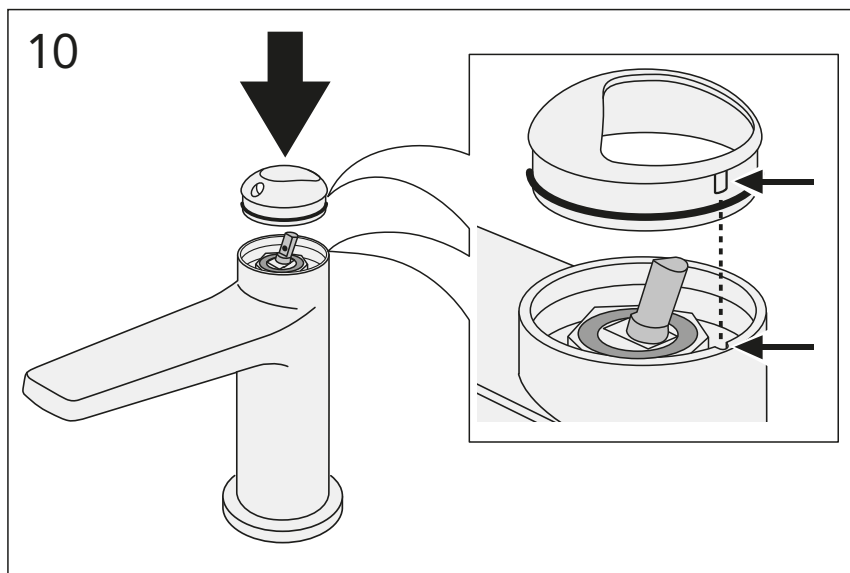
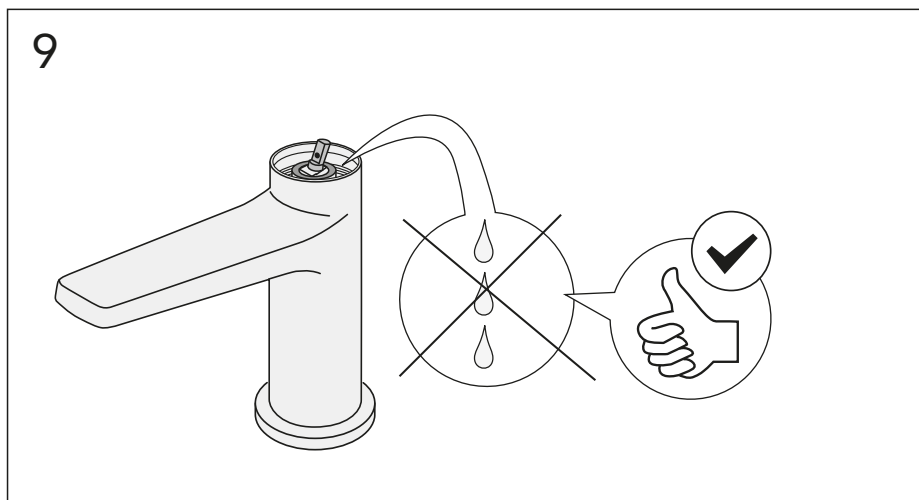
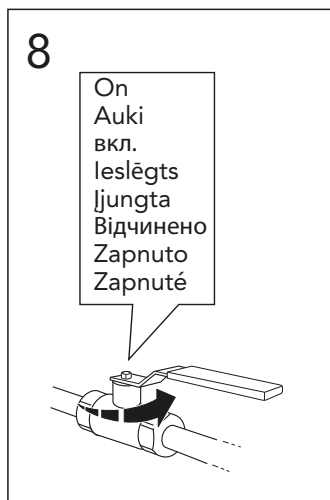

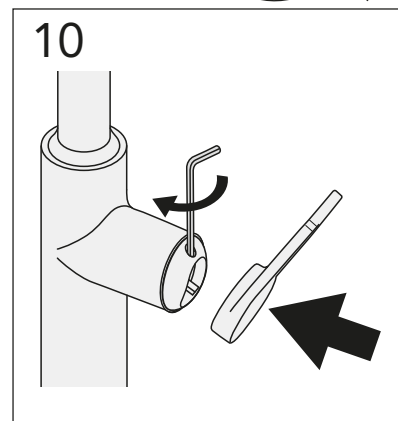
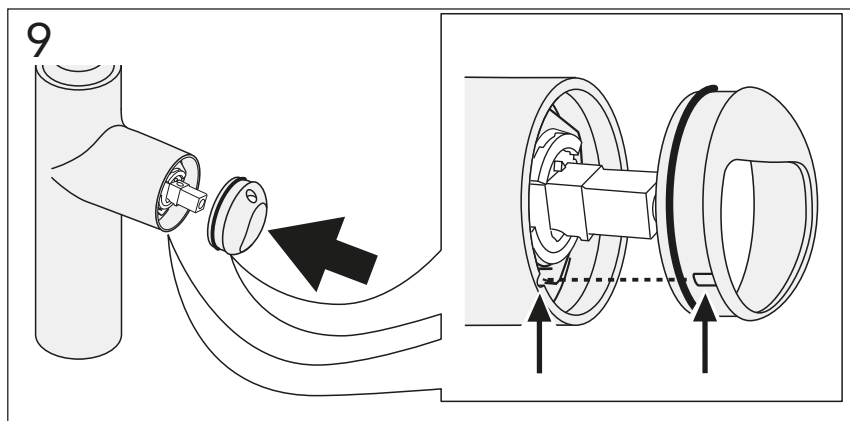
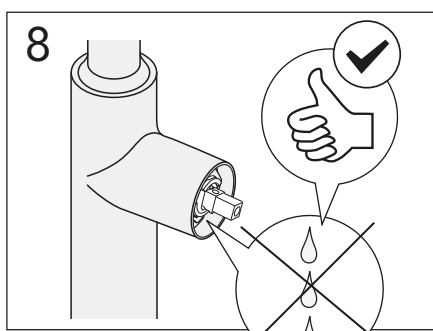
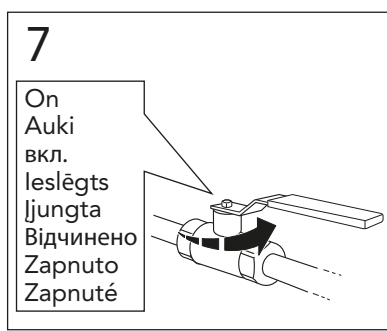
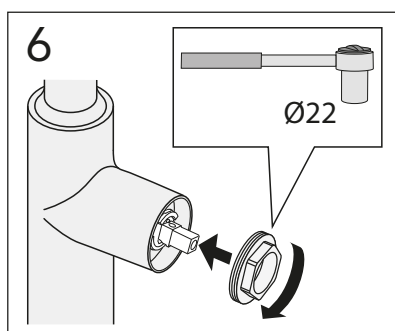
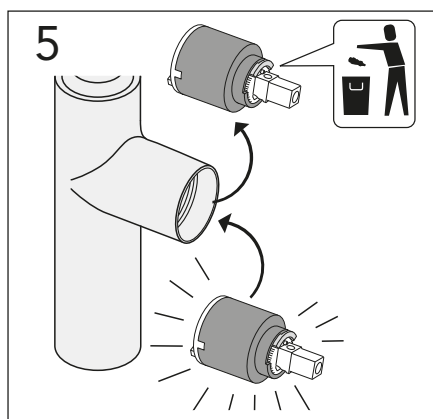
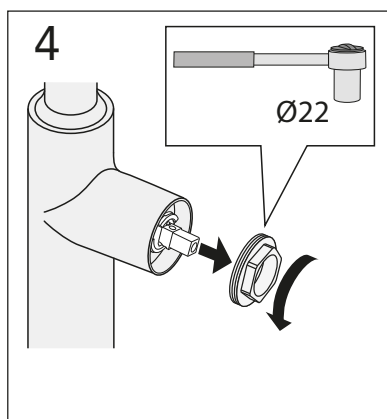
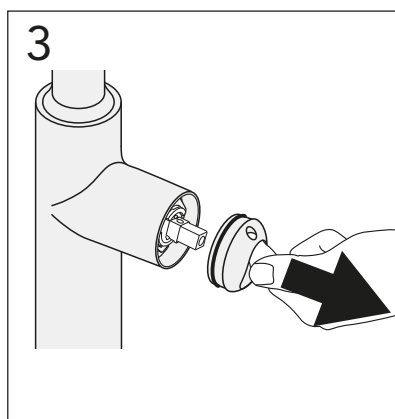
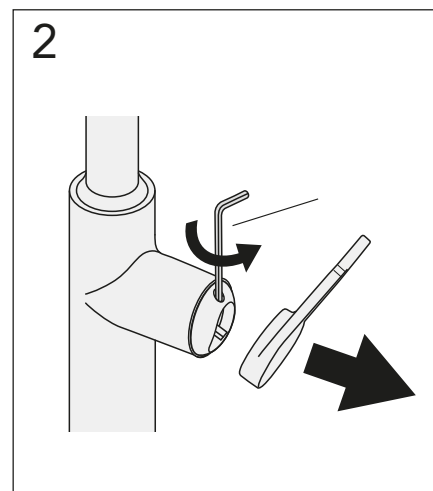
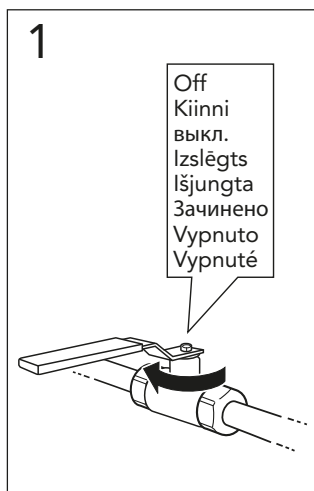
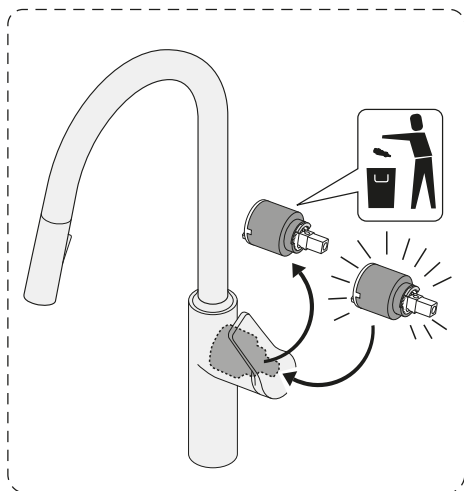



EPIC

Reservdelar
Reservedeler
Reservevele
Varaosat
Spare parts
Varuosad
Atsarginės dalys
Rezerves Dajās
ЗАПАСНЫЕ ЧАСТИ



DETLJÄMME OCH PRODUKT	BESKRIVNING	PRIS (inkl. moms och skatt)	RSK-NUMMER	ARTIKELNUMMER
1 Sittare Epic	Mixing handle	15 300,00 (17 070,00)	04184	117304184
2 Spak Epic	Spoke	304,00	03402	034020300
3 Spak Epic	Spoke	304,00	03402	034020300
4 Spak Epic	Spoke	304,00	03402	034020300
5 Föring 899 Epic	Spoke	312,00	03402	034020300
6 Carnio 822 Epic	Mixer handle	401,00	03402	034020300
7 Föring 816 Epic	Mixer handle	304,00	03402	034020300
8 Föring 822 Epic	Mixer handle	401,00	03402	034020300

www.gustavsberg.com



A MEMBER OF THE
VILLEROY & BOCH GROUP

Sweden
www.gustavsberg.com/se/

Denmark
www.gustavsberg.com/dk/

Norway
www.gustavsberg.com/no/

Suomi/Finland
www.gustavsberg.com/fi/

Estonia
www.gustavsberg.com/ee/

Latvia
www.gustavsberg.com/lv/

Lithuania
www.gustavsberg.com/lt/

Україна
www.gustavsberg.com/ua/

Россия
www.gustavsberg.com/ru/