

VEXVE

Steel ball valves
installation, operation and maintenance manual

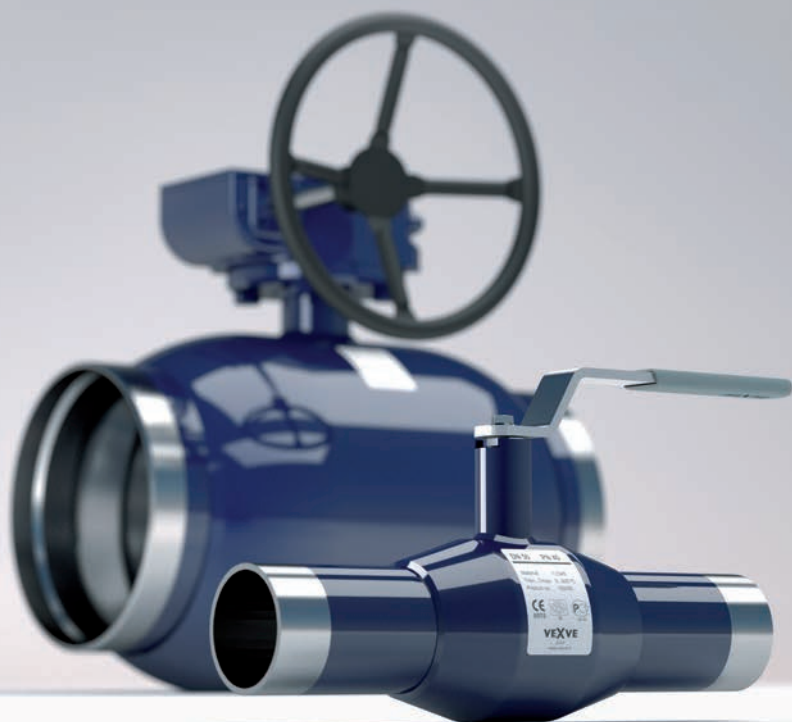

Contents

1. General	4
2. Valve identification	5
3. Unloading and storage	6
4. Valve installation	8
4.1 Installation of valve with weld connections	9
4.1.1 Steel ball valves < DN300 reduced bore	9
4.1.2 Steel ball valves ≥ DN300 reduced bore	10
4.2 Installation of valve with flanges	11
4.3 Installation at the end of pipeline	12
4.4 Before commissioning	13
4.5 Commissioning and Pressure testing	13
5. Gear and actuator disassembly and installation	14
5.1 Disassembly and reinstallation of ProGear/Rotork manual gear	14
5.2 Adjustment of ProGear/Rotork manual gear	15
5.3 Disassembly and reinstallation of AUMA electric actuator	16
5.4 Adjustment of the mechanical limits of AUMA electric actuator	17
5.3 Assembly/disassembly of pneumatic actuator	18
5.4 Assembly/disassembly of hydraulic actuator	18
6. Maintenance	19
6.1 Replacing the O-ring seal of stem in valves DN10–DN50	20
6.2 Replacing the O-ring seal of stem in valves DN65–DN150	21
6.3 Replacing the O-ring seal of stem in valves with actuators DN65–DN150	22
6.4 Replacing the O-ring seal of stem in valves DN200–DN300	23
6.5 Replacing the O-ring seal of stem in valves DN350–DN800	24
7. Appendices	26
7.1 Parts list for steel ball valves < DN200	26
7.2 Parts list for steel ball valves ≥ DN200	27
7.3 Type code	28
7.4 Coupling dimensions, reduced bore ball valves DN15–800 with actuators	30
7.5 Coupling dimensions, full bore ball valves DN10–800 with actuators	31



NOTE:

This manual must be read and its instructions must be followed when installing, operating and/or performing maintenance on the valve as well as its manual gear or actuator.

These instructions are of general nature and do not cover all possible operating scenarios. For more specific guidance on the installation, operation and maintenance of the valve or its suitability for an intended use, please contact the manufacturer.

Vexve Oy reserves the right to make alterations to these instructions.

Vexve Oy is not responsible for damages caused by incorrect transportation, handling, installation, operation or maintenance. Furthermore, Vexve Oy is not responsible for damage caused by foreign objects or impurities.

Warranty

Warranty according to Vexve Oy's "General terms and conditions of sale".

The warranty covers manufacturing and material faults. The warranty does not apply to damages caused by inappropriate installation, operation, maintenance, or storage ie. these instructions must be followed for the warranty to apply. Vexve Oy requires that any faulty products under warranty are to be returned to the factory for inspection. Only after the product has been found faulty, Vexve Oy can grant compensation.

Please refer to Vexve Oy's "General terms and conditions of sale" for detailed warranty clauses. The document is available from the manufacturer

Warnings and symbols

Ignoring the warnings and symbols may lead to serious injury or equipment damage. Persons authorized to use the equipment must be familiar with the warnings and instructions.

Appropriate transportation, storage and installation as well as careful commissioning are essential to ensure faultless and stable operation.

The following symbols are used in this manual to draw attention to actions essential to ensure the proper use and safety of the device.



Meaning of the symbol: NOTE

The NOTE symbol is used for actions and functions that are essential for the proper use of the device. Ignoring this symbol may have harmful consequences.



Meaning of the symbol: WARNING

The WARNING symbol is used for actions and functions that, if carried out incorrectly, may lead to injury or equipment damage.

1. General

Vexve's fully welded steel ball valve (colour blue) is designed for clean mediums and to be used in district heating and district cooling pipelines. The steel ball valve can also be used in heating and cooling systems and applications where the water is oxygen free. Vexve's steel ball valve is also suitable for oil piping systems.

Vexve's steel ball valve can be used within the following temperature-pressure range. Please note that the maximum allowable working pressure depends on the operating temperature.

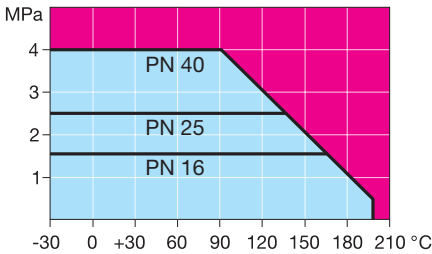

Chart 1.

Pressure-temperature chart
DN 10-DN 600 reduced bore.

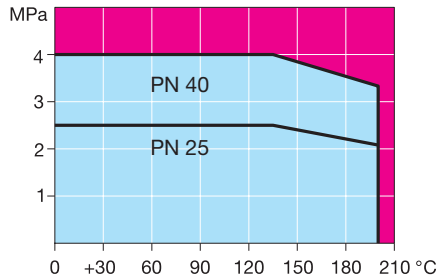

Chart 2.

Pressure-temperature chart
DN 600 full bore-DN 800 full bore.



NOTE:

When intending to use the valve for other media or applications please contact Vexve to ensure its suitability.

Parts lists for Vexve's steel ball valves are presented in Appendices 7.1 and 7.2

For detailed technical information including dimensions and weights, torques, Kv-values etc please refer to Vexve's Product catalogue or data sheets (www.vexve.com).

2. Valve identification

The identification plate locates at the valve body. It has the following information:

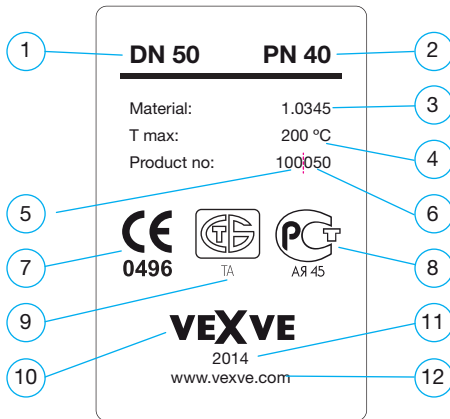

Figure 1. Identification plate.

1. Valve DN size
2. Pressure class
3. Valve Body Material
4. Maximum Allowable Temperature
5. Valve type
6. Valve DN size
7. CE-Mark and the number of the notified body
8. Russian Valve Certification
9. Belarus Valve Certification
10. Manufacturer
11. Manufacturing Year
12. Manufacturer's Internet Site

The type code for Vexve's ball valves is presented in Appendix 7.3.

3. Unloading and storage

Check that the contents of the delivery is as ordered. Check that the valve and related equipment have not been damaged during transportation.

Store the valve carefully before installation, preferably in a well-ventilated, dry place, on a shelf or a wooden grid to protect it from rising damp.

Protect bare metal surfaces, shaft parts, and flange surfaces with anti-corrosive agent before storage.

The valve must be transported to the installation site in a sturdy package. Do not remove the flow port protectors before installation. Protect the valve from sand, dust, and other impurities.

Use lifting ropes when lifting the large size valves. It is forbidden to lift the valve by its actuator or stem (see Figures 2 and 3).



NOTE:

Take the weight of the valve into account when handling it.

When delivered, the valve is in the open position. During storage, the valve must also be in the open position.

The maximum storage time is two years.

Packaging:

Vexve's products are protected during transportation with special packaging. The packaging consists of environmentally friendly materials that are easy to sort and recycle.

Recycling the packaging materials at designated waste collection points is recommended.

The following packaging materials are used: wood, cardboard, paper, and polyethylene sheets.

Recycling and disposal

Nearly all parts of the valve are made of recyclable materials. The material type is marked on most parts. Separate recycling and disposal instructions are available from the manufacturer. The valve can also be returned to the manufacturer for recycling and disposal against a fee.

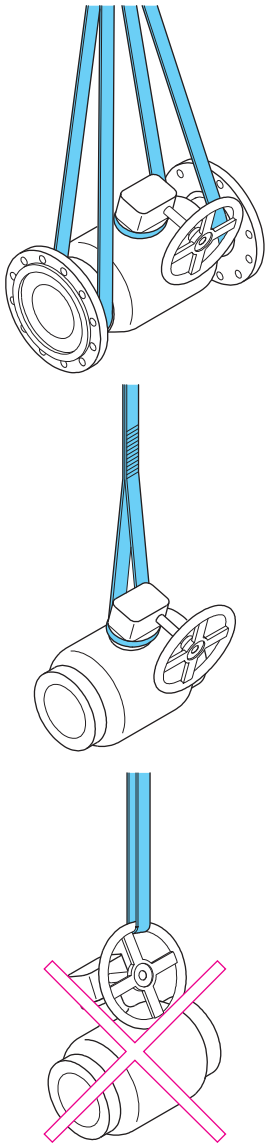

Figure 2. Lifting the valve \leq DN600 reduced bore.

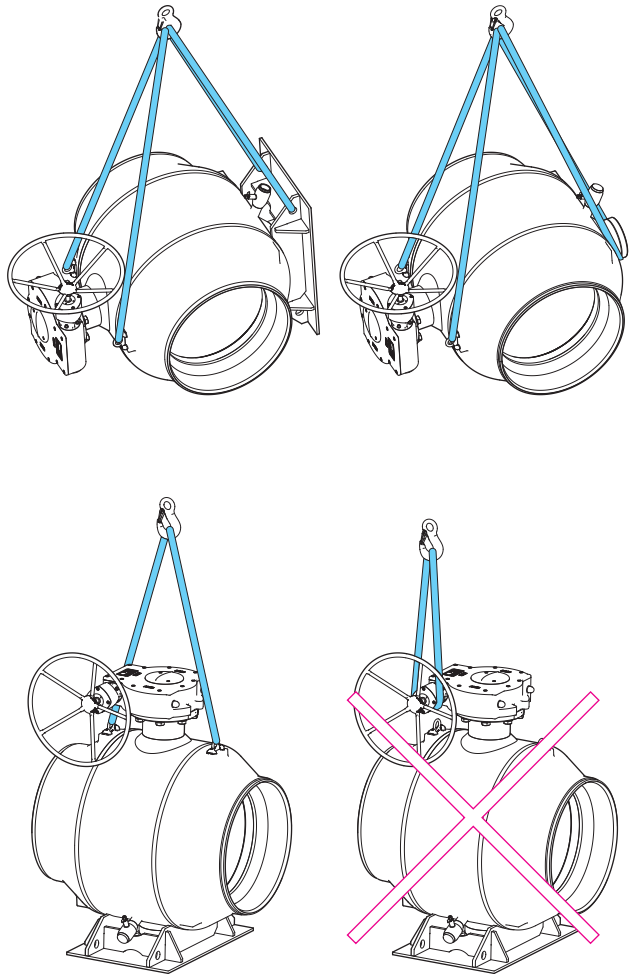

Figure 3. Lifting the valve \geq DN600 full bore.

4. Valve installation



WARNING:

Incorrect installation may result in serious personal injury and it may damage or cause malfunction of the equipment. These instructions must therefore be followed carefully when installing the valve.

These general instructions do not cover all possible operating scenarios. For more specific guidance on the use of the valve or its suitability for an intended use, please contact the manufacturer.

- Do not remove the flow port protectors before installation. Keep the valve protected from sand, dust, and other impurities.
- If the valve was delivered with the actuator installed, avoid removing the actuator during installation.
- Incorrect re-installation or adjustment of the actuator will result in a high risk of damage and leakage.
- Exercise extreme caution when testing the valve before installation in the pipeline.
- The valve or valve assembly must not be lifted from the actuator. If the valve is equipped with lifting lugs, use them (see Figure 3). Dropping or incorrect lifting of the valve can result in personal injury or equipment damage.
- Use one of the allowed lifting methods shown in Figures 2. and 3.



NOTE:

The valve must be used only in applications for which it is intended.

Prior to installation:

- Remove the flow port protectors and check that the inside of the valve is clean.



WARNING:

The pipeline and valve shall be carefully cleaned prior to installation as any welding debris or other impurities can damage the valve.

4.1 Installation of valve with weld connections

4.1.1 Steel ball valves < DN300 reduced bore

It is recommended to use the electric welding (TIG, MIG).

Valve size DN 125 and bigger must be welded to the pipeline by using electric welding.

Welding

Do not overheat the valve. Use cooling during the welding. Use wet fabric to protect the valve seat from excess heat during the welding. The welder should have the proper qualification to do this kind of welding procedures.

The valve must first be bridged to the pipeline using spot welding, with 4–8 seams alternately on opposite sides of the valve.

When valve is installed in a horizontal position:

When welding the valve, it must be in the open position in order to protect the surface of the ball from welding contamination (See Figure 4.3).

When valve is installed in a vertical position:

When making the upper seam welding, the valve must be open in order to protect the surface of the ball from welding contamination (See Figure 4.1).

When making the lower welding seam the valve must be closed to avoid the overheating of the valve (See Figure 4.2).

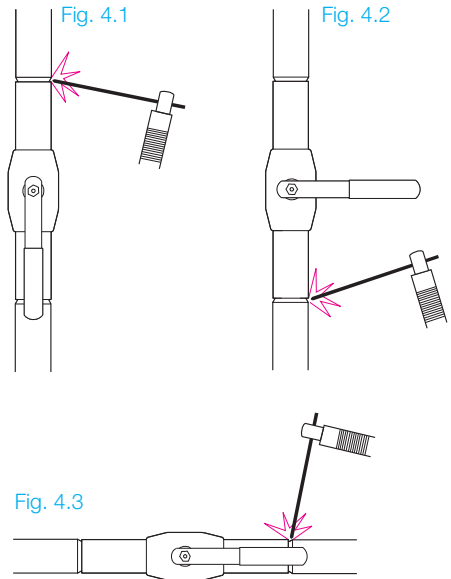

Figure 4.1. Vertical position.

When welding the upper seam the valve must be in open position.

Figure 4.2. Vertical position.

When welding the lower seam the valve must be in closed position.

Figure 4.3. Horizontal position.

The valve must be in open position.

Cool down the valve (after welding) before normal operation. The valve may not be opened or/and closed after the welding before it has cooled down.

4.1.2 Steel ball valves \geq DN300 reduced bore



NOTE:

Electric welding must be used to weld the valve in place.

- A valve may be welded only by an authorized mechanic, following valid norms and standards.
- The valve must remain open during installation and welding to ensure that welding residue does not damage the seal surfaces.
- The ends of the pipes must be parallel to the valve and correctly aligned.
- The length of the valve must be the same as the distance between the pipe ends, taking into consideration the welding gaps.
- The inner diameter of the pipes must be the same as the inner diameter of the ends of the valve.
- Recommended installation position for the valve is with the shaft in the vertical or horizontal position.

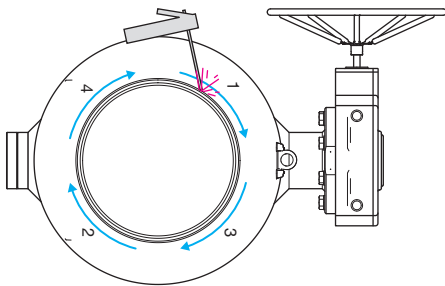

Figure 5. Welding the seams.



NOTE:

The recommended installation position for the valve is with the shaft in the vertical or horizontal position.

- The valve must first be bridged to the pipeline using spot welding, with 4–8 seams alternately on opposite sides of the valve.
- Then the seams between the bridges are welded as shown in Figures 5. and 6. Welding order: 1-2-3-4.
- Any lid welding must be carried minimum at 200 mm from the valve seam.
- During welding the ground must be connected to the pipe of the valve body or the pipeline. Never connect the ground to the valve neck, actuator flange or actuator.

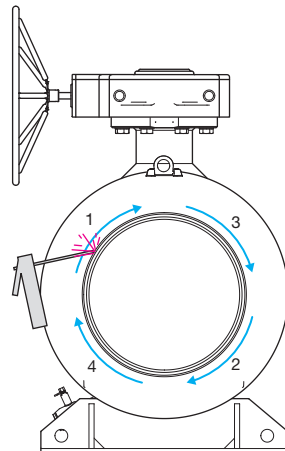

Figure 6. Welding the seams.

4.2 Installation of valve with flanges

- Valve may be installed only by an authorized mechanic, following valid norms and standards.
 - The valve must remain open during installation to ensure that any residue or dirt does not damage the sealing faces
 - The sealing faces of the pipe flanges must be parallel to the valve sealing faces and correctly aligned.
 - The length of the valve must be the same as the distance between the flanges in the pipe line, taking into consideration the gasket.
 - The flanges in the pipeline must be compatible with valve flanges. For detailed information please refer to the standard EN1092-1.
- The bolts and nuts used on installation must be selected to match operating conditions at installation location. Bolts and nuts must also fulfill requirements of the pressure, temperature, flange material and gasket. For detailed information please refer to the standards EN 1515-1, EN1515-2 and 1515-4.
 - The gasket used on installation must be selected to match operating conditions, temperature, pressure and medium. Gasket dimensions must be compatible with sealing faces of the flanges. For detailed information please refer to the standard EN1514.
 - Recommended installation position for the valve is with the shaft in the vertical or horizontal position.

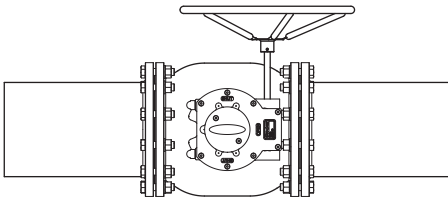

Figure 7. Horizontal installation.

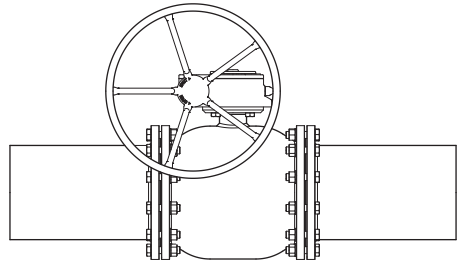

Figure 8. Vertical installation.

4.3 Installation at the end of pipeline



NOTE:

Do not use the valve at the end of the pipeline – a blank flange must always be installed after the valve (see Figure 9. and 10.).

When the valve is installed at the end of the pipeline, there is a risk of corrosion-causing oxygen-rich water or air collecting on the empty rear side of the valve. To prevent corrosion, the space after the valve must be filled with oxygen-free water.

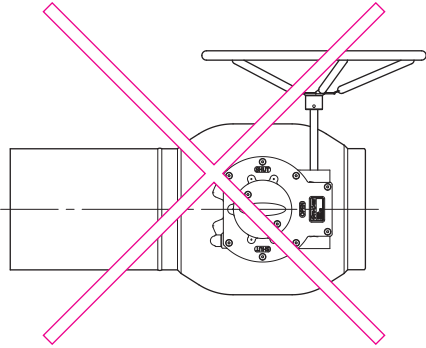

Figure 9. Do not use the valve at the end of the pipeline.

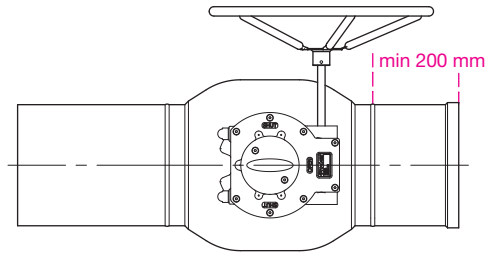

Figure 10. Blank flange.

Min. 200 mm pipe must be installed between the valve and the blank flange.



NOTE:

If the valve is located near to the blind flange at the end of the pipeline, valve must be in the fully open position to prevent a closed space from forming between the valve and blind flange. If water in the closed space expands (for example due to temperature), it may damage the valve.

4.4 Before commissioning

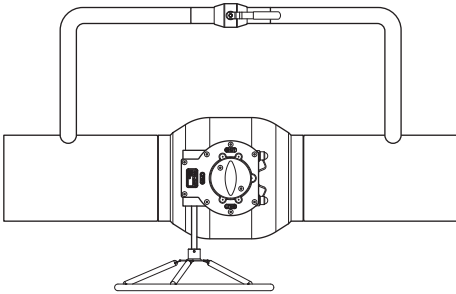

To avoid pressure shocks and to reduce the forces caused by opening the valve under pressure, it is recommended to use a by-pass valve in connection with ball valves of size DN150 and larger (see Figure 11).

Figure 11. By-pass valve.

4.5 Commissioning and Pressure testing

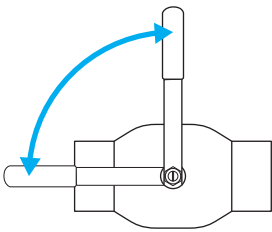

Figure 12. Check that the valve is either in an open or close position.

Exceeding of permitted values marked on the valve may damage the valve and, in the worst case, cause uncontrolled venting of the pressure. This leads to equipment damage and possibly also to personal injuries. The largest allowable testing pressure is $1,1 \times P_N$, when the valve is closed. During the pipeline pressure testing ($1,5 \times P_N$), the valve must be open.

The shut-off valves are designed to be fully open or close. Check that the valve is either in an open or close position against the stopper. Do this either by turning the handle 90 degrees or if the valve is equipped with a manual gear or an actuator, operate the valve with the help of it.

5. Gear and actuator disassembly and installation



NOTE:

Avoid removing the actuator/gear from the valve. The actuator/gear has been calibrated at the factory to ensure that the valve is tight. If the actuator/gear is removed, it may have to be re-calibrated.

Vexve Oy accepts responsibility only for actuators/gears installed by Vexve.

Refer to the separate adjustment instructions, available from the manufacturer.



WARNING:

The manual gear or actuator may not be removed or dismantled if the valve is pressurized! It is recommended to use the special actuator removal tools!

Incorrect disconnection may cause serious personal injuries as well as malfunction and damage to the equipment. Extreme caution must be exercised during the disconnection!

Do not use too high torques to operate the valve. Too high torques can damage the valve or the actuator/gear!

5.1 Disassembly and reinstallation of ProGear/Rotork manual gear

Part numbers mentioned in this chapter refer to the figure 13.

Disassembly:

1. Turn the valve to the open position before removing the gear. Valve opens when you turn the hand wheel of the gear counterclockwise
2. Turn the hand wheel slightly towards the close position (clockwise) to release forces between the valve and the gear in order to make it easier to remove the gear. To do this, turn the hand wheel only that much that it rotates easily
3. Remove the bolts (2) of the position indicator plate and remove the position indicator plate (3). Mark the position of the valve stem to the bush of the gear (1) in order to make it easier to reinstall the gear back into the right position
4. Remove the attachment bolts of the gear and then remove the gear

Reinstallation:

5. When reinstalling the manual gear back to valve, check that the gear is in the right position
 - If the gear is installed back to its original position there is no need to adjust the gear settings
 - If the gear is turned 180 degrees from its original position, you must carefully check that the valve closes and opens correctly. If the mechanical limits (parts 4-7) are not correct you must adjust the gear as described in the chapter "5.2 Adjustment of manual gear"
6. Install the gear back to the valve and tighten the attachment bolts
7. Check that the valve opens and closes correctly. If the mechanical limits (parts 4-7) are not correct you must adjust the gear as described in the chapter "5.2 Adjustment of manual gear"

5.2 Adjustment of ProGear/Rotork manual gear

Part numbers mentioned in this chapter refer to the figure 13.

1. Remove the plastic dust caps (4) from the top of the mechanical limits. Open the locking nuts (5) and loosen the adjusting screws (6 & 7)
2. Turn the valve to the open position. Valve opens when you turn the hand wheel of the gear counterclockwise. Valve is in the open position when the flow port of the valve ball is concentric with the seat of the ball
3. Tighten the OPEN position adjusting screw (7) until it stops turning. Fix it with the locking nut (5) and put the dust cup in its place (4)
4. Turn the valve 90 degrees to the closed position. Valve closes when you turn the hand wheel of the gear clockwise
5. Tighten the CLOSE position adjusting screw (6) until it stops turning. Fix it with the locking nut (5) and put the dust cup in its place (4)
6. Check that the valve opens and closes correctly

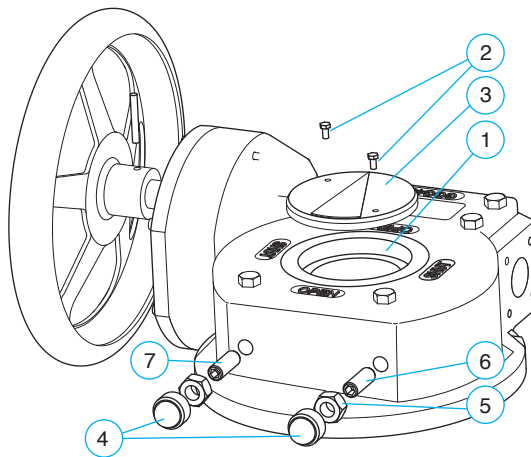

Figure 13. Manual gear.

5.3 Disassembly and reinstallation of AUMA electric actuator

Part numbers mentioned in this chapter refer to the figure 14.

Disassembly:

1. Before removing the actuator, turn the valve to the open position either electrically or manually by rotating the hand wheel (3) of the motor unit (2) counterclockwise
2. Turn off the power supply of the actuator
3. Turn the hand wheel (3) of the motor unit (2) slightly towards the close position (clockwise) to release forces between the valve and the actuator in order to make it easier to remove the actuator. To do this, turn the hand wheel (3) only that much that it rotates easily
4. Remove the bolts (4) of the position indicator plate. Remove the position indicator plate (5), the retaining ring (6) and the cover plate (7)
5. Before removing the actuator, mark the position and the place of the bushing (8) in relation to the actuator and the valve
6. Remove the attachment bolts of the actuator and remove the actuator. The bushing (8) will stay at the valve stem

Reinstallation:

7. When reinstalling the actuator back to the valve, check that the actuator is in the right position
 - If the actuator is installed back to its original position there is no need to adjust the actuator settings
 - If the actuator is turned 180 degrees from its original position, you must carefully check that the valve closes and opens correctly. If the actuator limits are not correct you must adjust the actuator as described in the chapter 5.4 "Adjustment of the mechanical limits of AUMA electric actuator"
8. Install the actuator back to the valve and tighten the attachment bolts of the actuator
9. Check that the valve opens and closes correctly. If the actuator limits are not correct you must adjust the actuator as described in the chapter 5.4 "Adjustment of the mechanical limits of AUMA electric actuator"

5.4 Adjustment of the mechanical limits of AUMA electric actuator

Part numbers mentioned in this chapter refer to the figure 14.

If the actuator is already installed to the valve, you can skip the points 1-8

1. Vexve ball valves are delivered from the factory in the open position. If the valve has been operated so that it is in some other position, turn the valve to the open position. Remove the device (handle/ actuator) that you used to operate the valve
2. Check that the valve stem is intact and clean. Check also that the key of the valve stem is properly in its groove
3. Put the bushing (8) on the valve stem and set it to the right depth. Check that the overlap between the valve stem and the bushing is long enough. Usually a proper gap between the bushing and the actuator flange of the valve is about 10 mm
4. Tighten the locking screw (9) with an Allen key
5. Turn the actuator to the open position
6. Install the actuator on the valve in the preferred position. The gear unit (1) must fit the bushing (8) easily and you must not force it in its place
7. Grease the attachment screws of the actuator. Put all the washers and the attachment screws first loosely in their places and finally tighten them up
8. (If the motor unit (2) is not installed to the gear unit (1), install it now. Put all the washers and the attachment screws first loosely in their places and finally tighten them up)
9. Turn the hand wheel (3) a couple of revolutions clockwise. Remove the attachment screws (10) of the limiting bush (11)
10. (Set the position and torque limit of the motor unit (or control unit if included) according to separate AUMA's instructions)
11. Turn the valve to the open position
12. Turn the limiting bush counterclockwise until it stops turning. Then turn it backwards (clockwise) app. 1/8 turn
13. Pull the limiting bush out and put it back in its place so that the holes of it will match the holes of the gear unit. Fasten the limiting bush (11) tightly with the attachment screws (10).
14. Check that the actuator works properly

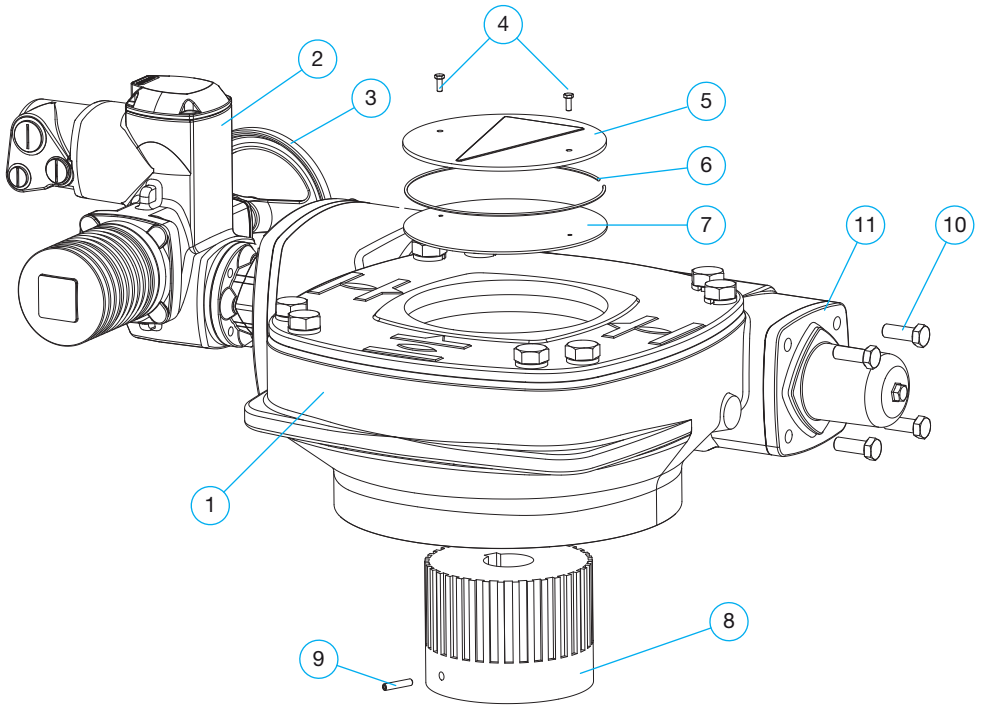

Figure 14. Electric actuator.

5.3 Assembly/disassembly of pneumatic actuator

Please refer to the separate installation/adjustment instructions, available from the manufacturer.

5.4 Assembly/disassembly of hydraulic actuator

Please refer to the separate installation/adjustment instructions, available from the manufacturer.

6. Maintenance

Vexve ball valves are virtually maintenance-free.

Correct choice of valve as well as careful installation, commissioning, and use significantly reduce any need for maintenance.



WARNING:

When the valve is installed in the line, its surface temperature may be dangerously high.
Protect yourself against burns.

We recommend checking the following periodically:

Check that the valve is free from surface damage and shaft leaks, and carefully repair any damage.

To ensure long-term operational reliability, even when seldom used (around ten times a year or less), we recommend the following:

Approximately six months after commissioning and then once a year, inspect the valve for shaft leaks, check the manual gear / actuator, and ensure the tightness of the screws between valves.

6.1 Replacing the O-ring seal of stem in valves DN10–DN50

manufactured 2006 or later

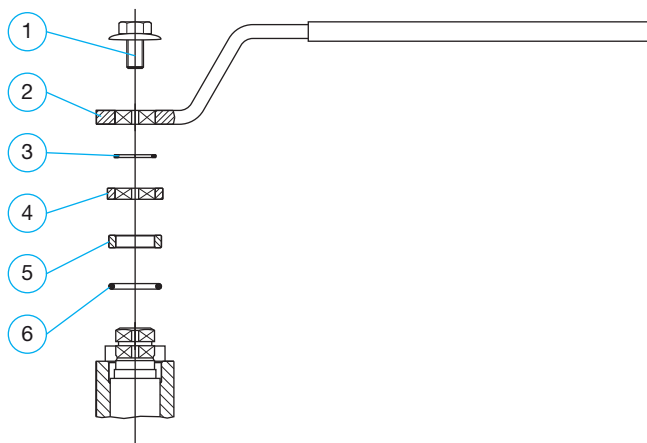

- remove the hex screw (1) and the handle (2)
- remove the retaining ring (3)
- remove the block stop (4) and the bush (5)
- remove the damaged o-ring (6)
- put the new o-ring (6) in its place by pressing it evenly downwards from its upper edge
- assemble removed parts in reverse order

	Part	DN10/15	DN20	DN25	DN32	DN40	DN50
1	Hex screw	001100	001100	001100	001100	001101	001101
2	Handle	930001	930001	930003	930003	930005	930005
3	Retaining ring	008003	008003	008002	008002	008001	008001
4	Block stop	940011	940011	940013	940013	940015	940015
5	Bush	940071	940071	940073	940073	940075	940075
6	O-ring	010011	010011	010012	010012	010013	010013

6.2 Replacing the O-ring seal of stem in valves DN65–DN150

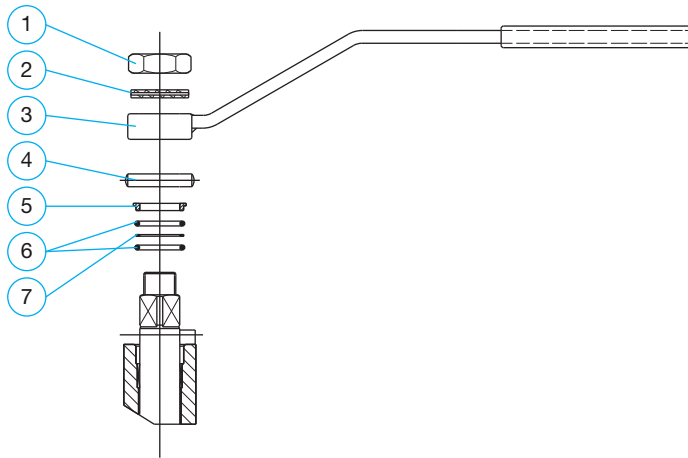

- remove the hex nut (1)
- remove the washer (2) and the handle (3)
- remove the slot pin (4)
- remove the bush (5)
- remove the upper o-ring (6), the distance plate (7) and the lower o-ring (6)
- put the new lower o-ring (6), the distance plate (7) and the new upper o-ring (6) in their places. Install the o-rings by pressing them evenly downwards from the upper edge
- assemble the rest of the removed parts in reverse order

	Part	DN65	DN80	DN100	DN125	DN150
1	Hex nut	006004	006004	006004	006003	006003
2	Washer	007005	007005	007005	007004	007004
3	Handle	930031	930031	930030	930178	930177
4	Slot pin	004005	004005	004004	004003	004003
5	Bush	940003	940003	940004	940002	940002
6	O-ring	010014	010014	010015	010016	010016
7	Distance plate	940009	940009	940012	940010	940010

6.3 Replacing the O-ring seal of stem in valves with actuators DN65–DN150

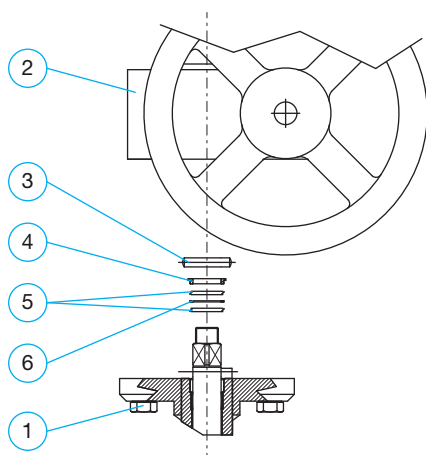

NOTE!

Clean the stem hole of the actuator before reinstalling the actuator. Actuator must fit the stem easily so that it won't press the stem downwards.

- remove the hex screws (1), the actuator (2), the slot pin (3) and the bush (4)
- remove the upper o-ring (5), the distance plate (6) and the lower o-ring (5)
- put the new lower o-ring (5), the distance plate (6) and the new upper o-ring (5) in their places. Install the o-rings by pressing them evenly downwards from the upper edge
- assemble the rest of the removed parts in reverse order

	Part	DN65	DN80	DN100	DN125	DN150
1	Hex screw	002005	002005	002005	001034	001034
2	Actuator	x	x	x	x	x
3	Slot pin	004005	004005	004004	004003	004003
4	Bush	940003	940003	940004	940002	940002
5	O-ring	010014	010014	010015	010016	010016
6	Distance plate	940009	940009	940012	940010	940010

6.4 Replacing the O-ring seal of stem in valves DN200–DN300

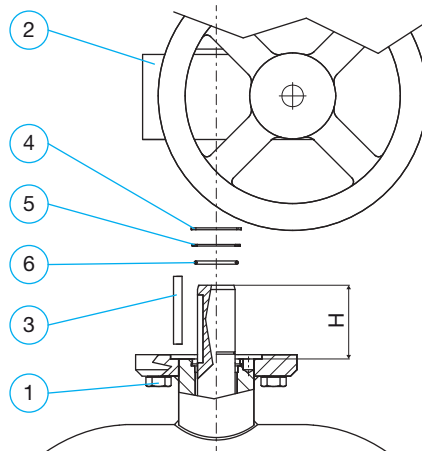

NOTE!

When reassembling, be sure to put the retaining ring (4) properly into its groove in the stem and make sure that the stem is in the right position >> Check the height H from the table below.

Make sure that the gap in the retaining ring (4) is not located in the same place with the key (3). Clean the stem hole of the actuator before reinstalling the actuator (2). Actuator must fit the stem easily so that it won't press the stem downwards.

- remove the hex screws (1) and the actuator (2)
- remove the key (3), the retaining ring (4) and the top distance plate (5)
- remove the damaged o-ring (6)
- put the new o-ring (6) in its place by pressing it evenly downwards from its upper edge
- assemble the rest of the removed parts in reverse order

	Part	DN200	DN250	DN300
1	Hex screw	001031	001032	981166
2	Actuator	x	x	x
3	Key	040002	040001	040005
4	Retaining ring	008010	009006	009008
5	Top distance plate	940068	940037	940164
6	O-ring	010017	010018	010024
H	Height [mm]	68	84	94

6.5 Replacing the O-ring seal of stem in valves DN350–DN800



NOTE!

When reassembling, be sure to put the retaining ring (4) properly into its groove in the stem and make sure that the stem is in the right position >> Check the height H from the table below.

Make sure that the gap in the retaining ring (4) is not located in the same place with the key (3).

Clean the stem hole of the actuator before installing the actuator (2). Actuator must fit the stem easily so that it won't press the stem downwards.

- remove the hex screws (1) and the actuator (2)
- remove the key (3) and the retaining ring (4)
- remove the bush (5). See the following instructions for different valve sizes:
 - DN350-600: Simply remove the top distance plate/sealing bush (5)
 - DN700-FB 800: First, remove the hex socket screws (5.1) (4 pcs). Then, remove the bush (5)
TIP: You can remove the bush with the help of M12 screws (A): drive the screws into the bush (5) and pull it away. (Screw holes of the bush are equipped with M12 thread. Screws (5.1) that you removed earlier are M10 screws)
- remove the upper o-ring, the distance plate (7) and the lower o-ring
- put the new lower o-ring (6), distance plate (7) and the new upper o-ring (6) in their places. Install the o-rings by pressing them evenly downwards from the upper edge
- assemble the rest of the removed parts in reverse order

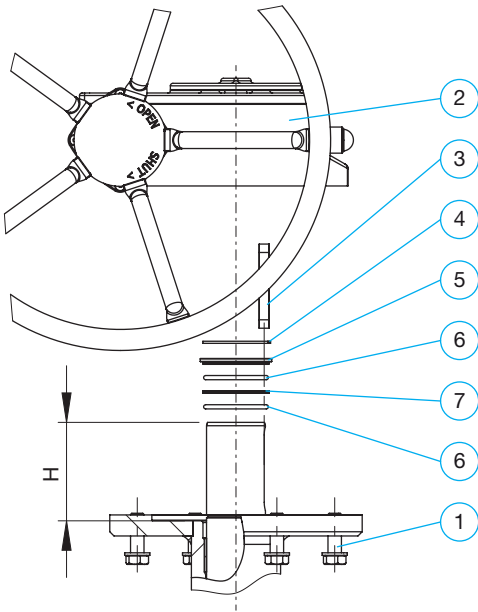

DN350-DN600

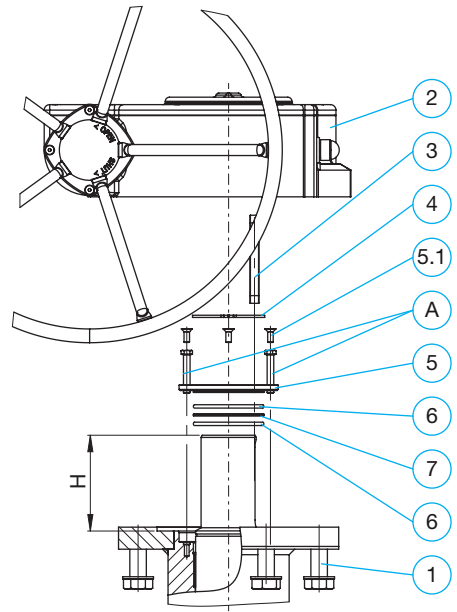

DN700-DN800

Part	DN350	DN400	DN500	DN600	DN700	DN800	DN800 full bore
1 Hex screw	981166	981167	981171	981171	981117	981117	982170
2 Actuator	x	x	x	x	x	x	x
3 Key	070005	070006	070007	070007	981008	981009	982415
4 Retaining ring	009008	070014	070015	070015	908165	908166	908167
5 Top distance plate/Sealing bush	940164	970038	970039	970039	908065	908066	908067
5.1 Hex socket screw	-	-	-	-	908126	908126	908126
6 O-ring	010024	070002	070003	070003	908109	908110	908111
7 Distance plate	940163	970058	970059	970059	908060	908061	908062
H Height [mm]	86	117	121	122	174	174	227
A Screw (M12) for removing the bush	-	-	-	-	x	x	x

7. Appendices

7.1 Parts list for steel ball valves < DN200

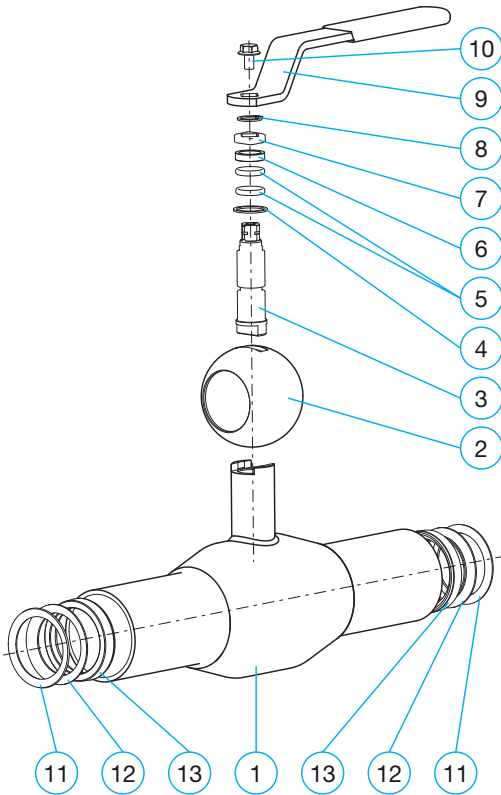

Part number		qty
1	Valve body	1
2	Ball	1
3	Stem	1
4	Sliding plate	1
5	O-ring	2
6	Bush	1
7	Block stop	1
8	Retaining ring	1
9	Handle	1
10	Hex flange bolt	1
11	Spring plate	2
12	Support plate	2
13	Ball seal	2

7.2 Parts list for steel ball valves \geq DN200

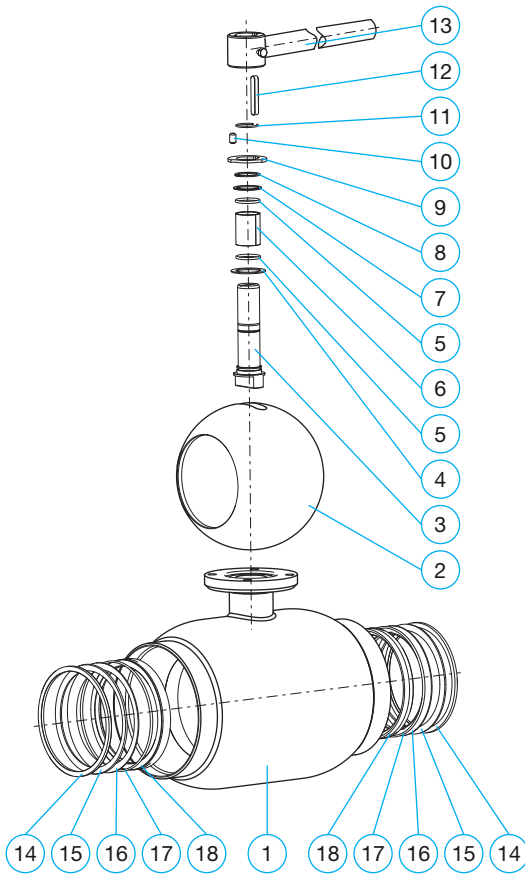

Part number		qty
1	Valve body	1
2	Shell ball	1
3	Stem	1
4	Sliding plate	1
5	O-ring	2
6	Sliding bearing	1
7	Top distance plate	1
8	Retaining ring	1
9	Block stop	1
10	Dowel pin	1
11	Retaining ring	1
12	Key	1
13	Handle	1
14	Retaining ring	2
15	Spring plate	2
16	Support plate	2
17	O-ring	2
18	Ball seal	2

7.3 Type code

Type codes of Vexve steel ball valves consist of six (6) digits as described in the table below:

	1.	2.	3.	4.	5.	6.
0		Water valve (reduced bore)	with weld connections	DN	DN	DN
1	Steel ball valve		with female threads / weld connection	DN	DN	(F-F) *
2			with female threads	DN	DN	DN
3			with flanges	DN	DN	DN
4			shut off valve with a manual gear	DN	DN	DN
5		Full bore valve	with flange / weld connection	DN	DN	DN

* The final digit in the type code of valves with both manual gear and flanged ends is 1.

In some cases there might be extra characters after the type code, most common of those are presented in the table below:

Extra characters	Meaning
/GS	Valve with GOST weld connections
/S	Valve for higher axial loads
/HG	Valve with a vertical gear
/F05 ... /F10	Valve with an actuator flange

Example

- 100100 Reduced bore steel ball valve with welded connections, valve size DN 100
- 153040 Full bore steel ball valve with flanged connections, valve size DN 40
- 104200/GS Reduced bore steel ball valve with a manual gear and GOST weld connections, valve size DN 200

Should you have any questions concerning the type codes of Vexve valves, please contact the manufacturer.

7.4 Coupling dimensions, reduced bore ball valves DN15–800 with actuators

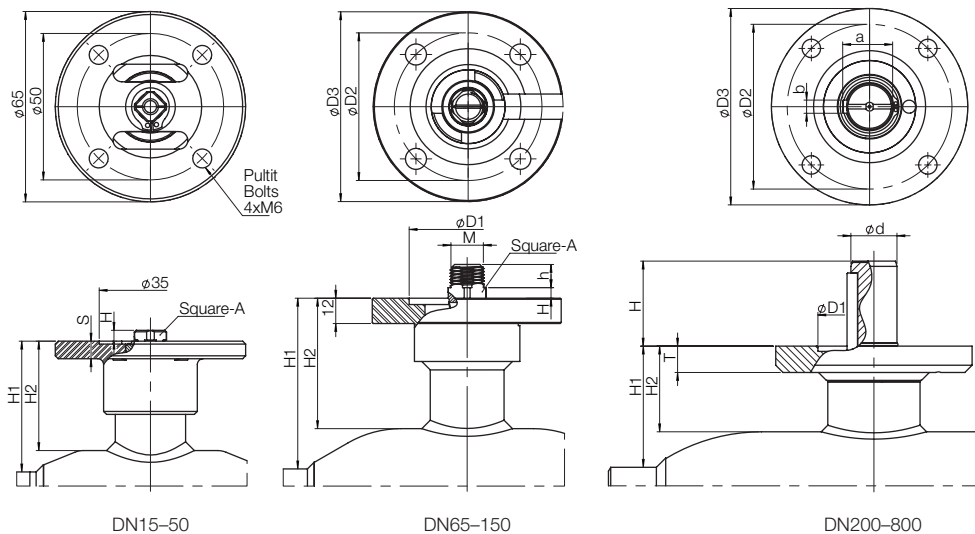

DN	H	h	S	A	M	Ød	T	H1	H2	a	b	D1	D2	D3	Bolts	Key	Flange ISO5211
15	4.3		5	7				26	20								F05
20	4.3		5	7				28	20								F05
25	3.7		6	9				45	37								F05
32	3.7		6	9				44	35								F05
40	5.2		8	11				64	50								F05
50	5.2		8	11				64	50								F05
Toler.				-0.1													

65	5	11		14	M16x1,5			81	62			55	70	90	4xM8		F07
80	5	11		14	M16x1,5			87	62			55	70	90	4xM8		F07
100	7	11		16	M16x1,5			108	81			55	70	90	4xM8		F07
125	15	14		20	M20x1,5			108	89			70	102	125	4xM10		F10
150	15	14		20	M20x1,5			114	89			70	102	125	4xM10		F10
Toler.				-0.1													

200	65					35	20	92	65	38	10	85	125	149	4xM12	A-10x8 - 63	F12
250	79					40	20	108	67	43	12	100	140	179	4xM16	A-12x8 - 80	F14
300	88					50	20	133	67	53.5	14	130	165	209	4xM20	A-14x9 - 90	F16
350	80					50	20	192	116	53.5	14	130	165	209	4xM20	A-14x9 - 80	F16
400	110					70	25	242	141	74.5	20	200	254	300	8xM16	A-20x12 - 100	F25
500	115					90	40	259	183	95	25	230	298	350	8xM20	A-25x14 - 100	F30
600	115					90	40	274	173	95	25	230	298	350	8xM20	A-25x14 - 100	F30
700	167					100	40	336	210	105	28	260	356	415	8 x M30	A-28x16 - 160	F35
800	167					120	40	365	210	127	32	260	356	415	8 x M30	A-32 x18 - 160	F35
Toler.						-0.1											

7.5 Coupling dimensions, full bore ball valves DN10–800 with actuators

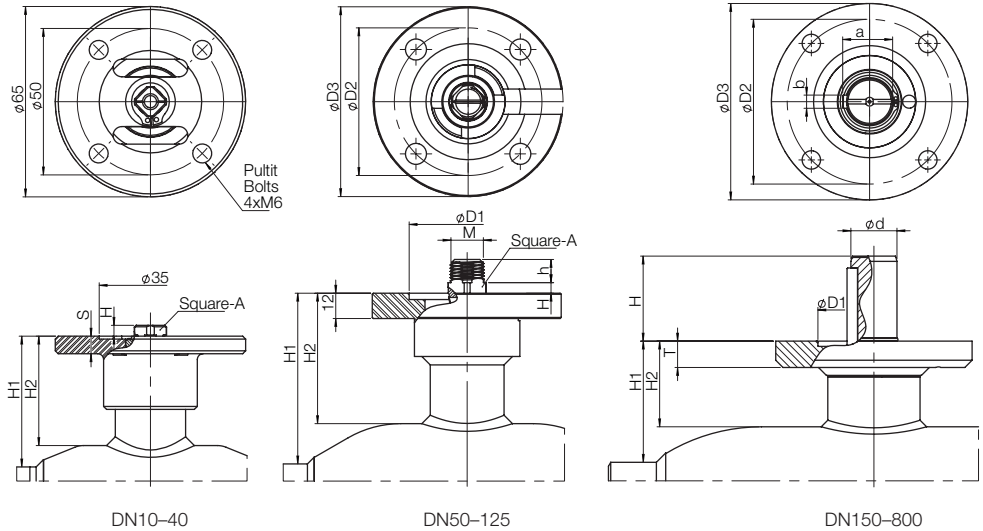

DN	H	h	S	A	M	Ød	T	H1	H2	a	b	D1	D2	D3	Bolts	Key	Flange ISO5211
10	4.3		5	7				26	20								F05
15	4.3		5	7				31	20								F05
20	3.7		6	9				48	37								F05
25	3.7		6	9				48	35								F05
32	5.2		8	11				67	50								F05
40	5.2		8	11				70	50								F05
Toler.				-0.1													

50	5	11		14	M16x1,5			89	62			55	70	90	4xM8		F07
65	5	11		14	M16x1,5			93	62			55	70	90	4xM8		F07
80	7	11		16	M16x1,5			121	81			55	70	90	4xM8		F07
100	15	14		20	M20x1,5			121	89			70	102	125	4xM10		F10
125	15	14		20	M20x1,5			128	89			70	102	125	4xM10		F10
Toler.				-0.1													

150	65					35	20	118	65	38	10	85	125	149	4xM12	A-10x8 - 63	F12
200	79					40	20	135	67	43	12	100	140	179	4xM16	A-12x8 - 80	F14
250	88					50	20	158	67	53.5	14	130	165	209	4xM20	A-14x9 - 90	F16
300	80					50	20	208	116	53.5	14	130	165	209	4xM20	A-14x9 - 80	F16
350	110					70	25	267	141	74.5	20	200	254	300	8xM16	A-20x12 - 100	F25
400	115					90	40	309	183	95	25	230	298	350	8xM20	A-25x14 - 100	F30
500	115					90	40	325	173	95	25	230	298	350	8xM20	A-25x14 - 100	F30
600	167					100	40	387	210	105	28	260	356	415	8 x M30	A-28 x 16 - 160	F35
700	167					120	40	417	210	127	32	260	356	415	8 x M30	A-32 x 18 - 160	F35
800	220					140	40	449	210	148	36	325	406	475	8 x M36	A-36 x 20 - 200	F40
Toler.						-0.1											



VEXVE OY

Vexve Oy

Pajakatu 11
FI-38200 Sastamala, Finland

Tel.: +358 10 734 0800

Fax: +358 10 734 0839

vexve.customer@vexve.com

Naval Oy

P.O.Box 32
FI-23801 Laitila, Finland

Tel.: +358 10 734 0500

Fax: +358 2 856 506

naval.customer@naval.fi

www.vexve.com

www.naval.fi



9/2014