

E	Gebrauchsanleitung / Montageanleitung	2
R	Mode d'emploi / Instructions de montage	3
N	Instructions for use / assembly instructions	4
I	Istruzioni per l'uso / Istruzioni per Installazione	5
S	Modo de empleo / Instrucciones de montaje	6
U	Gebruiksaanwijzing / Handleiding	7
X	Brugsanvisning / Monteringsvejledning	8
I	Instruções para uso / Manual de Instalação	9
L	Instrukcja obsługi / Instrukcja montażu	10
S	Návod k použití / Montážní návod	11
K	Návod na použití / Montážny návod	12
H	用户手册 / 组装说明	13
U	Руководство пользователя / Инструкция по монтажу	14
I	Käyttöohje / Asennusohje	15
V	Bruksanvisning / Monteringsanvisning	16
I	Vartotojo instrukcija / Montavimo instrukcijos	17
R	Upute za uporabu / Uputstva za instalaciju	18
R	Kullanım kılavuzu / Montaj kılavuzu	19
O	Manual de utilizare / Instrucțiuni de montare	20
L	Οδηγίες χρήσης / Οδηγία συναρμολόγησης	21
L	Navodilo za uporabo / Navodila za montažo	22
T	Kasutusjuhend / Paigaldusjuhend	23
V	Lietošanas pamācība / Montāžas instrukcija	24
R	Uputstvo za upotrebu / Uputstvo za montažu	25
O	Bruksanvisning / Montasjeveiledning	26
G	Инструкция за употреба / Ръководство за монтаж	27
Q	Udhëzuesi i përdorimit / Udhëzime rreth montimit	28
R	دليل الاستخدام / تعليمات التجميع	29
U	Használati útmutató / Szerelési útmutató	30
P	取扱説明書 / 施工説明書	32

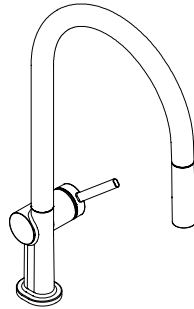

Talis M54 210 2jet
72800XXX

Talis M54 210 Eco 2jet
72842XXX

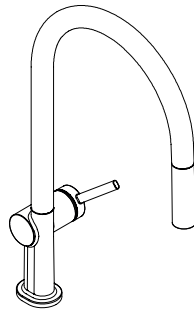

Talis M54 210 1jet
72802XXX

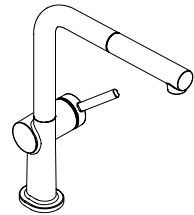

Talis M54 270 1jet
72808XXX

Talis M54 270 Eco 1jet
72845XXX

 **Sikkerhetshenvisninger**

- △ Bruk hansker under montasjen for å unngå klem- og kuttskader.
- △ Store trykkdifferanser mellom kaldt- og varmtvannstilkoblinger skal utlignes.

Montagehenvisninger

- Før montasjen skal produktet sjekkes for transportskader. Etter monteringen aksepteres ikke noen transport- eller overflateskader.
- Ledningene og armaturen skal monteres, spyles og sjekkes iht. de gyldige normer.
- Gjeldende retningslinjer for rørleggerarbeid i de enkelte land skal følges.
- 72842XXX, 72845XXX: Armaturen kan ikke brukes i forbindelse med en gjennomstrømningsvarmer.

Tekniske data

Driftstrykk maks. 1 MPa
 Anbefalt driftstrykk: 0,1 - 0,5 MPa
 Prøvetrykk 1,6 MPa
 (1 MPa = 10 bar = 147 PSI)
 Varmtvannstemperatur maks. 70 °C
 Anbefalt temperatur for varmt vann 65 °C
 Termisk desinfisering: maks. 70 °C / 4 min
 Produktet er utelukkende designet for drikkevann!

Symbolbeskrivelse

 Ikke bruk silikon som inneholder eddiksyre!

 **Justering** (se side 39)

Innstilling av varmtvannsbegrensning. I forbindelse med gjennomstrømningsvarmere er det ikke anbefalt å bruke en varmtvannsperre.

 **Vedlikehold** (se side 48)

Funksjonen til returløpssperren skal iht. DIN EN 1717 og i samsvar med de nasjonale og lokale forskrifter sjekkes regelmessig (minst en gang i året).

 **Mål** (se side 40)

 **Gjennomstrømningsdiagram** (se side 40)

 **Servicedeler** (se side 45)

XXX = Fargekode
 000 = Krom
 670 = Matt Black
 800 = Rustfritt Stål Optikk

Ekstratilbehør (ikke med i leveransen)

 Adapter (G^{3/8} / G^{1/2})
 #93395000 (se side 45 / 47)

 **Rengjøring** (se side 43)

 **Betjening** (se side 44)

Om morgen og etter lengre stagnasjonstider anbefaler Hansgrohe å ikke bruke den første halvliteren som drikkevann.

Feil	Årsak	Feilrettelse
Armatyr ikke lett bevegelig	- Kartusj defekt, forkalkning	- Kartusj byttes
Armatyr drypper	- Kartusj defekt	- Kartusj byttes
Vannlekkasje på festeskift	- Tilkoblingslanger ikke skrudd helt inn i basiselement	- Tilkoblingslanger trekkes fast fra hånd
	- O-ring på tilkoblingslangen defekt	- O-ring byttes
For lav varmtvannstemperatur	- Varmtvannsbegrensning er feil innstilt	- Varmtvannsbegrensning innstilles

Montasje (se side 33) 

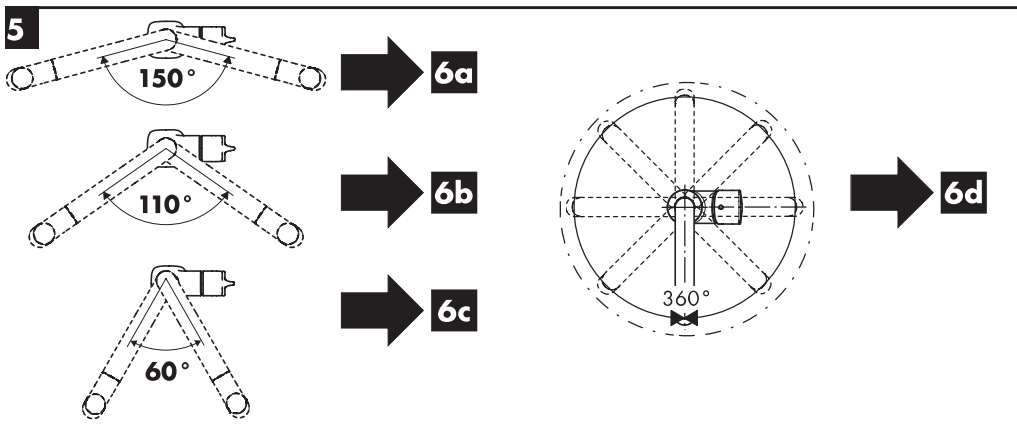
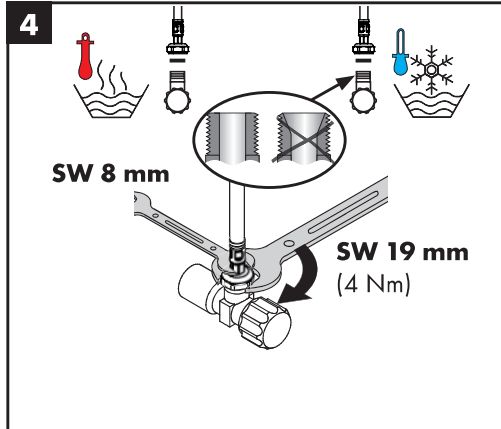
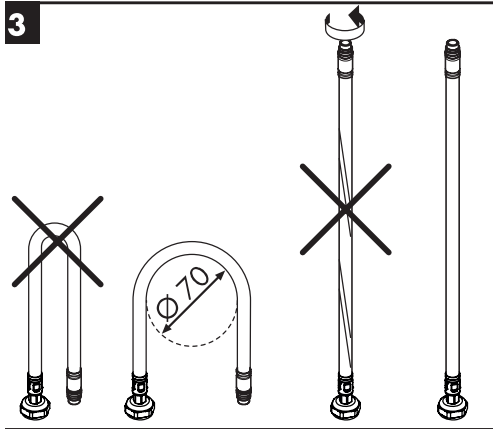
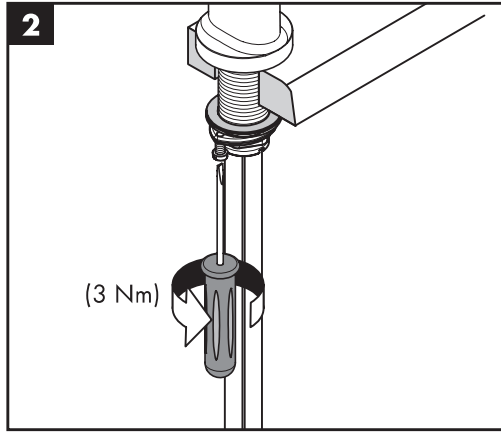
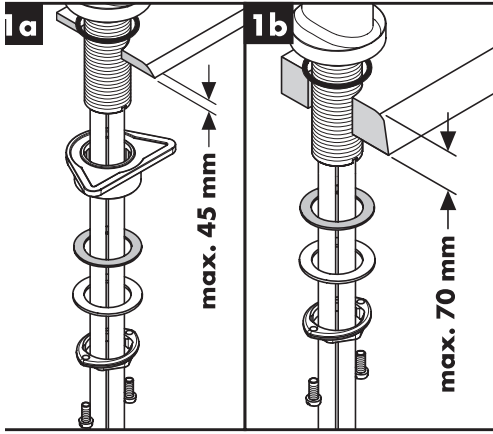



6a

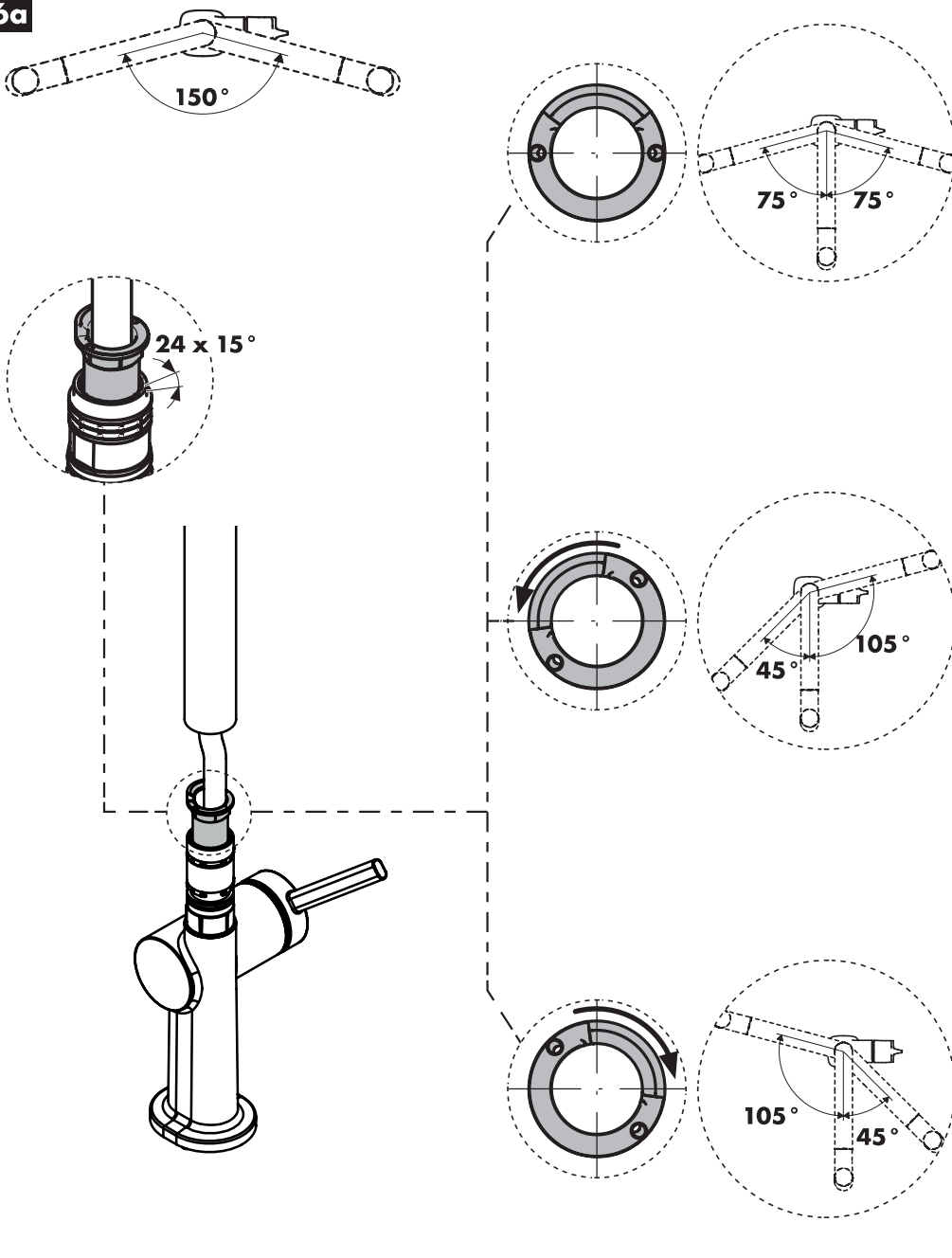



6b

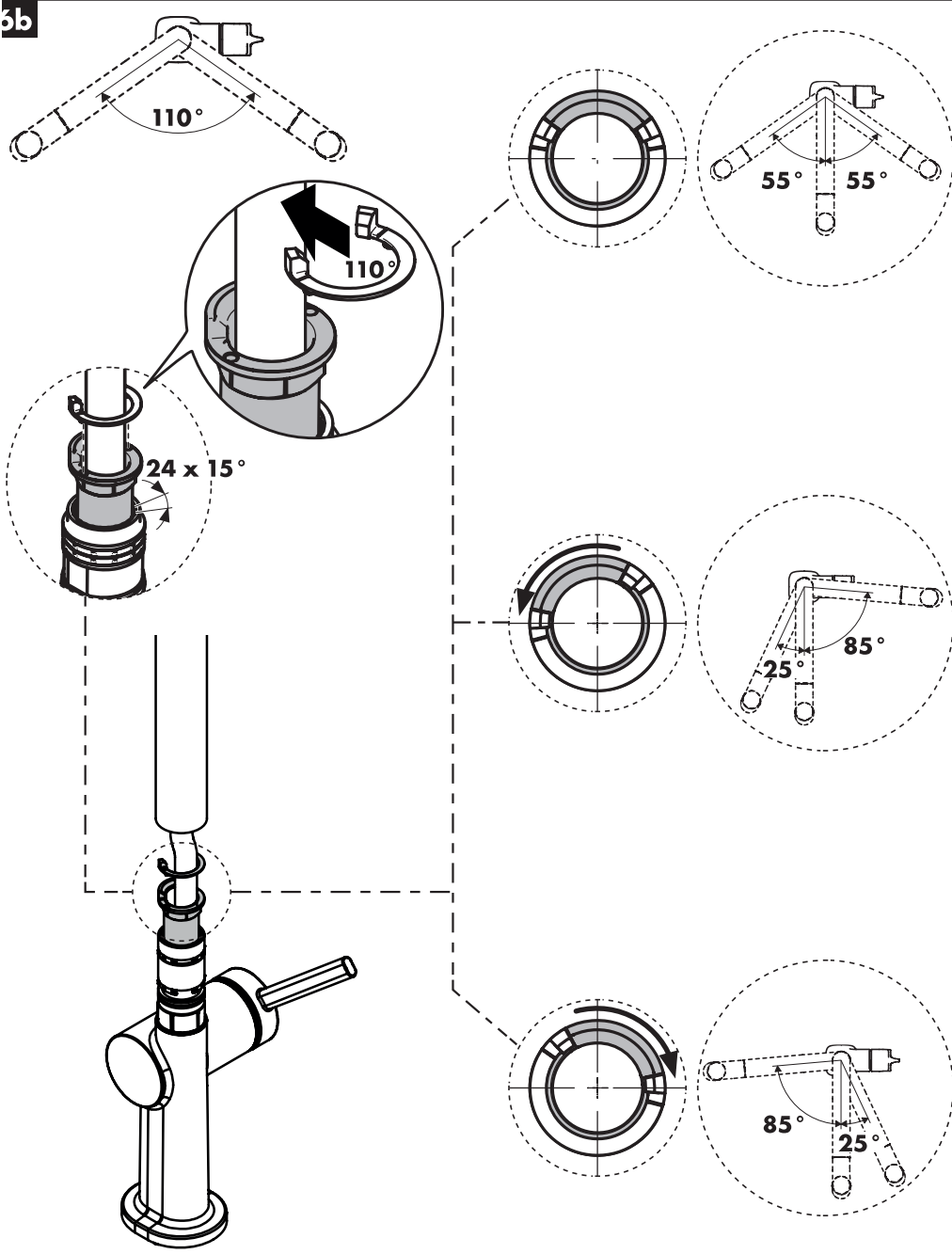



6c

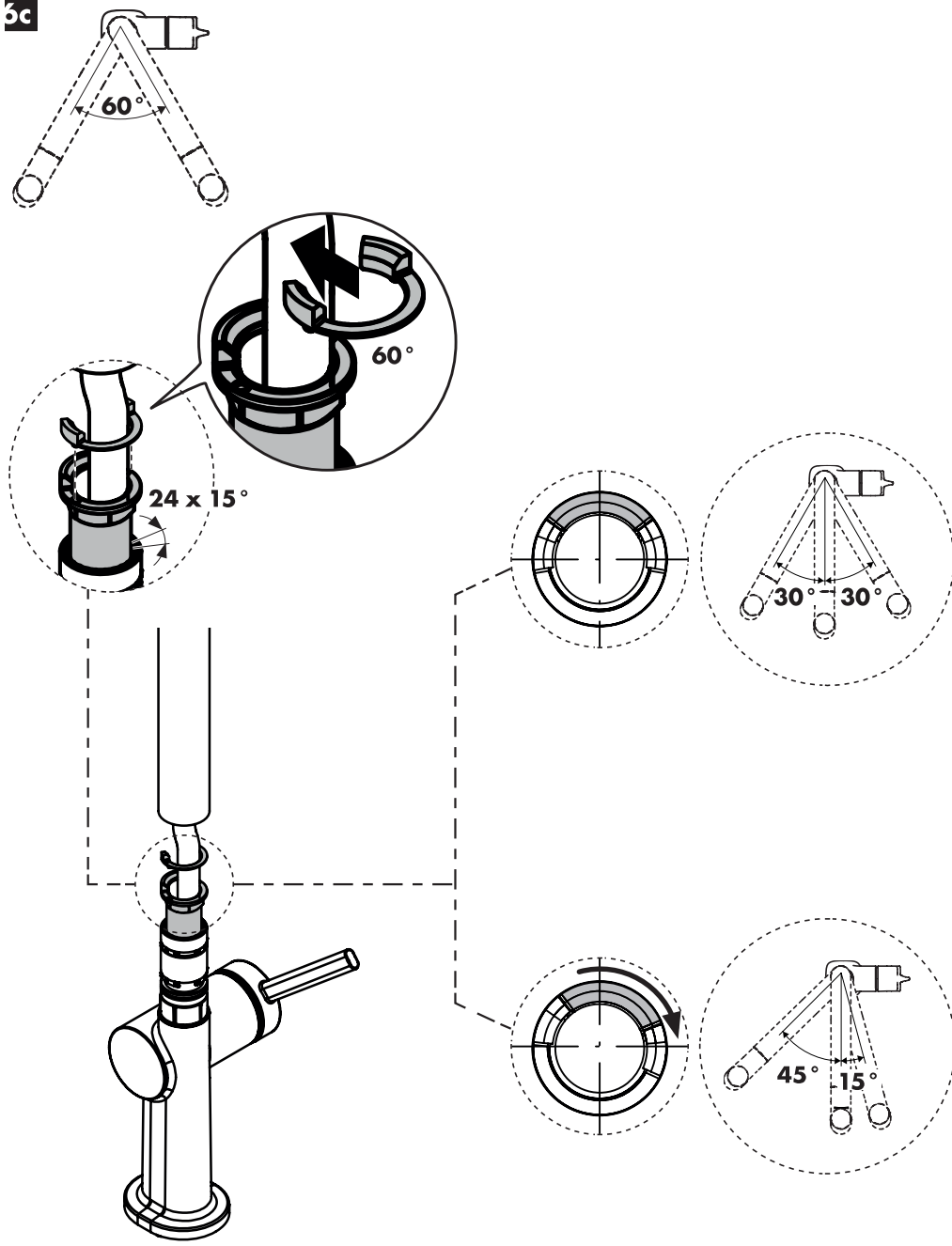

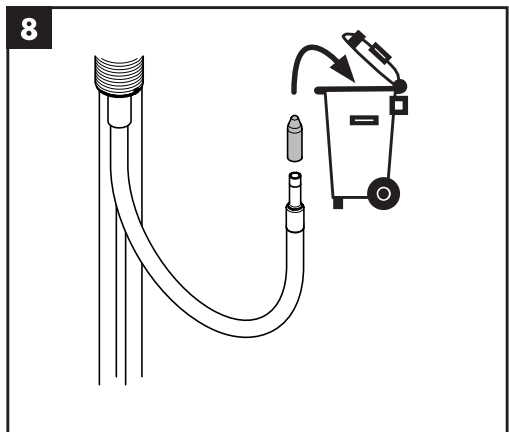
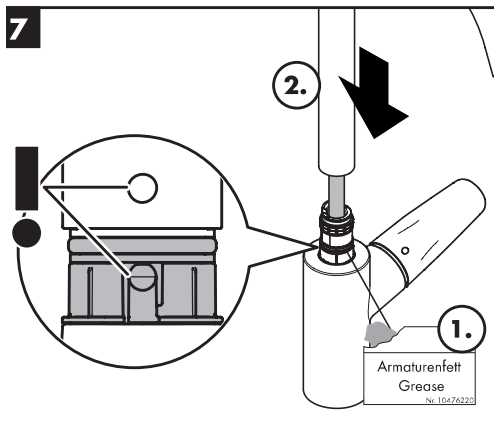
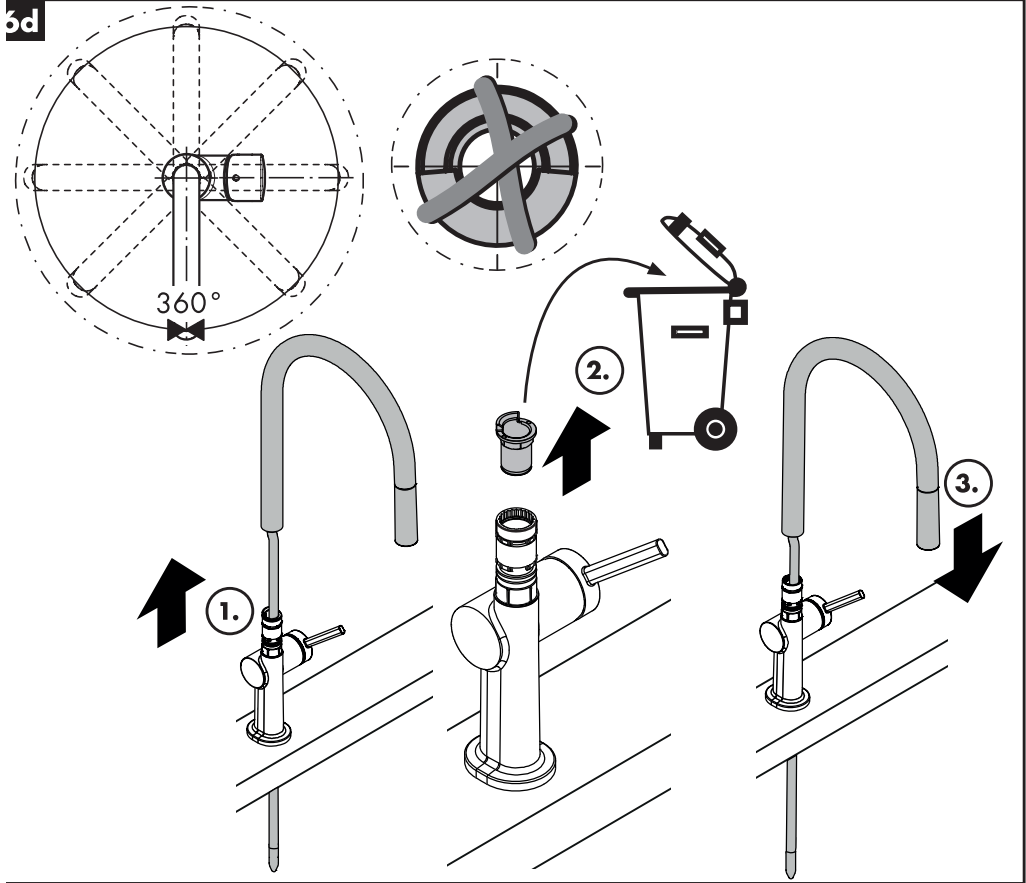

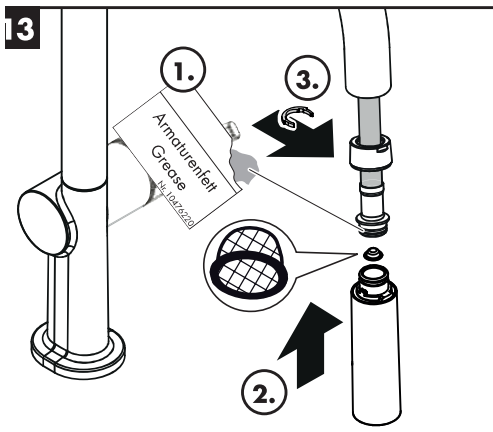
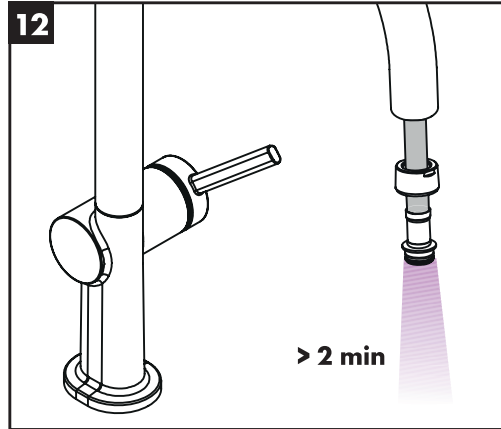
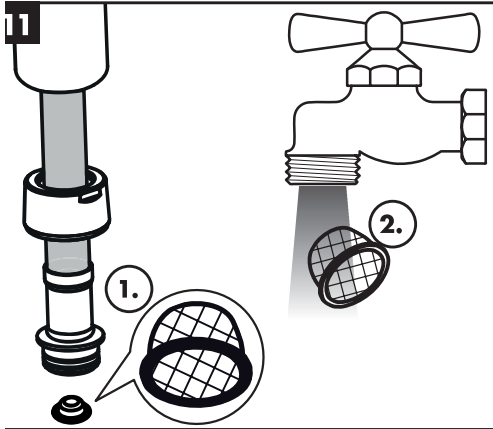
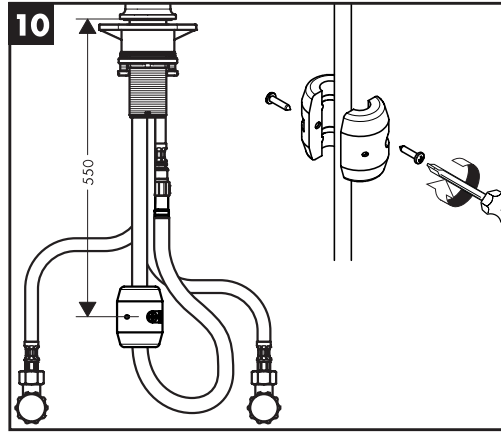
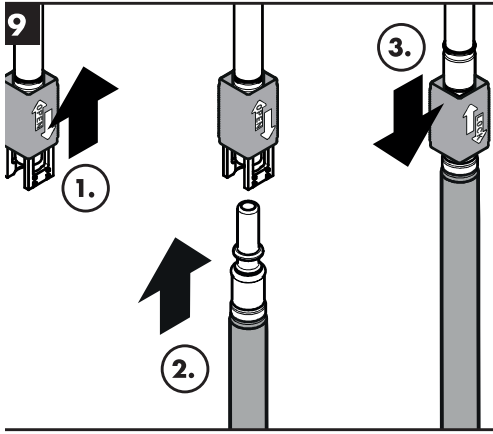

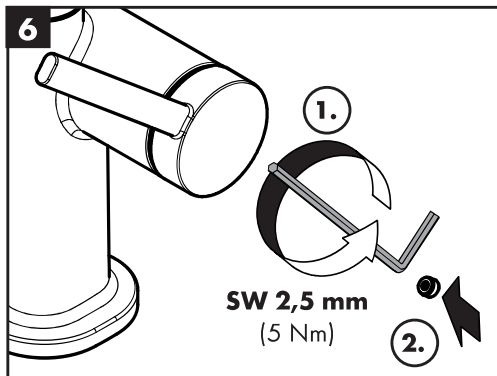
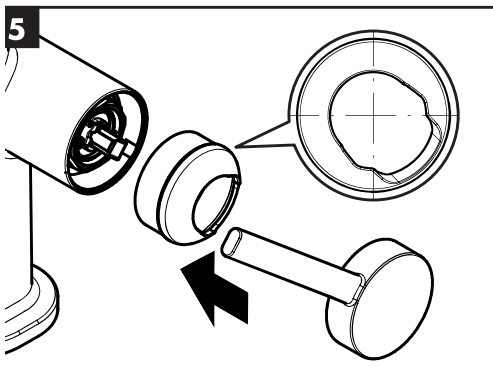
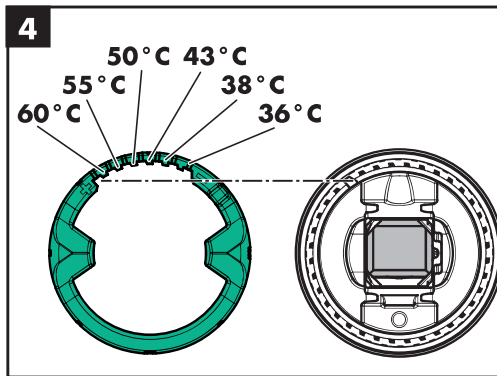
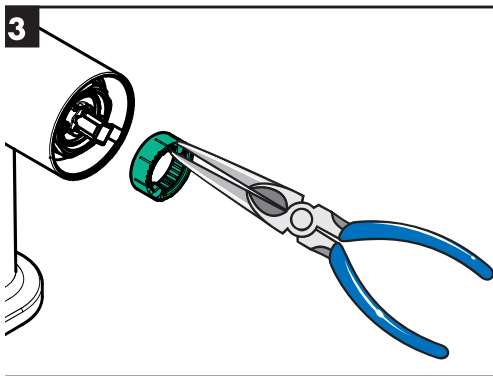
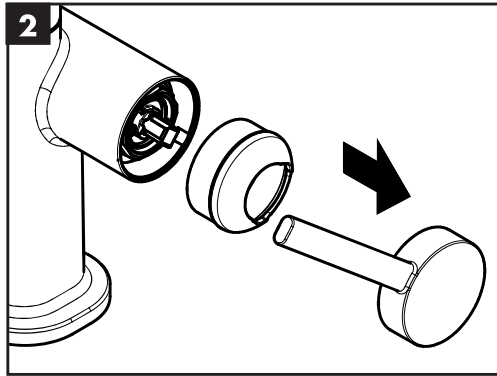
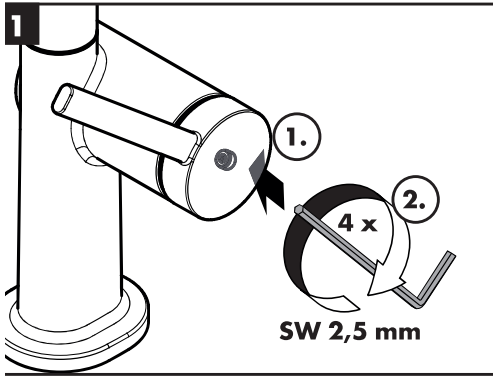

Talis M54 210 2jet
72800XXX

Talis M54 210 Eco 2jet
72842XXX

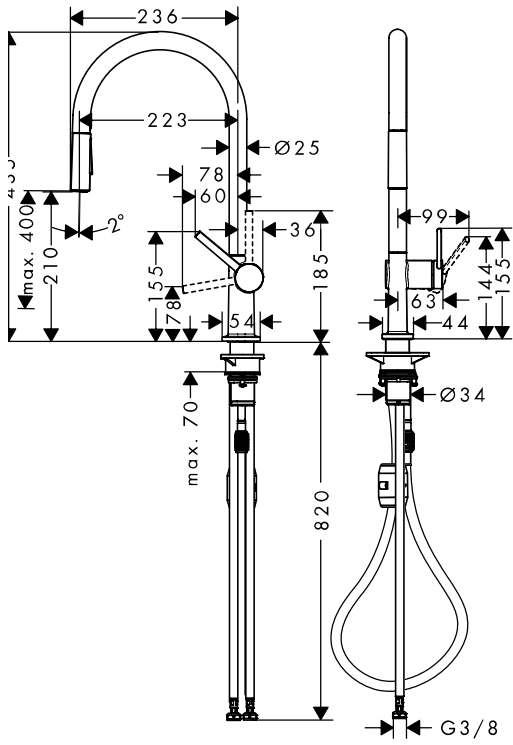

Talis M54 210 2jet
72800XXX

Talis M54 210 Eco 2jet
72842XXX

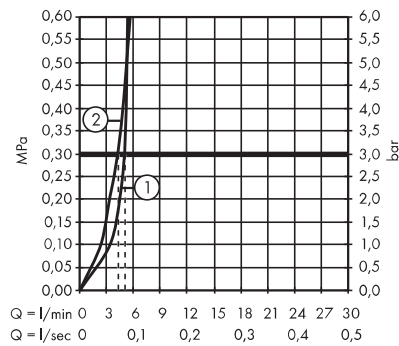
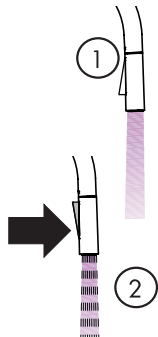
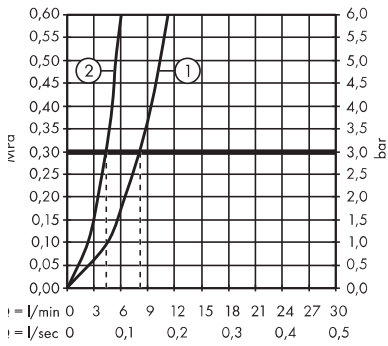



alis M54 210 1jet
 '2802XXX

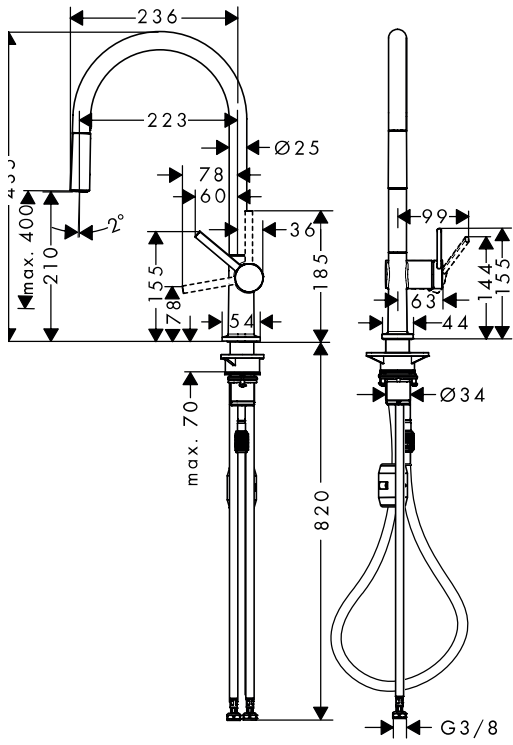

alis M54 210 1jet
 '2802XXX

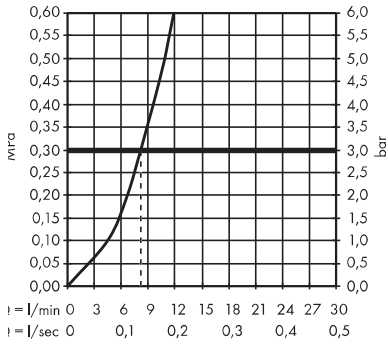



Talis M54 270 1jet

72808XXX

Talis M54 270 Eco 1jet

72845XXX

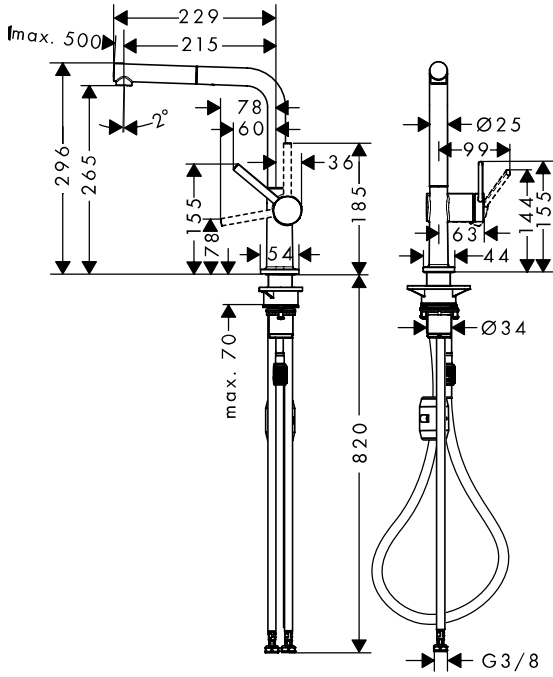

Talis M54 270 1jet

72808XXX

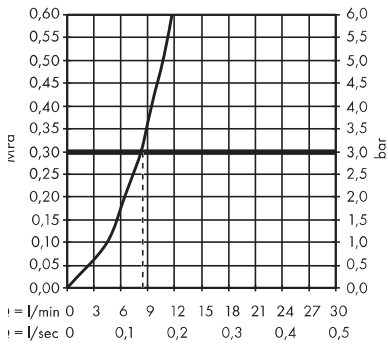

Talis M54 270 Eco 1jet

72845XXX

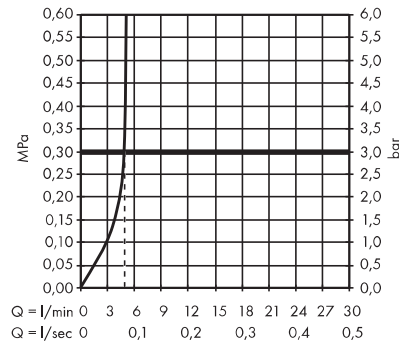



- DE** Reinigungsempfehlung / Garantie / Kontakt
- R** Recommandation pour le nettoyage / Garanties / Contact
- N** Cleaning recommendation / Warranty / Contact
- I** Raccomandazione di pulizia / Garanzia / Contatto
- S** Recomendaciones para la limpieza / Garantía / Contacto
- NL** Aanbevelingen inzake reiniging / Garantie / Contact
- DK** Rensning, anbefaling / Garanti / Kontakt
- PT** Recomendações de limpeza / Garantia / Contacto
- PL** Zalecenie dotyczące pielęgnacji / Gwarancja / Kontakt
- CS** Doporučení k čištění / Záruka / Kontakt
- SK** Odporúčania pre čistenie / Záruka / Kontakt
- H** 清洁指南 / 担保 / 接触
- RU** Рекомендации по очистке / Гарантия / Контакты
- F** Puhdistussuositus / Takuu / Kosketus
- V** Rengöringsrekommendationer / Garanti / Contacto
- LT** Valymo rekomendacijos / Garantija / Kontaktai
- HR** Preporuke za čišćenje / Garancija / Kontakt
- R** Temizleme önerisi / Garanti / Temas
- RO** Recomandări pentru curățare / Garanție / Contact
- EL** Σύσταση καθαρισμού / Εγγύηση / επαφή
- IL** Priporočilo za čiščenje / Garancija / Kontakt
- FI** Puhastussuositused / Garanti / Kontakt
- V** Tīrīšanas ieteikumi / Garantija / Kontakti
- R** Preporuke za čišćenje / Garancija / Kontakt
- NO** Anbefaling for rengjøring / Garanti / Kontakt
- G** Препоръка за почистване / Гаранция / Контакт
- Q** Këshilla rreth pastrimit / Garancia / Kontakt
- KR** 세정시 권장사항 / 품질보증 / 접촉
- AR** توصيات التنظيف / الضمان (الولايات المتحدة الأمريكية) / اتصال
- U** Tisztítási tanácsok / Garancia / érintkezés
- P** お手入れの方法 / 保証について / ご連絡先



www.hansgrohe.com/cleaning-recommendation

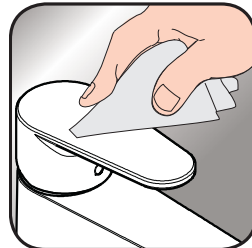

www.hansgrohe.com/cleaning-recommendation



www.hansgrohe.com/cleaning-recommendation



www.hansgrohe.com/cleaning-recommendation

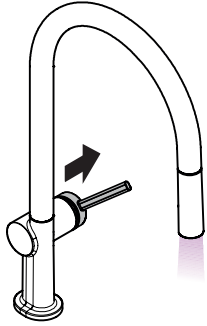

ffnen / ouvert / open / aperto / abierto / open /
 bne / abrir / otworzyć / otevřít / otvorit / 开 /
 ткрыть / nyitás / avaaminen / öppna / atidaryti /
 ὀnaranje / açmak / deschide / ανοικτό / odpreti /
 vage / atvērt / otvoriti / åpne / отваряне / hare /
 开 / 開く

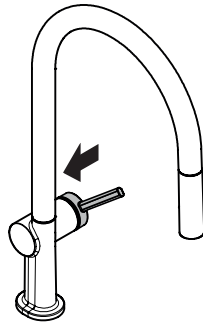

schließen / fermé / close / chiudere / cerrar / sluiten /
 lukke / fechar / zamknąć / zavřít / uzavrieť / 关 /
 закрыть / bezárás / sulkeminen / stänga / uždaryti /
 Zatvaranje / kapatmak / închide / κλειστό / zapreti /
 sulgege / aizvērt / zatvori / lukke / затваряне /
 mbylle / إغلاق / 閉じる

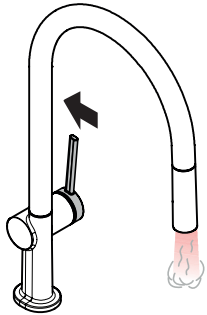

varm / chaud / hot / caldo / caliente / varm / varmt /
 uente / ciepła / teplá / teplá / 热 / горячая / meleg /
 žmmin / varmt / karštas / Vruća voda / sıcak / cald /
 εστό / toplo / kuum / karsts / topla / varm / тепло /
 ngrohtë / ساخن / 温かい

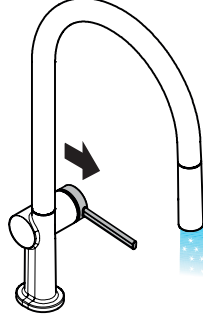

kalt / froid / cold / freddo / frío / koud / koldt / fria /
 zimna / studená / studená / 冷 / холодная / hideg /
 kylmä / kallt / šaltas / Hladno / soğuk / гесе / κρύο /
 mrzlo / külm / auksts / hladno / kaldt / студено /
 i ftohtë / بارد / 冷たい

alis M54 210 2jet
 *2800XXX

alis M54 210 Eco 2jet
 *2842XXX

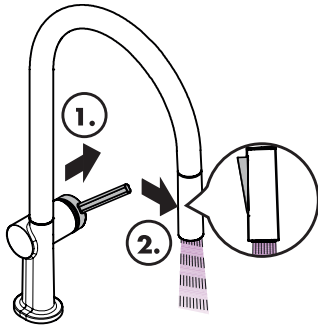

'alis M54 210 2jet

'2800XXX

'alis M54 210 Eco 2jet

'2842XXX

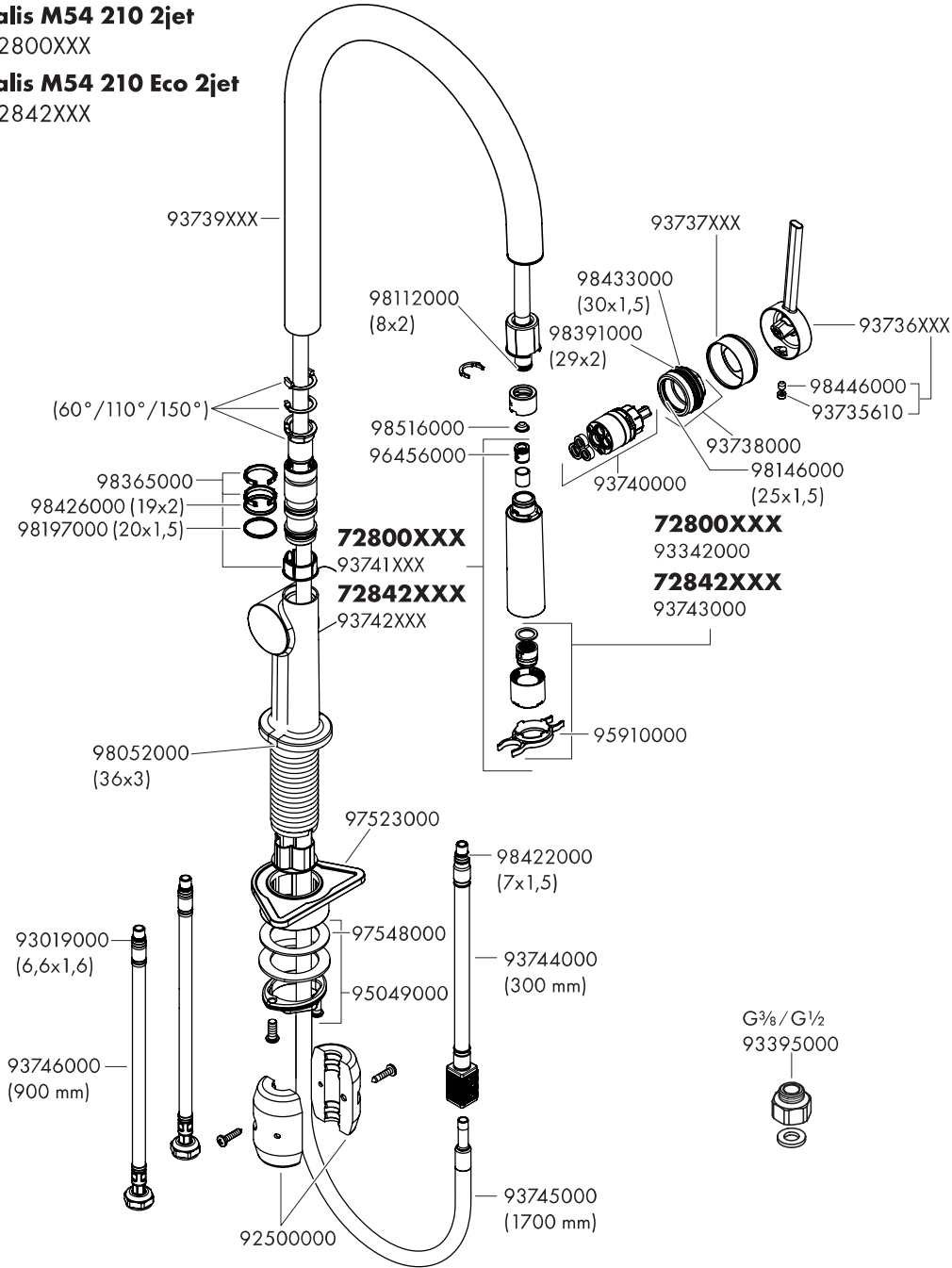



alis M54 210 1jet
2802XXX

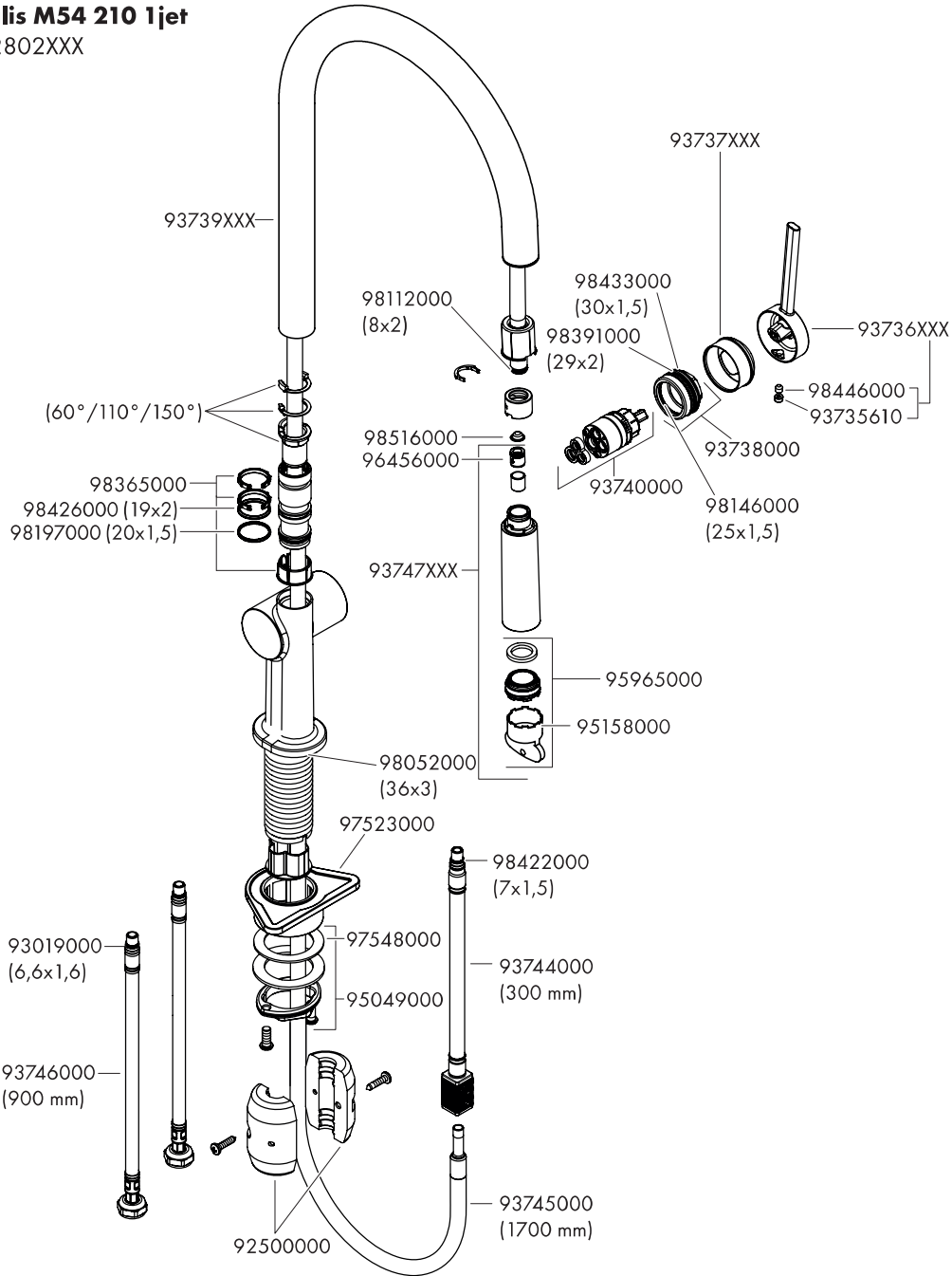



alis M54 270 1jet

72808XXX

alis M54 270 Eco 1jet

72845XXX

