



YTELSESERKLÆRING

No: DoP-230234 [NO]

ESSVE
GET IT DONE

Varetypens unike identifikasjonskode:

ESSVE Angle Brackets

Produsent :

ESSVE Produkter AB

BOX 7091

164 07 Kista

Sweden

Europeisk teknisk bedømmelse (ETA)	Tilsiktet bruksområde
ETA-23/0234 (2023-04-24)	o ETA-23/0234, section 2

Europeisk teknisk bedømmelse (ETA)	System for vurdering og verifikasjon av byggevarers ytelser (AVCP)	Europeisk bedømmelsesdokument	Teknisk bedømmelsesorgan (TAB)
ETA-23/0234 (2023-04-24)	2+	EAD 130186-00-0603, (2018-07)	ETA-Danmark A/S

Europeisk teknisk bedømmelse (ETA)	Egenskap	Ytelse
ETA-23/0234 (2023-04-24)	Joint Strength - Characteristic load-carrying capacity	Annex B
	Joint stiffness	Annex B
	Joint ductility	No performance assessed
	Resistance to seismic actions	No performance assessed
	Resistance to corrosion and deterioration	section 3.6
	Reaction to fire	Class A1



YTELSESERKLÆRING

No: DoP-230234 [NO]

ESSVE
GET IT DONE

Ytelser for denne byggevaren som er anført ovenfor, er i overensstemmelse med de angitte ytelsene. Denne ytelseserklæringen er utarbeidet i overensstemmelse med forordning (EU) nr. 305/2011 under produsentens eneansvar, som anført ovenfor.

Underskrevet for produsenten og på dennes vegne:

Dyar Jamil

Kista 2023-07-03

Dyar Jamil

Technical expert Wood fasteners

[ETA attached as an appendix]

Cross list:

Item no - ESSVE	ETA PRODUCT DESCRIPTION
452009	ANGLE BRACKET 50x50x35x2,5 CE
452045	ANGLE BRACKET 60x60x40x2,5 CE
452049	ANGLE BRACKET 60x60x60x2,5 CE
452015	ANGLE BRACKET 70x70x55x2,5 CE
452035	ANGLE BRACKET 80x80x60x2,5 CE
452037	ANGLE BRACKET 80x80x80x2,5 CE
452013	ANGLE BRACKET 90x90x40x3,0 CE
452005	ANGLE BRACKET 90x90x65x2,5 CE



ETA-Danmark A/S
Göteborg Plads 1
DK-2150 Nordhavn
Tel. +45 72 24 59 00
Fax +45 72 24 59 04
Internet www.etadanmark.dk

Authorised and notified according
to Article 29 of the Regulation (EU)
No 305/2011 of the European
Parliament and of the Council of 9
March 2011

MEMBER OF EOTA



European Technical Assessment ETA-23/0234 of 2023/04/24

I General Part

Technical Assessment Body issuing the ETA and designated according to Article 29 of the Regulation (EU) No 305/2011: ETA-Danmark A/S

Trade name of the construction product:

ESSVE angle brackets type 50x50x35x2,5;
60x60x40x2,5; 60x60x50x2,5; 60x60x60x2,5;
70x70x55x2,5; 70x70x55x2,5 (with rib);
80x80x60x2,5; 80x80x80x2,5; 90x90x40x3,0;
90x90x65x2,5; 90x90x65x2,5 (with rib);
100x100x80x2,5; 100x100x100x2,5

Product family to which the above construction product belongs:

Three-dimensional nailing plate (Angle brackets for timber-to-timber, timber-to-steel or timber-to-concrete connections)

Manufacturer:

ESSVE Produkter AB
Esbogatan 14
SE-164 74 Kista
Internet www.essve.se

Manufacturing plant:

ESSVE Produkter AB
Manufacturing plant 926

This European Technical Assessment contains:

20 pages including 2 annexes which form an integral part of the document

This European Technical Assessment is issued in accordance with Regulation (EU) No 305/2011, on the basis of:

EAD 130186-00-0603 for Three-dimensional nailing plates

This version replaces:

Translations of this European Technical Assessment in other languages shall fully correspond to the original issued document and should be identified as such.

Communication of this European Technical Assessment, including transmission by electronic means, shall be in full (excepted the confidential Annex(es) referred to above). However, partial reproduction may be made, with the written consent of the issuing Technical Assessment Body. Any partial reproduction has to be identified as such.

II SPECIFIC PART OF THE EUROPEAN TECHNICAL ASSESSMENT

1 Technical description of product

ESSVE angle brackets with and without rib are one-piece non-welded, face-fixed angle brackets to be used in timber to timber connections. They are connected to the timber elements by a range of profiled nails.

The angle brackets are made from pre-galvanized steel DX 51 D / Z 275 according to EN 10346:2015 with minimum yield strength $R_e \geq 250 \text{ N/mm}^2$, and minimum tensile strength $R_m \geq 360 \text{ N/mm}^2$ and minimum ultimate strain $A_{80} \geq 22\%$ and are available with or without an embossed rib. Dimensions, hole positions and typical installations are shown in Annex A. ESSVE angle brackets are made from steel with tolerances according to EN 10143.

2 Specification of the intended use in accordance with the applicable European Assessment Document (hereinafter EAD)

The angle brackets are intended for use in making connections in load bearing timber structures, as a connection between a beam and a purlin, where requirements for mechanical resistance and stability and safety in use in the sense of the Basic Works Requirements 1 and 4 of Regulation (EU) 305/2011 shall be fulfilled.

The connection may be with a single angle bracket or with an angle bracket on each side of the fastened timber member (see Annex A).

The static and kinematical behaviour of the timber members or the supports shall be as described in Annex B.

The wood members may be of solid timber, glued laminated timber and similar glued members, or wood-based structural members with a characteristic density from 290 kg/m^3 to 420 kg/m^3 . This requirement to the material of the wood members can be fulfilled by using the following materials:

- Structural solid timber classified to C14-C40 according to EN 338 / EN 14081,
- Glulam classified to GL24-GL36 according to EN 1194 / EN 14080,
- LVL according to EN 14374,
- Parallam PSL,
- Intrallam LSL,

- Duo- and Triobalken,
- Layered wood plates,
- Plywood according to EN 636

Annex B states the load-carrying capacities of the angle bracket connections for a characteristic density of 350 kg/m^3 . For timber or wood based material with a lower characteristic density than 350 kg/m^3 the load-carrying capacities shall be reduced by the k_{dens} factor:

$$k_{\text{dens}} = \left(\frac{\rho_k}{350} \right)^2$$

Where ρ_k is the characteristic density of the timber in kg/m^3 .

The design of the connections shall be in accordance with Eurocode 5 or a similar national Timber Code. The wood members shall have a thickness which is larger than the penetration depth of the nails into the members.

The angle brackets are primarily for use in timber structures subject to the dry, internal conditions defined by service classes 1 and 2 of Eurocode 5 and for connections subject to static or quasi-static loading.

The angle brackets can also be used in outdoor timber structures, service class 3, when a corrosion protection in accordance with Eurocode 5 is applied, or when stainless steel with similar or better characteristic yield and ultimate strength is employed.

The scope of the brackets regarding resistance to corrosion shall be defined according to national provisions that apply at the installation site considering environmental conditions.

The angle brackets may also be used for connections between a timber member and a member of concrete or steel.

The provisions made in this European Technical Assessment are based on an assumed intended working life of the connectors of 50 years.

The indications given on the working life cannot be interpreted as a guarantee given by the producer or Assessment Body, but are to be regarded only as a means for choosing the right products in relation to the expected economically reasonable working life of the works.

3 Performance of the product and references to the methods used for its assessment

Characteristic	Assessment of characteristic
3.1 Mechanical resistance and stability*) (BWR1)	
Joint Strength - Characteristic load-carrying capacity	See Annex B
Joint Stiffness	See Annex B
Joint ductility	No performance assessed
Resistance to seismic actions	No performance assessed
Resistance to corrosion and deterioration	See section 3.6
3.2 Safety in case of fire (BWR2)	
Reaction to fire	The angle brackets are made from steel classified as Euroclass A1 in accordance with EN 13501-1 and Commission Delegated Regulation 2016/364
3.3 General aspects related to the performance of the product	
Identification	See Annex A

*) See additional information in section 3.4 – 3.7.

3.4 Methods of verification

The characteristic load-carrying capacities are based on the characteristic values of the connectors and the steel plates.

According to EN 1990 (Eurocode – Basis of design) paragraph 6.3.5 the design value of load-carrying capacity can be determined by reducing the characteristic values of the load-carrying capacity with different partial factors.

Therefore, to obtain design values according to the Eurocodes or appropriate national codes of practice, the capacities have to be multiplied with different partial factors for the material properties and – for the connectors mounted in wood – also the coefficient k_{mod} that takes into account the load duration class.

Thus, the characteristic values of the load-carrying capacity are determined also for timber failure $F_{Rk,H}$ (obtaining the embedment strength of connectors subjected to shear or the withdrawal capacity of the most loaded connector, respectively) as well as for steel plate failure $F_{Rk,S}$. The design value of the load-carrying capacity is the smaller value of both load-carrying capacities.

$$F_{Rd} = \min \left\{ \frac{k_{mod} \cdot F_{Rk,H}}{\gamma_{M,H}}; \frac{F_{Rk,S}}{\gamma_{M,S}} \right\}$$

Therefore, for timber failure the load duration class and the service class are included. The different partial factors γ_M for steel or timber, respectively, are also correctly taken into account.

3.5 Mechanical resistance and stability

See annex B for the characteristic load-carrying capacity in the different directions F_1 to F_5 .

The characteristic capacities of the angle brackets are determined by calculation assisted by testing as described in the EAD 130186-00-0603. They should be used for designs in accordance with Eurocode 5 or a similar national Timber Code.

Threaded nails (ringed shank nails) in accordance to EN 14592

In the formulas in Annex B the capacities for threaded nails calculated from the formulas of Eurocode 5 are used assuming a thick steel plate when calculating the lateral nail load-carrying-capacity.

The load bearing capacities of the brackets has been determined based on the use of connector nails 4,0 x 40

mm in accordance with the German national approval for the nails.

The characteristic withdrawal capacity of the nails has to be determined by calculation in accordance with EN 1995-1-1: 2004, paragraph 8.3.2 (head pull-through is not relevant):

$$F_{ax,Rk} = f_{ax,k} \times d \times t_{pen}$$

Where:

$f_{ax,k}$	Characteristic value of the withdrawal parameter in N/mm^2
d	Nail diameter in mm
t_{pen}	Penetration depth of the profiles shank in mm
	$t_{pen} \geq 30$ mm

Based on tests by Versuchsanstalt für Stahl, Holz und Steine, University of Karlsruhe, the characteristic value of the withdrawal resistance for the threaded nails used can be calculated as:

$$f_{ax,k} = 50 \times 10^{-6} \times \sigma_k^2$$

Where:

σ_k	Characteristic density of the timber in kg/m^3
------------	--

The shape of the nail directly under the head shall be in the form of a truncated cone with a diameter under the nail head which exceeds the hole diameter.

4,0 mm threaded nails with a truncated cone below the head are used as fasteners, which are particularly suitable for nailed steel-to-timber connections. The specific shape below the head causes a clamping of nails in the steel plate.

It is assumed that angle brackets 70 with and without rib are fastened with nails 4,0x40 with a profiled length including the nail point of at least 30 mm and angle brackets 90 and 105 with and without rib are fastened with nails 4,0x60 with a profiled length including the nail point of at least 50 mm.

No performance has been determined in relation to ductility of a joint under cyclic testing. The contribution to the performance of structures in seismic zones, therefore, has not been assessed.

No performance has been determined in relation to the joint's stiffness properties - to be used for the analysis of the serviceability limit state.

3.6 Aspects related to the performance of the product

3.11.1 Corrosion protection in service class 1 and 2.
In accordance with EAD 130186-00-0603 the angle brackets are made from pre-galvanized steel are made from pre-galvanized steel DX 51 D / Z 275 according to EN 10346:2015.

3.7 General aspects related to the fitness for use of the product

ESSVE angle brackets are manufactured in accordance with the provisions of this European Technical Assessment using the manufacturing processes as identified in the inspection of the plant by the notified inspection body and laid down in the technical documentation.

The nailing pattern used shall be either the maximum or the minimum pattern as defined in Annex B.

The following provisions concerning installation apply:

There shall be nails or screws in all holes or at least in holes as specified on technical drawings in accordance with this document.

All minimum spacing's and edge/end distances in accordance with Eurocode 5 or an appropriate national code shall be complied with.

The angle bracket connection shall be designed in accordance with Eurocode 5 or an appropriate national code.

The cross section of the connected wooden elements shall have a plane surface against the whole angle bracket.

Nails or screws to be used shall have a diameter which fits the holes of the angle brackets.

The structural members – the components 1 and 2 - to which the brackets are fixed shall be:

- Restrained against rotation. At a load F_4/F_5 , the component 2 is allowed to be restrained against rotation by the Angle brackets.
- Strength class C14 or better, see section 1 of this ETA
- Free from wane under the bracket.
- The actual end bearing capacity of the timber member to be used in conjunction with the bracket is checked by the designer of the structure to ensure it is not less than the bracket capacity and, if

necessary, the bracket capacity reduced accordingly.

- The gap between the timber members does not exceed 3 mm.
- There are no specific requirements relating to preparation of the timber members.

4 Attestation and verification of constancy of performance (AVCP)

4.1 AVCP system

According to the decision 97/638/EC of the European Commission¹, as amended, the system(s) of assessment and verification of constancy of performance (see Annex V to Regulation (EU) No 305/2011) is 2+.

5 Technical details necessary for the implementation of the AVCP system, as foreseen in the applicable EAD

Technical details necessary for the implementation of the AVCP system are laid down in the control plan deposited at ETA-Danmark prior to CE marking.

Issued in Copenhagen on 2023-04-24 by



Thomas Bruun
Managing Director, ETA-Danmark

Annex A
Product details definitions

Table A.1 Materials specification

Bracket type	Thickness (mm)	Steel specification	Coating specification
50 x 50 x 35 x 2,5	2,5	DX 51 D	Z 275
60 x 60 x 40 x 2,5	2,5	DX 51 D	Z 275
60 x 60 x 50 x 2,5	2,5	DX 51 D	Z 275
60 x 60 x 60 x 2,5	2,5	DX 51 D	Z 275
70 x 70 x 55 x 2,5	2,5	DX 51 D	Z 275
70 x 70 x 55 x 2,5 (with rib)	2,5	DX 51 D	Z 275
80 x 80 x 60 x 2,5	2,5	DX 51 D	Z 275
80 x 80 x 80 x 2,5	2,5	DX 51 D	Z 275
90 x 90 x 40 x 3,0	3,0	DX 51 D	Z 275
90 x 90 x 65 x 2,5	2,5	DX 51 D	Z 275
90 x 90 x 65 x 2,5 (with rib)	2,5	DX 51 D	Z 275
100 x 100 x 80 x 2,5	2,5	DX 51 D	Z 275
100 x 100 x 100 x 2,5	2,5	DX 51 D	Z 275

Table A.2 Range of sizes

Bracket type	Height (mm)		Height (mm)		Width (mm)	
	vertical		horizontal			
50 x 50 x 35 x 2,5	47,5	50,5	47,5	50,5	34,0	36,0
60 x 60 x 40 x 2,5	59,0	61,0	59,0	61,0	39,0	41,0
60 x 60 x 50 x 2,5	58,0	61,0	58,0	61,0	49,0	51,0
60 x 60 x 60 x 2,5	59,0	61,0	59,0	61,0	59,0	62,0
70 x 70 x 55 x 2,5	69,5	72,5	69,5	72,5	54,0	56,0
70 x 70 x 55 x 2,5 (with rib)	70,0	73,0	70,0	73,0	54,0	56,0
80 x 80 x 60 x 2,5	79,0	81,0	79,0	81,0	59,0	61,0
80 x 80 x 80 x 2,5	79,0	81,0	79,0	81,0	79,0	81,0
90 x 90 x 40 x 3,0	88,0	91,0	88,0	91,0	37,0	41,0
90 x 90 x 65 x 2,5	88,0	91,0	88,0	91,0	64,0	66,0
90 x 90 x 65 x 2,5 (with rib)	88,0	91,0	88,0	91,0	62,0	66,0
100 x 100 x 80 x 2,5	97,5	100,5	97,5	100,5	79,0	81,0
100 x 100 x 100 x 2,5	97,5	100,5	97,5	100,5	99,0	101,0

Table A.3 Fastener specification

Nail type	Nail size (mm)		Finish
According to EN 14592	Diameter	Length	
Threaded nail	4,0	40	Electroplated zinc
<p>In the load-carrying-capacities of the nailed connection in Annex B the capacities for threaded nails calculated from the formulas of Eurocode 5 are used assuming a thick steel plate when calculating the lateral nail load-carrying-capacity.</p> <p>The load-carrying-capacities of the angle brackets have been determined based on the use of connector nails 4,0 x 40 mm in accordance with the German national approval for the nails.</p> <p>The characteristic withdrawal capacity of the nails has to be determined by calculation in accordance with EN 1995-1-1:2004, paragraph 8.3.2 (head pull-through is not relevant):</p> $F_{ax,Rk} = f_{ax,k} \times d \times t_{pen}$ <p>Where:</p> <p>$f_{ax,k}$ Characteristic value of the withdrawal parameter in N/mm²</p> <p>d Nail diameter in mm</p> <p>t_{pen} Penetration depth of the profiled shank including the nail point in mm, $t_{pen} \geq 31$ mm</p> <p>Based on tests by Versuchsanstalt für Stahl, Holz und Steine, University of Karlsruhe (KIT), the characteristic value of the withdrawal resistance for the threaded nails used can be calculated as:</p> $f_{ax,k} = 50 \times 10^{-6} \times \rho_k^2$ <p>Where:</p> <p>ρ_k Characteristic density of the timber in kg/m³</p> <p>The shape of the nail directly under the head shall be in the form of a truncated cone with a diameter under the nail head which exceeds the hole diameter.</p>			

ESSVE Angle Brackets

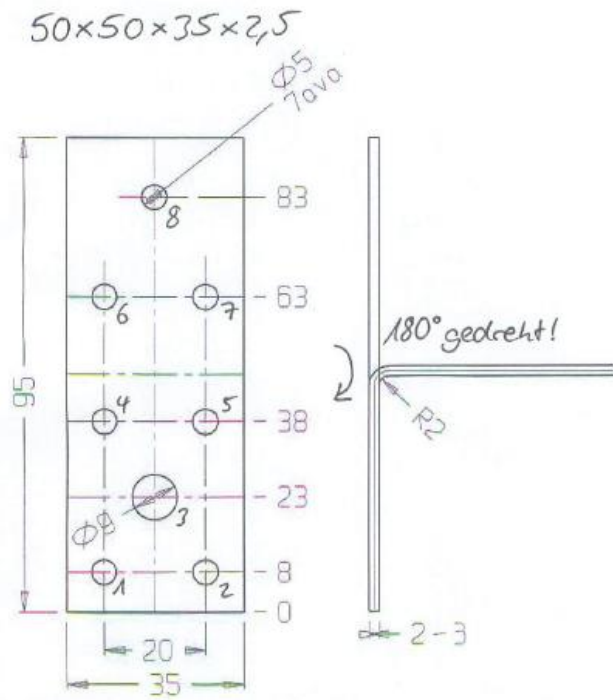

Figure A. 1 Dimensions of angle bracket 50x50x35x2,5

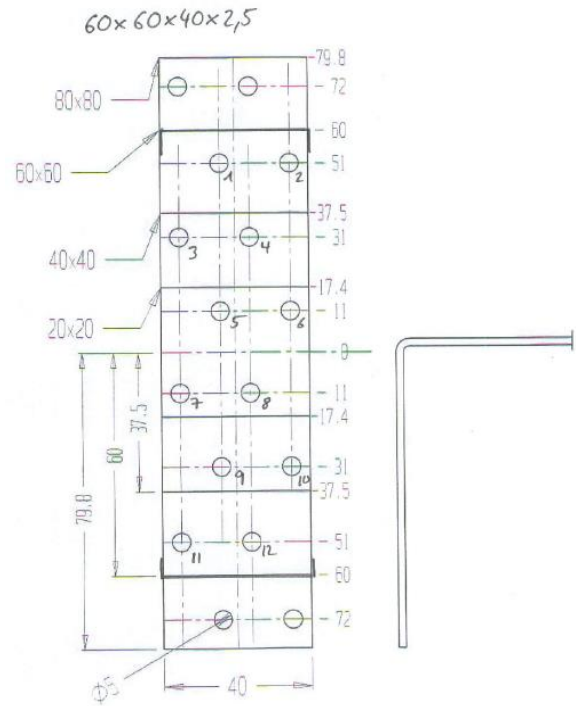

Figure A. 2 Dimensions of angle bracket 60x60x40x2,5

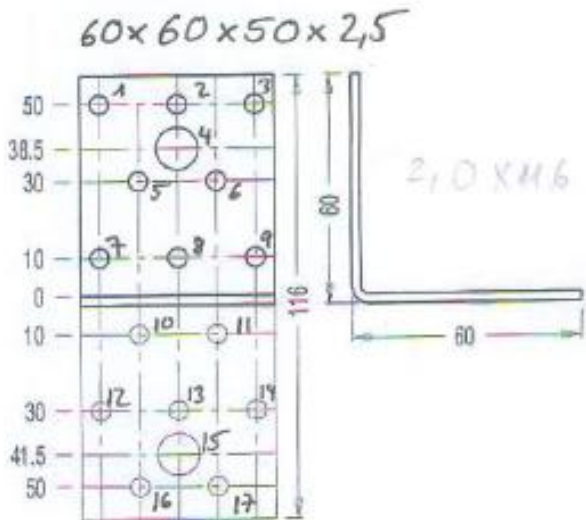

Figure A. 3 Dimensions of angle bracket 60x60x50x2,5

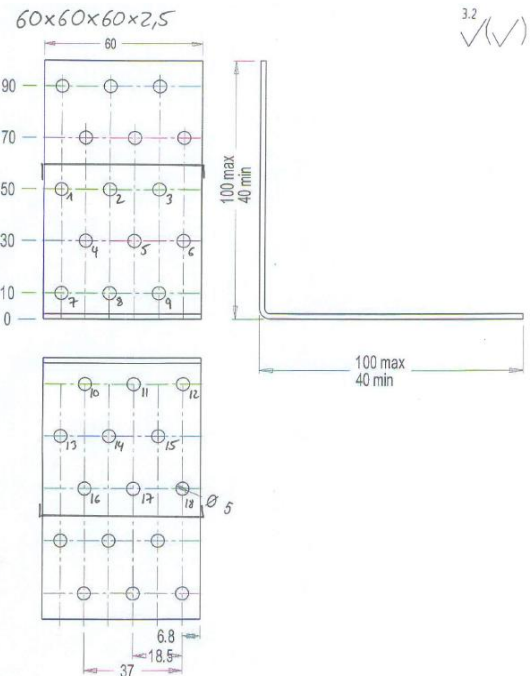

Figure A. 4 Dimensions of angle bracket 60x60x60x2,5

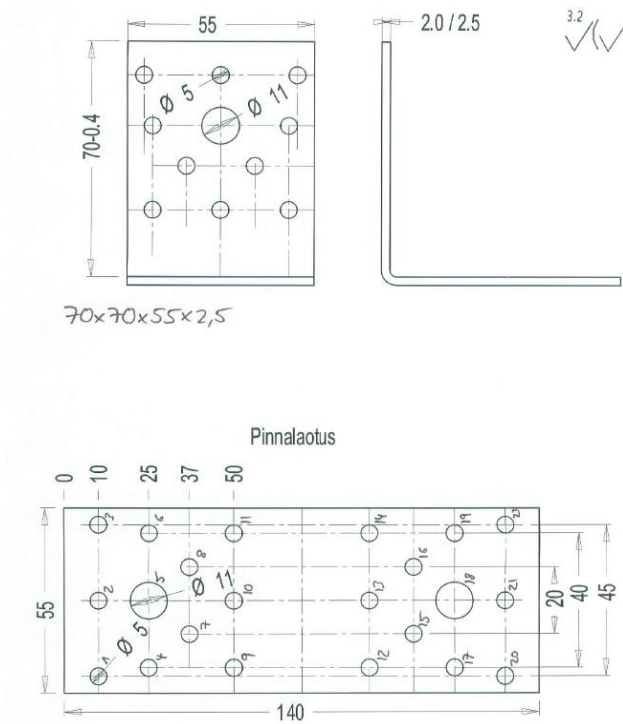

Figure A. 5 Dimensions of angle bracket 70x70x55x2,5

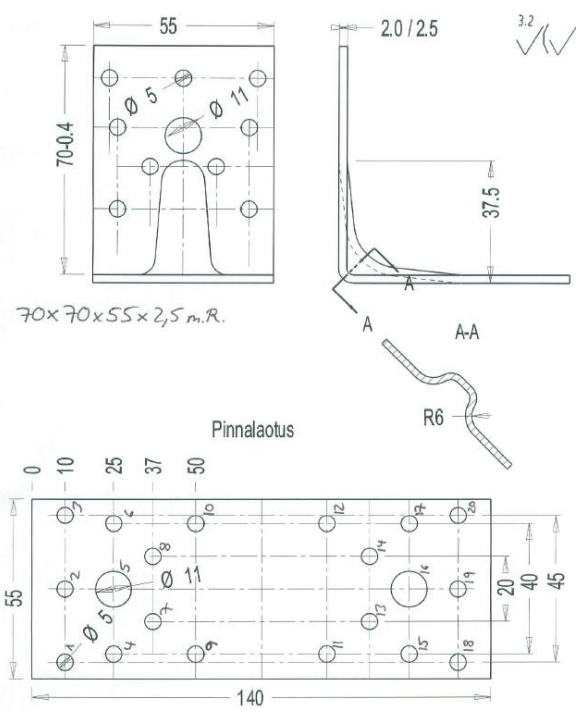

Figure A. 6 Dimensions of angle bracket 70x70x55x2,5 (with rib)

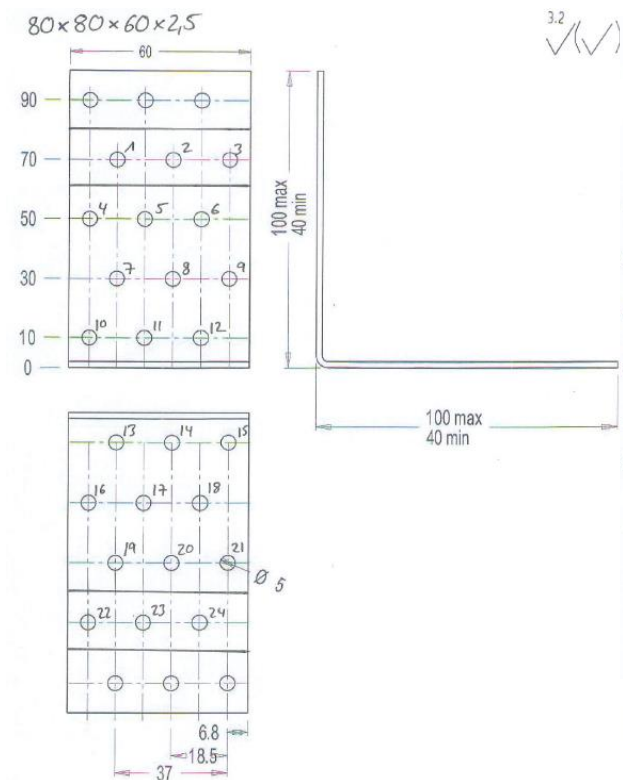

Figure A. 7 Dimensions of angle bracket 80x80x60x2,5

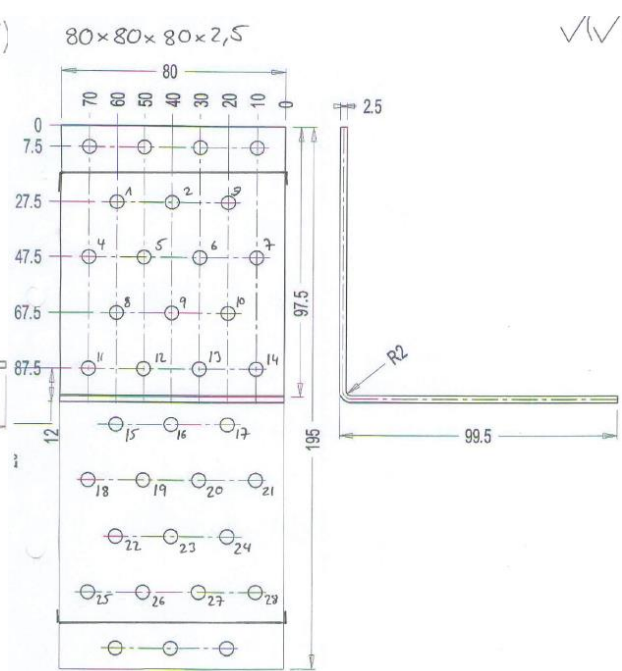

Figure A. 8 Dimensions of angle bracket 80x80x80x2,5

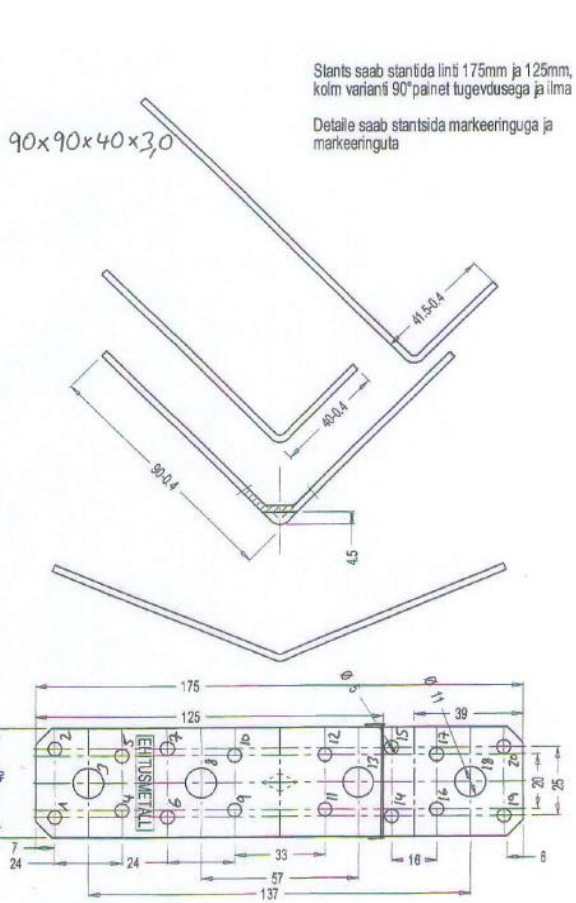

Figure A. 9 Dimensions of angle bracket 90x90x40x3,0

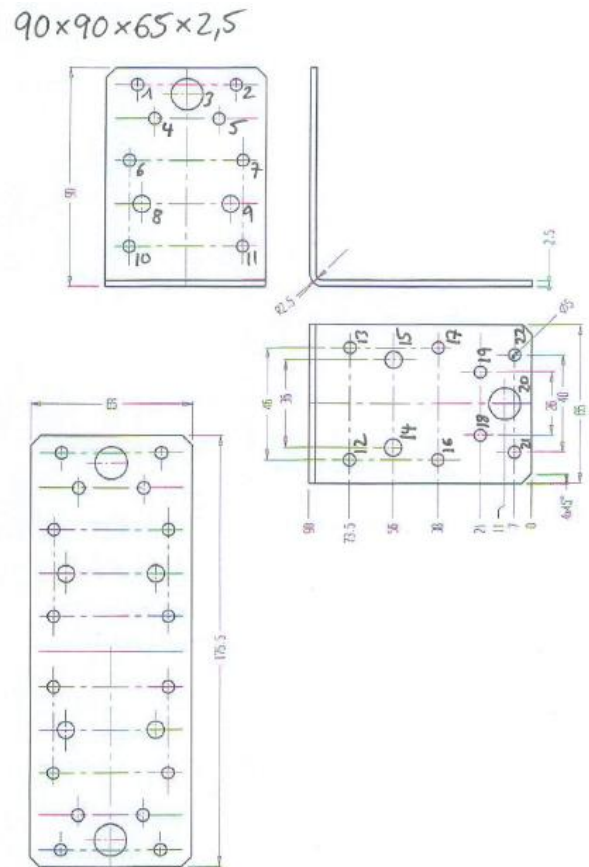

Figure A. 10 Dimensions of angle bracket 90x90x65x2,5

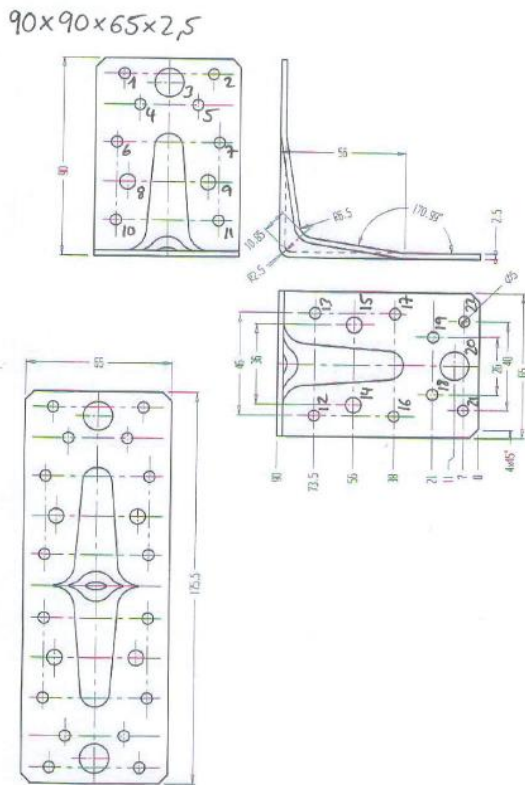

Figure A. 11 Dimensions of angle bracket 90x90x65x2,5 (with rib)

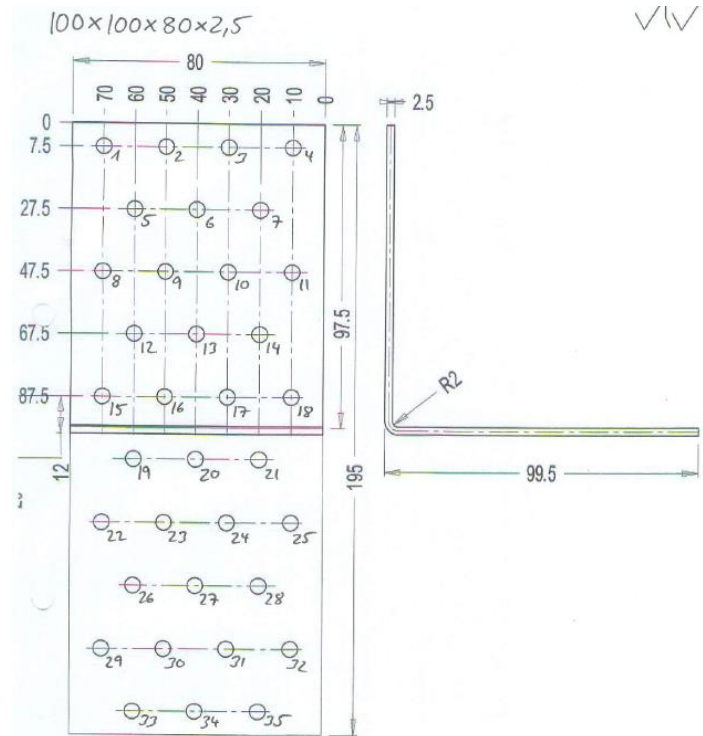

Figure A. 12 Dimensions of angle bracket 100x100x80x2,5

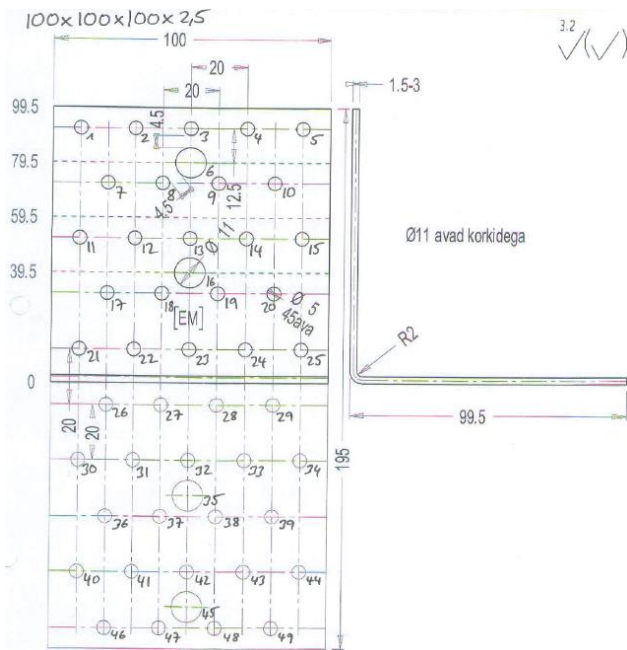

Figure A. 13 Dimensions of angle bracket 100x100x100x2,5

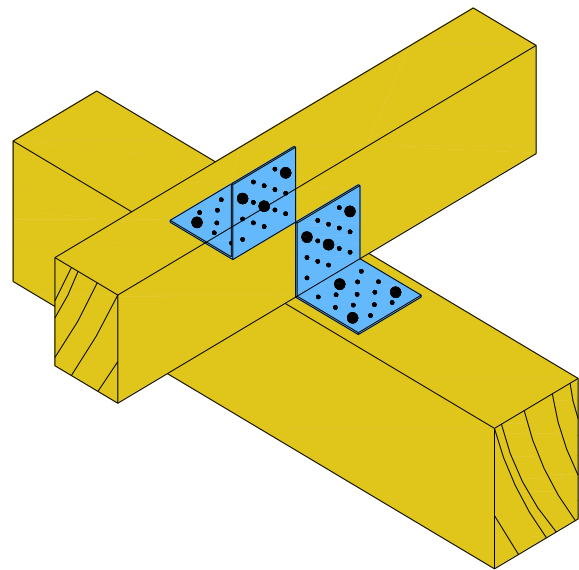

Figure A. 14 Typical installation

Annex B
Characteristic load-carrying capacities

Table 1: Force F_1 Column, 2 angle brackets / connection

Bracket type	Nail number n_V	Nail number n_H	$F_{1,Rk}$ [kN] (column)	
			Timber	Steel
50 x 50 x 35 x 2,5	-	-	-	-
60 x 60 x 40 x 2,5	-	-	-	-
60 x 60 x 50 x 2,5	-	-	-	-
60 x 60 x 60 x 2,5	-	-	-	-
70 x 70 x 55 x 2,5	1,2,3	12,13,14,15,16,20,21,22	3,05	1,81
70 x 70 x 55 x 2,5 with rib	1,2,3	11,12,13,14,18,19,20	2,04	2,40
80 x 80 x 60 x 2,5	1,2,3	13,14,15,16,17,18,19,20,21,22, 23,24	3,82	4,08
80 x 80 x 80 x 2,5	1,2,3	15,16,17,18,19,20,21,22,23,24, 25,26,27,28	3,68	4,71
90 x 90 x 40 x 3,0	1,2	11,12,14,15,19,20	2,35	2,37
90 x 90 x 65 x 2,5	1,2	12,13,16,17,21,22	2,37	3,02
90 x 90 x 65 x 2,5 with rib	1,2	12,13,16,17,21,22	2,37	9,76
100 x 100 x 80 x 2,5	1,2,3,4,5,6,7	19,20,21,22,23,24,25,26,27,28, 29,30,31,32,33,34,35	3,85	4,91
100 x 100 x 100 x 2,5	1,2,3,4,5,7,8,9,10	26,27,28,29,30,31,32,33,34,36, 37,38,39, 40,41,42,43,44,46,47,48,49	5,29	7,63

Table 2: Force F_1 Column, 1 angle bracket / connection

Bracket type	Nail number n_V	Nail number n_H	$F_{1,Rk}$ [kN] (column)	
			Timber	Steel
50 x 50 x 35 x 2,5	-	-	-	-
60 x 60 x 40 x 2,5	-	-	-	-
60 x 60 x 50 x 2,5	-	-	-	-
60 x 60 x 60 x 2,5	-	-	-	-
70 x 70 x 55 x 2,5	1,2,3	12,13,14,15,16,20,21,22	1,53	0,91
70 x 70 x 55 x 2,5 with rib	1,2,3	11,12,13,14,18,19,20	1,02	1,20
80 x 80 x 60 x 2,5	1,2,3	13,14,15,16,17,18,19,20,21,22, 23,24	1,91	2,04
80 x 80 x 80 x 2,5	1,2,3	15,16,17,18,19,20,21,22,23,24, 25,26,27,28	1,84	2,36
90 x 90 x 40 x 3,0	1,2	11,12,14,15,19,20	1,18	1,19
90 x 90 x 65 x 2,5	1,2	12,13,16,17,21,22	1,18	1,51
90 x 90 x 65 x 2,5 with rib	1,2	12,13,16,17,21,22	1,18	4,88
100 x 100 x 80 x 2,5	1,2,3,4,5,6,7	19,20,21,22,23,24,25,26,27,28, 29,30,31,32,33,34,35	1,93	2,45
100 x 100 x 100 x 2,5	1,2,3,4,5,7,8,9,10	26,27,28,29,30,31,32,33,34,36, 37,38,39, 40,41,42,43,44,46,47,48,49	2,64	3,82

Table 3: Force F_1 Purlin, 2 angle brackets / connection

Bracket type	Nail number n_V	Nail number n_H	$F_{1,Rk}$ [kN] (purlin)	
			Timber	Steel
50 x 50 x 35 x 2,5	1,2	6,7,8	1,87	1,46
60 x 60 x 40 x 2,5	1,2,3,4	7,8,9,10,11,12	2,35	2,47
60 x 60 x 50 x 2,5	1,2,3,5,6	10,11,12,13,14,16,17	2,41	3,63
60 x 60 x 60 x 2,5	1,2,3,4,5,6	10,11,12,13,14,15,16,17,18	3,61	4,08
70 x 70 x 55 x 2,5	1,2,3,7,8	12,13,14,15,16,20,21,22	3,05	1,81
70 x 70 x 55 x 2,5 with rib	1,2,3,7,8	11,12,13,18,15,19,20	2,04	2,40
80 x 80 x 60 x 2,5	1,2,3,4,5,6,7,8,9	13,14,15,16,17,18,19,20,21,22, 23,24	3,82	4,08
80 x 80 x 80 x 2,5	1,2,3,4,5,6,7,8,9,10	15,16,17,18,19,20,21,22,23,24, 25,26,27,28	3,68	4,71
90 x 90 x 40 x 3,0	1,2,4,5,6,7	11,12,14,15,19,20	2,35	2,37
90 x 90 x 65 x 2,5	1,2,4,5,6,7	12,13,16,17,21,22	2,37	3,02
90 x 90 x 65 x 2,5 with rib	1,2,4,5,6,7	12,13,16,17,21,22	2,37	9,76
100 x 100 x 80 x 2,5	1,2,3,4,5,6,7,8,9,10, 11,12,13,14	19,20,21,22,23,24,25,26,27,28, 29,30,31,32,33,34,35	3,85	4,91
100 x 100 x 100 x 2,5	1,2,3,4,5,7,8,9,10, 11,12,13,14,15,17, 18,19,20	26,27,28,29,30,31,32,33,34,36, 37,38,39, 40,41,42,43,44,46,47,48,49	5,29	7,63

Table 4: Force F_1 Purlin, 1 angle bracket / connection

Bracket type	Nail number n_V	Nail number n_H	$F_{1,Rk}$ [kN] (purlin)	
			Timber	Steel
50 x 50 x 35 x 2,5	1,2	6,7,8	0,93	0,73
60 x 60 x 40 x 2,5	1,2,3,4	7,8,9,10,11,12	1,18	1,24
60 x 60 x 50 x 2,5	1,2,3,5,6	10,11,12,13,14,16,17	1,20	1,81
60 x 60 x 60 x 2,5	1,2,3,4,5,6	10,11,12,13,14,15,16,17,18	1,80	2,04
70 x 70 x 55 x 2,5	1,2,3,7,8	12,13,14,15,16,20,21,22	1,53	0,91
70 x 70 x 55 x 2,5 with rib	1,2,3,7,8	11,12,13,18,15,19,20	1,02	1,20
80 x 80 x 60 x 2,5	1,2,3,4,5,6,7,8,9	13,14,15,16,17,18,19,20,21, 22,23,24	1,91	2,04
80 x 80 x 80 x 2,5	1,2,3,4,5,6,7,8,9,10	15,16,17,18,19,20,21,22,23, 24,25,26,27,28	1,84	2,36
90 x 90 x 40 x 3,0	1,2,4,5,6,7	11,12,14,15,19,20	1,18	1,19
90 x 90 x 65 x 2,5	1,2,4,5,6,7	12,13,16,17,21,22	1,18	1,51
90 x 90 x 65 x 2,5 with rib	1,2,4,5,6,7	12,13,16,17,21,22	1,18	4,88
100 x 100 x 80 x 2,5	1,2,3,4,5,6,7,8,9,10, 11,12,13,14	19,20,21,22,23,24,25,26,27, 28,29,30,31,32,33,34,35	1,93	2,45
100 x 100 x 100 x 2,5	1,2,3,4,5,7,8,9,10, 11,12,13,14,15,17, 18,19,20	26,27,28,29,30,31,32,33,34, 36,37,38,39, 40,41,42,43,44,46,47,48,49	2,64	3,82

Table 5: Forces $F_{2,3}$, 2 angle brackets / connection

Bracket type	Nail number n_V	Nail number n_H	$F_{2,3,Rk}$ [kN]
			Timber
50 x 50 x 35 x 2,5	1,2	6,7,8	2,07
60 x 60 x 40 x 2,5	1,2,3,4	7,8,9,10,11,12	4,24
60 x 60 x 50 x 2,5	1,2,3,5,6	10,11,12,13,14,16,17	5,33
60 x 60 x 60 x 2,5	1,2,3,4,5,6	10,11,12,13,14,15,16,17,18	7,58
70 x 70 x 55 x 2,5	1,2,3,7,8	12,13,14,15,16,20,21,22	5,71
70 x 70 x 55 x 2,5 with rib	1,2,3,7,8	11,12,13,18,15,19,20	5,56
80 x 80 x 60 x 2,5	1,2,3,4,5,6,7,8,9	13,14,15,16,17,18,19,20,21,22, 23,24	9,66
80 x 80 x 80 x 2,5	1,2,3,4,5,6,7,8,9,10	15,16,17,18,19,20,21,22,23,24, 25,26,27,28	11,4
90 x 90 x 40 x 3,0	1,2,4,5,6,7	11,12,14,15,19,20	5,06
90 x 90 x 65 x 2,5	1,2,4,5,6,7	12,13,16,17,21,22	5,89
90 x 90 x 65 x 2,5 with rib	1,2,4,5,6,7	12,13,16,17,21,22	5,89
100 x 100 x 80 x 2,5	1,2,3,4,5,6,7,8,9,10,1 1,12,13,14	19,20,21,22,23,24,25,26,27,28, 29,30,31,32,33,34,35	13,9
100 x 100 x 100 x 2,5	1,2,3,4,5,7,8,9,10, 11,12,13,14,15,17, 18,19,20	26,27,28,29,30,31,32,33,34,36, 37,38,39, 40,41,42,43,44,46,47,48,49	20,3

Table 6: Forces $F_{2,3}$, 1 angle bracket / connection

Bracket type	Nail number n_V	Nail number n_H	$F_{2,3,Rk}$ [kN]
			Timber
50 x 50 x 35 x 2,5	1,2	6,7,8	2,07
60 x 60 x 40 x 2,5	1,2,3,4	7,8,9,10,11,12	4,24
60 x 60 x 50 x 2,5	1,2,3,5,6	10,11,12,13,14,16,17	5,33
60 x 60 x 60 x 2,5	1,2,3,4,5,6	10,11,12,13,14,15,16,17,18	7,58
70 x 70 x 55 x 2,5	1,2,3,7,8	12,13,14,15,16,20,21,22	5,71
70 x 70 x 55 x 2,5 with rib	1,2,3,7,8	11,12,13,18,15,19,20	5,56
80 x 80 x 60 x 2,5	1,2,3,4,5,6,7,8,9	13,14,15,16,17,18,19,20,21, 22,23,24	9,66
80 x 80 x 80 x 2,5	1,2,3,4,5,6,7,8,9,10	15,16,17,18,19,20,21,22,23, 24,25,26,27,28	11,4
90 x 90 x 40 x 3,0	1,2,4,5,6,7	11,12,14,15,19,20	5,06
90 x 90 x 65 x 2,5	1,2,4,5,6,7	12,13,16,17,21,22	5,89
90 x 90 x 65 x 2,5 with rib	1,2,4,5,6,7	12,13,16,17,21,22	5,89
100 x 100 x 80 x 2,5	1,2,3,4,5,6,7,8,9,10,1 1,12,13,14	19,20,21,22,23,24,25,26,27, 28,29,30,31,32,33,34,35	13,9
100 x 100 x 100 x 2,5	1,2,3,4,5,7,8,9,10, 11,12,13,14,15,17, 18,19,20	26,27,28,29,30,31,32,33,34,36, 37,38,39, 40,41,42,43,44,46,47,48,49	10,1

Table 7: Basic Forces $F_{4,5}$, 2 angle brackets / connection

Bracket type	Nail number n_V	Nail number n_H	$F_{4,5,Rk}$ [kN]	
			Timber	Steel
50 x 50 x 35 x 2,5	1,2	6,7,8	5,38	2,24
60 x 60 x 40 x 2,5	1,2,3,4	7,8,9,10,11,12	5,08	2,81
60 x 60 x 50 x 2,5	1,2,3,5,6	10,11,12,13,14,16,17	5,56	3,62
60 x 60 x 60 x 2,5	1,2,3,4,5,6	10,11,12,13,14,15,16,17,18	7,40	4,11
70 x 70 x 55 x 2,5	1,2,3,7,8	12,13,14,15,16,20,21,22	5,92	4,27
70 x 70 x 55 x 2,5 with rib	1,2,3,7,8	11,12,13,18,15,19,20	5,85	5,43
80 x 80 x 60 x 2,5	1,2,3,4,5,6,7,8,9	13,14,15,16,17,18,19,20,21,22, 23,24	8,14	4,34
80 x 80 x 80 x 2,5	1,2,3,4,5,6,7,8,9,10	15,16,17,18,19,20,21,22,23,24, 25,26,27,28	9,81	6,01
90 x 90 x 40 x 3,0	1,2,4,5,6,7	11,12,14,15,19,20	5,44	2,99
90 x 90 x 65 x 2,5	1,2,4,5,6,7	12,13,16,17,21,22	8,52	4,45
90 x 90 x 65 x 2,5 with rib	1,2,4,5,6,7	12,13,16,17,21,22	8,55	7,96
100 x 100 x 80 x 2,5	1,2,3,4,5,6,7,8,9,10,11, 12,13,14	19,20,21,22,23,24,25,26,27,28, 29,30,31,32,33,34,35	10,7	5,88
100 x 100 x 100 x 2,5	1,2,3,4,5,7,8,9,10, 11,12,13,14,15,17, 18,19,20	26,27,28,29,30,31,32,33,34,36, 37,38,39, 40,41,42,43,44,46,47,48,49	12,5	7,33

Table 8: Basic Forces F_4 , 1 angle bracket / connection

Bracket type	Nail number n_V	Nail number n_H	$F_{4,Rk}$ [kN]	
			Timber	Steel
70 x 70 x 55 x 2,5 with rib	1,2,3,7,8	11,12,13,18,15,19,20	5,85	4,24
90 x 90 x 65 x 2,5 with rib	1,2,4,5,6,7	12,13,16,17,21,22	8,55	6,38

Table 9: Basic Forces F_5 , 1 angle bracket / connection

Bracket type	Nail number n_V	Nail number n_H	$F_{5,Rk}$ [kN]	
			Timber	Steel
70 x 70 x 55 x 2,5 with rib	1,2,3,7,8	11,12,13,18,15,19,20	1,28	1,40
90 x 90 x 65 x 2,5 with rib	1,2,4,5,6,7	12,13,16,17,21,22	1,70	1,73

Definitions of forces, their directions and eccentricity

Forces - Beam to beam connection

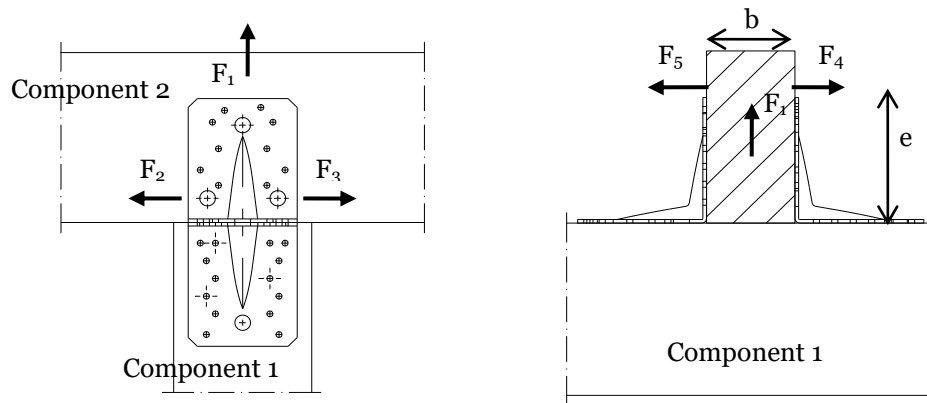

Fastener specification

Holes are marked with numbers referring to the nailing pattern in Annex A.

Double angle brackets per connection

The angle brackets must be placed at each side opposite to each other, symmetrically to the component axis.

Acting forces

- F_1 Lifting force acting along the central axis of the joint.
- F_2 and F_3 Lateral force acting in the joint between the component 2 and component 1 in the component 2 direction
- F_4 and F_5 Lateral force acting in the component 1 direction along the central axis of the joint. If the load is applied with an eccentricity e , a design for combined loading is required.

Single angle bracket per connection

Acting forces

- F_1 Lifting force acting in the central axis of the angle bracket. The component 2 shall be prevented from rotation. If the component 2 is prevented from rotation the load-carrying capacity will be half of a connection with double angle brackets.
- F_2 and F_3 Lateral force acting in the joint between the component 2 and the component 1 in the component 2 direction. The component 2 shall be prevented from rotation. If the component 2 is prevented from rotation the load-carrying capacity will be half of a connection with double angle brackets.
- F_4 and F_5 Lateral force acting in the component 1 direction in the height of the top edge of component 2. F_4 is the lateral force towards the angle bracket; F_5 is the lateral force away from the angle bracket. Only the characteristic load-carrying capacities for angle brackets with ribs are given.

Wane

Wane is not allowed, the timber has to be sharp-edged in the area of the angle brackets.

Timber splitting

For the lifting force F_1 it must be checked in accordance with Eurocode 5 or a similar national Timber Code that splitting will not occur.

Combined forces

If the forces F_1 and F_2/F_3 or F_4/F_5 act at the same time, the following inequality shall be fulfilled:

$$\left(\frac{F_{1,d}}{F_{Rd,1}} \right)^2 + \left(\frac{F_{2,d}}{F_{Rd,2}} \right)^2 + \left(\frac{F_{3,d}}{F_{Rd,3}} \right)^2 + \left(\frac{F_{4,d}}{F_{Rd,4}} \right)^2 + \left(\frac{F_{5,d}}{F_{Rd,5}} \right)^2 \leq 1$$

The forces F_2 and F_3 or F_4 and F_5 are forces with opposite direction. Therefore only one force F_2 or F_3 , and F_4 or F_5 , respectively, is able to act simultaneously with F_1 , while the other shall be set to zero.

If the load F_4/F_5 is applied with an eccentricity e , a design for combined loading **for connections with double angle brackets** is required. Here, an additional force ΔF_1 has to be added to the existing force F_1 .

$$\Delta F_{1,d} = F_{4,d} / F_{5,d} \cdot \frac{e}{B}$$

B is the width of component 2.