

ANGLE BRACKET



- | | |
|--|---|
| 1. Product type identification code | BB beam fastener
Dimensions: see ETA-09/0355 |
| 2. Type, batch, series numbers or other identification code | ETA-09/0355
Batch number: see label |
| 3. Intended use | Fasteners for supporting wooden structures, as well as for the fastening of beams and purlins in accordance with ETA-09/0355 |
| 4. Manufacturer contact address | BB Stanz- und Umformtechnik GmbH
Nordhäuser Str. 44
06536 Berga
Germany |
| 5. System of systems for durability assessment and testing | System 2+ |
| 6. Reference document | ETA-09/0355 |
| 7. Eota ref. / number | ETA-Danmark A/S, Nordhavn |
| 8. Conducted by the certification authority | - Initial inspection of the manufacturing plant and of factory production control
- Current monitoring, analysis and assessment of factory production control
- Result in conformity certificate
0769-CPD-6036 |
| 9. Declared performance | See ETA-09/0355 |
| 10. Product performance pursuant to item 1 and 2 corresponds to the declared performance pursuant to item 9. The manufacturer pursuant to item 4 is liable for this Performance Declaration. | |

Signed for the manufacturer and on behalf of the manufacturer by:

Fredrik Toth

Thomé Gruppen AB

Bjurögatan 28, Box 50304, SE-202 13 Malmö, Sweden

Phone: +46 40 38 60 00, Fax: +46 40 18 57 80,

E-mail: info@fast-fastening.com, www.fast-fastening.com



ETA-Danmark A/S
Göteborg Plads 1
DK-2150 Nordhavn
Tel. +45 72 24 59 00
Fax +45 72 24 59 04
Internet www.etadanmark.dk

Authorised and notified according
to Article 29 of the Regulation (EU)
No 305/2011 of the European
Parliament and of the Council of 9
March 2011

MEMBER OF EOTA



European Technical Assessment ETA-09/0355 of 2015-01-05

I General Part

Technical Assessment Body issuing the ETA and designated according to Article 29 of the Regulation (EU) No 305/2011: ETA-Danmark A/S

Trade name of the construction product:

BB Various Angle Brackets

Product family to which the above construction product belongs:

Three-dimensional nailing plate (Angle brackets for timber-to-timber or timber-to-concrete or steel connections)

Manufacturer:

BB Stanz- und Umformtechnik GmbH
Nordhäuser Str. 42
D-06536 Berga
Tel. +49 34651 2988 0
Fax +49 34651 2988 20
Internet www.bb-berga.de

Manufacturing plant:

BB Stanz- und Umformtechnik GmbH
Nordhäuser Str. 42
D-06536 Berga

This European Technical Assessment contains:

39 pages including 2 annexes which form an integral part of the document

This European Technical Assessment is issued in accordance with Regulation (EU) No 305/2011, on the basis of:

Guideline for European Technical Approval (ETAG) No. 015 Three Dimensional Nailing Plates, April 2013, used as European Assessment Document (EAD).

This version replaces:

The previous ETA with the same number issued on 2010-01-05 and expiry on 2015-01-05

Translations of this European Technical Assessment in other languages shall fully correspond to the original issued document and should be identified as such.

Communication of this European Technical Assessment, including transmission by electronic means, shall be in full (excepted the confidential Annex(es) referred to above). However, partial reproduction may be made, with the written consent of the issuing Technical Assessment Body. Any partial reproduction has to be identified as such.

II SPECIFIC PART OF THE EUROPEAN TECHNICAL ASSESSMENT

1 Technical description of product and intended use

Technical description of the product

The following types of brackets are covered by this ETA:

BB Stanz- und Umformtechnik Angle Brackets type 633 553 20, 633 753 20, 633 853 25, 631 460 25, 631 480 25, 631 640 25, 631 650 25, 631 660 25, 631 680 25, 631 610 25, 631 480 25, 631 860 25, 631 880 25, 631 810 25, 631 160 25, 631 180 25, 631 110 25, 631 554 20, 634 100 20, 634 150 20, 634 200 20, 641 035 25, 641 040 30, 641 664 30, 641 994 30, 641 595 30, 500 313 62, 641 598 30, 641 912 30, 641 690 25, 641 590 25, 641 490 25, 641 490 30, 651 554 25, 651 070 25, 651 994 25, 651 090 25, 651 105 30, 641 416 40, 631 460 20, 631 480 20, 631 610 20, 631 640 20, 631 650 20, 631 660 20, 631 680 20, 631 810 20, 631 480 20, 631 860 20, 631 880 20, 631 140 20, 631 160 20, 631 180 20, 631 110 20, RHV 60, RHV 80, 633 710 66.

BB angle brackets are one-piece non-welded, face-fixed angle brackets to be used in timber to timber or in timber to concrete or to steel connections. They are connected to construction members made of timber or wood-based products with profiled (ringed shank) nails or bolts according to EN 14592 and to concrete or steel members with bolts or metal anchors.

The angle brackets with a steel plate thickness of up to 6 mm are made from pre-galvanized steel S250 GD / Z 275 according to EN 10346:2009 with $R_e \geq 250 \text{ N/mm}^2$, $R_m \geq 330 \text{ N/mm}^2$ and $A_{80} \geq 19\%$.

Dimensions, hole positions and typical installations are shown in Annex A. BB angle brackets are made from steel with tolerances according to EN 10143.

2 Specification of the intended use in accordance with the applicable EAD

The angle brackets are intended for use in making connections in load bearing timber structures, as a connection between a beam and a purlin, where requirements for mechanical resistance and stability and safety in use in the sense of the Basic Works Requirements 1 and 4 of Regulation (EU) 305/2011 shall be fulfilled.

The connection may be with a single angle bracket or

with an angle bracket on each side of the fastened timber member (see Annex A).

The static and kinematic behaviour of the timber members or the supports shall be as described in Annex B.

The wood members can be of solid timber, glued laminated timber and similar glued members, or wood-based structural members with a characteristic density from 290 kg/m^3 to 420 kg/m^3 . This requirement to the material of the wood members can be fulfilled by using the following materials:

- Structural solid timber classified to C24-C40 according to EN 338 / EN 14081,
- Glulam classified to GL24-GL36 according to EN 1194 / EN 14080,
- LVL according to EN 14374,
- Parallam PSL,
- Intrallam LSL,
- Layered wood plates,
- Plywood according to EN 636

Annex B states the characteristic values of the load-carrying capacities of the angle bracket connections for a characteristic density of 350 kg/m^3 . For timber or wood based material with a lower characteristic density than 350 kg/m^3 the load-carrying capacities shall be reduced by the k_{dens} factor:

$$k_{\text{dens}} = \left(\frac{\rho_k}{350} \right)^2$$

Where ρ_k is the characteristic density of the timber in kg/m^3 .

The design of the connections shall be in accordance with Eurocode 5 or a similar national Timber Code. The wood members shall have a thickness, which is larger than the penetration depth of the nails into the members.

The angle brackets are primarily for use in timber structures subject to the dry, internal conditions defined by service class 1 and 2 of Eurocode 5 and for connections subject to static or quasi-static loading.

The angle brackets may also be used for connections between a timber member and a member of concrete or steel.

The scope of the brackets regarding resistance to corrosion shall be defined according to national provisions that apply at the installation site considering environmental conditions.

The provisions made in this European Technical Assessment are based on an assumed intended working life of the connectors of 50 years.

The indications given on the working life cannot be interpreted as a guarantee given by the producer or Assessment Body, but are to be regarded only as a means for choosing the right products in relation to the expected economically reasonable working life of the works.

3 Performance of the product and references to the methods used for its assessment

Characteristic	Assessment of characteristic
3.1 Mechanical resistance and stability*) (BWR1)	
Characteristic load-carrying capacity	See Annex B
Stiffness	No performance determined
Ductility in cyclic testing	No performance determined
3.2 Safety in case of fire (BWR2)	
Reaction to fire	The angle brackets are made from steel classified as Euroclass A1 in accordance with EN 1350-1 and EC decision 96/603/EC, amended by EC Decision 2000/605/EC
3.3 Hygiene, health and the environment (BWR3)	
Influence on air quality	The product does not contain/release dangerous substances specified in TR 034, dated March 2012 0**)
3.7 Sustainable use of natural resources (BWR7)	
	No Performance Determined
3.8 General aspects related to the performance of the product	
	The angle brackets have been assessed as having satisfactory durability and serviceability when used in timber structures using the timber species described in Eurocode 5 and subject to the conditions defined by service class 1 and 2
Identification	See Annex A

*) See additional information in section 3.8 – 3.9.

**) In addition to the specific clauses relating to dangerous substances contained in this European technical Assessment, there may be other requirements applicable to the products falling within its scope (e.g. transposed European legislation and national laws, regulations and administrative provisions). In order to meet the provisions of the Construction Products Regulation, these requirements need also to be complied with, when and where they apply.

3.9 Methods of verification

The characteristic load-carrying capacities are based on the characteristic values of the connectors and the steel plates.

According to EN 1990 (Eurocode – Basis of design) paragraph 6.3.5 the design value of load-carrying capacity can be determined by reducing the characteristic values of the load-carrying capacity with different partial factors.

Therefore, to obtain design values according to the Eurocodes or appropriate national codes of practice, the capacities have to be multiplied with different partial factors for the material properties and – for the connectors mounted in wood – also the coefficient k_{mod} that takes into account the load duration class.

Thus, the characteristic values of the load-carrying capacity are determined also for timber failure $F_{Rk,H}$ (obtaining the embedment strength of connectors subjected to shear or the withdrawal capacity of the most loaded connector, respectively) as well as for steel plate failure $F_{Rk,S}$. The design value of the load-carrying capacity is the smaller value of both load-carrying capacities.

$$F_{Rd} = \min \left\{ \frac{k_{mod} \cdot F_{Rk,H}}{\gamma_{M,H}}; \frac{F_{Rk,S}}{\gamma_{M,S}} \right\}$$

Therefore, for timber failure the load duration class and the service class are included. The different partial factors γ_M for steel or timber, respectively, are also correctly taken into account.

3.10 Mechanical resistance and stability

See annex B for the characteristic load-carrying capacity in the different directions F_1 to F_5 .

The characteristic capacities of the angle brackets are determined by calculation assisted by testing as described in the EOTA Guideline 015 clause 5.1.2. They should be used for designs in accordance with Eurocode 5 or a similar national Timber Code.

Threaded nails (ringed shank nails) in accordance to EN 14592

In the formulas in Annex B the capacities for threaded nails calculated from the formulas of Eurocode 5 are used assuming a thick steel plate when calculating the lateral nail load-carrying-capacity.

The characteristic withdrawal capacity of the nails has to be determined by calculation in accordance with EN

1995-1-1: 2004, paragraph 8.3.2 (head pull-through is not relevant):

$$F_{ax,Rk} = f_{ax,k} \times d \times t_{pen}$$

Where:

$f_{ax,k}$	Characteristic value of the withdrawal parameter in N/mm^2
d	Nail diameter in mm
t_{pen}	Penetration depth of the profiles shank in mm $t_{pen} \geq 31$ mm

Based on tests by Versuchsanstalt für Stahl, Holz und Steine, University of Karlsruhe, the characteristic value of the withdrawal resistance for the threaded nails used can be calculated as:

$$f_{ax,k} = 50 \times 10^{-6} \times \sigma_k^2$$

Where:

σ_k	Characteristic density of the timber in kg/m^3
------------	--

The shape of the nail directly under the head shall be in the form of a truncated cone with a diameter under the nail head which exceeds the hole diameter.

4,0 mm threaded nails with a truncated cone below the head are used as fasteners, which are particularly suitable for nailed steel-to-timber connections. The specific shape below the head causes a clamping of nails in the steel plate.

Additionally, the angle brackets can be fastened to the concrete structure or steel member by bolts with a diameter of 12 mm or 14 mm in holes with a diameter up to 2 mm larger than the bolt.

No performance has been determined in relation to ductility of a joint under cyclic testing. The contribution to the performance of structures in seismic zones, therefore, has not been assessed.

No performance has been determined in relation to the joint's stiffness properties - to be used for the analysis of the serviceability limit state.

3.11 Aspects related to the performance of the product

3.11.1 Corrosion protection in service class 1 and 2.

In accordance with ETAG 015 the angle brackets are made from pre-galvanized steel S 250 GD + Z275 according to EN 10346:2009

3.12 General aspects related to the fitness for use of the product

BB angle brackets are manufactured in accordance with the provisions of this European Technical Assessment using the manufacturing processes as identified in the inspection of the plant by the notified inspection body and laid down in the technical documentation.

The nailing pattern used shall be either the maximum or the minimum pattern as defined in Annex A.

The following provisions concerning installation apply:

There shall be nails or screws in all holes or at least in holes as specified on technical drawings in accordance with this document.

All minimum spacing's and edge/end distances in accordance with Eurocode 5 or an appropriate national code shall be complied with.

The angle bracket connection shall be designed in accordance with Eurocode 5 or an appropriate national code.

The cross section of the connected wooden elements shall have a plane surface against the whole angle bracket.

Nails or screws to be used shall have a diameter which fits the holes of the angle brackets.

The structural members – the components 1 and 2 - to which the brackets are fixed shall be:

- Restrained against rotation.
- Strength class C24 or better, see section 1 of this ETA
- Free from wane under the bracket.
- The actual end bearing capacity of the timber member to be used in conjunction with the bracket is checked by the designer of the structure to ensure it is not less than the bracket capacity and, if necessary, the bracket capacity reduced accordingly.
- The gap between the timber members does not exceed 3 mm.

- There are no specific requirements relating to preparation of the timber members.
- The execution of the connection shall be in accordance with the assessment holder's technical literature.

4 Attestation and verification of constancy of performance (AVCP)

4.1 AVCP system

According to the decision 97/638/EC of the European Commission¹, as amended, the system(s) of assessment and verification of constancy of performance (see Annex V to Regulation (EU) No 305/2011) is 2+.

5 Technical details necessary for the implementation of the AVCP system, as foreseen in the applicable EAD

Technical details necessary for the implementation of the AVCP system are laid down in the control plan deposited at ETA-Danmark

Issued in Copenhagen on 2015-01-05 by

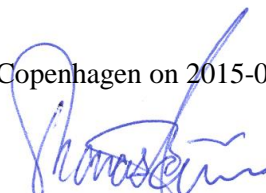

Thomas Bruun
Managing Director, ETA-Danmark

Annex A
Product details definitions

Table A.1 Materials specification

Bracket number	Bracket type	Thickness (mm)	Steel specification	Coating specification
633 553 20	50 x 50 x 30 x 2,0	2,0	S 250 GD	Z 275
633 753 20	70 x 50 x 30 x 2,0	2,0	S 250 GD	Z 275
633 853 25	80 x 50 x 30 x 2,5	2,5	S 250 GD	Z 275
631 460 25	40 x 40 x 60 x 2,5	2,5	S 250 GD	Z 275
631 480 25	40 x 40 x 80 x 2,5	2,5	S 250 GD	Z 275
631 640 25	60 x 60 x 40 x 2,5	2,5	S 250 GD	Z 275
631 650 25	60 x 60 x 50 x 2,5	2,5	S 250 GD	Z 275
631 660 25	60 x 60 x 60 x 2,5	2,5	S 250 GD	Z 275
631 680 25	60 x 60 x 80 x 2,5	2,5	S 250 GD	Z 275
631 610 25	60 x 60 x 100 x 2,5	2,5	S 250 GD	Z 275
631 480 25	80 x 80 x 40 x 2,5	2,5	S 250 GD	Z 275
631 860 25	80 x 80 x 60 x 2,5	2,5	S 250 GD	Z 275
631 880 25	80 x 80 x 80 x 2,5	2,5	S 250 GD	Z 275
631 810 25	80 x 80 x 100 x 2,5	2,5	S 250 GD	Z 275
631 160 25	100 x 100 x 60 x 2,5	2,5	S 250 GD	Z 275
631 180 25	100 x 100 x 80 x 2,5	2,5	S 250 GD	Z 275
631 110 25	100 x 100 x 100 x 2,5	2,5	S 250 GD	Z 275
631 554 20	50 x 50 x 40 x 2,0	2,0	S 250 GD	Z 275
634 100 20	40 x 40 x 100 x 2,0	2,0	S 250 GD	Z 275
634 150 20	40 x 40 x 150 x 2,0	2,0	S 250 GD	Z 275
634 200 20	40 x 40 x 200 x 2,0	2,0	S 250 GD	Z 275
641 035 25	50 x 50 x 35 x 2,5	2,5	S 250 GD	Z 275
641 040 30	50 x 50 x 40 x 3,0	3,0	S 250 GD	Z 275
641 664 30	60 x 60 x 45 x 3,0	3,0	S 250 GD	Z 275
641 994 30	90 x 90 x 40 x 3,0	3,0	S 250 GD	Z 275
641 595 30	90 x 50 x 50 x 3,0	3,0	S 250 GD	Z 275
500 313 62	90 x 50 x 116 x 3,0	3,0	S 250 GD	Z 275
641 598 30	90 x 48 x 76 x 3,0	3,0	S 250 GD	Z 275
641 912 30	120 x 90 x 40 x 3,0	3,0	S 250 GD	Z 275
641 690 25	90 x 60 x 60 x 2,5	2,5	S 250 GD	Z 275
641 590 25	90 x 50 x 50 x 2,5	2,5	S 250 GD	Z 275
641 490 25	90 x 40 x 40 x 2,5	2,5	S 250 GD	Z 275
641 490 30	90 x 40 x 40 x 3,0	3,0	S 250 GD	Z 275
651 554 25	50 x 50 x 40 x 2,5	2,5	S 250 GD	Z 275
651 070 25	70 x 70 x 55 x 2,5	2,5	S 250 GD	Z 275
651 994 25	90 x 90 x 40 x 2,5	2,5	S 250 GD	Z 275
651 090 25	90 x 90 x 65 x 2,5	2,5	S 250 GD	Z 275
651 105 30	105 x 105 x 90 x 3,0	3,0	S 250 GD	Z 275
641 416 40	160 x 50 x 40 x 3,0	3,0	S 250 GD	Z 275
631 460 20	40 x 40 x 60 x 2,0	2,0	S 250 GD	Z 275
631 480 20	40 x 40 x 80 x 2,0	2,0	S 250 GD	Z 275
631 610 20	60 x 60 x 100 x 2,0	2,0	S 250 GD	Z 275
631 640 20	60 x 60 x 40 x 2,0	2,0	S 250 GD	Z 275
631 650 20	60 x 60 x 50 x 2,0	2,0	S 250 GD	Z 275
631 660 20	60 x 60 x 60 x 2,0	2,0	S 250 GD	Z 275
631 680 20	60 x 60 x 80 x 2,0	2,0	S 250 GD	Z 275
631 810 20	80 x 80 x 100 x 2,0	2,0	S 250 GD	Z 275
631 480 20	80 x 80 x 40 x 2,0	2,0	S 250 GD	Z 275
631 860 20	80 x 80 x 60 x 2,0	2,0	S 250 GD	Z 275
631 880 20	80 x 80 x 80 x 2,0	2,0	S 250 GD	Z 275
631 140 20	100 x 100 x 40 x 2,0	2,0	S 250 GD	Z 275

631 160 20	100 x 100 x 60 x 2,5	2,5	S 250 GD	Z 275
631 180 20	100 x 100 x 80 x 2,0	2,0	S 250 GD	Z 275
631 110 20	100 x 100 x 100 x 2,0	2,0	S 250 GD	Z 275
RHV 60	80 x 80 x 60 x 1,5	1,5	S 250 GD	Z 275
RHV 80	120 x 120 x 75 x 1,5	1,5	S 250 GD	Z 275
633 710 66	100 x 75 x 60 x 6,0	6,0	S 250 GD	Z 275

Table A.2 Range of sizes

Bracket number	Bracket type	Height (mm)		Height (mm)		Width (mm)	
		vertical		horizontal			
633 553 20	50 x 50 x 30 x 2,0	51	53	51	53	29	31
633 753 20	70 x 50 x 30 x 2,0	71	73	51	53	29	31
633 853 25	80 x 50 x 30 x 2,5	81	83	51	53	29	31
631 460 25	40 x 40 x 60 x 2,5	39	41	39	41	59	61
631 480 25	40 x 40 x 80 x 2,5	41,5	43,5	41,5	43,5	79	81
631 640 25	60 x 60 x 40 x 2,5	59	61	59	61	39	41
631 650 25	60 x 60 x 50 x 2,5	61,5	63,5	61,5	63,5	49	51
631 660 25	60 x 60 x 60 x 2,5	59	61	59	61	59	61
631 680 25	60 x 60 x 80 x 2,5	59	61	59	61	79	81
631 610 25	60 x 60 x 100 x 2,5	61,5	63,5	61,5	63,5	99	101
631 480 25	80 x 80 x 40 x 2,5	79	81	79	81	39	41
631 860 25	80 x 80 x 60 x 2,5	81,5	83,5	81,5	83,5	59	61
631 880 25	80 x 80 x 80 x 2,5	81,5	83,5	81,5	83,5	79	81
631 810 25	80 x 80 x 100 x 2,5	79	81	79	81	99	101
631 160 25	100 x 100 x 60 x 2,5	99	101	99	101	59	61
631 180 25	100 x 100 x 80 x 2,5	99	101	99	101	79	81
631 110 25	100 x 100 x 100 x 2,5	99	101	99	101	99	101
631 554 20	50 x 50 x 40 x 2,0	49	51	49	51	39	41
634 100 20	40 x 40 x 100 x 2,0	39	41	39	41	99	101
634 150 20	40 x 40 x 150 x 2,0	41	43	41	43	149	151
634 200 20	40 x 40 x 200 x 2,0	41	43	41	43	199	201
641 035 25	50 x 50 x 35 x 2,5	49	51	49	51	34	36
641 040 30	50 x 50 x 40 x 3,0	49	51	49	51	39	41
641 664 30	60 x 60 x 45 x 3,0	59	61	59	61	44	46
641 994 30	90 x 90 x 40 x 3,0	89	91	89	91	39	41
641 595 30	90 x 50 x 50 x 3,0	92	94	51	53	50	52
500 313 62	90 x 50 x 116 x 3,0	89	91	49	51	115	117
641 598 30	90 x 48 x 76 x 3,0	89	91	47	49	75	77
641 912 30	120 x 90 x 40 x 3,0	122	124	92	94	39	41
641 690 25	90 x 60 x 60 x 2,5	89	91	59	61	59	61
641 590 25	90 x 50 x 50 x 2,5	91,5	93,5	50,5	52,5	50	52
641 490 25	90 x 40 x 40 x 2,5	82	84	41	43	39	41
641 490 30	90 x 40 x 40 x 3,0	82	84	41	43	39	41
651 554 25	50 x 50 x 40 x 2,5	49	51	49	51	39	41
651 070 25	70 x 70 x 55 x 2,5	69	71	69	71	54	56
651 994 25	90 x 90 x 40 x 2,5	89	91	89	91	39	41
651 090 25	90 x 90 x 65 x 2,5	89	91	89	91	64	66
651 105 30	105 x 105 x 90 x 3,0	104	106	104	106	89	91
641 416 40	160 x 50 x 40 x 3,0	165	167	49	51	39	41
631 460 20	40 x 40 x 60 x 2,0	39	41	39	41	59	61
631 480 20	40 x 40 x 80 x 2,0	39	41	39	41	79	81
631 610 20	60 x 60 x 100 x 2,0	59,5	61,5	59	61	99	101
631 640 20	60 x 60 x 40 x 2,0	59	61	59	61	39	41
631 650 20	60 x 60 x 50 x 2,0	59	61	59	61	49	51
631 660 20	60 x 60 x 60 x 2,0	59	61	59	61	59	61
631 680 20	60 x 60 x 80 x 2,0	59	61	59	61	79	81

631 810 20	80 x 80 x 100 x 2,0	79	81	79	81	99	101
631 480 20	80 x 80 x 40 x 2,0	79	81	79	81	39	41
631 860 20	80 x 80 x 60 x 2,0	79	81	79	81	59	61
631 880 20	80 x 80 x 80 x 2,0	79	81	79	81	79	81
631 140 20	100 x 100 x 40 x 2,0	101	103	101	103	39	41
631 160 20	100 x 100 x 60 x 2,5	102	104	102	104	59	61
631 180 20	100 x 100 x 80 x 2,0	99	101	99	101	79	81
631 110 20	100 x 100 x 100 x 2,0	99	101	99	101	99	101
RHV 60	80 x 80 x 60 x 1,5	79	81	79	81	56	58
RHV 80	120 x 120 x 75 x 1,5	122	124	122	124	73	75
633 710 66	100 x 75 x 60 x 6,0	102	104	70	72	59	61

Table A.3 Fastener specification

Nail type	Nail size (mm)		Finish
	Diameter	Length	
According to EN 14592			
Threaded nail	4,0	40	Electroplated zinc
<p>In the load-carrying-capacities of the nailed connection in Annex B the capacities for threaded nails calculated from the formulas of Eurocode 5 are used assuming a thick steel plate when calculating the lateral nail load-carrying-capacity.</p> <p>The load-carrying-capacities of the angle brackets have been determined based on the use of connector nails 4,0 x 40 mm in accordance with the German national approval for the nails.</p> <p>The characteristic withdrawal capacity of the nails has to be determined by calculation in accordance with EN 1995-1-1:2004, paragraph 8.3.2 (head pull-through is not relevant):</p> $F_{ax,Rk} = f_{ax,k} \times d \times t_{pen}$ <p>Where:</p> <p>$f_{ax,k}$ Characteristic value of the withdrawal parameter in N/mm²</p> <p>d Nail diameter in mm</p> <p>t_{pen} Penetration depth of the profiled shank including the nail point in mm, $t_{pen} \geq 30$ mm</p> <p>Based on tests by Versuchsanstalt für Stahl, Holz und Steine, University of Karlsruhe, the characteristic value of the withdrawal resistance for the threaded nails used can be calculated as:</p> $f_{ax,k} = 50 \times 10^{-6} \times \rho_k^2$ <p>Where:</p> <p>ρ_k Characteristic density of the timber in kg/m³</p> <p>The shape of the nail directly under the head shall be in the form of a truncated cone with a diameter under the nail head which exceeds the hole diameter.</p>			

BOLTS diameter	Correspondence Hole diameter	Bolts type
12.0 and 14.0	Max. 2 mm. larger than the bolt diameter	See specification of the manufacturer

METAL ANCHORS diameter	Correspondence Hole diameter	Anchors type
12.0 and 14.0	Max. 2 mm. larger than the anchor diameter	See specification of the manufacturer

Annex B: Characteristic load-carrying capacities**Table B.1:** Force F_1 Column, 2 angle brackets / connection

Bracket number	Bracket type	Nail number n_V	Nail number n_H	$F_{1,Rk}$ [kN] (column)	
				Timber	Steel
633 753 20	70 x 50 x 30 x 2,0	1,2	7,8	1,66	0,28
633 853 25	80 x 50 x 30 x 2,5	1,2	9,10	2,11	0,68
631 860 25	80 x 80 x 60 x 2,5	1,2,3	11,12,13,14,15,16,17,18,19,20	3,70	2,81
631 880 25	80 x 80 x 80 x 2,5	1,2,3,4	15,16,17,18,19,20,21,22,23,24,25,26,27,28	4,93	3,75
631 810 25	80 x 80 x 100 x 2,5	1,2,3,4	19,20,21,22,23,24,25,26,27,28,29,30,31,32,33,34,35,36	5,10	6,25
631 160 25	100 x 100 x 60 x 2,5	1,2,3,4,5	14,15,16,17,18,19,20,21,22,23,24,25	2,63	3,91
631 180 25	100 x 100 x 80 x 2,5	1,2,3,4,5,6,7	18,19,20,21,22,23,24,25,26,27,28,29,30,31,32,33,34,35	5,26	4,69
631 110 25	100 x 100 x 100 x 2,5	1,2,3,4,5,6,7,8,9	24,25,26,27,28,29,30,31,32,33,34,35,36,37,38,39,40,41,42,43,44,45	5,26	7,38
641 994 30	90 x 90 x 40 x 3,0	1,2	11,12,14,15,19,20	2,30	1,82
641 595 30	90 x 50 x 50 x 3,0	1,3,5,6	13,14,16,17,18	1,60	2,15
500 313 62	90 x 50 x 116 x 3,0	1,2,3,5,6,9	23,24,25,26,31	2,61	2,57
641 598 30	90 x 48 x 76 x 3,0	1,2,3,6	16,17,20,21	1,95	4,11
641 912 30	120 x 90 x 40 x 3,0	1,2,3,4,5	10,11,12,13,14,15	2,56	2,93
641 690 25	90 x 60 x 60 x 2,5	1,2	6,7,8,9	1,76	1,42
641 590 25	90 x 50 x 50 x 2,5	1,3,5,6	13,14,16,17,18	1,58	1,49
641 490 25	90 x 40 x 40 x 2,5	1,2	8,9,11,12	1,83	1,67
641 490 30	90 x 40 x 40 x 3,0	1,2	8,9,11,12	1,83	2,41
651 554 25	50 x 50 x 40 x 2,5	-	-	-	-
651 070 25	70 x 70 x 55 x 2,5	1,2,3	12,13,14,15,16,20,21,22	3,05	1,56
651 994 25	90 x 90 x 40 x 2,5	1,2	11,12,14,15,19,20	2,28	1,23
651 090 25	90 x 90 x 65 x 2,5	1,2,4,5	10,11,12,13,15,16,17,19,20	4,84	2,34
651 105 30	105 x 105 x 90 x 3,0	1,2,4,5,6,8,10	18,19,20,21,27,28,29,33,34	4,85	4,50
641 416 40	160 x 50 x 40 x 3,0	1,2,3,4,5,6,7	13,14	1,40	1,44
631 810 20	80 x 80 x 100 x 2,0	1,2,3,4	19,20,21,22,23,24,25,26,27,28,29,30,31,32,33,34,35,36	5,10	4,00
631 860 20	80 x 80 x 60 x 2,0	1,2,3	11,12,13,14,15,16,17,18,19,20	3,82	2,25
631 880 20	80 x 80 x 80 x 2,0	1,2,3,4	15,16,17,18,19,20,21,22,23,24,25,26,27,28	5,10	3,00
631 140 20	100 x 100 x 40 x 2,0	1,2,3,4	11,12,13,14,15,16,17,18,19,20	2,58	1,25
631 160 20	100 x 100 x 60 x 2,5	1,2,3,4,5	14,15,16,17,18,19,20,21,22,23,24,25	2,61	3,55
631 180 20	100 x 100 x 80 x 2,0	1,2,3,4,5,6,7	18,19,20,21,22,23,24,25,26,27,28,29,30,31,32,33,34,35	5,26	3,00
631 110 20	100 x 100 x 100 x 2,0	1,2,3,4,5,6,7,8,9	24,25,26,27,28,29,30,31,32,33,34,35,36,37,38,39,40,41,42,43,44,45	5,26	4,00
RHV 60	80 x 80 x 60 x 1,5	1,3	8,9,10,12	1,76	4,15
RHV 80	120 x 120 x 75 x 1,5	1,2,4,6,7	12,13,15,18,19,21,23,24	2,12	6,95
633 710 66	100 x 75 x 60 x 6,0	1	2	-	7,62
		$k_t = 0,78$			

Table B.2: Force F_1 Column, 1 angle bracket / connection

Bracket number	Bracket type	Nail number n_v	Nail number n_h	$F_{1,Rk}$ [kN] (column)	
				Timber	Steel
633 753 20	70 x 50 x 30 x 2,0	1,2	7,8	0,83	0,14
633 853 25	80 x 50 x 30 x 2,5	1,2	9,10	1,06	0,34
631 860 25	80 x 80 x 60 x 2,5	1,2,3	11,12,13,14,15,16,17,18,19,20	1,85	1,41
631 880 25	80 x 80 x 80 x 2,5	1,2,3,4	15,16,17,18,19,20,21,22,23,24,25,26,27,28	2,47	1,88
631 810 25	80 x 80 x 100 x 2,5	1,2,3,4	19,20,21,22,23,24,25,26,27,28,29,30,31,32,33,34,35,36	2,55	3,13
631 160 25	100 x 100 x 60 x 2,5	1,2,3,4,5	14,15,16,17,18,19,20,21,22,23,24,25	1,32	1,95
631 180 25	100 x 100 x 80 x 2,5	1,2,3,4,5,6,7	18,19,20,21,22,23,24,25,26,27,28,29,30,31,32,33,34,35	2,63	2,34
631 110 25	100 x 100 x 100 x 2,5	1,2,3,4,5,6,7,8,9	24,25,26,27,28,29,30,31,32,33,34,35,36,37,38,39,40,41,42,43,44,45	2,63	3,69
641 994 30	90 x 90 x 40 x 3,0	1,2	11,12,14,15,19,20	1,15	0,91
641 595 30	90 x 50 x 50 x 3,0	1,3,5,6	13,14,16,17,18	0,80	1,07
500 313 62	90 x 50 x 116 x 3,0	1,2,3,5,6,9	23,24,25,26,31	1,31	1,28
641 598 30	90 x 48 x 76 x 3,0	1,2,3,6	16,17,20,21	0,97	2,06
641 912 30	120 x 90 x 40 x 3,0	1,2,3,4,5	10,11,12,13,14,15	1,28	1,47
641 690 25	90 x 60 x 60 x 2,5	1,2	6,7,8,9	0,88	0,71
641 590 25	90 x 50 x 50 x 2,5	1,3,5,6	13,14,16,17,18	0,79	0,74
641 490 25	90 x 40 x 40 x 2,5	1,2	8,9,11,12	0,91	0,84
641 490 30	90 x 40 x 40 x 3,0	1,2	8,9,11,12	0,91	1,21
651 070 25	70 x 70 x 55 x 2,5	1,2,3	12,13,14,15,16,20,21,22	1,53	0,78
651 994 25	90 x 90 x 40 x 2,5	1,2	11,12,14,15,19,20	1,14	0,62
651 090 25	90 x 90 x 65 x 2,5	1,2,4,5	10,11,12,13,15,16,17,19,20	2,42	1,17
651 105 30	105 x 105 x 90 x 3,0	1,2,4,5,6,8,10	18,19,20,21,27,28,29,33,34	2,43	2,25
641 416 40	160 x 50 x 40 x 3,0	1,2,3,4,5,6,7	13,14	0,70	0,72
631 810 20	80 x 80 x 100 x 2,0	1,2,3,4	19,20,21,22,23,24,25,26,27,28,29,30,31,32,33,34,35,36	2,55	2,00
631 860 20	80 x 80 x 60 x 2,0	1,2,3	11,12,13,14,15,16,17,18,19,20	1,91	1,13
631 880 20	80 x 80 x 80 x 2,0	1,2,3,4	15,16,17,18,19,20,21,22,23,24,25,26,27,28	2,55	1,50
631 140 20	100 x 100 x 40 x 2,0	1,2,3,4	11,12,13,14,15,16,17,18,19,20	1,29	0,63
631 160 20	100 x 100 x 60 x 2,5	1,2,3,4,5	14,15,16,17,18,19,20,21,22,23,24,25	1,30	1,78
631 180 20	100 x 100 x 80 x 2,0	1,2,3,4,5,6,7	18,19,20,21,22,23,24,25,26,27,28,29,30,31,32,33,34,35	2,63	1,50
631 110 20	100 x 100 x 100 x 2,0	1,2,3,4,5,6,7,8,9	24,25,26,27,28,29,30,31,32,33,34,35,36,37,38,39,40,41,42,43,44,45	2,63	2,00
RHV 60	80 x 80 x 60 x 1,5	1,3	8,9,10,12	0,88	2,07
RHV 80	120 x 120 x 75 x 1,5	1,2,4,6,7	12,13,15,18,19,21,23,24	1,06	3,48
633 710 66	100 x 75 x 60 x 6,0	1	2	-	3,81
		$k_t = 1,55$			

Table B.3: Force F_1 Purlin, 2 angle brackets / connection

Bracket number	Bracket type	Nail number n_v	Nail number n_h	$F_{1,Rk}$ [kN] (purlin)	
				Timber	Steel
633 553 20	50 x 50 x 30 x 2,0	1,2	5,6	1,66	0,28
633 753 20	70 x 50 x 30 x 2,0	1,2,3,4,5,6	7,8	1,66	0,28
633 853 25	80 x 50 x 30 x 2,5	1,2,3,4,5,6	9,10	2,11	0,68
631 460 25	40 x 40 x 60 x 2,5	1,2,3	6,7,8,9,10	3,15	3,52
631 480 25	40 x 40 x 80 x 2,5	1,2,3	8,9,10,11,12,13,14	2,94	4,06
631 640 25	60 x 60 x 40 x 2,5	1,2,3	6,7,8,9	1,11	2,04
631 650 25	60 x 60 x 50 x 2,5	1,2,3,4,5	8,9,10,11,12,13,14,15	3,45	2,19
631 660 25	60 x 60 x 60 x 2,5	1,2,3,4,5,6	10,11,12,13,14,15,16,17,18	3,34	2,63
631 680 25	60 x 60 x 80 x 2,5	1,2,3,4,5,6,7	12,13,14,15,16,17,18,19,20,21	3,34	3,80
631 610 25	60 x 60 x 100 x 2,5	1,2,3,4,5,6,7,8,9	15,16,17,18,19,20,21,22,23,24,25,26,27	4,76	5,68
631 480 25	80 x 80 x 40 x 2,5	1,2,3,4	7,8,9,10,11,12	1,27	2,73
631 860 25	80 x 80 x 60 x 2,5	1,2,3,4,5,6,7,8	11,12,13,14,15,16,17,18,19,20	3,70	2,81
631 880 25	80 x 80 x 80 x 2,5	1,2,3,4,5,6,7,8,9,10,11	15,16,17,18,19,20,21,22,23,24,25,26,27,28	4,93	3,75
631 810 25	80 x 80 x 100 x 2,5	1,2,3,4,5,6,7,8,9,10,11,12,13	19,20,21,22,23,24,25,26,27,28,29,30,31,32,33,34,35,36	5,10	6,25
631 160 25	100 x 100 x 60 x 2,5	1,2,3,4,5,6,7,8,9,10	14,15,16,17,18,19,20,21,22,23,24,25	2,63	3,91
631 180 25	100 x 100 x 80 x 2,5	1,2,3,4,5,6,7,8,9,10,11,12,13,14	18,19,20,21,22,23,24,25,26,27,28,29,30,31,32,33,34,35	5,26	4,69
631 110 25	100 x 100 x 100 x 2,5	1,2,3,4,5,6,7,8,9,10,11,12,13,14,15,16,17,18	24,25,26,27,28,29,30,31,32,33,34,35,36,37,38,39,40,41,42,43,44,45	5,26	7,38
631 554 20	50 x 50 x 40 x 2,0	1,2,3	7,8,9,10,11,12	1,14	1,75
634 100 20	40 x 40 x 100 x 2,0	1,2,3,4,5	10,11,12,13,14,15,16,17,18	4,67	2,94
634 150 20	40 x 40 x 150 x 2,0	1,2,3	11,12,13,14,15,16,17,18,19,20	2,86	5,19
634 200 20	40 x 40 x 200 x 2,0	1,2,3,4,5	16,17,18,19,20,21,22,23,24,25,26,27,28,29,30	4,77	6,73
641 035 25	50 x 50 x 35 x 2,5	1,2	6,7,9,10	2,12	1,56
641 040 30	50 x 50 x 40 x 3,0	1,2	6,7,9,10	1,80	1,93
641 664 30	60 x 60 x 45 x 3,0	1,2,3,5	8,9,13,14	2,00	2,25
641 994 30	90 x 90 x 40 x 3,0	1,2,4,5,6,7	11,12,14,15,19,20	2,30	1,82
641 595 30	90 x 50 x 50 x 3,0	1,3,5,6,7,8,9	13,14,16,17,18	1,60	2,15
500 313 62	90 x 50 x 116 x 3,0	1,2,3,5,6,9,11,12,13,14,17,18,20	23,24,25,26,31	2,61	2,57
641 598 30	90 x 48 x 76 x 3,0	1,2,3,6,7,8,9,10,11,12	16,17,20,21	1,95	4,11
641 912 30	120 x 90 x 40 x 3,0	1,2,3,4,5,6,7,8	10,11,12,13,14,15	2,56	2,93
641 690 25	90 x 60 x 60 x 2,5	1,2,3	6,7,8,9	1,76	1,42
641 590 25	90 x 50 x 50 x 2,5	1,3,5,6,7,8,9	13,14,16,17,18	1,58	1,49
641 490 25	90 x 40 x 40 x 2,5	1,2,3,4	8,9,11,12	1,83	1,67
641 490 30	90 x 40 x 40 x 3,0	1,2,3,4	8,9,11,12	1,83	2,41

651 554 25	50 x 50 x 40 x 2,5	1,2	6,7,9,10	1,80	1,34
651 070 25	70 x 70 x 55 x 2,5	1,2,3,4,6,7,8,	12,13,14,15,16,20,21,22	3,05	1,56
651 994 25	90 x 90 x 40 x 2,5	1,2,4,5,6,7	11,12,14,15,19,20	2,28	1,23
651 090 25	90 x 90 x 65 x 2,5	1,2,4,5,6,7	10,11,12,13,15,16,17,19,20	4,84	2,34
651 105 30	105 x 105 x 90 x 3,0	1,2,4,5,6,8,10,11,12,13,14,15	18,19,20,21,27,28,29,33,34	4,85	4,50
641 416 40	160 x 50 x 40 x 3,0	1,2,3,4,5,6,7,8,9,10	13,14	1,40	1,44
631 460 20	40 x 40 x 60 x 2,0	1,2,3	6,7,8,9,10	3,15	2,25
631 480 20	40 x 40 x 80 x 2,0	1,2,3	8,9,10,11,12,13,14	2,80	2,55
631 610 20	60 x 60 x 100 x 2,0	1,2,3,4,5,6,7,8,9	15,16,17,18,19,20,21,22,23,24,25,26,27	4,81	4,00
631 640 20	60 x 60 x 40 x 2,0	1,2,3	6,7,8,9	1,11	1,31
631 650 20	60 x 60 x 50 x 2,0	1,2,3,4	7,8,9,10,11,12	2,41	2,00
631 660 20	60 x 60 x 60 x 2,0	1,2,3,4,5,6	10,12,13,14,15,16,18	3,61	2,25
631 680 20	60 x 60 x 80 x 2,0	1,2,3,4,5,6,7	12,13,14,15,16,17,18,19,20,21	3,34	3,80
631 810 20	80 x 80 x 100 x 2,0	1,2,3,4,5,6,7,8,9,10,11,12,13	19,20,21,22,23,24,25,26,27,28,29,30,31,32,33,34,35,36	5,10	4,00
631 480 20	80 x 80 x 40 x 2,0	1,2,3,4	7,8,9,10,11,12	1,27	1,75
631 860 20	80 x 80 x 60 x 2,0	1,2,3,4,5,6,7,8	11,12,13,14,15,16,17,18,19,20	3,82	2,25
631 880 20	80 x 80 x 80 x 2,0	1,2,3,4,5,6,7,8,9,10,11	15,16,17,18,19,20,21,22,23,24,25,26,27,28	5,10	3,00
631 140 20	100 x 100 x 40 x 2,0	1,2,3,4,5,6,7,8	11,12,13,14,15,16,17,18,19,20	2,58	1,25
631 160 20	100 x 100 x 60 x 2,5	1,2,3,4,5,6,7,8,9,10	14,15,16,17,18,19,20,21,22,23,24,25	2,61	3,55
631 180 20	100 x 100 x 80 x 2,0	1,2,3,4,5,6,7,8,9,10,11,12,13,14	18,19,20,21,22,23,24,25,26,27,28,29,30,31,32,33,34,35	5,26	3,00
631 110 20	100 x 100 x 100 x 2,0	1,2,3,4,5,6,7,8,9,10,11,12,13,14,15,16,17,18	24,25,26,27,28,29,30,31,32,33,34,35,36,37,38,39,40,41,42,43,44,45	5,26	4,00
RHV 60	80 x 80 x 60 x 1,5	1,3,4,5	8,9,10,12	1,76	4,15
RHV 80	120 x 120 x 75 x 1,5	1,2,4,6,7,10	12,13,15,18,19,21,23,24	2,12	6,95
633 710 66	100 x 75 x 60 x 6,0	1	2	-	7,62
		k _t = 0,78			

Table B.4: Force F_1 Purlin, 1 angle bracket / connection

Bracket number	Bracket type	Nail number n_v	Nail number n_h	$F_{1,Rk}$ [kN] (purlin)	
				Timber	Steel
633 553 20	50 x 50 x 30 x 2,0	1,2	5,6	0,83	0,14
633 753 20	70 x 50 x 30 x 2,0	1,2,3,4,5,6	7,8	0,83	0,14
633 853 25	80 x 50 x 30 x 2,5	1,2,3,4,5,6	9,10	1,06	0,34
631 460 25	40 x 40 x 60 x 2,5	1,2,3	6,7,8,9,10	1,58	1,76
631 480 25	40 x 40 x 80 x 2,5	1,2,3	8,9,10,11,12,13,14	1,47	2,03
631 640 25	60 x 60 x 40 x 2,5	1,2,3	6,7,8,9	0,56	1,02
631 650 25	60 x 60 x 50 x 2,5	1,2,3,4,5	8,9,10,11,12,13,14,15	1,73	1,09
631 660 25	60 x 60 x 60 x 2,5	1,2,3,4,5,6	10,11,12,13,14,15,16,17,18	1,67	1,31
631 680 25	60 x 60 x 80 x 2,5	1,2,3,4,5,6,7	12,13,14,15,16,17,18,19,20,21	1,67	1,90
631 610 25	60 x 60 x 100 x 2,5	1,2,3,4,5,6,7,8,9	15,16,17,18,19,20,21,22,23,24,25,26,27	2,38	2,84
631 480 25	80 x 80 x 40 x 2,5	1,2,3,4	7,8,9,10,11,12	0,64	1,37
631 860 25	80 x 80 x 60 x 2,5	1,2,3,4,5,6,7,8	11,12,13,14,15,16,17,18,19,20	1,85	1,41
631 880 25	80 x 80 x 80 x 2,5	1,2,3,4,5,6,7,8,9,10,11	15,16,17,18,19,20,21,22,23,24,25,26,27,28	2,47	1,88
631 810 25	80 x 80 x 100 x 2,5	1,2,3,4,5,6,7,8,9,10,11,12,13	19,20,21,22,23,24,25,26,27,28,29,30,31,32,33,34,35,36	2,55	3,13
631 160 25	100 x 100 x 60 x 2,5	1,2,3,4,5,6,7,8,9,10	14,15,16,17,18,19,20,21,22,23,24,25	1,32	1,95
631 180 25	100 x 100 x 80 x 2,5	1,2,3,4,5,6,7,8,9,10,11,12,13,14	18,19,20,21,22,23,24,25,26,27,28,29,30,31,32,33,34,35	2,63	2,34
631 110 25	100 x 100 x 100 x 2,5	1,2,3,4,5,6,7,8,9,10,11,12,13,14,15,16,17,18	24,25,26,27,28,29,30,31,32,33,34,35,36,37,38,39,40,41,42,43,44,45	2,63	3,69
631 554 20	50 x 50 x 40 x 2,0	1,2,3	7,8,9,10,11,12	0,57	0,88
634 100 20	40 x 40 x 100 x 2,0	1,2,3,4,5	10,11,12,13,14,15,16,17,18	2,33	1,47
634 150 20	40 x 40 x 150 x 2,0	1,2,3	11,12,13,14,15,16,17,18,19,20	1,43	2,60
634 200 20	40 x 40 x 200 x 2,0	1,2,3,4,5	16,17,18,19,20,21,22,23,24,25,26,27,28,29,30	2,38	3,37
641 035 25	50 x 50 x 35 x 2,5	1,2	6,7,9,10	1,06	0,78
641 040 30	50 x 50 x 40 x 3,0	1,2	6,7,9,10	0,90	0,96
641 664 30	60 x 60 x 45 x 3,0	1,2,3,5	8,9,13,14	1,00	1,13
641 994 30	90 x 90 x 40 x 3,0	1,2,4,5,6,7	11,12,14,15,19,20	1,15	0,91
641 595 30	90 x 50 x 50 x 3,0	1,3,5,6,7,8,9	13,14,16,17,18	0,80	1,07
500 313 62	90 x 50 x 116 x 3,0	1,2,3,5,6,9,11,12,13,14,17,18,20	23,24,25,26,31	1,31	1,28
641 598 30	90 x 48 x 76 x 3,0	1,2,3,6,7,8,9,10,11,12	16,17,20,21	0,97	2,06
641 912 30	120 x 90 x 40 x 3,0	1,2,3,4,5,6,7,8	10,11,12,13,14,15	1,28	1,47
641 690 25	90 x 60 x 60 x 2,5	1,2,3	6,7,8,9	0,88	0,71
641 590 25	90 x 50 x 50 x 2,5	1,3,5,6,7,8,9	13,14,16,17,18	0,79	0,74
641 490 25	90 x 40 x 40 x 2,5	1,2,3,4	8,9,11,12	0,91	0,84
641 490 30	90 x 40 x 40 x 3,0	1,2,3,4	8,9,11,12	0,91	1,21

651 554 25	50 x 50 x 40 x 2,5	1,2	6,7,9,10	0,90	0,67
651 070 25	70 x 70 x 55 x 2,5	1,2,3,4,6,7,8,	12,13,14,15,16,20,21,22	1,53	0,78
651 994 25	90 x 90 x 40 x 2,5	1,2,4,5,6,7	11,12,14,15,19,20	1,14	0,62
651 090 25	90 x 90 x 65 x 2,5	1,2,4,5,6,7	10,11,12,13,15,16,17,19,20	2,42	1,17
651 105 30	105 x 105 x 90 x 3,0	1,2,4,5,6,8,10,11,12, 13,14,15	18,19,20,21,27,28,29,33,34	2,43	2,25
641 416 40	160 x 50 x 40 x 3,0	1,2,3,4,5,6,7,8,9,10	13,14	0,70	0,72
631 460 20	40 x 40 x 60 x 2,0	1,2,3	6,7,8,9,10	1,58	1,13
631 480 20	40 x 40 x 80 x 2,0	1,2,3	8,9,10,11,12,13,14	1,40	1,27
631 610 20	60 x 60 x 100 x 2,0	1,2,3,4,5,6,7,8,9	15,16,17,18,19,20,21,22,23,2 4,25,26,27	2,41	2,00
631 640 20	60 x 60 x 40 x 2,0	1,2,3	6,7,8,9	0,56	0,65
631 650 20	60 x 60 x 50 x 2,0	1,2,3,4	7,8,9,10,11,12	1,20	1,00
631 660 20	60 x 60 x 60 x 2,0	1,2,3,4,5,6	10,12,13,14,15,16,18	1,80	1,13
631 680 20	60 x 60 x 80 x 2,0	1,2,3,4,5,6,7	12,13,14,15,16,17,18,19,20,2 1	1,67	1,90
631 810 20	80 x 80 x 100 x 2,0	1,2,3,4,5,6,7,8,9,10,1 1,12,13	19,20,21,22,23,24,25,26,27,2 8,29,30,31,32,33,34,35,36	2,55	2,00
631 480 20	80 x 80 x 40 x 2,0	1,2,3,4	7,8,9,10,11,12	0,64	0,88
631 860 20	80 x 80 x 60 x 2,0	1,2,3,4,5,6,7,8	11,12,13,14,15,16,17,18,19,2 0	1,91	1,13
631 880 20	80 x 80 x 80 x 2,0	1,2,3,4,5,6,7,8,9,10,1 1	15,16,17,18,19,20,21,22,23,2 4,25,26,27,28	2,55	1,50
631 140 20	100 x 100 x 40 x 2,0	1,2,3,4,5,6,7,8	11,12,13,14,15,16,17,18,19,2 0	1,29	0,63
631 160 20	100 x 100 x 60 x 2,5	1,2,3,4,5,6,7,8,9,10	14,15,16,17,18,19,20,21,22,2 3,24,25	1,30	1,78
631 180 20	100 x 100 x 80 x 2,0	1,2,3,4,5,6,7,8,9,10,1 1,12,13,14	18,19,20,21,22,23,24,25,26,2 7,28,29,30,31,32,33,34,35	2,63	1,50
631 110 20	100 x 100 x 100 x 2,0	1,2,3,4,5,6,7,8,9,10,1 1,12,13,14,15,16,17, 18	24,25,26,27,28,29,30,31,32,3 3,34,35,36,37,38,39,40,41,42, 43,44,45	2,63	2,00
RHV 60	80 x 80 x 60 x 1,5	1,3,4,5	8,9,10,12	0,88	2,07
RHV 80	120 x 120 x 75 x 1,5	1,2,4,6,7,10	12,13,15,18,19,21,23,24	1,06	3,48
633 710 66	100 x 75 x 60 x 6,0	1	2	-	3,81
		k _t = 1,55			

Table B.5: Forces $F_{2,3}$, 2 angle brackets / connection

Bracket number	Bracket type	Nail number n_v	Nail number n_h	$F_{2,3,Rk}$ [kN]
				Timber
633 553 20	50 x 50 x 30 x 2,0	1,2	5,6	2,38
633 753 20	70 x 50 x 30 x 2,0	1,2,3,4,5,6	7,8	2,83
633 853 25	80 x 50 x 30 x 2,5	1,2,3,4,5,6	9,10	2,26
631 460 25	40 x 40 x 60 x 2,5	1,2,3	6,7,8,9,10	5,31
631 480 25	40 x 40 x 80 x 2,5	1,2,3	8,9,10,11,12,13,14	6,35
631 640 25	60 x 60 x 40 x 2,5	1,2,3	6,7,8,9	2,18
631 650 25	60 x 60 x 50 x 2,5	1,2,3,4,5	8,9,10,11,12,13,14,15	6,27
631 660 25	60 x 60 x 60 x 2,5	1,2,3,4,5,6	10,11,12,13,14,15,16,17,18	7,23
631 680 25	60 x 60 x 80 x 2,5	1,2,3,4,5,6,7	12,13,14,15,16,17,18,19,20,21	9,22
631 610 25	60 x 60 x 100 x 2,5	1,2,3,4,5,6,7,8,9	15,16,17,18,19,20,21,22,23,24,25,26,27	13,8
631 480 25	80 x 80 x 40 x 2,5	1,2,3,4	7,8,9,10,11,12	3,15
631 860 25	80 x 80 x 60 x 2,5	1,2,3,4,5,6,7,8	11,12,13,14,15,16,17,18,19,20	8,38
631 880 25	80 x 80 x 80 x 2,5	1,2,3,4,5,6,7,8,9,10,11	15,16,17,18,19,20,21,22,23,24,25,26,27,28	12,9
631 810 25	80 x 80 x 100 x 2,5	1,2,3,4,5,6,7,8,9,10,11,12,13	19,20,21,22,23,24,25,26,27,28,29,30,31,32,33,34,35,36	17,7
631 160 25	100 x 100 x 60 x 2,5	1,2,3,4,5,6,7,8,9,10	14,15,16,17,18,19,20,21,22,23,24,25	8,85
631 180 25	100 x 100 x 80 x 2,5	1,2,3,4,5,6,7,8,9,10,11,12,13,14	18,19,20,21,22,23,24,25,26,27,28,29,30,31,32,33,34,35	15,5
631 110 25	100 x 100 x 100 x 2,5	1,2,3,4,5,6,7,8,9,10,11,12,13,14,15,16,17,18	24,25,26,27,28,29,30,31,32,33,34,35,36,37,38,39,40,41,42,43,44,45	20,2
631 554 20	50 x 50 x 40 x 2,0	1,2,3	7,8,9,10,11,12	3,35
634 100 20	40 x 40 x 100 x 2,0	1,2,3,4,5	10,11,12,13,14,15,16,17,18	12,1
634 150 20	40 x 40 x 150 x 2,0	1,2,3	11,12,13,14,15,16,17,18,19,20	9,69
634 200 20	40 x 40 x 200 x 2,0	1,2,3,4,5	16,17,18,19,20,21,22,23,24,25,26,27,28,29,30	16,1
641 035 25	50 x 50 x 35 x 2,5	1,2	6,7,9,10	2,59
641 040 30	50 x 50 x 40 x 3,0	1,2	6,7,9,10	2,53
641 664 30	60 x 60 x 45 x 3,0	1,2,3,5	8,9,13,14	4,23
641 994 30	90 x 90 x 40 x 3,0	1,2,4,5,6,7	11,12,14,15,19,20	4,70
641 595 30	90 x 50 x 50 x 3,0	1,3,5,6,7,8,9	13,14,16,17,18	5,46
500 313 62	90 x 50 x 116 x 3,0	1,2,3,5,6,9,11,12,13,14,17,18,20	23,24,25,26,31	9,16
641 598 30	90 x 48 x 76 x 3,0	1,2,3,6,7,8,9,10,11,12	16,17,20,21	7,78
641 912 30	120 x 90 x 40 x 3,0	1,2,3,4,5,6,7,8	10,11,12,13,14,15	5,68
641 690 25	90 x 60 x 60 x 2,5	1,2,3	6,7,8,9	2,99
641 590 25	90 x 50 x 50 x 2,5	1,3,5,6,7,8,9	13,14,16,17,18	5,50
641 490 25	90 x 40 x 40 x 2,5	1,2,3,4	8,9,11,12	3,19
641 490 30	90 x 40 x 40 x 3,0	1,2,3,4	8,9,11,12	3,17

651 070 25	70 x 70 x 55 x 2,5	1,2,3,4,6,7,8,	12,13,14,15,16,20,21,22	7,18
651 090 25	90 x 90 x 65 x 2,5	1,2,4,5,6,7	10,11,12,13,15,16,17,19,20	7,10
651 105 30	105 x 105 x 90 x 3,0	1,2,4,5,6,8,10,11,12,13, 14,15	18,19,20,21,27,28,29,33,34	11,5
641 416 40	160 x 50 x 40 x 3,0	1,2,3,4,5,6,7,8,9,10	13,14	2,8,9
631 460 20	40 x 40 x 60 x 2,0	1,2,3	6,7,8,9,10	5,34
631 480 20	40 x 40 x 80 x 2,0	1,2,3	8,9,10,11,12,13,14	6,67
631 610 20	60 x 60 x 100 x 2,0	1,2,3,4,5,6,7,8,9	15,16,17,18,19,20,21,22,23,24,25, 26,27	14,3
631 640 20	60 x 60 x 40 x 2,0	1,2,3	6,7,8,9	2,20
631 650 20	60 x 60 x 50 x 2,0	1,2,3,4	7,8,9,10,11,12	4,36
631 660 20	60 x 60 x 60 x 2,0	1,2,3,4,5,6	10,12,13,14,15,16,18	6,28
631 680 20	60 x 60 x 80 x 2,0	1,2,3,4,5,6,7	12,13,14,15,16,17,18,19,20,21	9,22
631 810 20	80 x 80 x 100 x 2,0	1,2,3,4,5,6,7,8,9,10,11, 12,13	19,20,21,22,23,24,25,26,27,28,29, 30,31,32,33,34,35,36	17,6
631 480 20	80 x 80 x 40 x 2,0	1,2,3,4	7,8,9,10,11,12	3,17
631 860 20	80 x 80 x 60 x 2,0	1,2,3,4,5,6,7,8	11,12,13,14,15,16,17,18,19,20	8,77
631 880 20	80 x 80 x 80 x 2,0	1,2,3,4,5,6,7,8,9,10,11	15,16,17,18,19,20,21,22,23,24,25, 26,27,28	13,7
631 140 20	100 x 100 x 40 x 2,0	1,2,3,4,5,6,7,8	11,12,13,14,15,16,17,18,19,20	7,06
631 160 20	100 x 100 x 60 x 2,5	1,2,3,4,5,6,7,8,9,10	14,15,16,17,18,19,20,21,22,23,24, 25	8,61
631 180 20	100 x 100 x 80 x 2,0	1,2,3,4,5,6,7,8,9,10,11, 12,13,14	18,19,20,21,22,23,24,25,26,27,28, 29,30,31,32,33,34,35	15,6
631 110 20	100 x 100 x 100 x 2,0	1,2,3,4,5,6,7,8,9,10,11, 12,13,14,15,16,17,18	24,25,26,27,28,29,30,31,32,33,34, 35,36,37,38,39,40,41,42,43,44,45	20,9
RHV 60	80 x 80 x 60 x 1,5	1,3,4,5	8,9,10,12	3,82
RHV 80	120 x 120 x 75 x 1,5	1,2,4,6,7,10	12,13,15,18,19,21,23,24	5,76

Table B.6: Forces $F_{2,3}$, 1 angle bracket / connection

Bracket number	Bracket type	Nail number n_v	Nail number n_h	$F_{2,3,Rk}$ [kN]
				Timber
633 553 20	50 x 50 x 30 x 2,0	1,2	5,6	1,19
633 753 20	70 x 50 x 30 x 2,0	1,2,3,4,5,6	7,8	1,42
633 853 25	80 x 50 x 30 x 2,5	1,2,3,4,5,6	9,10	1,13
631 460 25	40 x 40 x 60 x 2,5	1,2,3	6,7,8,9,10	2,65
631 480 25	40 x 40 x 80 x 2,5	1,2,3	8,9,10,11,12,13,14	3,17
631 640 25	60 x 60 x 40 x 2,5	1,2,3	6,7,8,9	1,09
631 650 25	60 x 60 x 50 x 2,5	1,2,3,4,5	8,9,10,11,12,13,14,15	3,13
631 660 25	60 x 60 x 60 x 2,5	1,2,3,4,5,6	10,11,12,13,14,15,16,17,18	3,62
631 680 25	60 x 60 x 80 x 2,5	1,2,3,4,5,6,7	12,13,14,15,16,17,18,19,20,21	4,61
631 610 25	60 x 60 x 100 x 2,5	1,2,3,4,5,6,7,8,9	15,16,17,18,19,20,21,22,23,24,25,26,27	6,89
631 480 25	80 x 80 x 40 x 2,5	1,2,3,4	7,8,9,10,11,12	1,58
631 860 25	80 x 80 x 60 x 2,5	1,2,3,4,5,6,7,8	11,12,13,14,15,16,17,18,19,20	4,19
631 880 25	80 x 80 x 80 x 2,5	1,2,3,4,5,6,7,8,9,10,11	15,16,17,18,19,20,21,22,23,24,25,26,27,28	6,47
631 810 25	80 x 80 x 100 x 2,5	1,2,3,4,5,6,7,8,9,10,11,12,13	19,20,21,22,23,24,25,26,27,28,29,30,31,32,33,34,35,36	8,84
631 160 25	100 x 100 x 60 x 2,5	1,2,3,4,5,6,7,8,9,10	14,15,16,17,18,19,20,21,22,23,24,25	4,42
631 180 25	100 x 100 x 80 x 2,5	1,2,3,4,5,6,7,8,9,10,11,12,13,14	18,19,20,21,22,23,24,25,26,27,28,29,30,31,32,33,34,35	7,76
631 110 25	100 x 100 x 100 x 2,5	1,2,3,4,5,6,7,8,9,10,11,12,13,14,15,16,17,18	24,25,26,27,28,29,30,31,32,33,34,35,36,37,38,39,40,41,42,43,44,45	10,1
631 554 20	50 x 50 x 40 x 2,0	1,2,3	7,8,9,10,11,12	1,68
634 100 20	40 x 40 x 100 x 2,0	1,2,3,4,5	10,11,12,13,14,15,16,17,18	6,08
634 150 20	40 x 40 x 150 x 2,0	1,2,3	11,12,13,14,15,16,17,18,19,20	4,85
634 200 20	40 x 40 x 200 x 2,0	1,2,3,4,5	16,17,18,19,20,21,22,23,24,25,26,27,28,29,30	8,08
641 035 25	50 x 50 x 35 x 2,5	1,2	6,7,9,10	1,29
641 040 30	50 x 50 x 40 x 3,0	1,2	6,7,9,10	1,27
641 664 30	60 x 60 x 45 x 3,0	1,2,3,5	8,9,13,14	2,11
641 994 30	90 x 90 x 40 x 3,0	1,2,4,5,6,7	11,12,14,15,19,20	2,35
641 595 30	90 x 50 x 50 x 3,0	1,3,5,6,7,8,9	13,14,16,17,18	2,73
500 313 62	90 x 50 x 116 x 3,0	1,2,3,5,6,9,11,12,13,14,17,18,20	23,24,25,26,31	4,58
641 598 30	90 x 48 x 76 x 3,0	1,2,3,6,7,8,9,10,11,12	16,17,20,21	3,89
641 912 30	120 x 90 x 40 x 3,0	1,2,3,4,5,6,7,8	10,11,12,13,14,15	2,84
641 690 25	90 x 60 x 60 x 2,5	1,2,3	6,7,8,9	1,50
641 590 25	90 x 50 x 50 x 2,5	1,3,5,6,7,8,9	13,14,16,17,18	2,75
641 490 25	90 x 40 x 40 x 2,5	1,2,3,4	8,9,11,12	1,59

641 490 30	90 x 40 x 40 x 3,0	1,2,3,4	8,9,11,12	1,58
651 070 25	70 x 70 x 55 x 2,5	1,2,3,4,6,7,8,	12,13,14,15,16,20,21,22	3,59
651 090 25	90 x 90 x 65 x 2,5	1,2,4,5,6,7	10,11,12,13,15,16,17,19,20	3,55
651 105 30	105 x 105 x 90 x 3,0	1,2,4,5,6,8,10,11,12,13,14,15	18,19,20,21,27,28,29,33,34	5,74
641 416 40	160 x 50 x 40 x 3,0	1,2,3,4,5,6,7,8,9,10	13,14	1,45
631 460 20	40 x 40 x 60 x 2,0	1,2,3	6,7,8,9,10	2,67
631 480 20	40 x 40 x 80 x 2,0	1,2,3	8,9,10,11,12,13,14	3,34
631 610 20	60 x 60 x 100 x 2,0	1,2,3,4,5,6,7,8,9	15,16,17,18,19,20,21,22,23,24,25,26,27	7,16
631 640 20	60 x 60 x 40 x 2,0	1,2,3	6,7,8,9	1,10
631 650 20	60 x 60 x 50 x 2,0	1,2,3,4	7,8,9,10,11,12	2,18
631 660 20	60 x 60 x 60 x 2,0	1,2,3,4,5,6	10,12,13,14,15,16,18	3,14
631 680 20	60 x 60 x 80 x 2,0	1,2,3,4,5,6,7	12,13,14,15,16,17,18,19,20,21	4,61
631 810 20	80 x 80 x 100 x 2,0	1,2,3,4,5,6,7,8,9,10,11,12,13	19,20,21,22,23,24,25,26,27,28,29,30,31,32,33,34,35,36	8,81
631 480 20	80 x 80 x 40 x 2,0	1,2,3,4	7,8,9,10,11,12	1,59
631 860 20	80 x 80 x 60 x 2,0	1,2,3,4,5,6,7,8	11,12,13,14,15,16,17,18,19,20	4,38
631 880 20	80 x 80 x 80 x 2,0	1,2,3,4,5,6,7,8,9,10,11	15,16,17,18,19,20,21,22,23,24,25,26,27,28	6,85
631 140 20	100 x 100 x 40 x 2,0	1,2,3,4,5,6,7,8	11,12,13,14,15,16,17,18,19,20	3,53
631 160 20	100 x 100 x 60 x 2,5	1,2,3,4,5,6,7,8,9,10	14,15,16,17,18,19,20,21,22,23,24,25	4,30
631 180 20	100 x 100 x 80 x 2,0	1,2,3,4,5,6,7,8,9,10,11,12,13,14	18,19,20,21,22,23,24,25,26,27,28,29,30,31,32,33,34,35	7,81
631 110 20	100 x 100 x 100 x 2,0	1,2,3,4,5,6,7,8,9,10,11,12,13,14,15,16,17,18	24,25,26,27,28,29,30,31,32,33,34,35,36,37,38,39,40,41,42,43,44,45	10,5
RHV 60	80 x 80 x 60 x 1,5	1,3,4,5	8,9,10,12	1,91
RHV 80	120 x 120 x 75 x 1,5	1,2,4,6,7,10	12,13,15,18,19,21,23,24	2,88

Table B.7: Basic Forces $F_{4,5}$, 2 angle brackets / connection

Bracket number	Bracket type	Nail number n_v	Nail number n_h	$F_{4,5,Rk}$ [kN]	
				Timber	Steel
633 553 20	50 x 50 x 30 x 2,0	1,2	5,6	4,09	1,14
633 753 20	70 x 50 x 30 x 2,0	1,2,3,4,5,6	7,8	4,28	1,14
633 853 25	80 x 50 x 30 x 2,5	1,2,3,4,5,6	9,10	4,15	1,52
631 460 25	40 x 40 x 60 x 2,5	1,2,3	6,7,8,9,10	7,22	3,20
631 480 25	40 x 40 x 80 x 2,5	1,2,3	8,9,10,11,12,13,14	10,6	4,77
631 640 25	60 x 60 x 40 x 2,5	1,2,3	6,7,8,9	3,56	2,49
631 650 25	60 x 60 x 50 x 2,5	1,2,3,4,5	8,9,10,11,12,13,14,15	7,18	2,97
631 660 25	60 x 60 x 60 x 2,5	1,2,3,4,5,6	10,11,12,13,14,15,16,17,18	7,40	3,86
631 680 25	60 x 60 x 80 x 2,5	1,2,3,4,5,6,7	12,13,14,15,16,17,18,19,20,21	8,50	5,07
631 610 25	60 x 60 x 100 x 2,5	1,2,3,4,5,6,7,8,9	15,16,17,18,19,20,21,22,23,24,25,26,27	11,4	6,31
631 480 25	80 x 80 x 40 x 2,5	1,2,3,4	7,8,9,10,11,12	4,04	2,59
631 860 25	80 x 80 x 60 x 2,5	1,2,3,4,5,6,7,8	11,12,13,14,15,16,17,18,19,20	8,11	3,98
631 880 25	80 x 80 x 80 x 2,5	1,2,3,4,5,6,7,8,9,10,11	15,16,17,18,19,20,21,22,23,24,25,26,27,28	11,0	5,27
631 810 25	80 x 80 x 100 x 2,5	1,2,3,4,5,6,7,8,9,10,11,12,13	19,20,21,22,23,24,25,26,27,28,29,30,31,32,33,34,35,36	12,7	4,75
631 160 25	100 x 100 x 60 x 2,5	1,2,3,4,5,6,7,8,9,10	14,15,16,17,18,19,20,21,22,23,24,25	7,36	3,88
631 180 25	100 x 100 x 80 x 2,5	1,2,3,4,5,6,7,8,9,10,11,12,13,14	18,19,20,21,22,23,24,25,26,27,28,29,30,31,32,33,34,35	6,01	3,96
631 110 25	100 x 100 x 100 x 2,5	1,2,3,4,5,6,7,8,9,10,11,12,13,14,15,16,17,18	24,25,26,27,28,29,30,31,32,33,34,35,36,37,38,39,40,41,42,43,44,45	13,2	7,64

Definitions of forces, their directions and eccentricity

Forces - Beam to beam connection

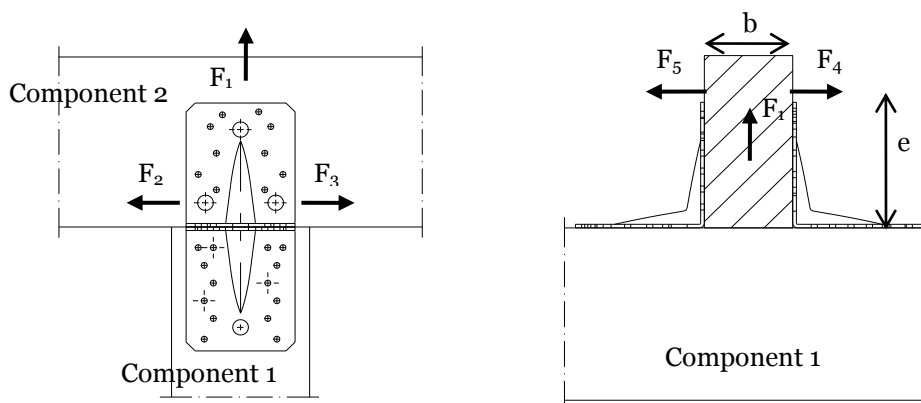

Fastener specification

Holes are marked with numbers referring to the nailing pattern in Annex B.

Double angle brackets per connection

The angle brackets must be placed at each side opposite to each other, symmetrically to the component axis.

Acting forces

- F_1 Lifting force acting along the central axis of the joint.
- F_2 and F_3 Lateral force acting in the joint between the component 2 and component 1 in the component 2 direction
- F_4 and F_5 Lateral force acting in the component 1 direction along the central axis of the joint. If the load is applied with an eccentricity e , a design for combined loading is required.

Single angle bracket per connection

Acting forces

- F_1 Lifting force acting in the central axis of the angle bracket. The component 2 shall be prevented from rotation. If the component 2 is prevented from rotation the load-carrying capacity will be half of a connection with double angle brackets.
- F_2 and F_3 Lateral force acting in the joint between the component 2 and the component 1 in the component 2 direction. The component 2 shall be prevented from rotation. If the component 2 is prevented from rotation the load-carrying capacity will be half of a connection with double angle brackets.
- F_4 and F_5 Lateral force acting in the component 1 direction in the height of the top edge of component 2. F_4 is the lateral force towards the angle bracket; F_5 is the lateral force away from the angle bracket. Only the characteristic load-carrying capacities for angle brackets with ribs are given.

Wane

Wane is not allowed, the timber has to be sharp-edged in the area of the angle brackets.

Timber splitting

For the lifting force F_1 it must be checked in accordance with Eurocode 5 or a similar national Timber Code that splitting will not occur.

Connection to timber, concrete or steel with a bolt or metal anchor

The tensile load $F_{B,Ed}$ for the design of a bolt or metal anchor is calculated as:

$$F_{B,t,Ed} = k_t \cdot F_{Ed} \text{ for tensile load}$$

$$F_{B,v,Ed} = F_{Ed} \text{ for shear load}$$

Where:

$F_{B,t,Ed}$	Bolt tensile load in N
$F_{B,v,Ed}$	Bolt shear load in N
k_t	Coefficient taking into account the moment arm ($k_t = 1 + e/z$)
F_{Ed}	Load on vertical flap of the angle bracket in N

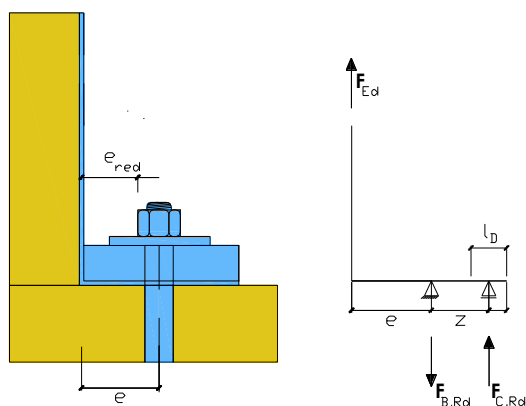

Combined forces

If the forces F_1 and F_2/F_3 or F_4/F_5 act at the same time, the following inequality shall be fulfilled:

$$\left(\frac{F_{1,d}}{F_{Rd,1}}\right)^2 + \left(\frac{F_{2,d}}{F_{Rd,2}}\right)^2 + \left(\frac{F_{3,d}}{F_{Rd,3}}\right)^2 + \left(\frac{F_{4,d}}{F_{Rd,4}}\right)^2 + \left(\frac{F_{5,d}}{F_{Rd,5}}\right)^2 \leq 1$$

The forces F_2 and F_3 or F_4 and F_5 are forces with opposite direction. Therefore only one force F_2 or F_3 , and F_4 or F_5 , respectively, is able to act simultaneously with F_1 , while the other shall be set to zero.

If the load F_4/F_5 is applied with an eccentricity e , a design for combined loading **for connections with double angle brackets** is required. Here, an additional force ΔF_1 has to be added to the existing force F_1 .

$$\Delta F_{1,d} = F_{4,d} / F_{5,d} \cdot \frac{e}{B}$$

B is the width of component 2.

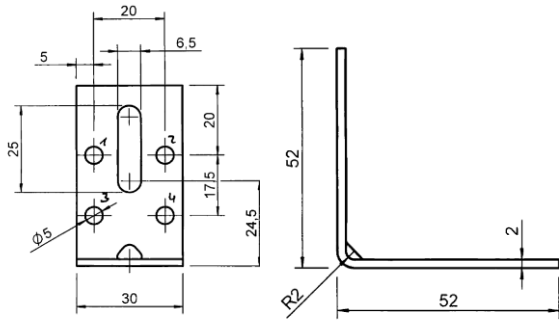

Figure B. 1 Dimensions of Angle Bracket 633 553 20

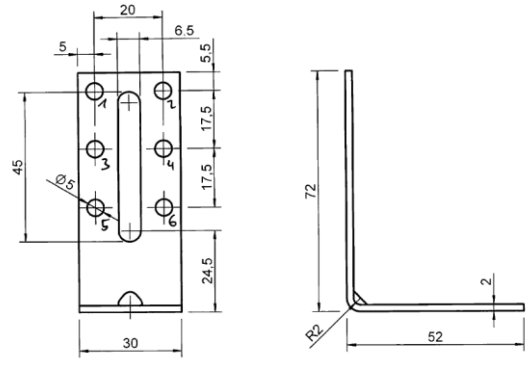

Figure B. 2 Dimensions of Angle Bracket 633 753 20

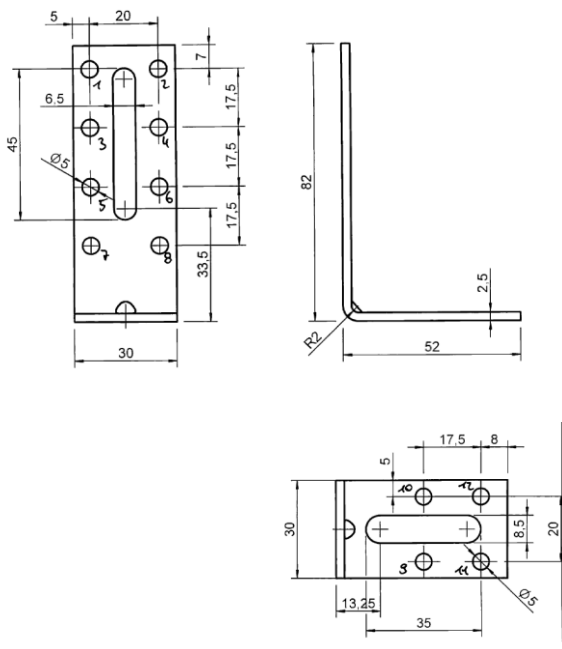
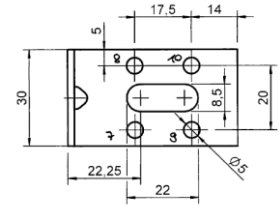
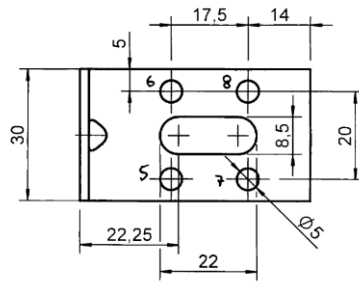

Figure B. 3 Dimensions of Angle Bracket 633 853 25

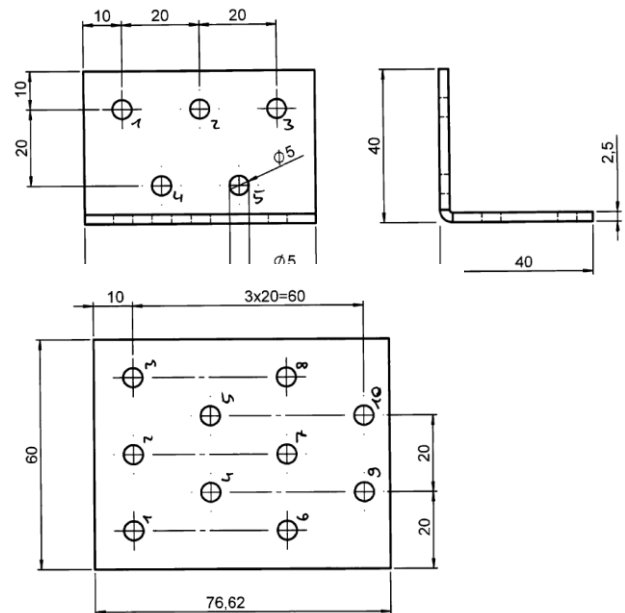

Figure B. 4 Dimensions of Angle Bracket 631 460 25

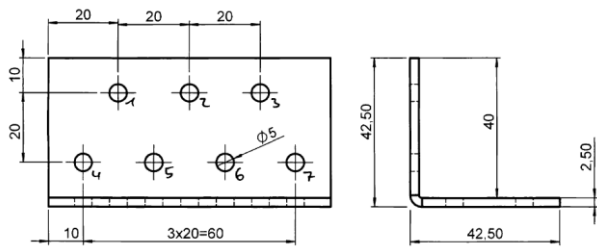

Figure B. 5 Dimensions of Angle Bracket 631 480 25

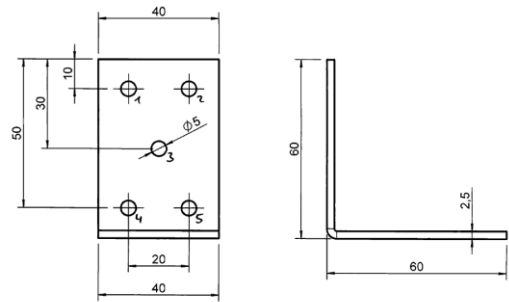

Figure B. 6 Dimensions of Angle Bracket 631 640 25

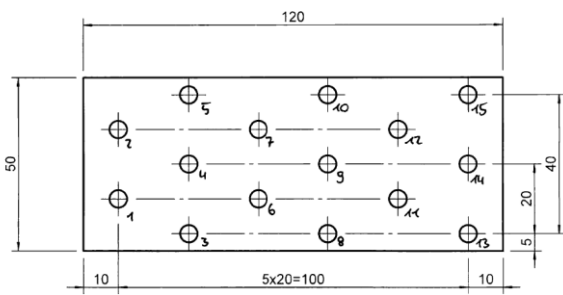
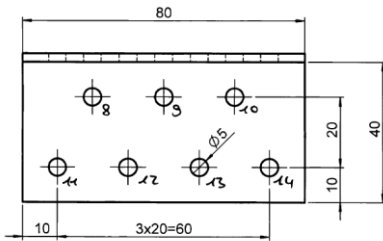

Figure B. 7 Dimensions of Angle Bracket 631 650 25

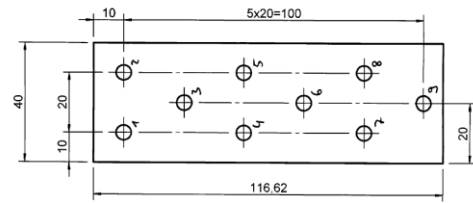
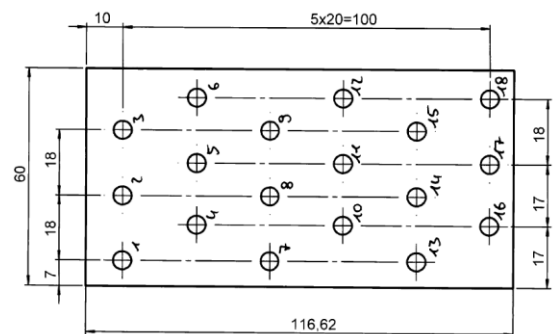
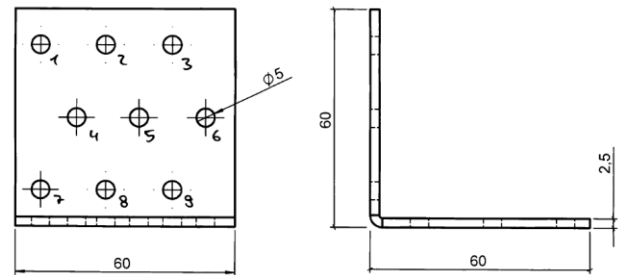

Figure B. 8 Dimensions of Angle Bracket 631 660 25



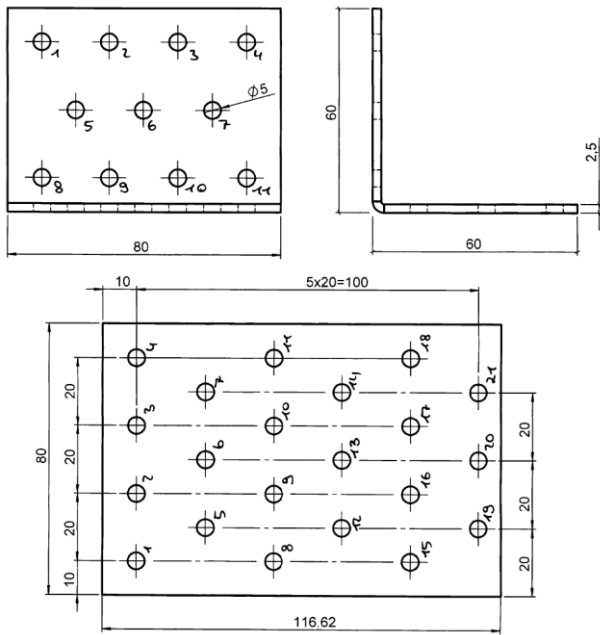

Figure B. 9 Dimensions of Angle Bracket 631 680 25

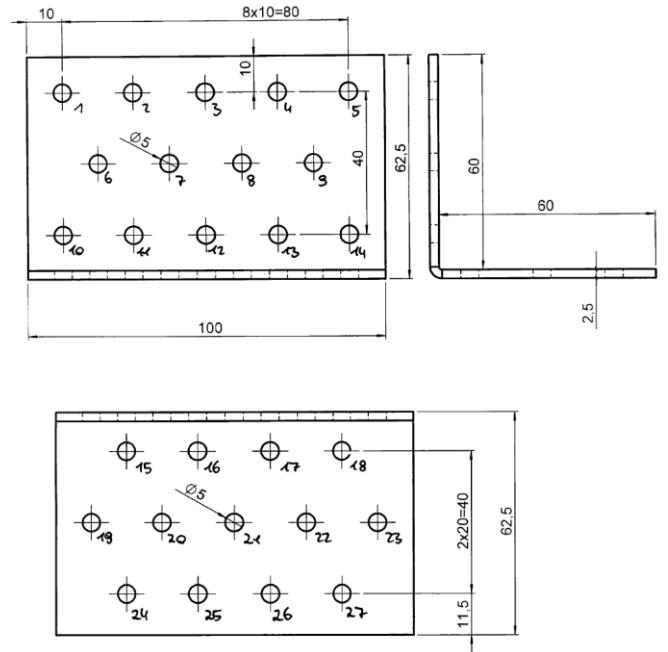

Figure B. 10 Dimensions of Angle Bracket 631 610 25

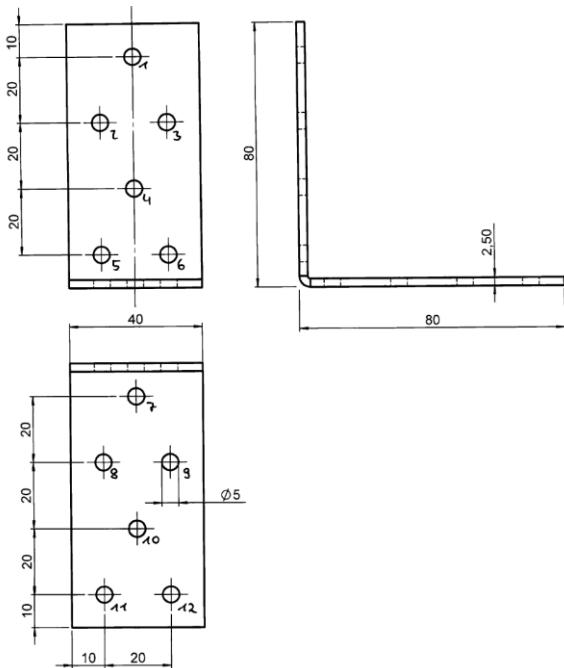

Figure B. 11 Dimensions of Angle Bracket 631 480 25

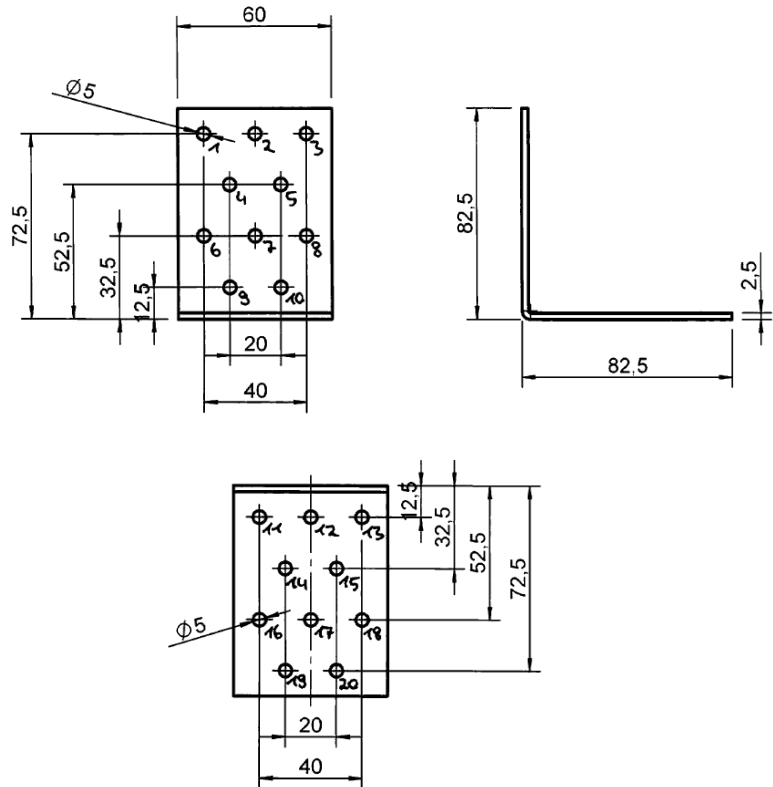

Figure B. 12 Dimensions of Angle Bracket 631 860 25

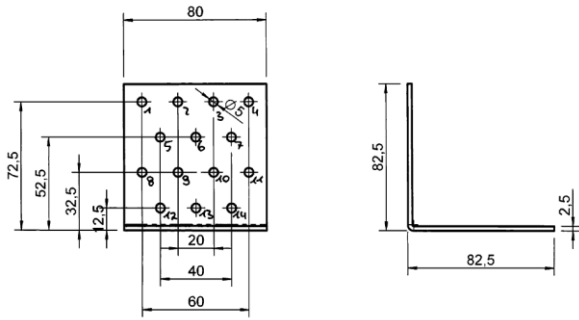

Figure B. 13 Dimensions of Angle Bracket 631 880 25

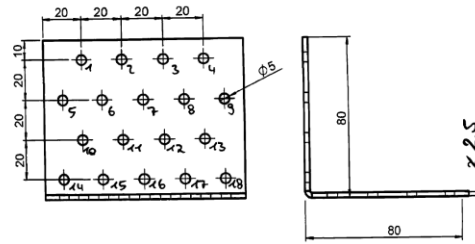

Figure B. 14 Dimensions of Angle Bracket 631 810 25

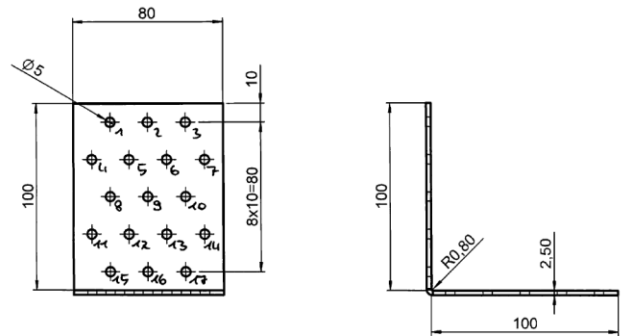
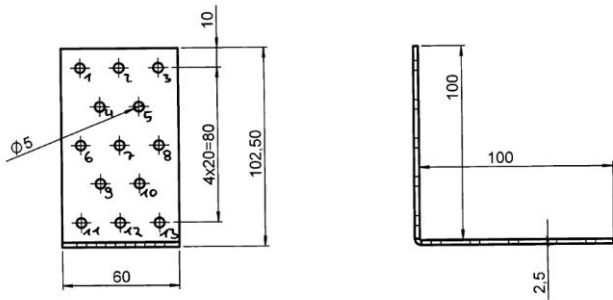
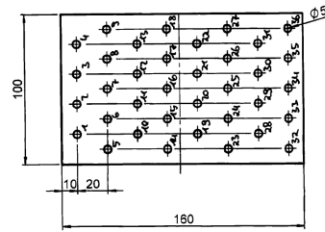
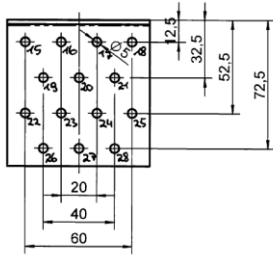
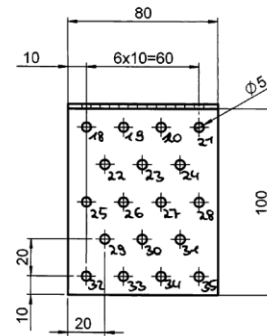
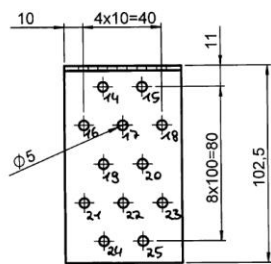

Figure B. 15 Dimensions of Angle Bracket 631 160 25

Figure B. 16 Dimensions of Angle Bracket 631 180 25



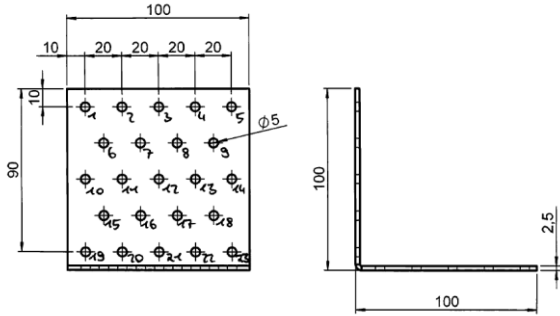

Figure B. 17 Dimensions of Angle Bracket 631 110 25

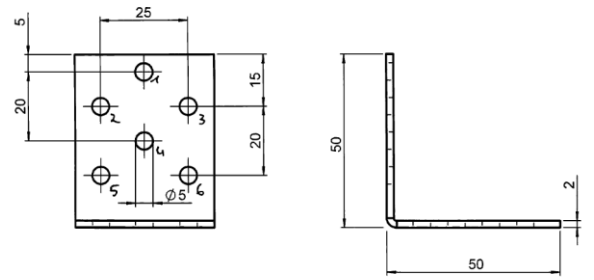

Figure B. 18 Dimensions of Angle Bracket 631 554 20

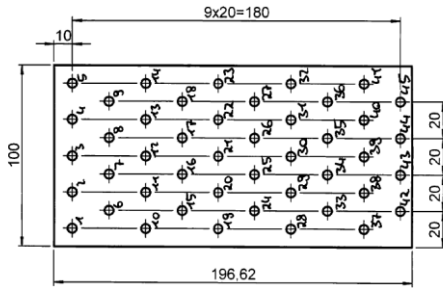

Figure B. 19 Dimensions of Angle Bracket 634 100

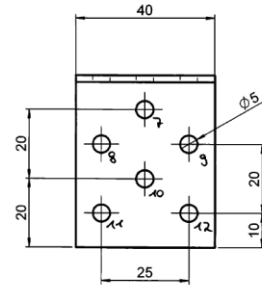

Figure B. 20 Dimensions of Angle Bracket 634 150 20

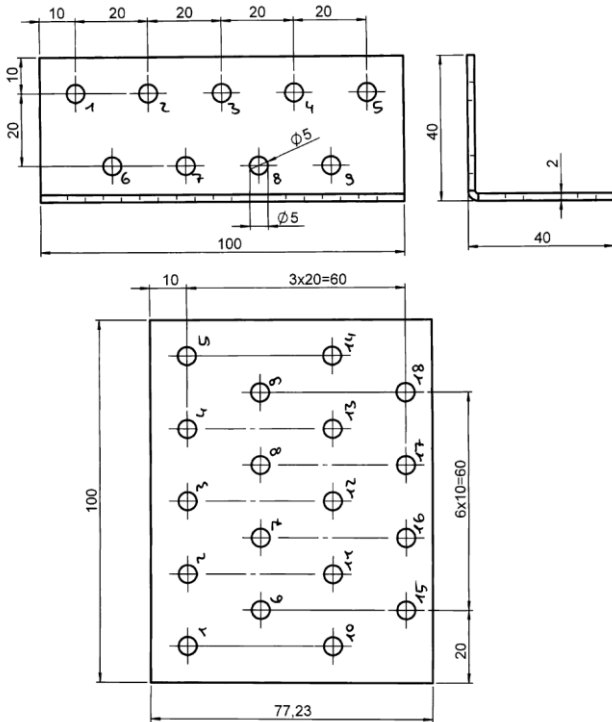

Figure B. 19 Dimensions of Angle Bracket 634 100

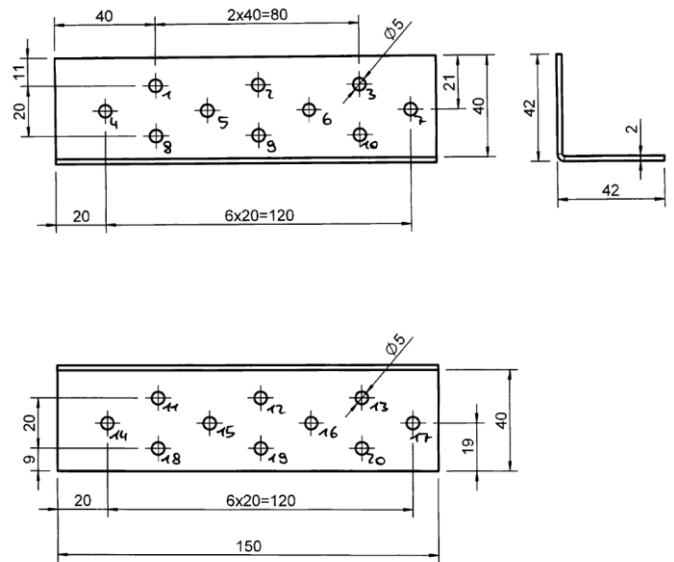

Figure B. 20 Dimensions of Angle Bracket 634 150 20

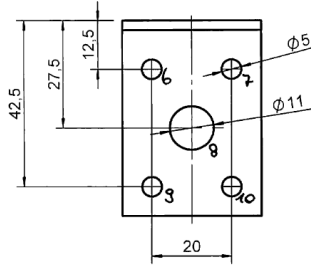
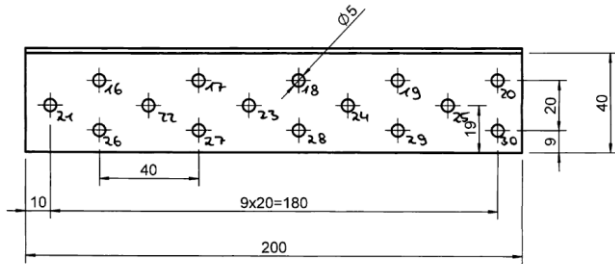
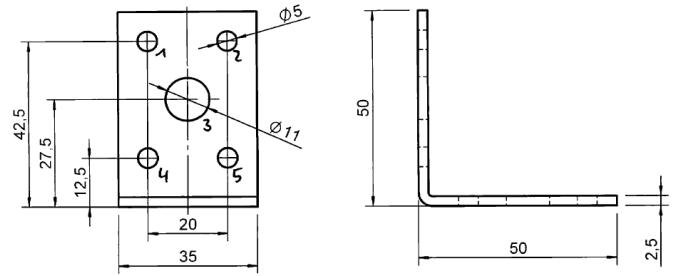
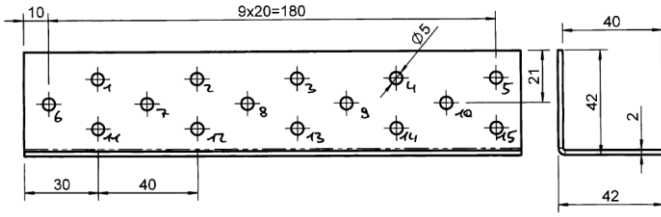

Figure B. 21 Dimensions of Angle Bracket 631 200 20

Figure B. 22 Dimensions of Angle Bracket 641 035 25

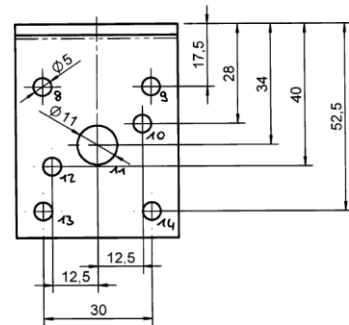
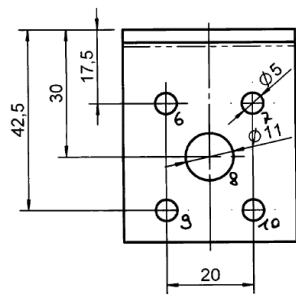
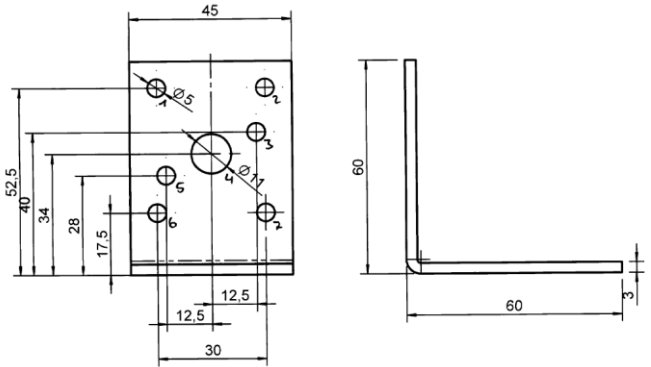
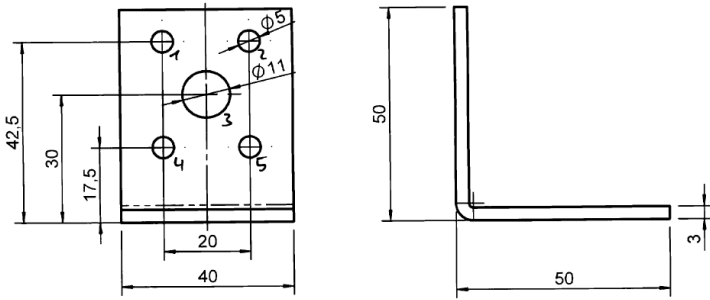

Figure B. 23 Dimensions of Angle Bracket 641 040 30

Figure B. 24 Dimensions of Angle Bracket 641 664 30

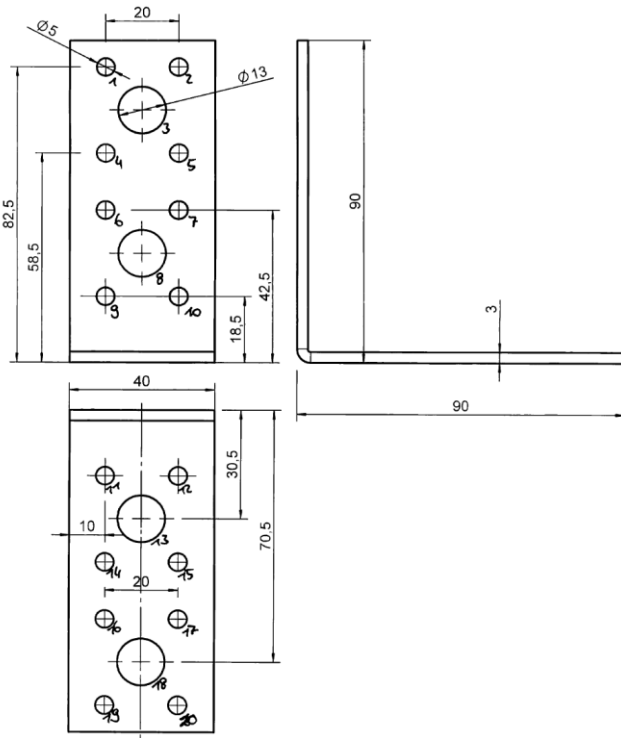

Figure B. 25 Dimensions of Angle Bracket 641 994 30

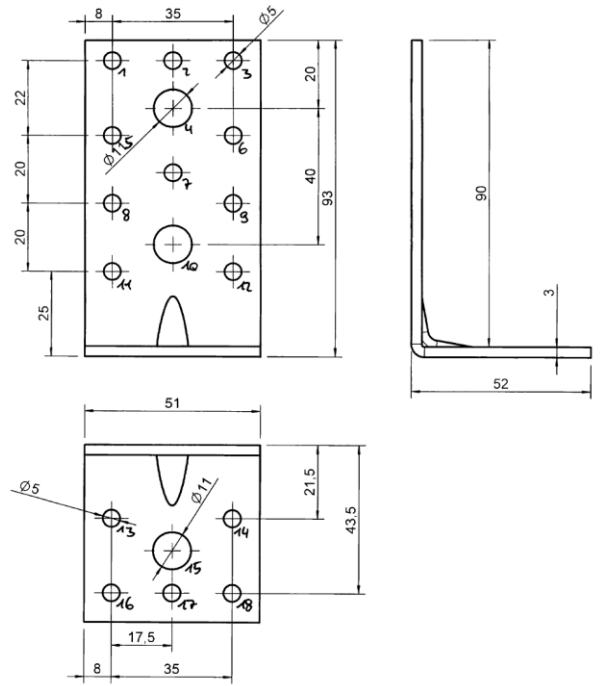

Figure B. 26 Dimensions of Angle Bracket 641 595 30

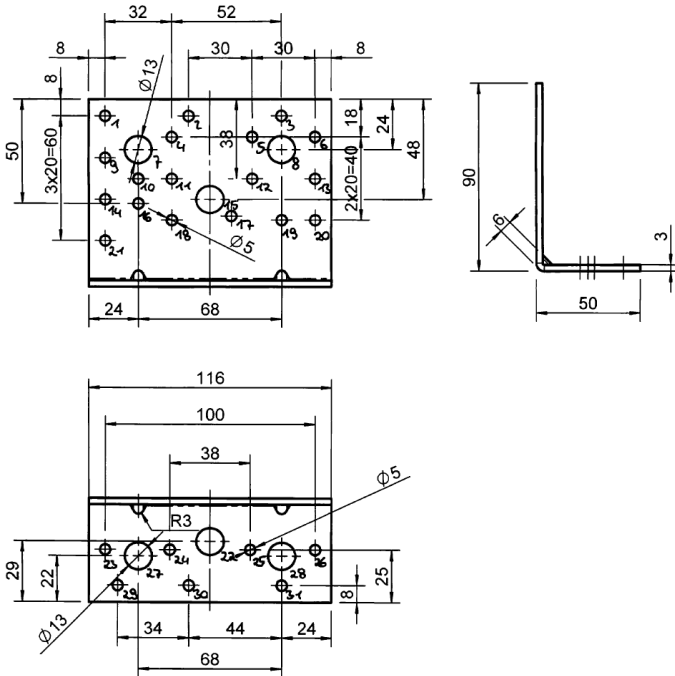

Figure B. 27 Dimensions of Angle Bracket 500 313 62

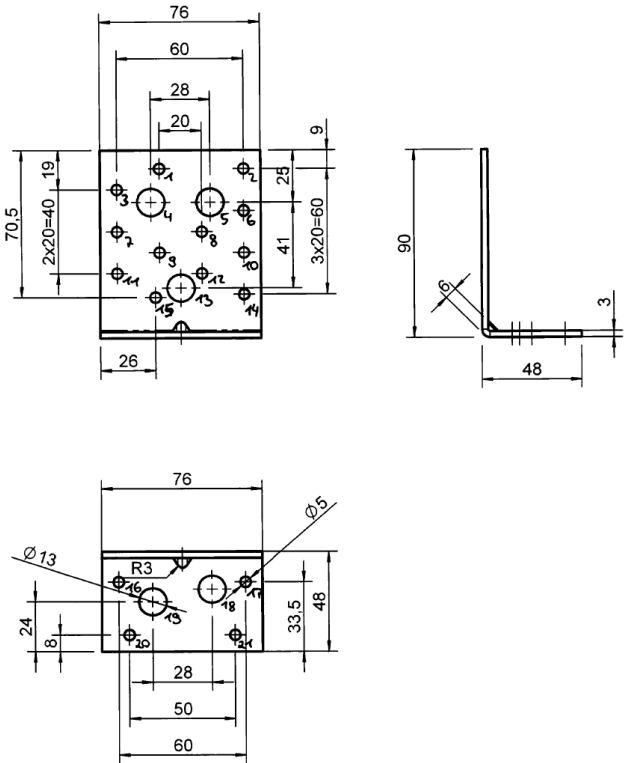

Figure B. 28 Dimensions of Angle Bracket 641 598 30

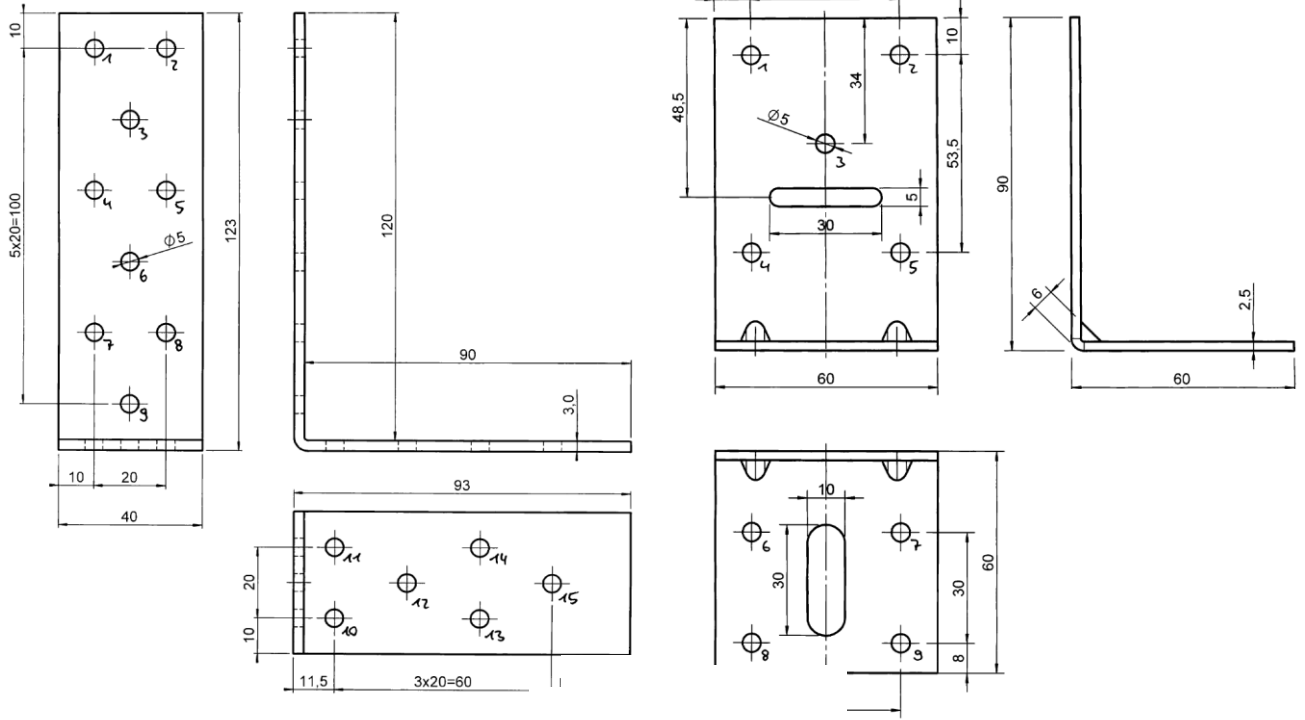

Figure B. 29 Dimensions of Angle Bracket 641 912 30

sions of Angle Brack

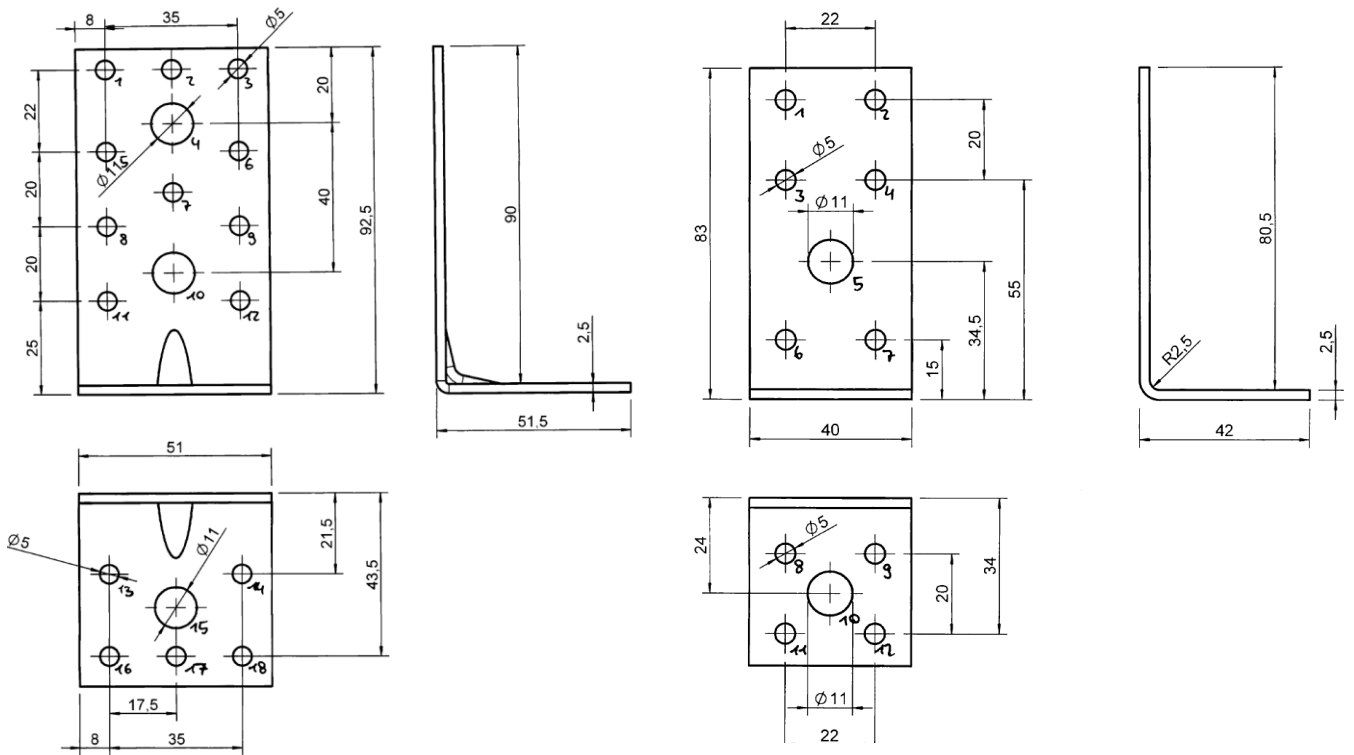

Figure B. 31 Dimensions of Angle Bracket 641 590 30

Figure B. 32 Dimensions of Angle Bracket 641 490 25

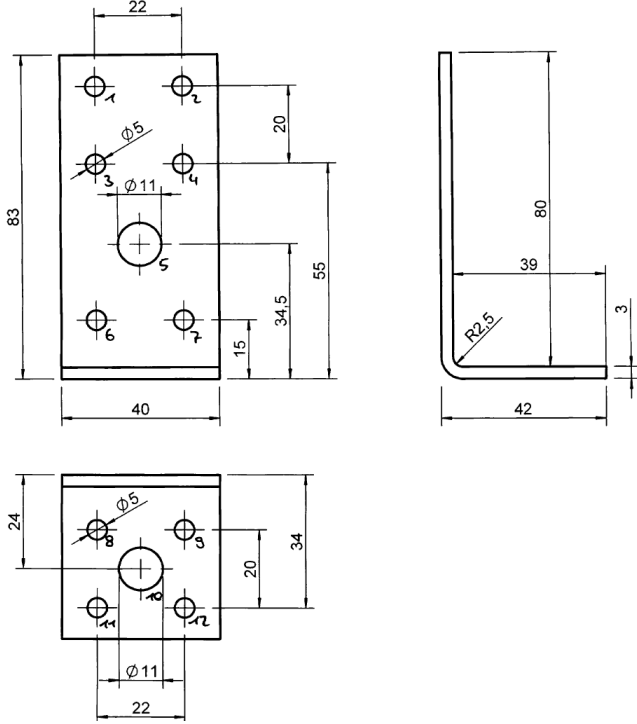

Figure B. 33 Dimensions of Angle Bracket 641 490 30

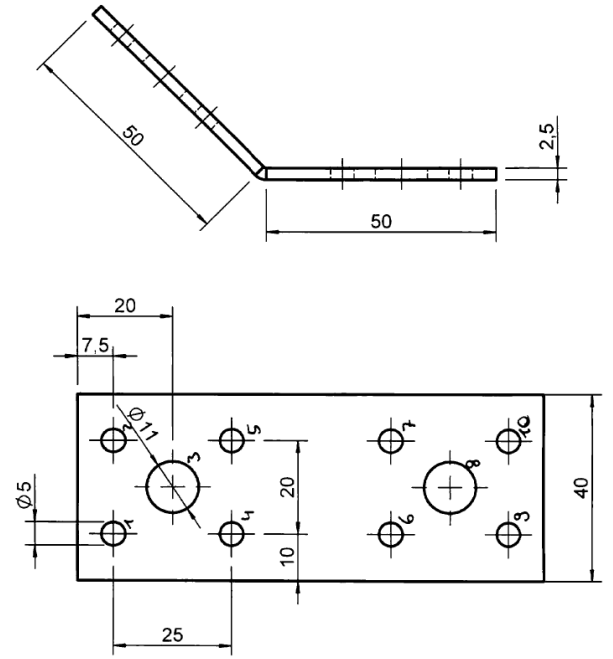

Figure B. 34 Dimensions of Angle Bracket 651 554 25

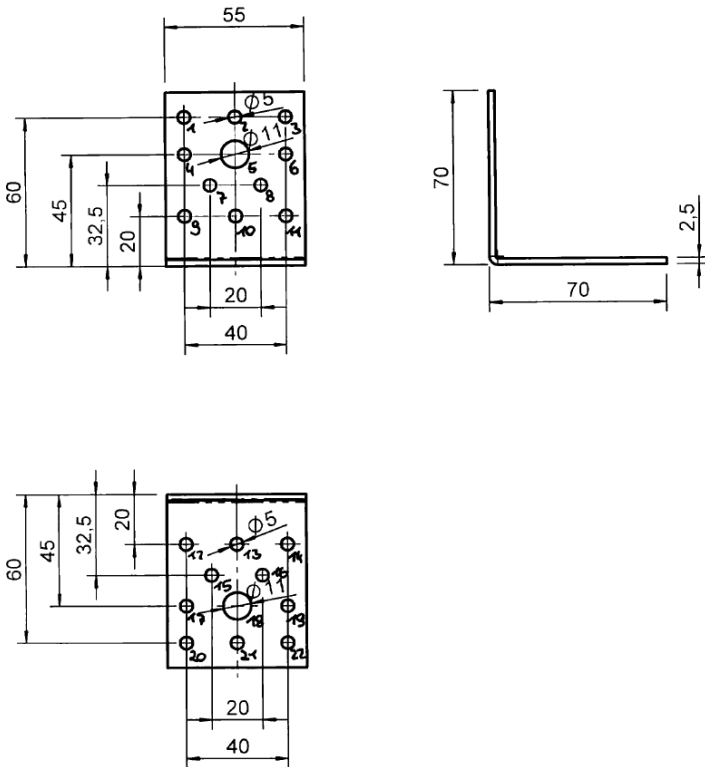

Figure B. 35 Dimensions of Angle Bracket 651 070 25

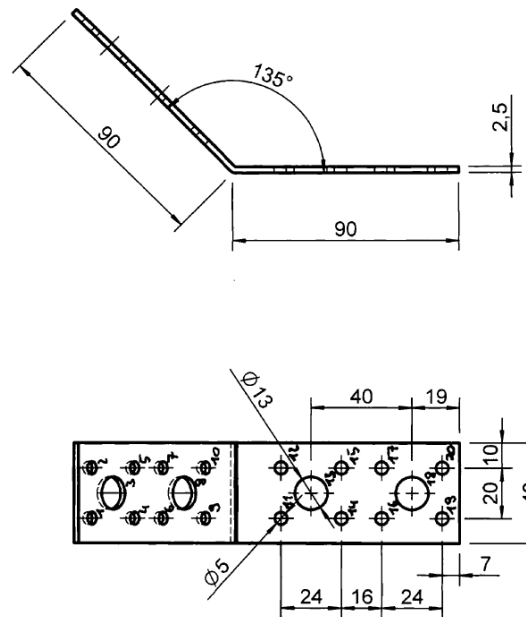

Figure B. 36 Dimensions of Angle Bracket 651 994 25

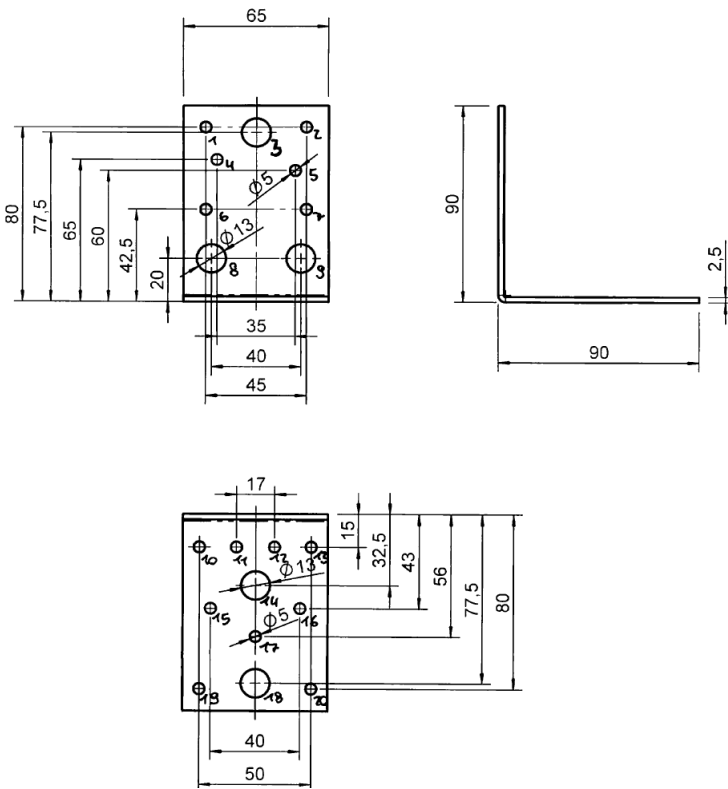

Figure B. 37 Dimensions of Angle Bracket 651 090 25

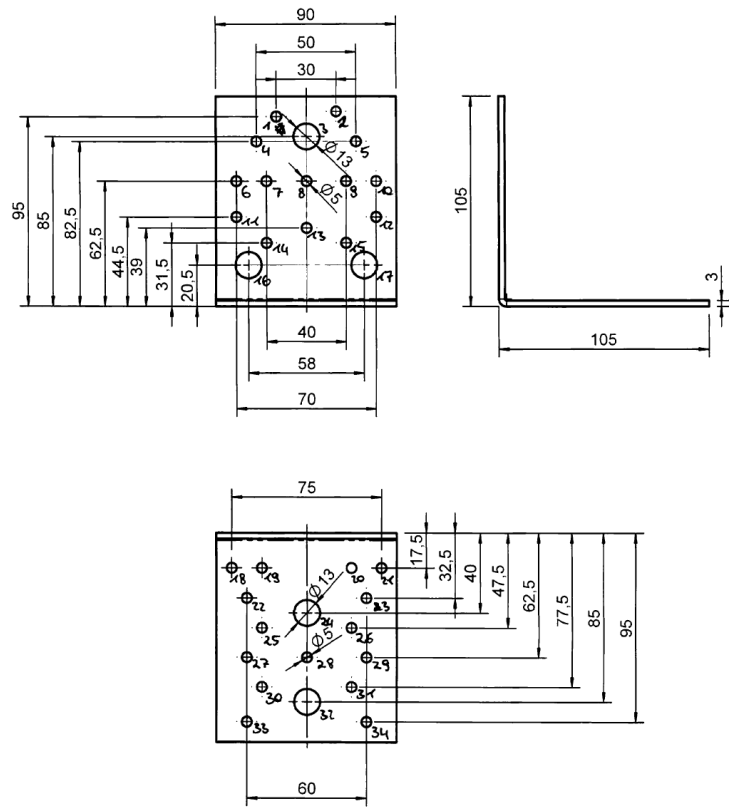

Figure B. 38 Dimensions of Angle Bracket 651 105 30

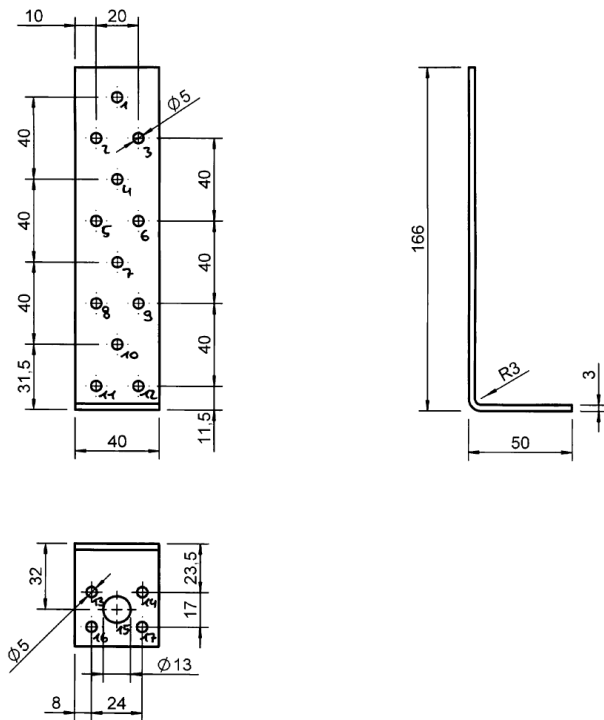

Figure B. 39 Dimensions of Angle Bracket 641 416 40

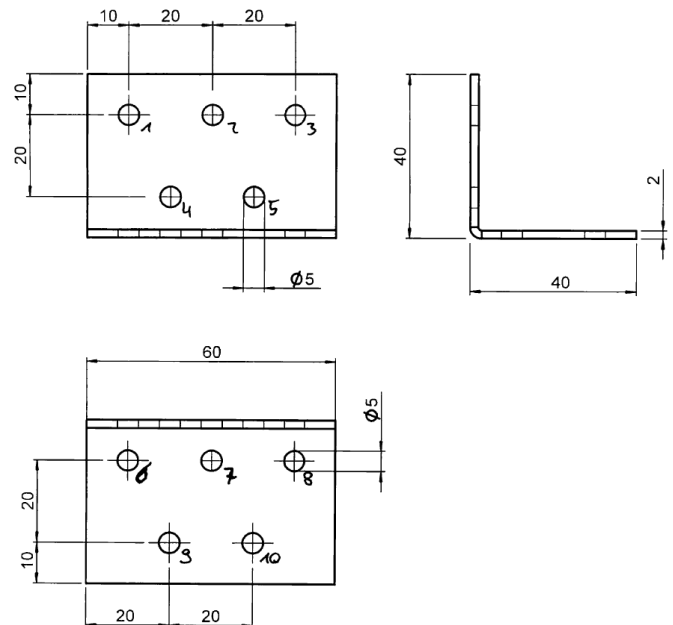

Figure B. 40 Dimensions of Angle Bracket 631 460 20

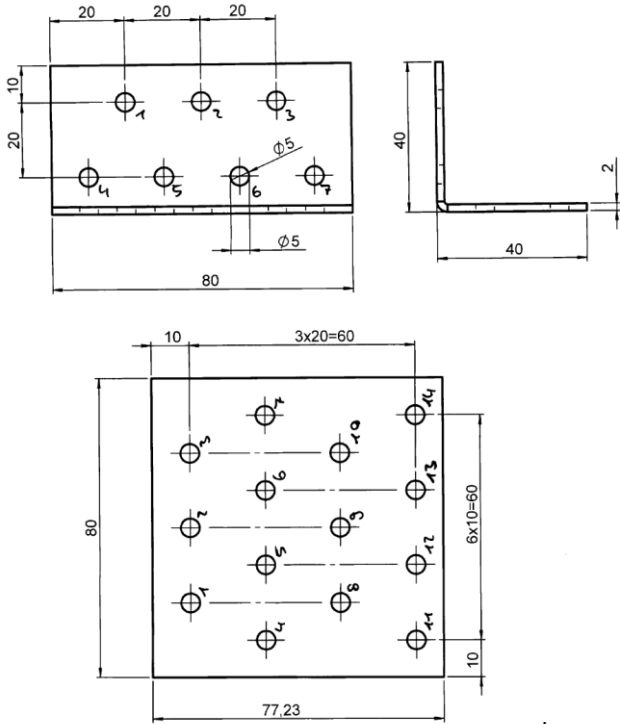

Figure B. 41 Dimensions of Angle Bracket 631 480 20

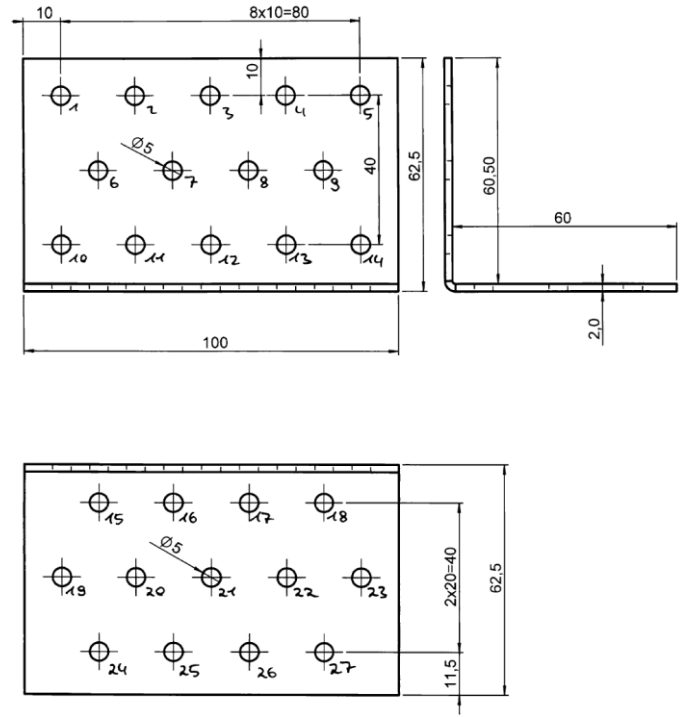

Figure B. 42 Dimensions of Angle Bracket 631 610 20

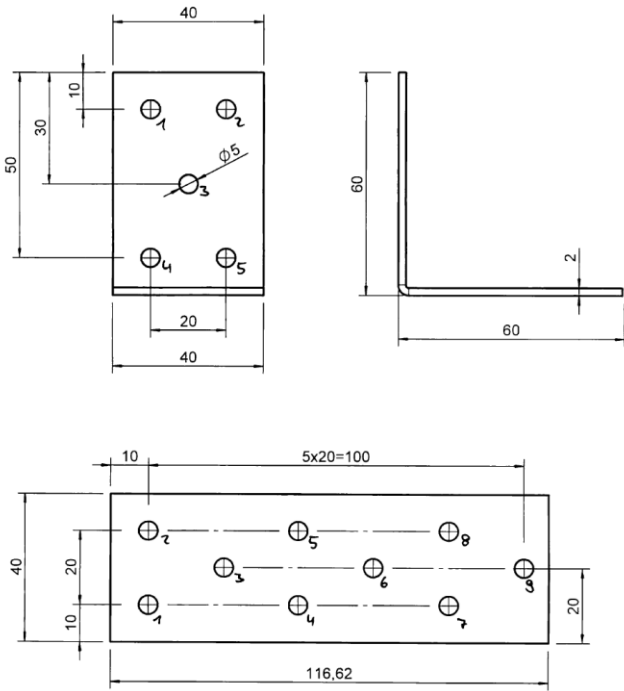

Figure B. 43 Dimensions of Angle Bracket 631 640 20

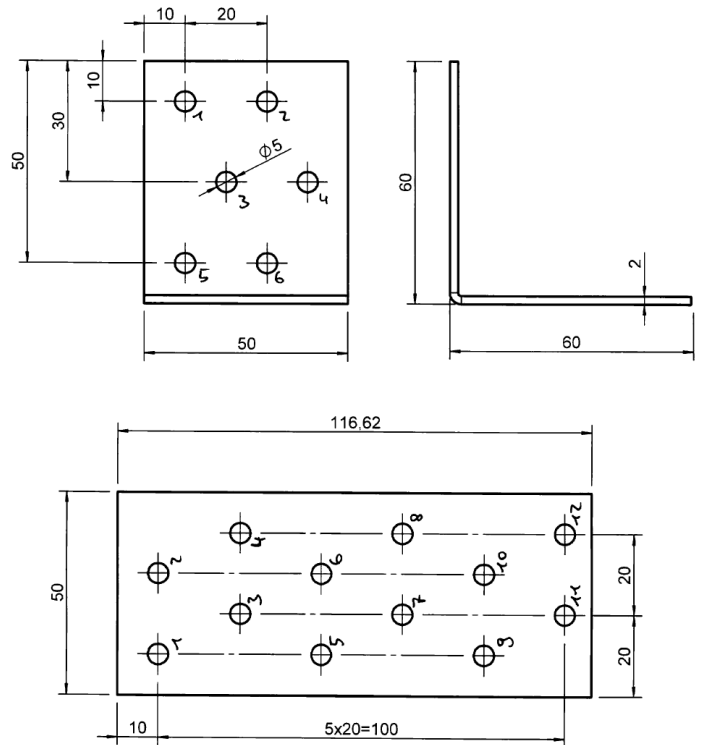

Figure B. 44 Dimensions of Angle Bracket 631 650 20

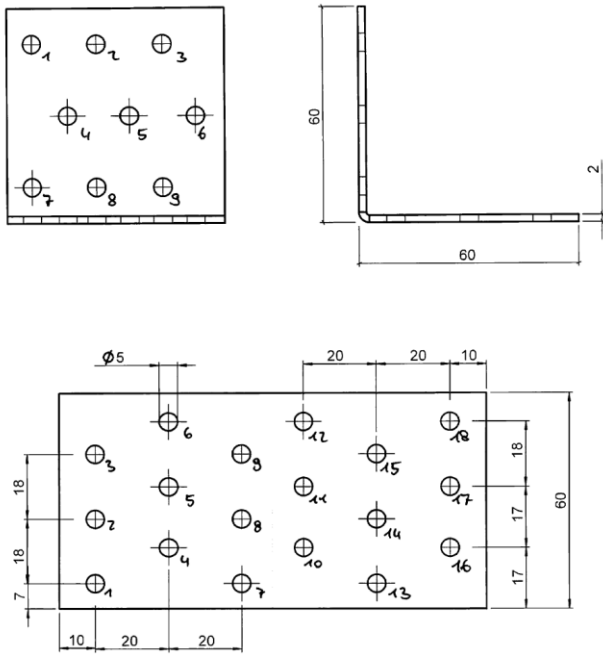

Figure B. 45 Dimensions of Angle Bracket 631 660 20

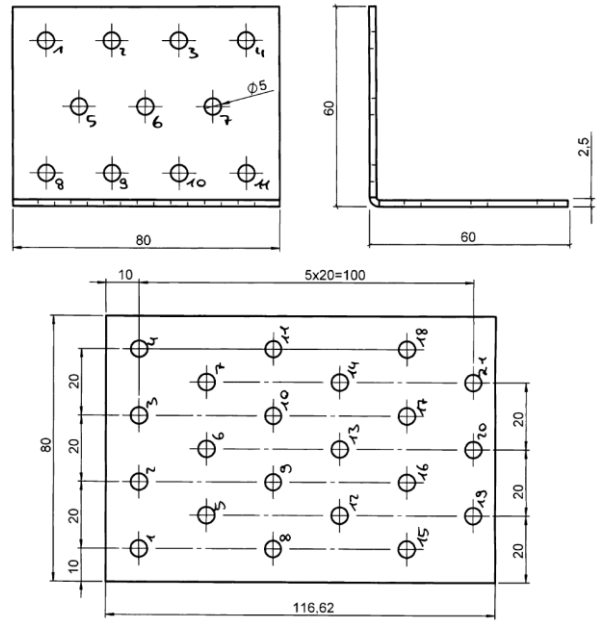

Figure B. 46 Dimensions of Angle Bracket 631 680 20

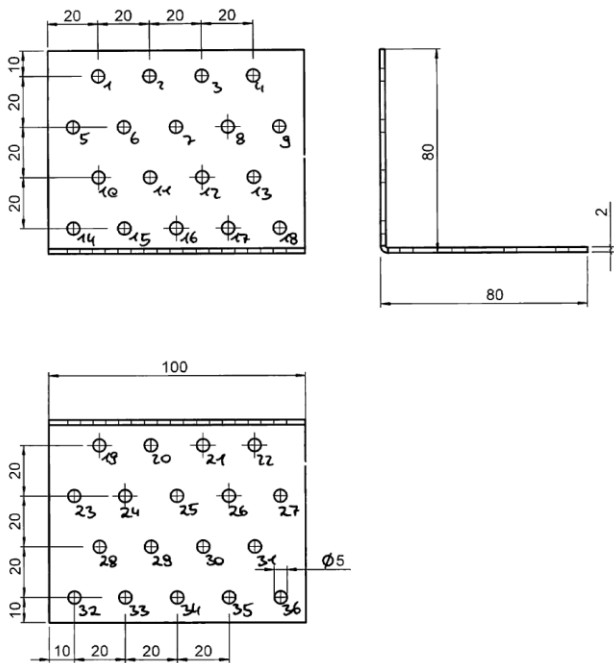

Figure B. 47 Dimensions of Angle Bracket 631 810 20

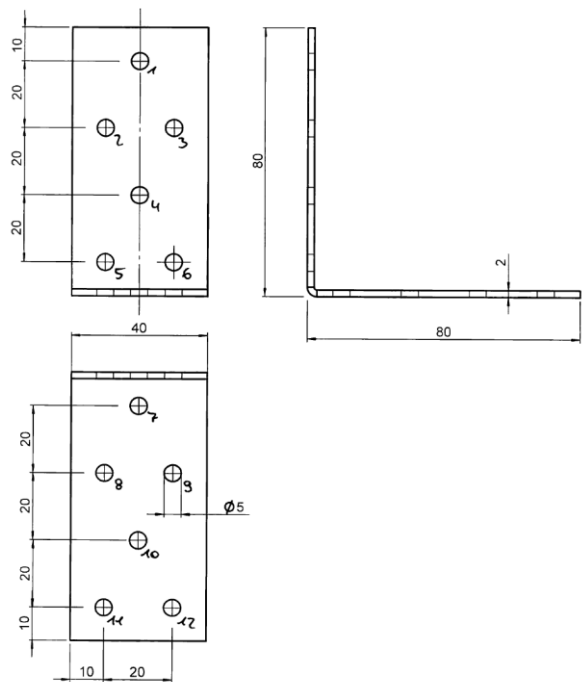

Figure B. 48 Dimensions of Angle Bracket 631 480 20

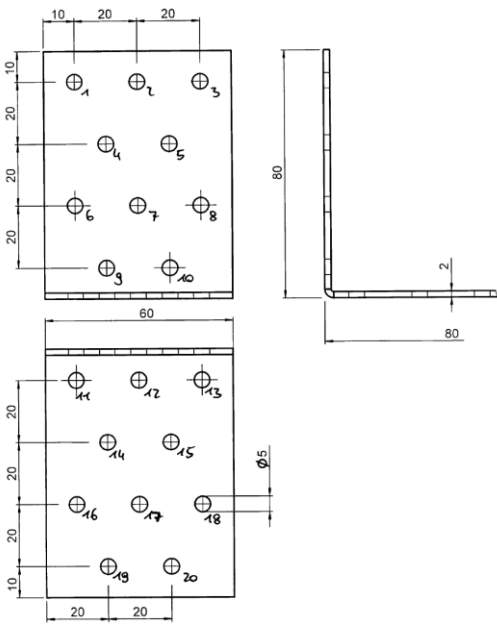

Figure B. 49 Dimensions of Angle Bracket 631 860 20

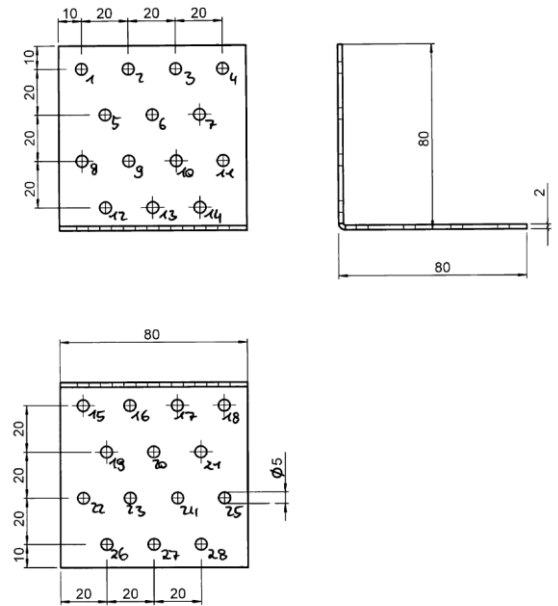

Figure B. 50 Dimensions of Angle Bracket 631 880 20

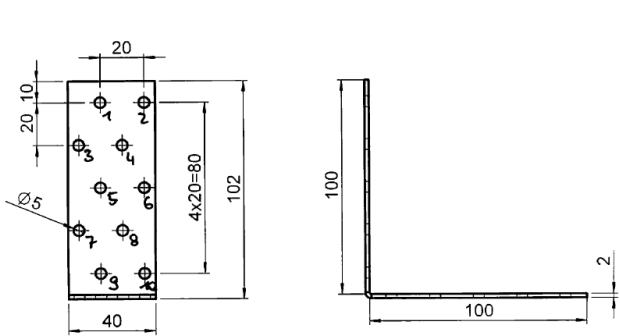

Figure B. 51 Dimensions of Angle Bracket 631 140 20

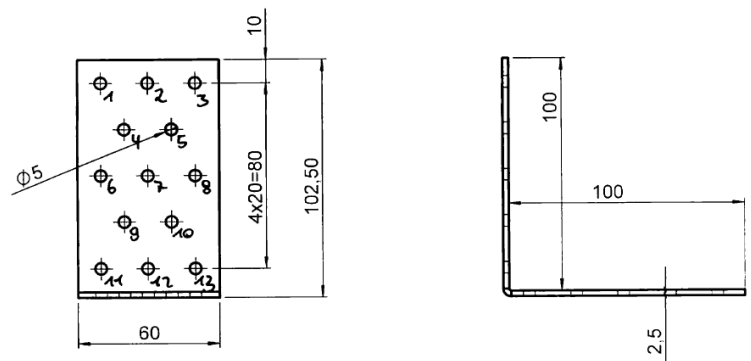
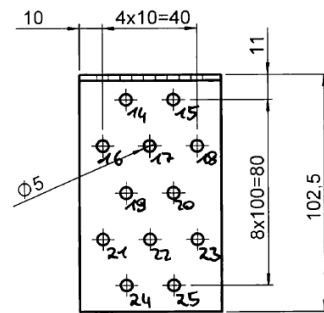
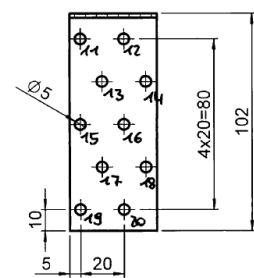

Figure B. 52 Dimensions of Angle Bracket 631 160 20



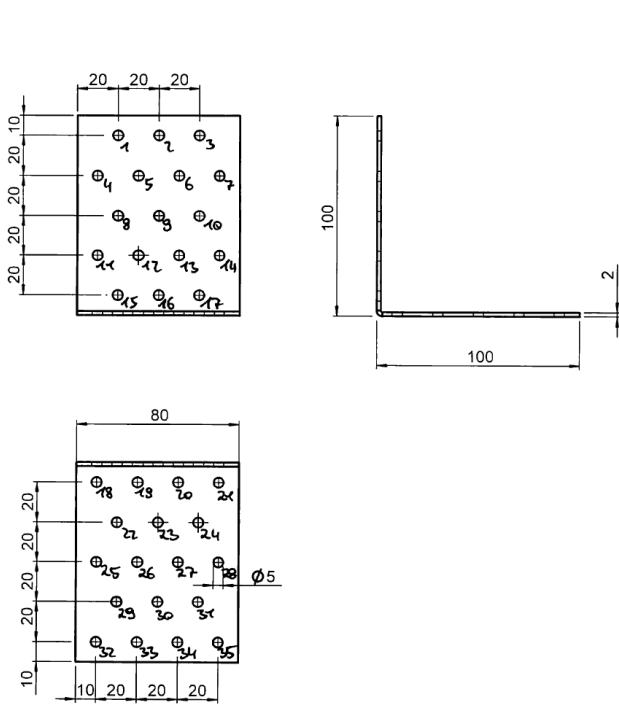

Figure B. 53 Dimensions of Angle Bracket 631 180 20

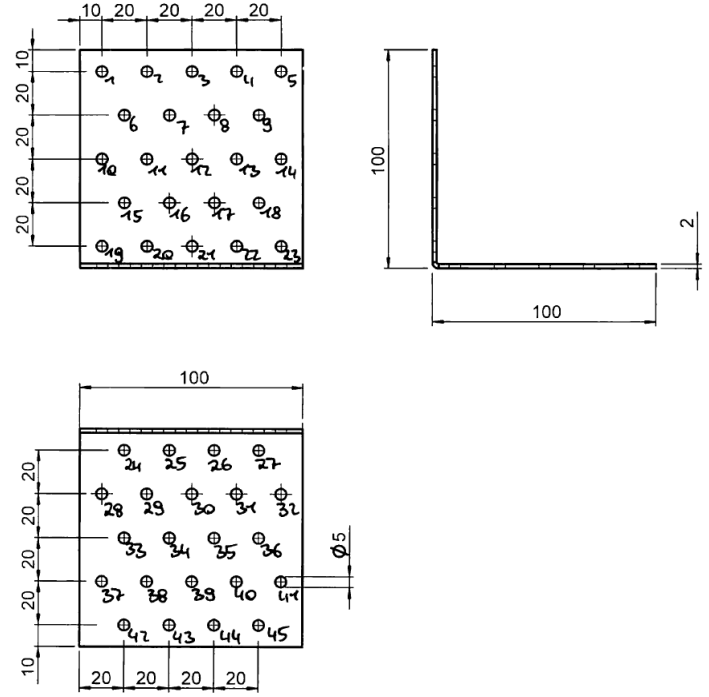

Figure B. 54 Dimensions of Angle Bracket 631 110 20

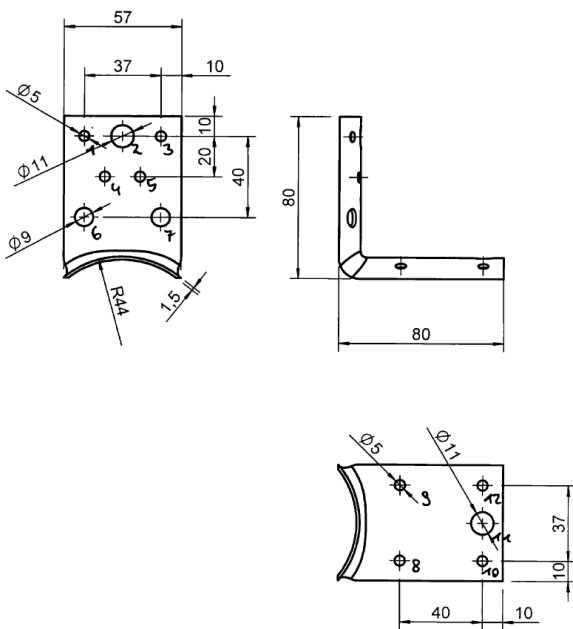

Figure B. 55 Dimensions of Angle Bracket RHV 60

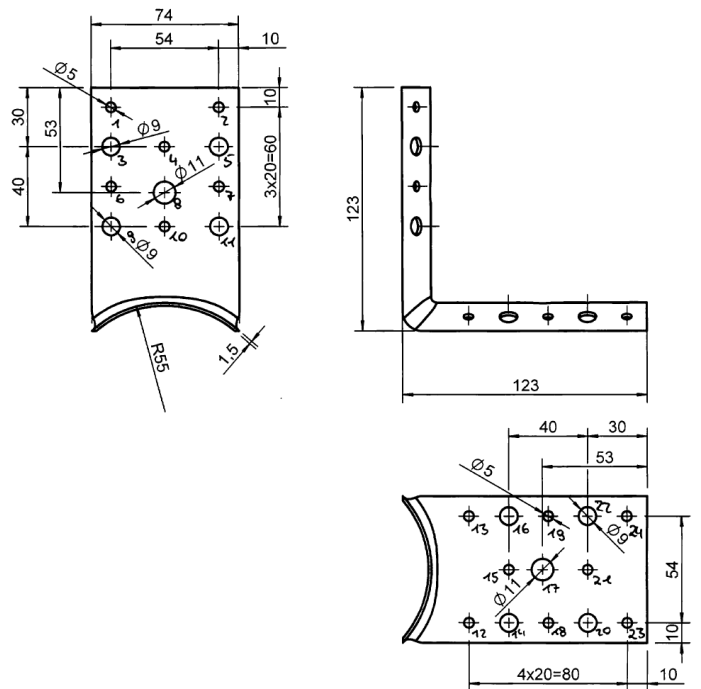

Figure B. 56 Dimensions of Angle Bracket RHV 80

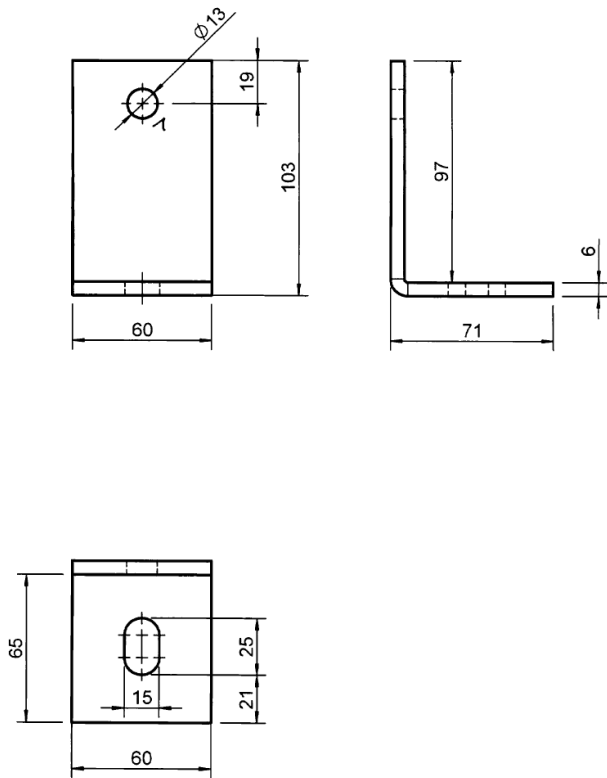

Figure B. 57 Dimensions of Angle Bracket 633 710 66

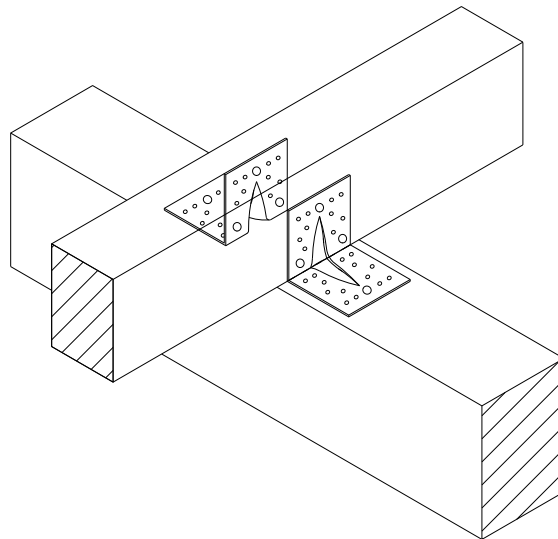

Figure B. 58 Typical installation