

Cim 17CR

FULLTLØP KULEVENTIL - PN 32 - TYPE T16 - STÅL SPAK - CR MESSING



Denne artikkelen er produsert i overensstemmelse med kvalitetssikringskravene i ISO 9001:2008 standard. Alle artikler er testet i henhold til EN12266-1:2003 standard.

Den kan brukes på et stort utvalg områder: Varme, kjøling, vann, pneumatiske systemer, olje, bensin, mettet damp og generelt med ethvert ikke-aggressivt medie.

Den garanteres i 5 år.

Den er produsert i en messinglegering i henhold til standard EN 12165-CW602N-M.

Nominelt trykk: PN32

Arbeidstemperatur: -20 til 150°C

MENGDE OG TRYKKTAP

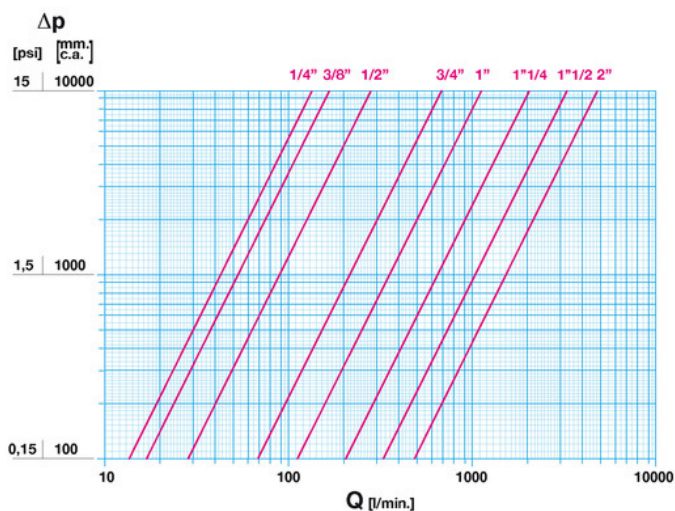

Noter:
 1 l/min = 0,06 m3/h
 1 m3/h = 16,67 l/min
 1 bar = 10.000 mm w.c.
 1 psi = 690 mm w.c.

TRYKK OG TEMPERATUR TABELL

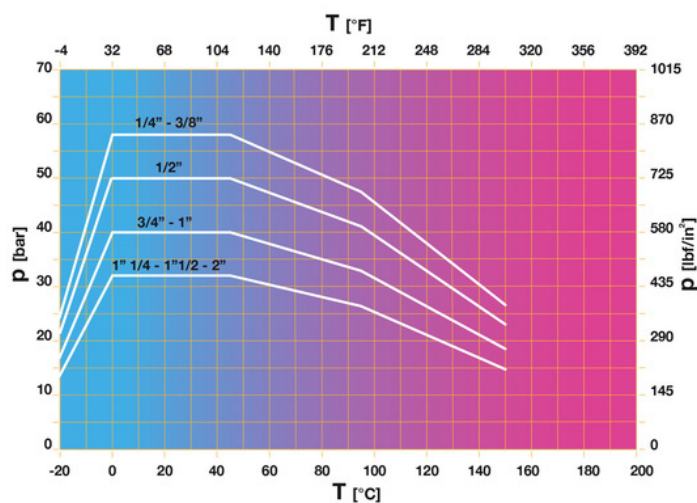

1 bar = 14,5 psi
 1 bar = 14,5 lbf/in2
 $^{\circ}\text{C} = 5/9 \times (^{\circ}\text{F} - 32)$
 $^{\circ}\text{F} = 32 + (9/5 \times ^{\circ}\text{C})$

TEKNISK TEGNING

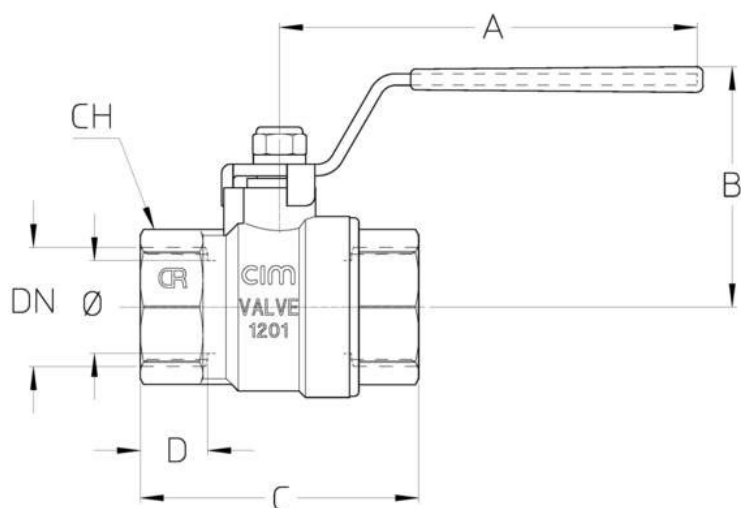

DN	1/4"	3/8"	1/2"	3/4"	1"	1"1/4"	1"1/2"	2"
Φ mm	10	10	15	20	25	32	40	50
Grms.	115	120	185	280	465	710	1060	1590
A	65	65	90	90	110	110	150	150
B	33	33	47	52	56,5	65,5	81	88
C	45	47	55	60	74	81	95	112
D	11,5	12,5	14	14,5	17	17,5	18	20
CH	18	20	25	31	38	47	54	66

Gjenget:
ISO 7 - Rp

På forespørsel:
ISO 7 - Rc
ANSI B1.20.1 - NPT

TEKNISKE EGENSKAPER

KV CM CS MT								
DN	1/4"	3/8"	1/2"	3/4"	1"	1"1/4"	1"1/2"	2"
Ø mm	10	10	15	20	25	32	40	50
KV	8	10	17	41	68	123	198	290
CM	1	1	1,5	2	4	5	8	11
CS	2	2	3	4	7	10	16	20
MT	10	10	24	24	26	26	88	88

KV = Kapasitet i m³/h ved 1 bar trykfall.

CM = Arbeidsmoment i Nm.

CS = Startmoment i Nm.

MT = Spindels bruddmoment i Nm.

VÅRE SERTIFIKATER

