

DE	Gebrauchsanleitung / Montageanleitung	2
FR	Mode d'emploi / Instructions de montage	4
EN	Instructions for use / assembly instructions	6
IT	Istruzioni per l'uso / Istruzioni per Installazione	8
ES	Modo de empleo / Instrucciones de montaje	10
NL	Gebruiksaanwijzing / Handleiding	12
DK	Brugsanvisning / Monteringsvejledning	14
PT	Instruções para uso / Manual de Instalação	16
PL	Instrukcja obsługi / Instrukcja montażu	18
CS	Návod k použití / Montážní návod	20
SK	Návod na použitie / Montážny návod	22
ZH	用户手册 / 组装说明	24
RU	Руководство пользователя / Инструкция по монтажу	26
HU	Használati útmutató / Szerelési útmutató	28
FI	Käyttöohje / Asennusohje	30
SV	Bruksanvisning / Monteringsanvisning	32
LT	Vartotojo instrukcija / Montavimo instrukcijos	34
HR	Upute za uporabu / Uputstva za instalaciju	36
TR	Kullanım kılavuzu / Montaj kılavuzu	38
RO	Manual de utilizare / Instrucțiuni de montare	40
EL	Οδηγίες χρήσης / Οδηγία συναρμολόγησης	42
SL	Navodilo za uporabo / Navodila za montažo	44
ET	Kasutusjuhend / Paigaldusjuhend	46
LV	Lietošanas pamācība / Montāžas instrukcija	48
SR	Uputstvo za upotrebu / Uputstvo za montažu	50
NO	Bruksanvisning / Montasjeveiledning	52
BG	Инструкция за употреба / Ръководство за монтаж	54
SQ	Udhëzuesi i përdorimit / Udhëzime rreth montimit	56
AR	دليل الاستخدام / تعليمات التجميع	59

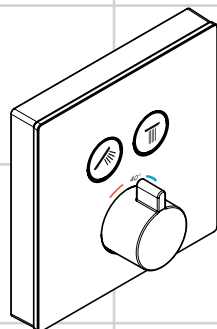

ShowerSelect
15738400 / 15738600

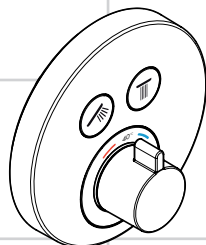

ShowerSelect S
15743000

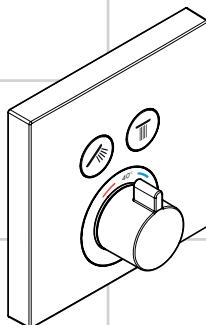

ShowerSelect
15763000



Sikkerhetshenvisninger

- △ Bruk hansker under montasjen for å unngå klem- og kuttskader.
- △ Produktet skal kun brukes for bade-, hygiene- og kroppshygiene.
- △ Barn og voksne med fysiske og psykiske og/eller sensoriske handicap skal ikke bruke dusjsystemet uten oppsyn. Personer som er påvirket av alkohol eller narkotika skal ikke bruke dusjsystemet.
- △ Store trykkdifferanser mellom kaldt- og varmtvannstilkoblinger skal utlignes.

Montagehenvisninger

- Før montasjen skal produktet sjekkes for transportskader. Etter monteringen aksepteres ikke noen transport- eller overflateskader.
- Ledningene og armaturen skal monteres, spyles og sjekkes iht. de gyldige normer.
- Gjeldende retningslinjer for rørleggerarbeid i de enkelte land skal følges.
- Dersom termostaten eller blendebatteriet er stilt inn på maksimal varmtvannstemperatur, kan det oppstå skåldeskader via den hydrauliske åpningen på stengeventilen. Hansgrohe anbefaler derfor innretningen "Safety Function".

Tekniske data

Driftstrykk	maks. 1 MPa
Anbefalt driftstrykk:	0,1 - 0,5 MPa
Prøvetrykk	1,6 MPa
(1 MPa = 10 bar = 147 PSI)	
Varmtvannstemperatur	maks. 80 °C
Anbefalt temperatur for varmt vann	65 °C
Termisk desinfisering:	maks. 70 °C / 4 min

- Egensikker mot tilbakeflyt
- Produktet er utelukkende designet for drikkevann!

Symbolbeskrivelse



Ikke bruk silikon som inneholder eddiksyre!



Justering (se side 66)

Etter avsluttet montering skal termostatens utløpstemperatur kontrolleres. Det er nødvendig med korrektur når temperaturen målt ved uttaksstedet avviker fra temperaturen som er innstilt på termostaten.

max. $\approx 42^{\circ}\text{C}$ Safety Function (se side 66)

Takket være egenskapen "Safety Function" kan det forhåndsinnstilles en ønsket maks. temperatur, f.eks. 42 °C.



Vedlikehold (se side 68)

- Termostaten er utstyrt med returløpsperre. Funksjonen til returløpsperren skal iht. DIN EN 1717 og i samsvar med de nasjonale og lokale forskrifter sjekkes regelmessig (DIN 1988 en gang i året).
- For å holde regulerings-enheten bevegelig, skal termostaten stilles fra tid til annen på helt varmt og helt kaldt.

Mål (se side 70)



Gjennomstrømningsdiagram (se side 70)

Fri gjennomstrømning ved 0,3 MPa:

- ① Utgang 1
- ② Utgang 2



Betjening (se side 71)

Ved første igangkjøring og etter ut-/innkobling av vannforsyningen kan det for en kort stund komme ut minimalt med vann.



Serviceledere (se side 72)

Fargekode

- 000 = krom
- 400 = hvit/krom
- 450 = hvit
- 600 = svart/krom
- 610 = svart



Prøvemerket (se side 72)



Rengjøring (se vedlagt brosjyre)

Feil	Årsak	Feilrettelse
Lite vann	<ul style="list-style-type: none"> - Forsyningstrykk er ikke tilstrekkelig - Smussfangersil til reguleringseheten skitten. - Dusjens silpakning er skitten 	<ul style="list-style-type: none"> - Ledningstrykk sjekkes - Smussfangersil før termostaten og på reguleringseheten rengjøres - Silpakning mellom dusj og slangen rengjøres
Krysstrømning, varmt vann presses ved lukket armatur inn i kaldvannsledning eller omvendt	- Returløpstopper skitten / defekt	- Returløpstopper rengjøres, byttes hvis nødvendig
Utløpstemperatur samsvarer ikke med innstilt temperatur	<ul style="list-style-type: none"> - Termostat ble ikke justert - For lav varmtvannstemperatur 	<ul style="list-style-type: none"> - Termostat justeres - Varmtvannstemperatur økes til mellom 42 °C og 65 °C
Temperaturregulering er ikke mulig	<ul style="list-style-type: none"> - reguleringsehet forkalket - Ved nyinstallasjon: basiselement feilaktig tilkoblet (riktig: kaldt høyre, varmt venstre) eller bygd inn 180° forvrent 	<ul style="list-style-type: none"> - reguleringsehet byttes - Funksjonsblokk bygges inn 180° forvrent
Trykknapp til sikkerhetssperren uten funksjon	<ul style="list-style-type: none"> - Fjær defekt - Kalk på trykknapp 	- Fjær hhv. Trykknapp rengjøres og smøres lett inn, byttes hvis nødvendig
Ventil er ikke lett bevegelig	- Select Sperreventil DN9 skadet	- Bytte Select Sperreventil DN9
Dusj eller utløp drypper	- Select Sperreventil DN9 skadet	- Bytte Select Sperreventil DN9
Tasten lar seg ikke bruke eller er uten funksjon	- Sikringen på stengeventilen er ikke fjernet	- Fjern sikringen fra stengeventilen
Tasten klemmer, går tregt	- Pakningen mangler smørning	- Smør pakningen



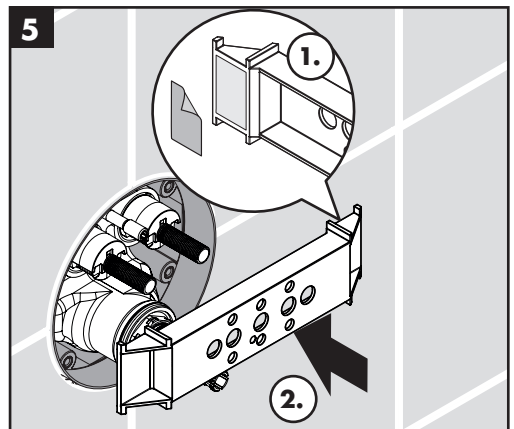
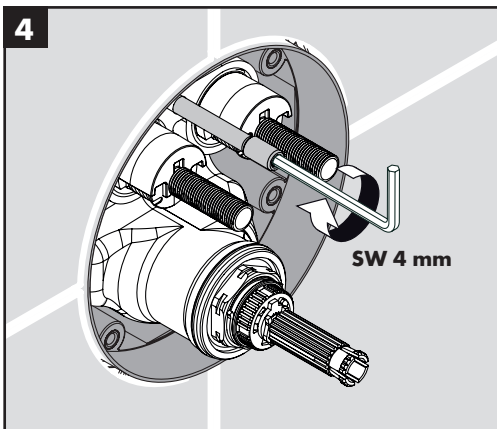
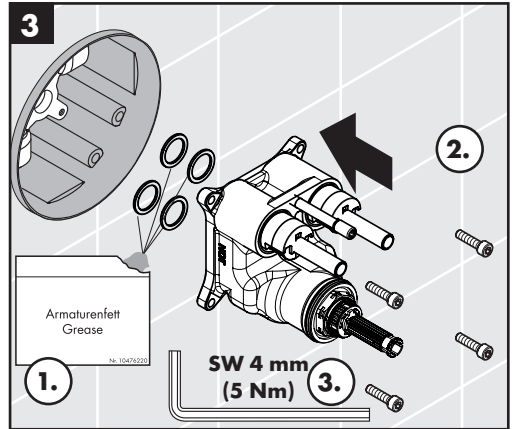
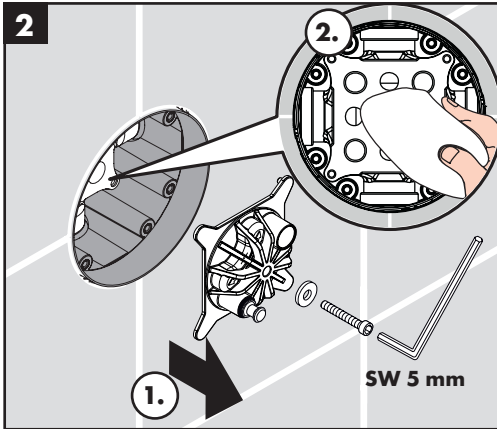
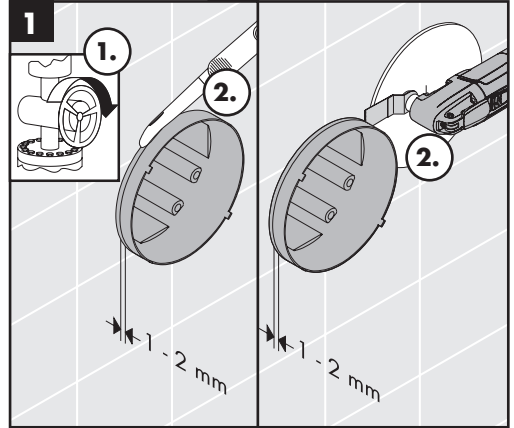
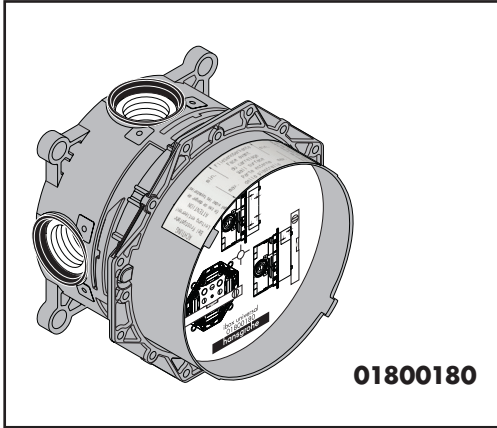

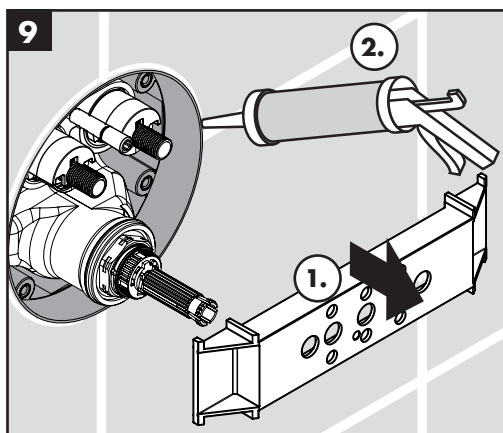
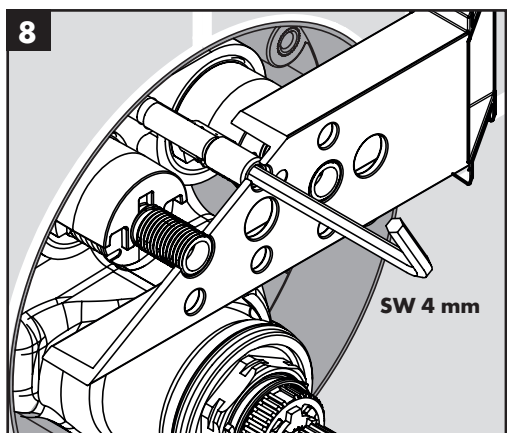
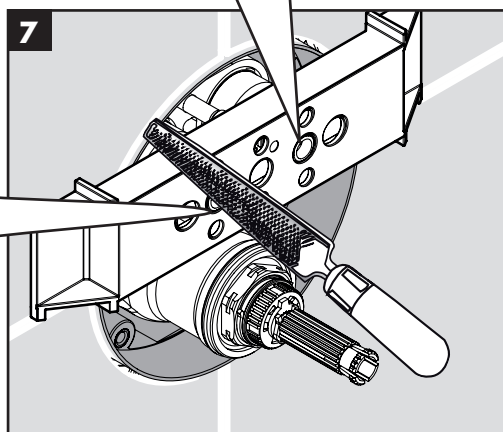
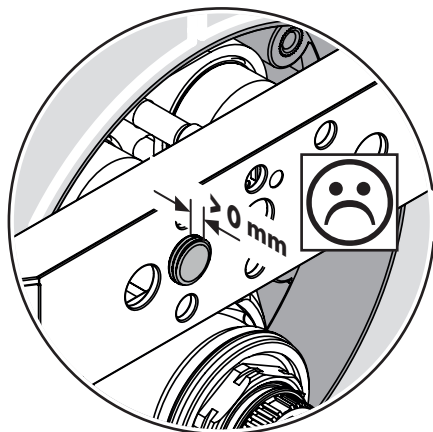
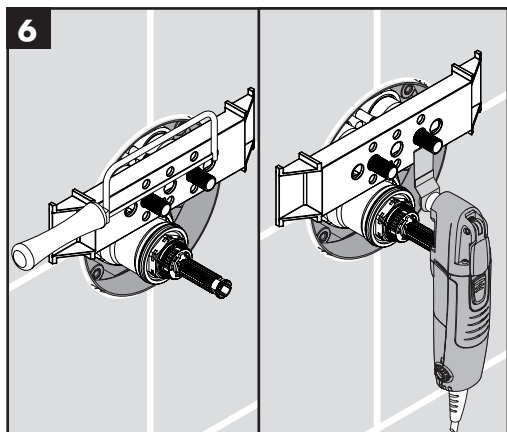

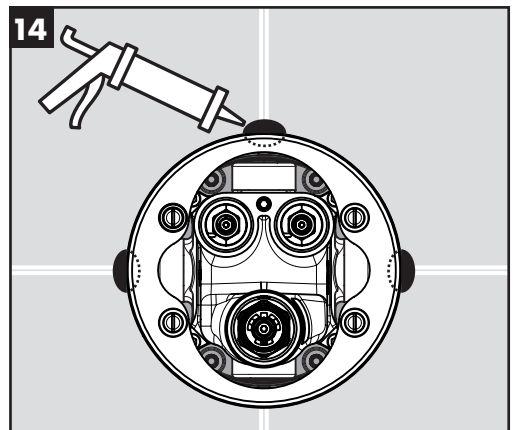
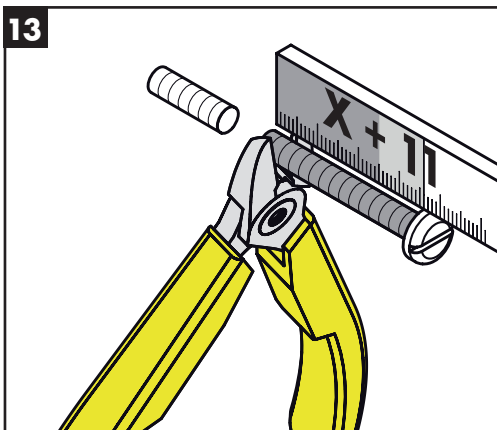
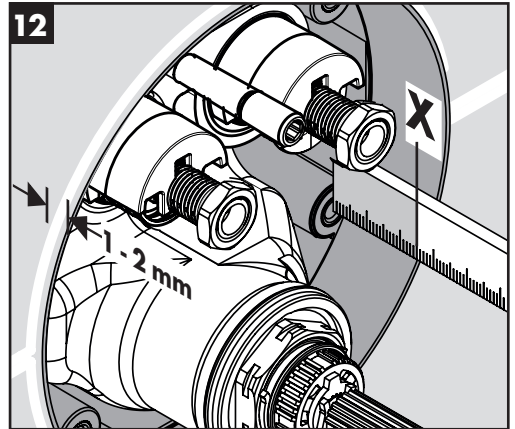
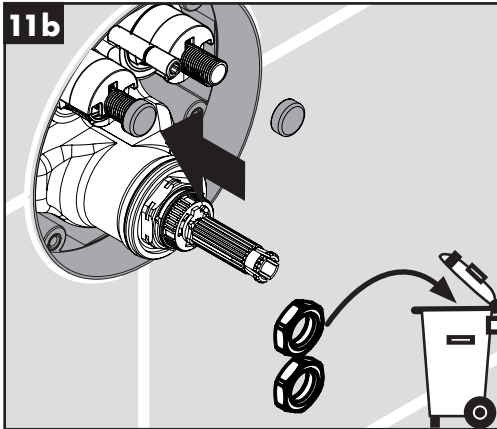
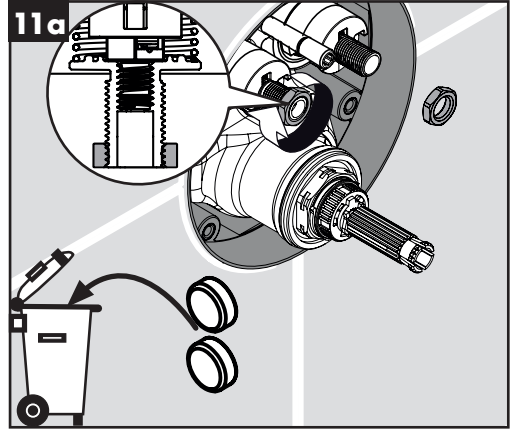
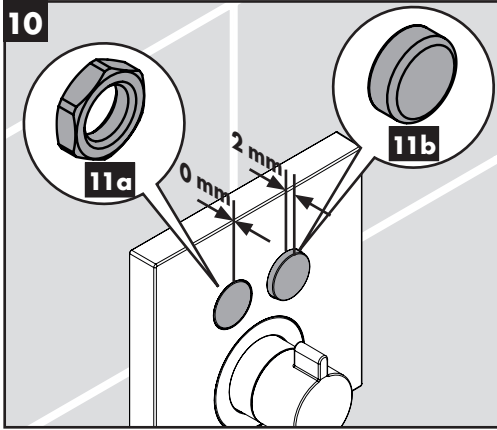

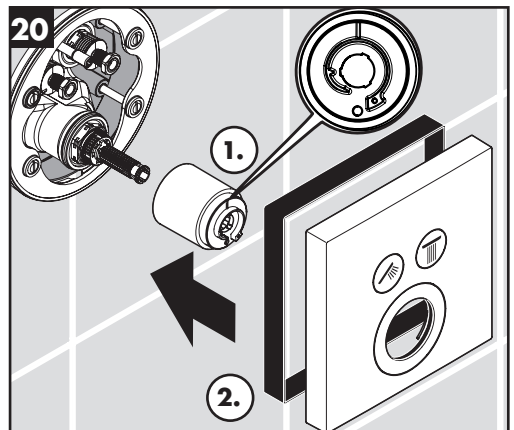
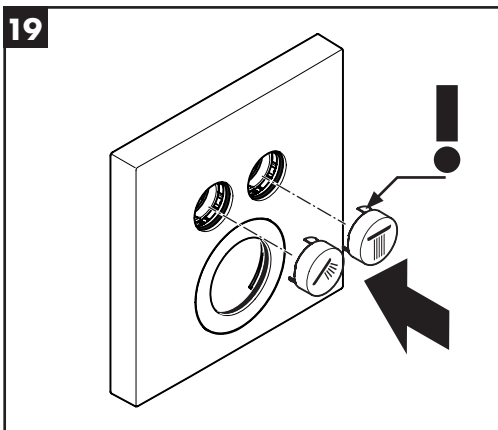
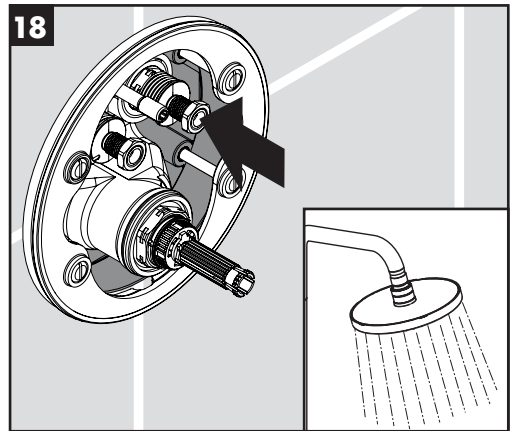
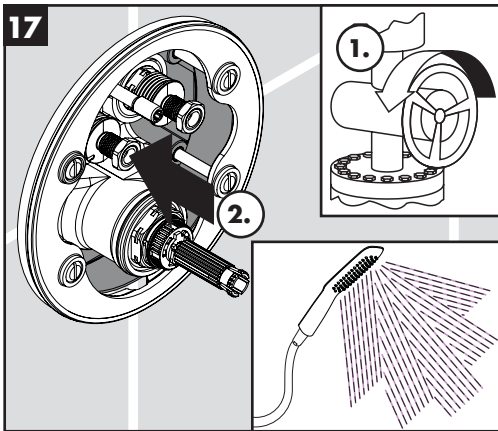
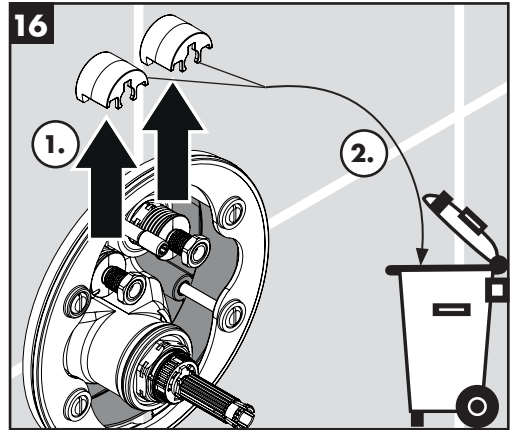
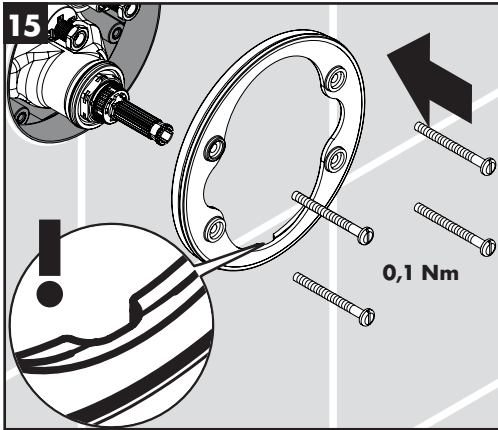

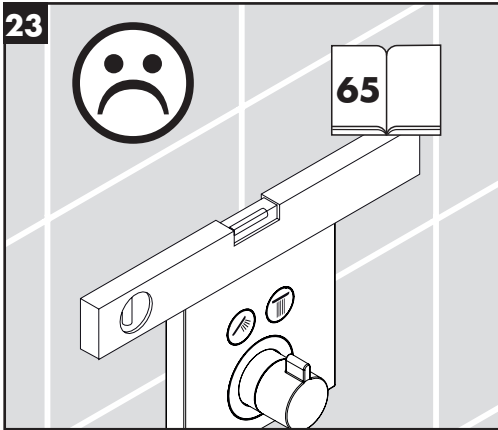
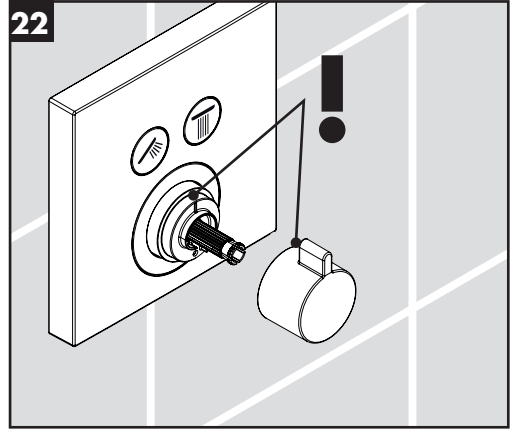
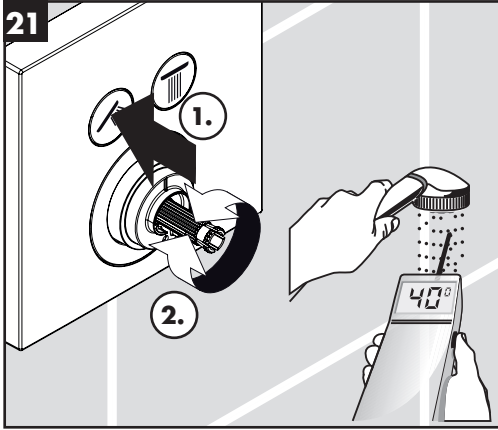

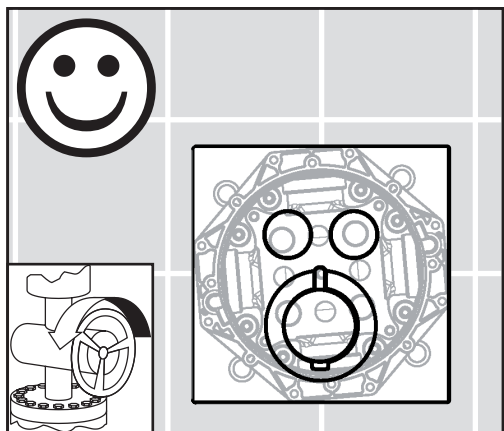
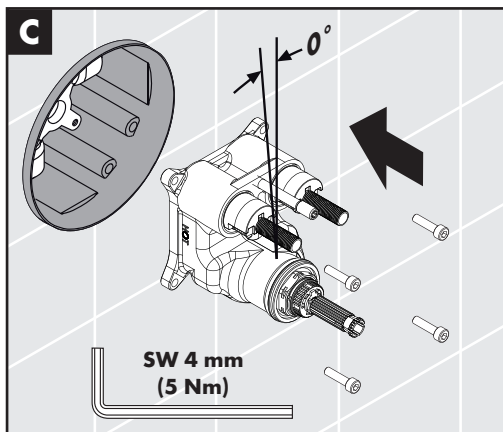
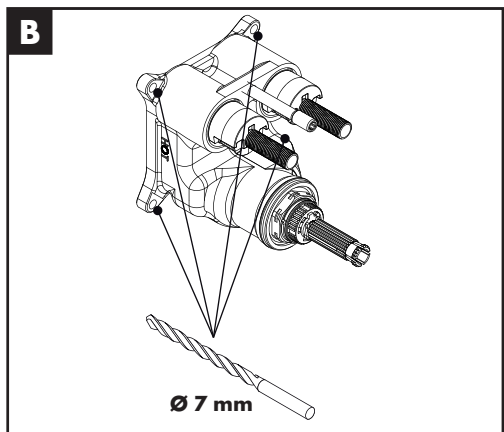
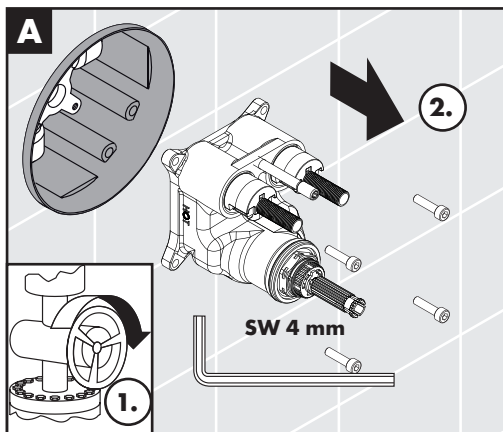
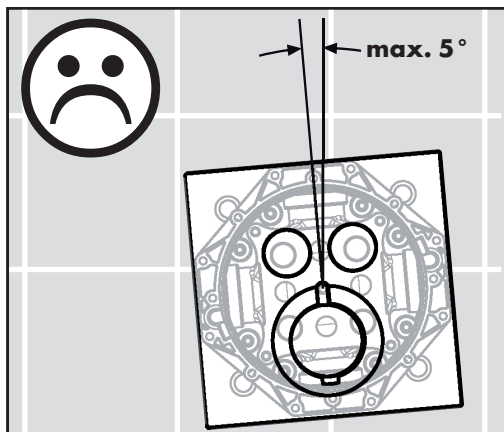

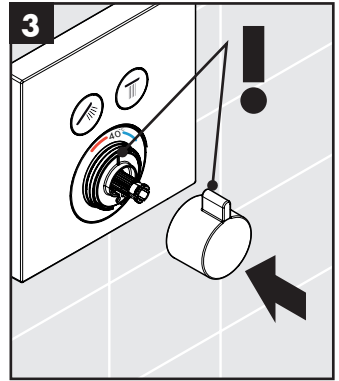
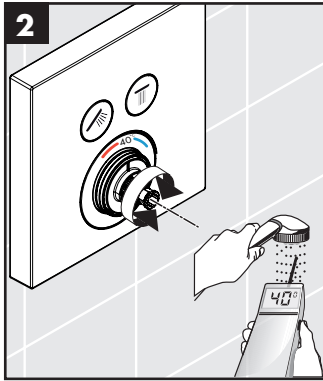
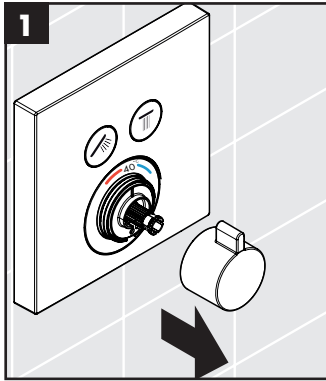

max.
≈ 42° C

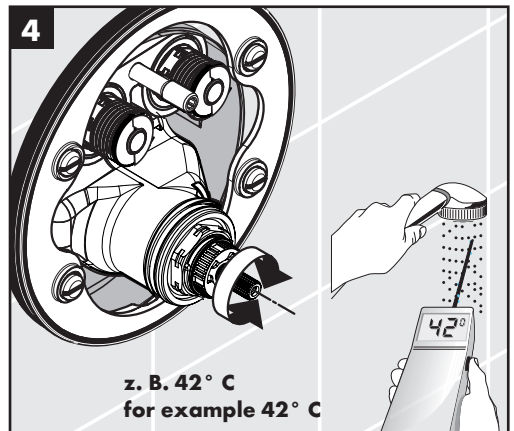
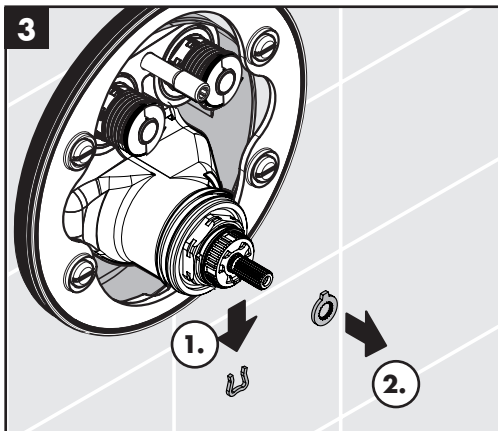
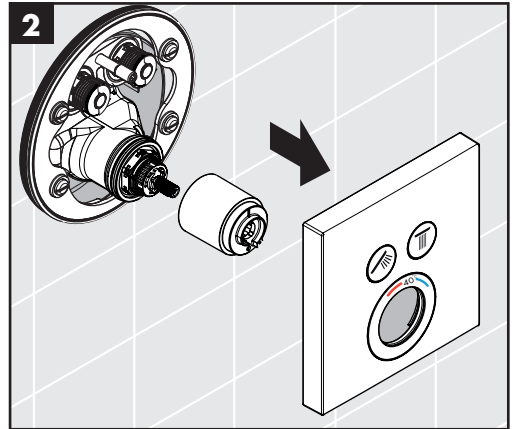
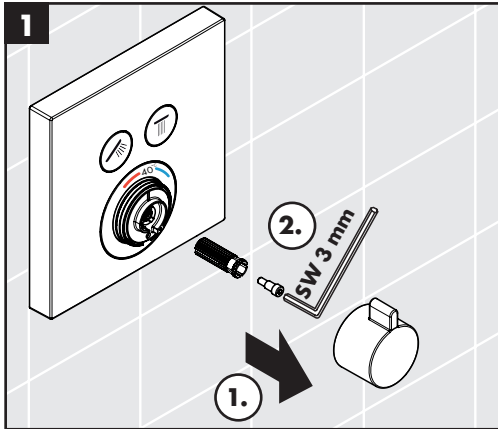

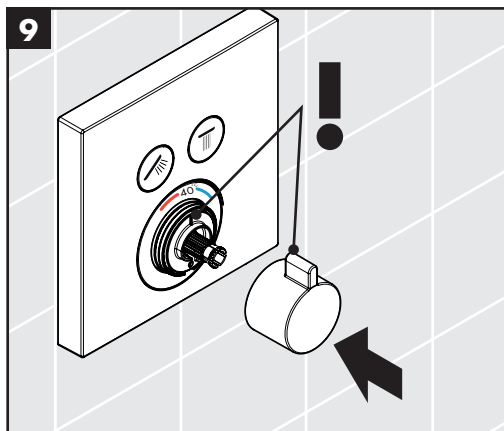
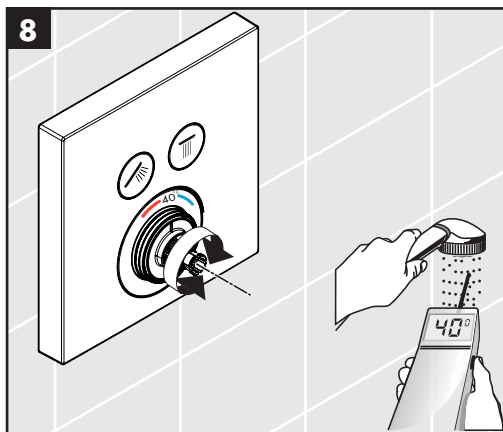
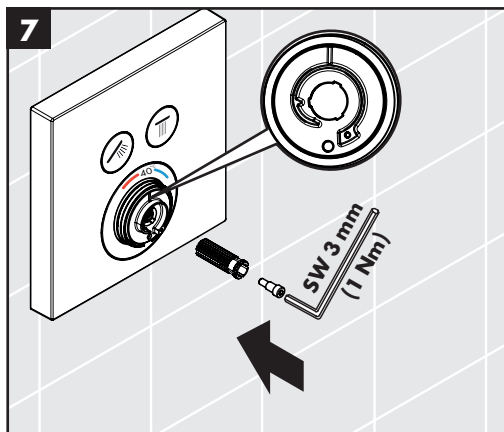
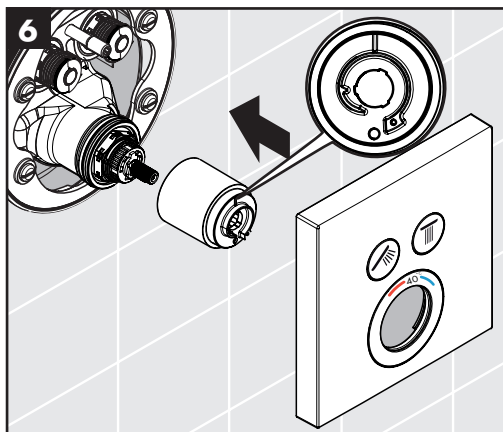
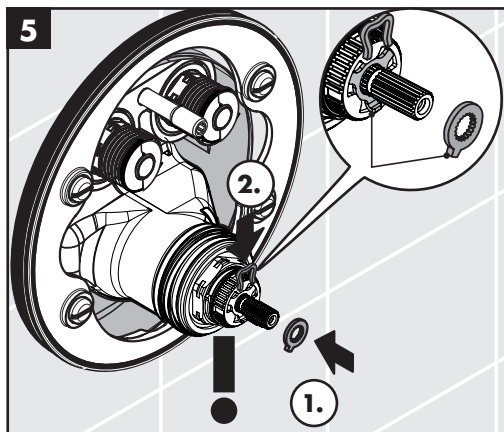

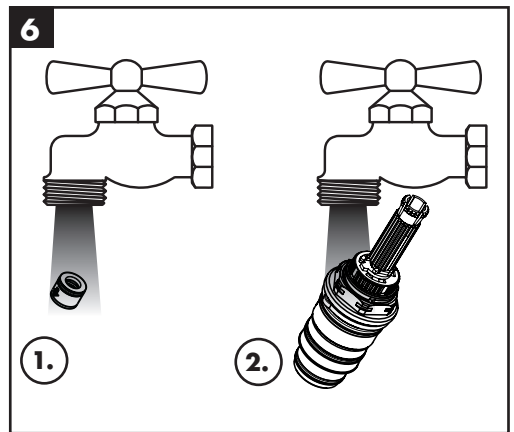
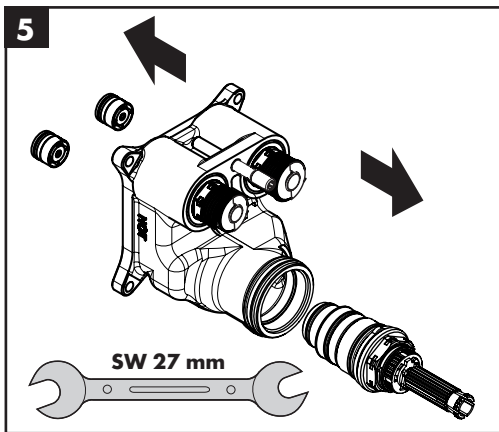
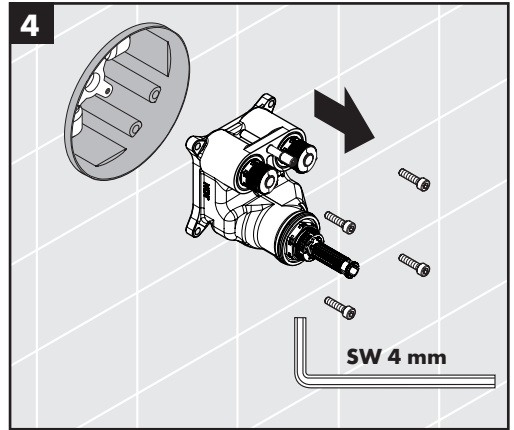
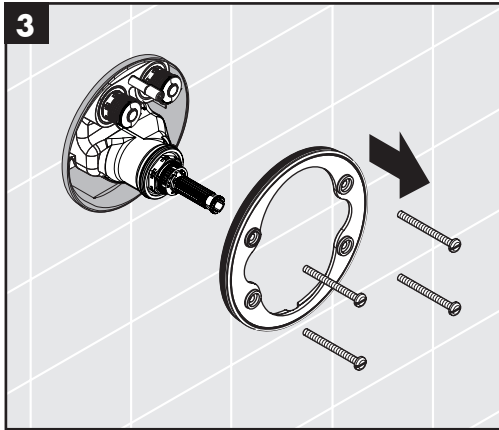
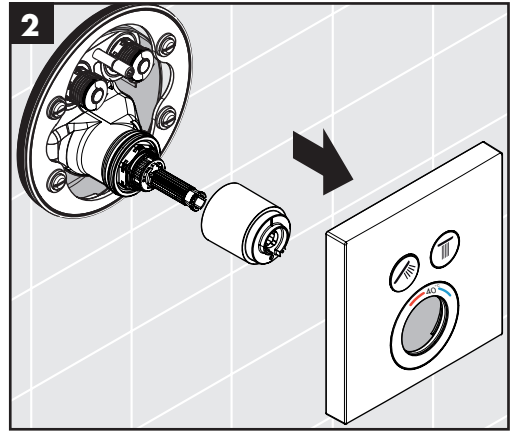
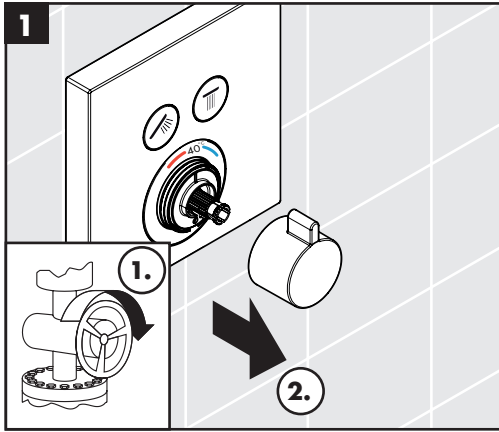

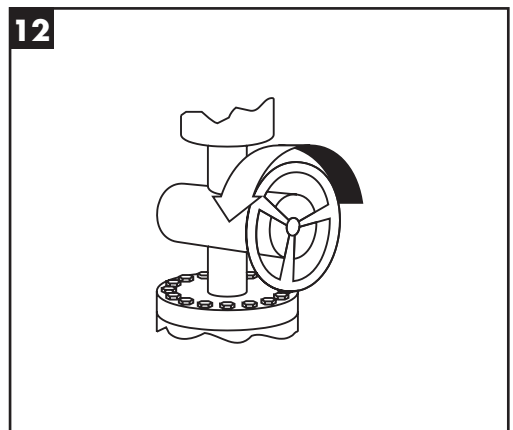
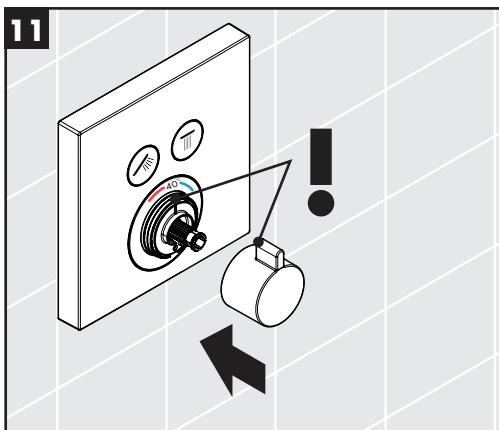
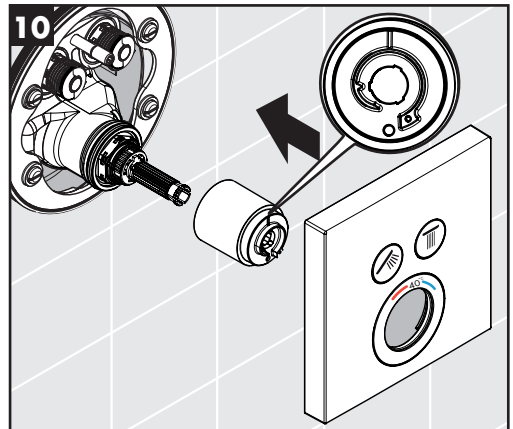
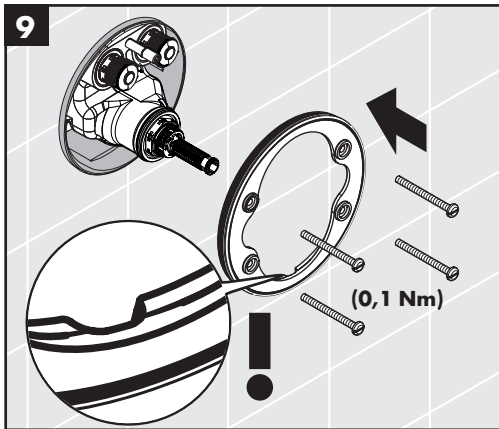
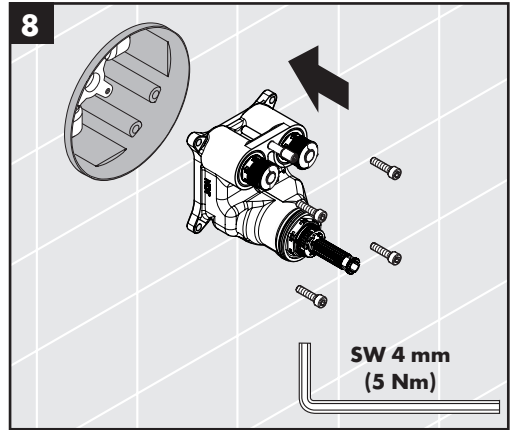
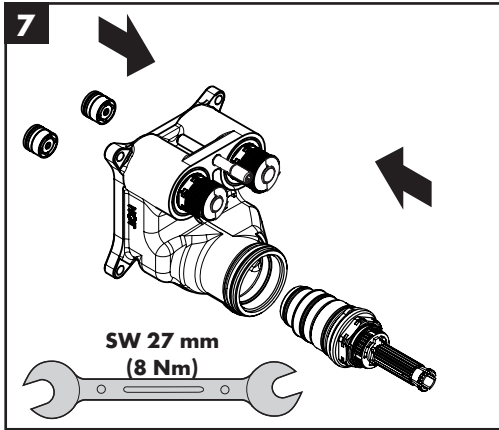



ShowerSelect

15738400 / 15738600

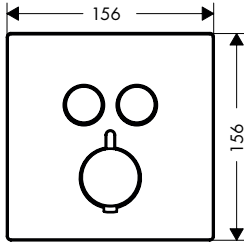
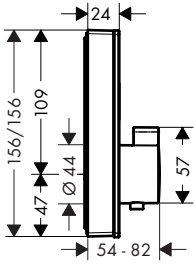

ShowerSelect S

15743000

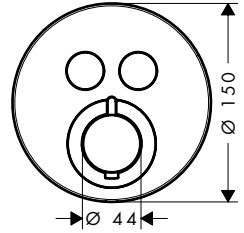
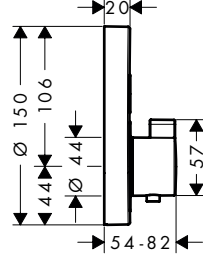

ShowerSelect

15743000

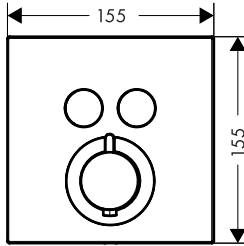
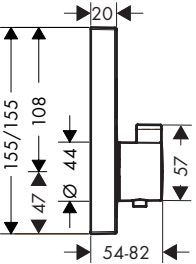

ShowerSelect

15738400 / 15738600 / 15763000

ShowerSelect S

15743000

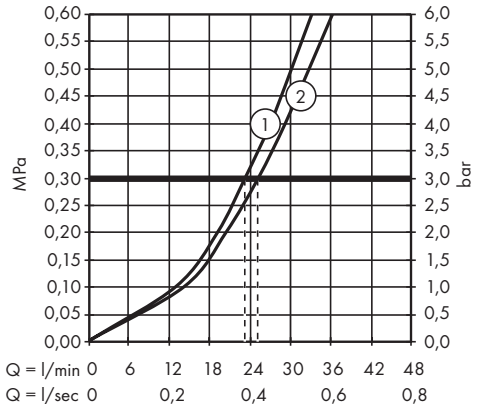
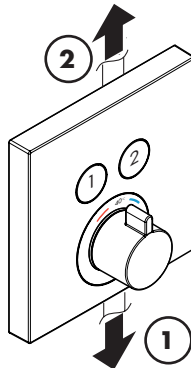

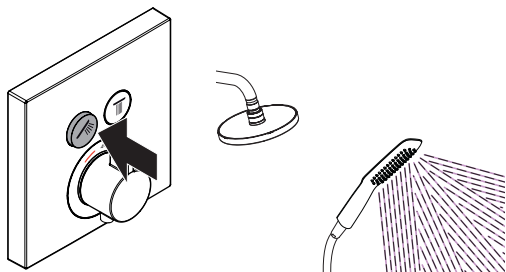

öffnen / ouvert / open / aperto / abierto / open / åbne /
 abrir / otworzyć / otevřít / otvorit / 开 / открыть / nyitás /
 avaaaminen / öppna / atidaryti / Отваранье / açmak /
 deschide / ανοικτό / odpreti / avage / atvērt / otvoriti /
 åpne / отварање / hare / فتح

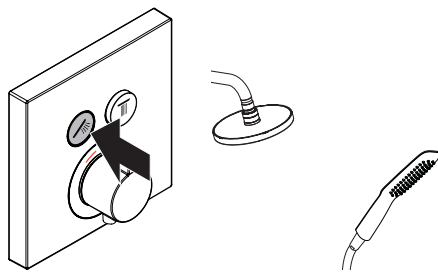

schließen / fermé / close / chiudere / cerrar / sluiten /
 lukke / fechar / zamknąć / zavřít / uzavriť / 关 /
 закрыть / bezárás / sulkeminen / stänga / uždaryti /
 Zatvaranje / karatmak / închide / κλειστό / zapreti /
 sulgege / aizvērt / zatvori / lukke / затварање / mbylle /
 إغلاق

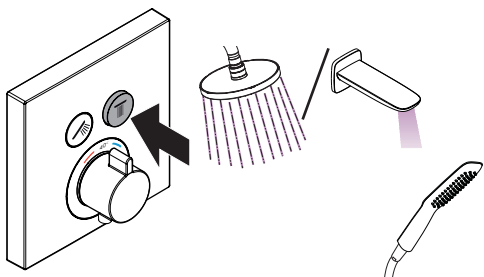

öffnen / ouvert / open / aperto / abierto / open / åbne /
 abrir / otworzyć / otevřít / otvorit / 开 / открыть / nyitás /
 avaaaminen / öppna / atidaryti / Отваранье / açmak /
 deschide / ανοικτό / odpreti / avage / atvērt / otvoriti /
 åpne / отварање / hare / فتح

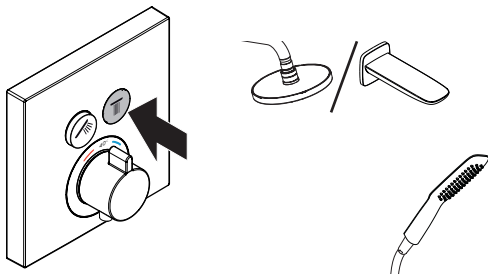

schließen / fermé / close / chiudere / cerrar / sluiten /
 lukke / fechar / zamknąć / zavřít / uzavriť / 关 /
 закрыть / bezárás / sulkeminen / stänga / uždaryti /
 Zatvaranje / karatmak / închide / κλειστό / zapreti /
 sulgege / aizvērt / zatvori / lukke / затварање / mbylle /
 إغلاق

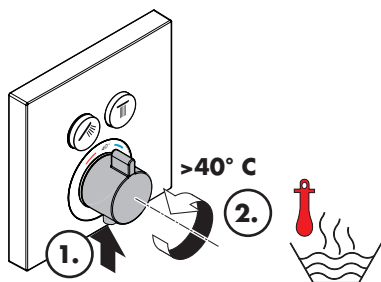

warm / chaud / hot / caldo / caliente / warm / varmt /
 quente / ciepła / teplá / teplá / 热 / горячая / meleg /
 lämmin / varmt / karštas / Vruća voda / sıcak / cald /
 ζεστό / toplo / kuum / karsts / topla / varm / тепло /
 i ngrohtë / ساخن

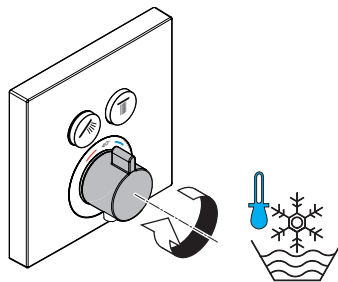

kalt / froid / cold / freddo / frío / koud / koldt / fria /
 zimna / studená / studená / 冷 / холодная / hideg /
 kylmä / kallt / šaltas / Hladno / soğuk / reze / κρύο /
 mrzlo / külm / auksts / hladno / kaldt / студено /
 i ftohtë / بارد

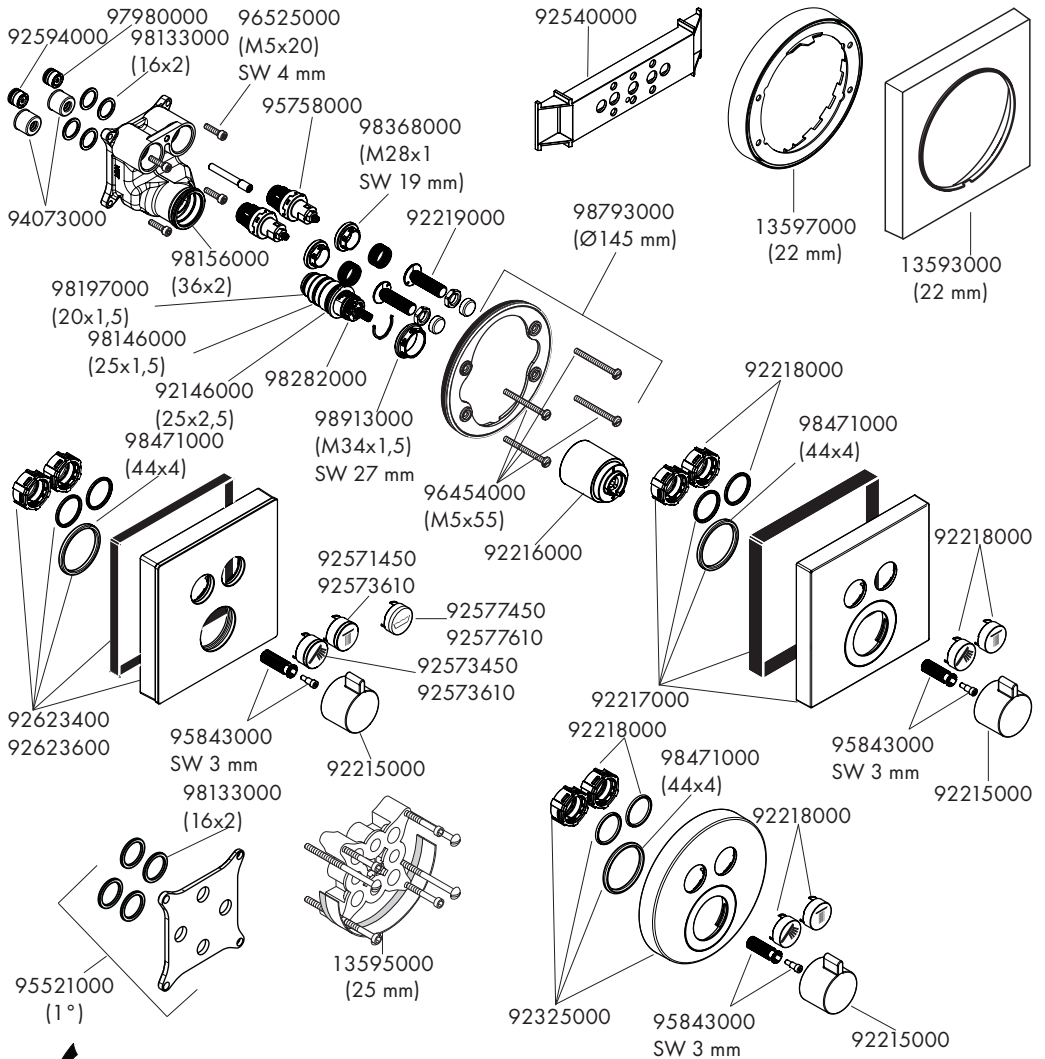

	PA-IX	DVGW	SVGW	ACS	WRAS	ETA	NF
15738400				X	X	ETA 1.43/20477	
15738600							
15743000	PA-IX 28414/IIBB			X	X	ETA 1.43/20477	
15763000	PA-IX 28414/IIBB			X	X	ETA 1.43/20477	X

