

Wilo-Yonos PICO-Z



de Einbau- und Betriebsanleitung
en Installation and operating instructions
fr Notice de montage et de mise en service
nl Inbouw- en bedieningsvoorschriften
es Instrucciones de instalación y funcionamiento
it Istruzioni di montaggio, uso e manutenzione
pt Manual de Instalação e funcionamento
tr Montaj ve kullanma kılavuzu
el Οδηγίες εγκατάστασης και λειτουργίας
sv Monterings- och skötselavsnisning
no Monterings- og driftsveiledning
fi Asennus- ja käyttöohje
da Monterings- og driftsvejledning
hu Beépítési és üzemeltetési utasítás

pl Instrukcja montażu i obsługi
cs Návod k montáži a obsluze
ru Инструкция по монтажу и эксплуатации
et Paigaldus- ja kasutusjuhend
lv Uzstādīšanas un ekspluatācijas instrukcija
lt Montavimo ir naudojimo instrukcija
sk Návod na montáž a obsluhu
sl Navodila za vgradnjo in obratovanje
hr Upute za ugradnju i uporabu
sr Uputstvo za ugradnju i upotrebu
ro Instrucțiuni de montaj și exploatare
bg Инструкция за монтаж и експлоатация
uk Інструкція з монтажу та експлуатації



**KΙΝΔΥΝΟΣ**

Θανάσιμος κίνδυνος για άτομα με ιατρικά εμφυτεύματα λόγω των μόνιμων μαγνητών που είναι ενσωματωμένοι στην αντλία.

**Απαγορεύεται η απόρριψη στα οικιακά απορρίμματα!**

Λεπτομέρειες θα βρείτε στις λεπτομερείς Οδηγίες χειρισμού στη διεύθυνση του εξωφύλλου.

SV

Denna kortare anvisning är en installationshjälp, referensdokumentet är den fullständiga driftsanvisningen som går att hitta under qr.wilo.com/336.

Högeffektiva cirkulationspumpar ur serien Yonos PICO-Z är uteslutande till för pumpning av tappvatten i cirkulationssystem för tappvatten i industri och byggnadstekniska installationer.

Installation/demontering måste utföras av kvalificerad personal. Använd endast godkända Wilo tillbehör.

Personalen måste vara informerad om lokala olycksförebyggande föreskrifter och ha läst och förstått monterings- och skötselansvisningen.

Produkten får endast användas av personal som informerats om hela anläggningens funktion.

Elektriska arbeten måste utföras av en behörig elektriker: riktlinjer, standarder och bestämmelser som gäller i landet samt riktlinjer från det lokala elförsörjningsbolaget som rör anslutning till det lokala elnätet måste följas.



Utrustningen får användas av barn från 8 år samt av personer med begränsad fysisk, sensorisk eller mental förmåga. Detta gäller även personer som saknar erfarenhet av denna utrustning eller inte vet hur den fungerar. I sådana fall ska handhavandet ske under uppsikt eller efter att personen ha fått instruktioner om hur utrustningen används säkert samt fått faror förknippade med osäker användning förklarade för sig. Barn får inte leka med utrustningen. Rengöring eller användarunderhåll får inte utföras av barn eller utan övervakning.

Använd aldrig pumpen med framkantsstyrning.

Vid skador på anslutningsledningen eller andra elektriska komponenter ska pumpen omedelbart tas ur drift.

Symbolförklaring



FARA

Livsfara på grund av elektrisk spänning!



FARA

Risk för personskador eller materiella skador till följd av felaktig användning!



FARA

Risk för brännskador på grund av heta ytor och/eller medier!



FARA

Livsfara för personer med medicinska implantat på grund av permanentmagneter monterade i pumpen.



Får inte slängas i vanligt hushållsavfall!

Detaljer finns i den fullständiga driftsanvisningen under länken på titelsidan.



NO

Denne hurtigveiledning er en installasjonsveiledning, referansedokumentet er den detaljerte driftsveiledningen som er tilgjengelig på qr.wilo.com/336.

Høyeffektivitets sirkelpumper i serien Stratos PICO-Z tjener utelukkende til transport av drikkevann i drikkevannsirkulasjonssystemene i industri og byggteknikk.

Installasjon/demontering må utføres av fagfolk. Bruk kun autorisert Wilo tilbehør.

Personellet må ha fått opplæring i de gjeldende lokale forskriftene for helse, miljø og sikkerhet, og ha lest og forstått monterings- og driftsveiledningen.

Betjening må utføres av personer som har fått opplæring i funksjonsmåten til hele anlegget.

Arbeid på det elektriske anlegget må utføres av en elektriker: Nasjonale retningslinjene, standarder og forskrifter, samt spesifikasjonene fra det lokale energiforsyningsverket for tilkobling til det lokale strømnettet må overholdes.

Dette apparatet kan brukes av barn fra 8 år og av personer med reduserte fysiske, sensoriske eller mentale evner eller manglende erfaring og kunnskap, hvis de er under oppsikt eller er blitt undervist om sikker bruk av apparatet og forstår farene forbundet med det. Barn skal ikke leke med apparatet. Rengjøring og brukervedlikehold skal ikke gjennomføres av barn uten tilsyn.

Pumpen må aldri brukes med fasevinkelkontroll.

Ved skader på tilkoblingsledningen eller andre elektriske kompo-



nenter må pumpen stanses umiddelbart.

Symbolforklaring



FARE

Livsfare i forbindelse med elektrisk spenning!



FARE

Fare for personskader eller materielle skader ved feil bruk!



FARE

Fare for forbrenninger pga. varme overflater og/eller varme medier!



FARE

Livsfare for personer med medisinske implantater på grunn av permanentmagneter innebygd i pumpen.



Det er forbudt å kaste produktet i husholdningsavfallet!

Mer informasjon er tilgjengelig i den detaljerte driftsveiledningen på adressen på tittelbladet.

FI

Tämä pikaohje on tarkoitettu asennuksen avuksi. Viitedokumenttina on täydellinen käyttöohje, joka löytyy osoitteesta qr.wilo.com/336.

High efficiency -kiertopumput mallisarjassa Yonos PICO-Z on ai-noastaan tarkoitettu käyttöveden pumppaamiseen käyttöveden kiertojärjestelmissä teollisuudessa ja rakenneustekniikassa.

Asennuksen/purkamisen saavat suorittaa vain ammattilaiset. Käytä vain hyväksytyjä lisävarusteita Wilo.



Henkilöstön on tunnettava paikalliset määräykset onnettomuuksien ehkäisemiseksi ja heidän on luettava ja ymmärrettävä asennus- ja käyttöohje.

Käyttöhenkilöstön on tunnettava koko järjestelmän käyttötavat.

Sähkötoita saavat suorittaa sähköalan ammattilaiset: kansallisia direktiivejä, normeja ja määräyksiä sekä paikallisen sähköyhtiön määräyksiä on noudatettava liitettäessä laite paikalliseen sähköverkkoon.

Tätä laitetta voivat käyttää yli 8-vuotiaat lapset sekä henkilöt, joiden fyysiset, sensoriset tai henkiset kyvyt ovat rajoittuneet tai joiden tiedoissa ja kokemuksissa on puutteita, jos heitä valvotaan tai jos heitä on opastettu käyttämään laitetta turvallisesti ja he ymmärtävät siihen liittyvät vaarat. Lapset eivät saa leikkiä laitteella. Lapset eivät saa puhdistaa tai huoltaa laitetta ilman valvontaa.

Pumppua ei koskaan saa käyttää vaihekulmamuutoksella.

Jos liitäntäjohdossa tai muissa sähkökomponenteissa on vauriota, poista pumppu välittömästi käytöstä.

Symbolien selitykset



VAARA

Sähköjännitteen aiheuttama hengenvaara!



VAARA

Virheellisen käytön aiheuttama loukkaantumisaava tai esinevahinkojen vaara!



VAARA

Kuumien pintojen ja/tai kuumien aineiden aiheuttama vaara!

**VAARA**

Pumpussa olevien pysyvien magneettien aiheuttama hengenvaara henkilöille, joilla on lääketieteellisiä implantteja.

**Hävittäminen talousjätteen joukossa on kielletty!**

Saat tarkat tiedot täydellisestä käyttöohjeesta, joka on otsikkosivulla olevassa osoitteessa.

DA

Denne korte vejledning er en installationshjælp, reference-dokumentet er den fulde betjeningsvejledning, som findes på adressen qr.wilo.com/336.

Højeffektive cirkulationspumper i serien Yonos PICO-Z er udelukkende beregnet til pumpning af drikkevand i drikkevandscirkulationssystemer inden for industri og bygningsteknik.

Installation/afmontering skal udføres af en fagmand. Anvend udelukkende autoriseret Wilo tilbehør.

Personalet skal være instrueret i de lokalt gældende arbejdsmiljøforskrifter og skal have læst og forstået monterings- og driftsvejledningen.

Betjening skal udføres af personer, som har modtaget undervisning i hele anlæggets funktionsmåde.

Elarbejdet skal udføres af en sagkyndig elektriker. Nationalt gældende retningslinjer, standarder og forskrifter samt det lokale energiforsyningssselskabs bestemmelser vedrørende tilslutning til det lokale strømnet skal overholdes.



Dette apparat kan anvendes af børn fra 8 år og derover og uden af personer med nedsatte fysiske, sensoriske og psykiske evner eller mangel på erfaring og viden, såfremt disse personer er under opsyn eller er instrueret i, hvordan apparatet skal anvendes sikkert, og de forstår de farer, der måtte være forbundet med brugen af apparatet. Børn må ikke lege med apparatet. Rengøring og vedligeholdelse må ikke udføres af børn uden opsyn.

Brug aldrig pumpen med fasestyring.

I tilfælde af beskadigelser på tilslutningsledningen eller andre elektriske komponenter skal pumpen omgående standses.

Symbolforklaring



FARE

Livsfare som følge af elektrisk spænding!



FARE

Risiko for personskader eller materielle skader ved fejlanvendelse!



FARE

Risiko for forbrændinger som følge af meget varme overflader og/eller varme medier!



FARE

Livsfare for personer med medicinske implantater som følge af den permanentmagnet, der er indbygget i pumpen.



Forbud mod sammenblanding med husholdningsaffald!

Yderligere oplysninger findes i den fulde betjeningsvejledning på adressen på forsiden.

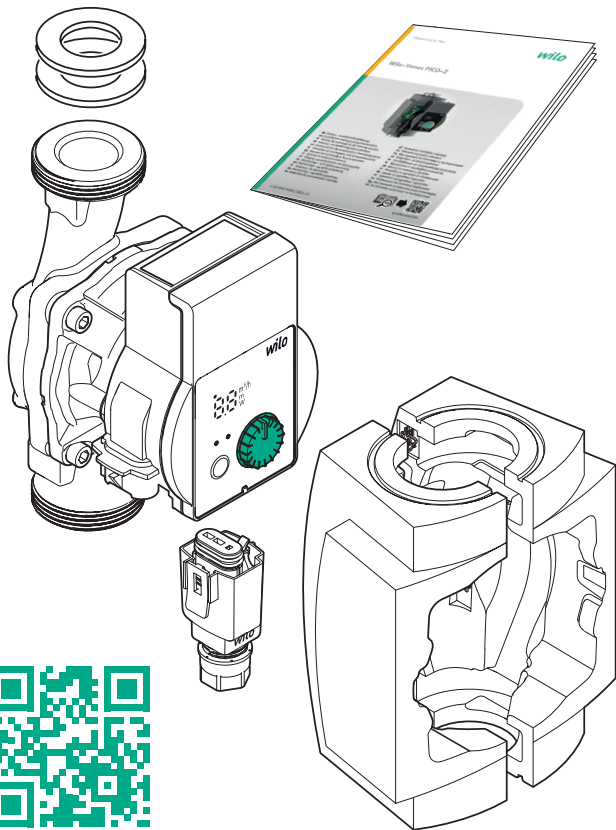

qr.wilo.com/336

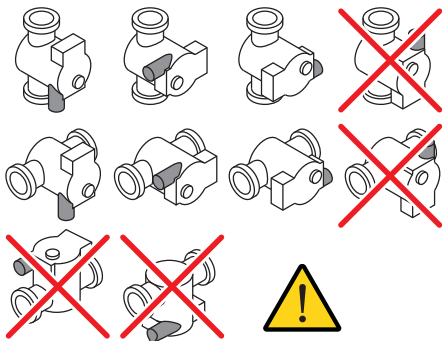
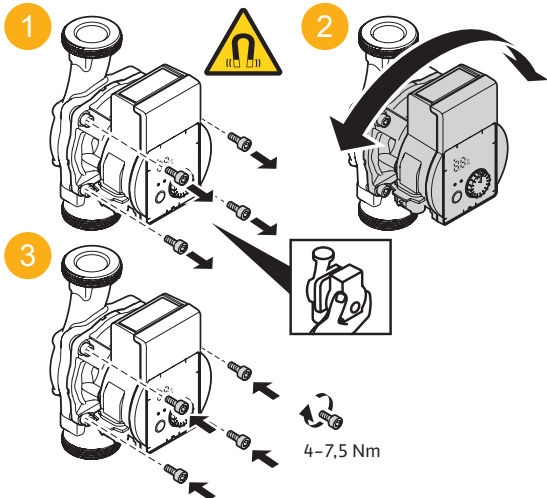



	$+2^{\circ}\text{C} \leq T \leq +95^{\circ}\text{C}$ $\varnothing P \leq 10 \text{ bar}$
	$\varnothing p_{\text{in}} (95^{\circ}\text{C}) \geq 0,3 \text{ bar}$

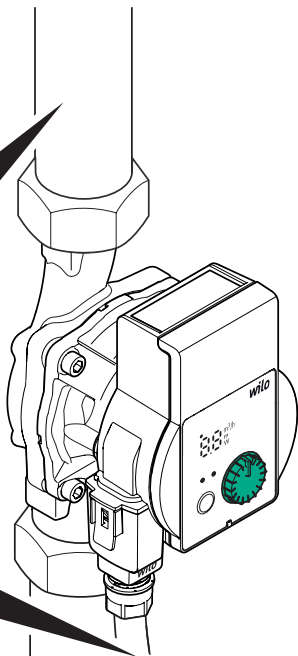

	$-10^{\circ}\text{C} \leq T \leq +40^{\circ}\text{C}$
--	---

	$1 \sim 230 \text{ V} \pm 10 \%$, $50/60 \text{ Hz}$
--	--

ON/OFF	$\leq 100/24 \text{ h}$ $\leq 20/\text{h} - 1 \text{ min}$
--------	---



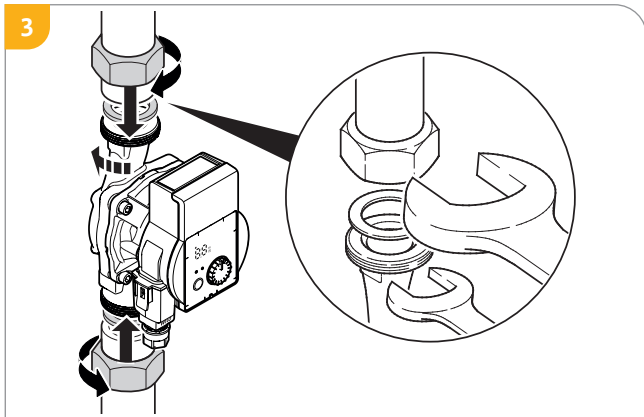
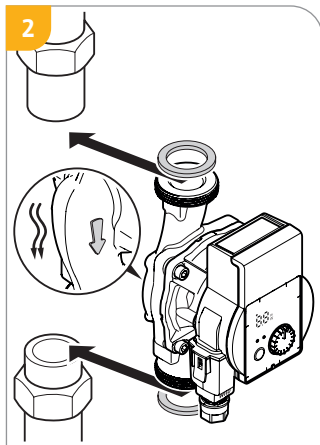
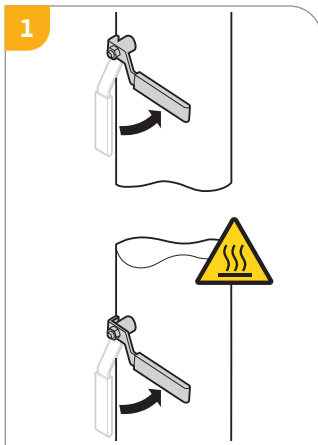



4

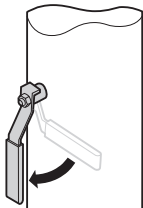
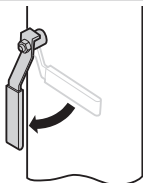

5

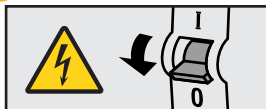

— — max 10 A

≥H05VV-F3G1.5

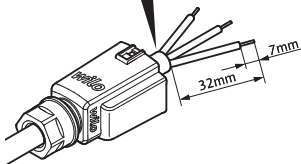

6

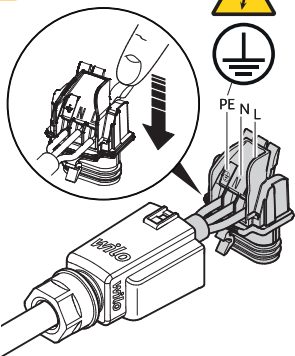

7

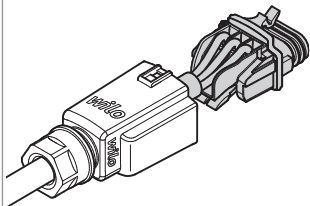



8

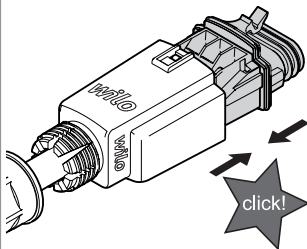

9

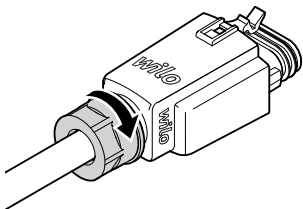

10

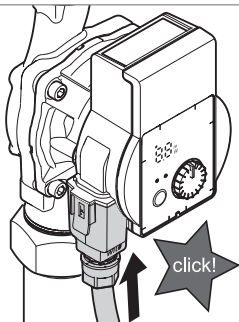

11

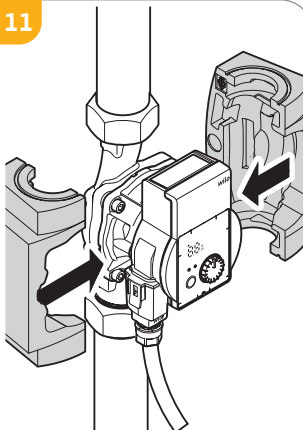

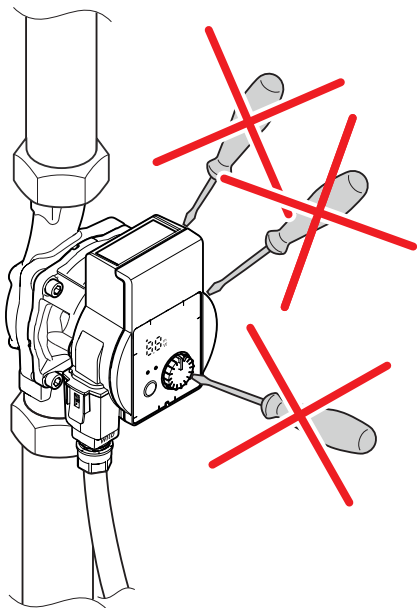
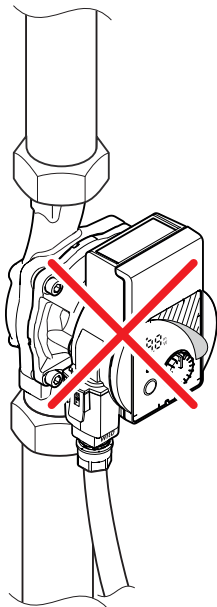

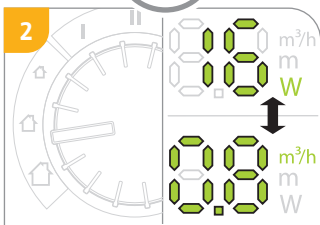
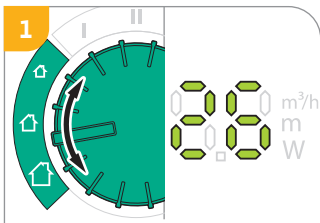
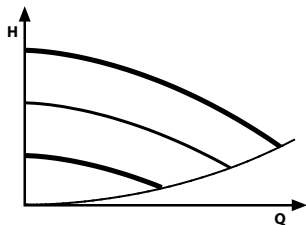
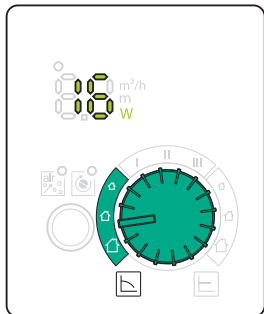

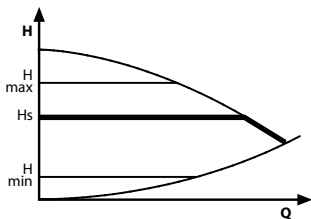
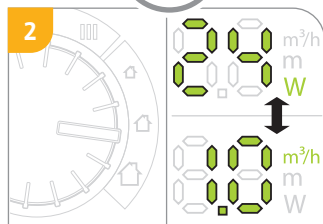
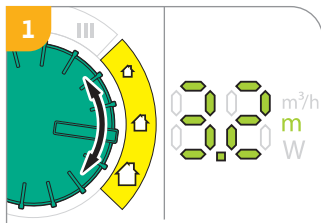
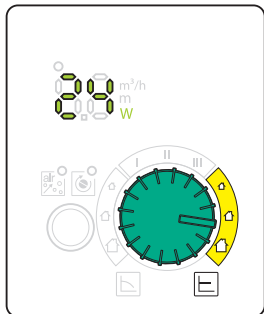

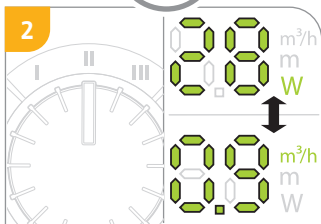
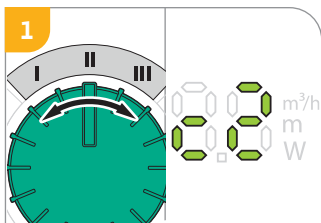
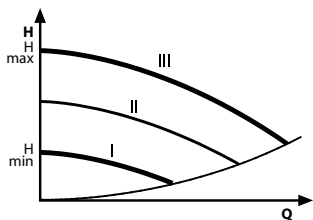
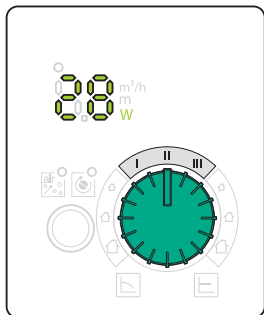

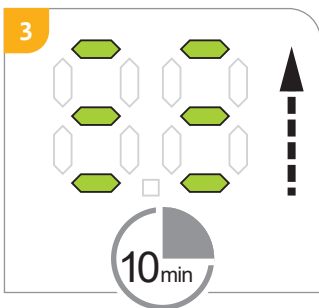
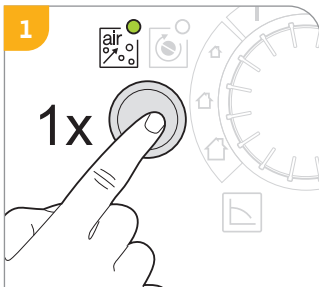
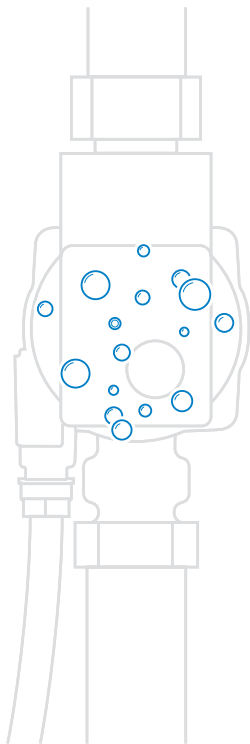

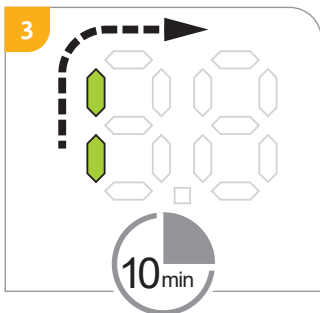
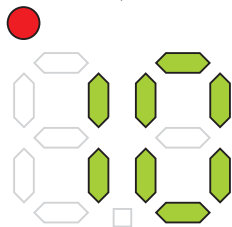
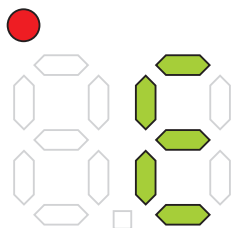



E

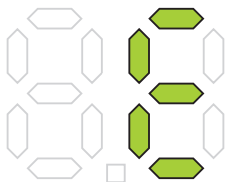

1

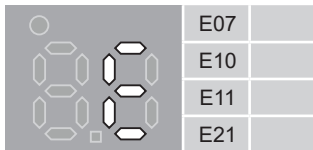
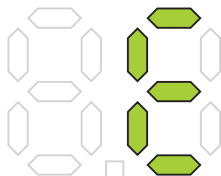

2

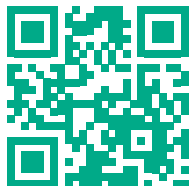
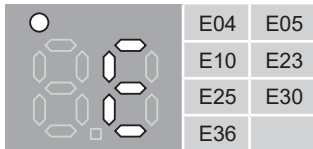
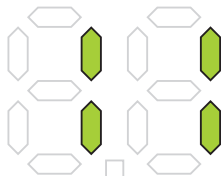
qr.wilo.com/336



DECLARATION OF CONFORMITY KONFORMITÄTSERKLÄRUNG

We, the manufacturer, declare under our sole responsibility that these glandless circulating pump types of the series,
Als Hersteller erklären wir unter unserer alleinigen Verantwortung, dass die Nassläufer-Umwälzpumpen der Baureihen,

Yonos PICO -Z...

(The serial number is marked on the product site plate)
(Die Seriennummer ist auf dem Typenschild des Produktes angegeben)

in their delivered state comply with the following relevant directives and with the relevant national legislation:
in der gelieferten Ausführung folgenden einschlägigen Bestimmungen entsprechen 'und entsprechender nationaler Gesetzgebung:

_ 2014/35/EU - LOW VOLTAGE / NIEDERSpannungsRICHTLINIE

_ 2014/30/EU - ELECTROMAGNETIC COMPATIBILITY / ELEKTROMAGNETISCHE VERTRÄGLICHKEIT - RICHTLINIE

_ 2011/65/EU + 2015/863 - RESTRICTION OF THE USE OF CERTAIN HAZARDOUS SUBSTANCES / BESCHRÄNKUNG DER VERWENDUNG BESTIMMTER GEFÄHRLICHER STOFFE-RICHTLINIE

comply also with the following relevant standards:
sowie auch den Bestimmungen zu folgenden harmonisierten europäischen Normen:

EN 60335-1:2012+A11:2014+A13:2017+A1:2019+A2:2019+A14:2019+A15:2021;
EN 60335-2-51:2003+A1:2008+A2:2012; EN IEC 61000-6-1:2019; EN IEC 61000-6-2:2019;
EN IEC 61000-6-3:2021; EN IEC 61000-6-4:2019; EN IEC 63000:2018;

Person authorized to compile the technical file is:
Bevollmächtigter für die Zusammenstellung der technischen Unterlagen ist:

Dortmund,

Digital unterschrieben
von Holger Herchenhein
Datum: 2022.09.15
16:12:35 +02'00'

H. HERCHENHEIN
Senior Vice President - Group Quality & Qualification

WILO SE
Group Quality
Wilopark 1
D-44263 Dortmund

wilo

Wilopark 1
D-44263 Dortmund



DA	<p>Vi, producenten, erklærer under vores eget ansvar, at disse kirtelfrie cirkulationspumpe typer i serien, (Serienummeret er markeret på produktpladen) i deres leverede tilstand overholder følgende relevante direktiver og den relevante nationale lovgivning:</p> <p>Yonos PICO -Z...</p> <p> 2014/35/EU - Lavspændings 2014/30/EU - Elektromagnetisk Kompatibilitet 2011/65/EU + 2015/863 - Begrænsning af anvendelsen af visse farlige stoffer</p> <p>også overholde følgende relevante standarder: EN 60335-1:2012+A11:2014+A13:2017+A1:2019+A2:2019+A14:2019+A15:2021; EN 60335-2-51:2003+A1:2008+A2:2012; EN IEC 61000-6-1:2019; EN IEC 61000-6-2:2019; EN IEC 61000-6-3:2021; EN IEC 61000-6-4:2019; EN IEC 63000:2018;</p> <p style="text-align: right;">WILO SE Group Quality Wilopark 1</p> <p style="text-align: right;"><i>Person, der er autoriseret til at udarbejde den tekniske fil, er: D-44263 Dortmund</i></p>
ET	<p>Mele, tootja, kuulutame ainuiskulisel vastutusel, et need seeria näarmeteta tsirkulatsioonipumbad, (Seeria number on märgitud toote saidi plaadile) oma tarmitud olekus järgmisi asjakohaseid direktiive ja asjakohaseid siseriiklikke õigusakte:</p> <p>Yonos PICO -Z...</p> <p> 2014/35/EU - Madalpingeseadmed 2014/30/EU - Elektromagnetilist Ühilduvust 2011/65/EU + 2015/863 - teatavate ohtlike ainete kasutamise piiramise kohta</p> <p>vastama ka järgmistele asjakohastele standarditele: EN 60335-1:2012+A11:2014+A13:2017+A1:2019+A2:2019+A14:2019+A15:2021; EN 60335-2-51:2003+A1:2008+A2:2012; EN IEC 61000-6-1:2019; EN IEC 61000-6-2:2019; EN IEC 61000-6-3:2021; EN IEC 61000-6-4:2019; EN IEC 63000:2018;</p> <p style="text-align: right;">WILO SE Group Quality Wilopark 1</p> <p style="text-align: right;"><i>Tehnilise toimiku koostamiseks on volitatud isik: D-44263 Dortmund</i></p>
FI	<p>Me valmistajata vakuutamme yksinomaissella vastuullamme, että nämä sarjan tiivistettömät kiertovesipumput, (Sarjanumero on merkitty tuotekohdaisella kilpaleen) toimituksessa tilassa noudattavat seuraavia asiaankuuluvia direktiivejä ja asiaa koskevaa kansallista lainsäädäntöä:</p> <p>Yonos PICO -Z...</p> <p> 2014/35/EU - Matala Jännite 2014/30/EU - Sähkömagneettinen Yhteensopivuus 2011/65/EU + 2015/863 - tiettyjen vaarallisten aineiden käytön rajoittamisesta</p> <p>noudattamaan myös seuraavia asiaankuuluvia standardeja: EN 60335-1:2012+A11:2014+A13:2017+A1:2019+A2:2019+A14:2019+A15:2021; EN 60335-2-51:2003+A1:2008+A2:2012; EN IEC 61000-6-1:2019; EN IEC 61000-6-2:2019; EN IEC 61000-6-3:2021; EN IEC 61000-6-4:2019; EN IEC 63000:2018;</p> <p style="text-align: right;">WILO SE Group Quality Wilopark 1</p> <p style="text-align: right;"><i>Henkilö, jolla on valtuudet koosta tekninen tiedosto, on: D-44263 Dortmund</i></p>
IS	<p>Við framleiðandinn lýsum því yfir undir ábyrgð okkar einungis að þessar kirtillausu hringlagðar dælugerðir seríunnar, (Raðnúmerið er merkt á plötunni á vörudöðnum) í afhentu ástandi í samræmi við eftirfarandi víðeigandi tilskipanir og víðeigandi innlenda löggjöf:</p> <p>Yonos PICO -Z...</p> <p> 2014/35/EU - Lágspennu-tilskipun 2014/30/EU - Rafseguls-samhæfni-tilskipun 2011/65/EU + 2015/863 - Takmörkun á notkun tiltekinnna hættulegra efna</p> <p>uppfylla einnig eftirfarandi víðeigandi staðla: EN 60335-1:2012+A11:2014+A13:2017+A1:2019+A2:2019+A14:2019+A15:2021; EN 60335-2-51:2003+A1:2008+A2:2012; EN IEC 61000-6-1:2019; EN IEC 61000-6-2:2019; EN IEC 61000-6-3:2021; EN IEC 61000-6-4:2019; EN IEC 63000:2018;</p> <p style="text-align: right;">WILO SE Group Quality Wilopark 1</p> <p style="text-align: right;"><i>Sá sem hefur heimild til að taka saman tekniskrána er: D-44263 Dortmund</i></p>
LT	<p>Mes, kaip gamintojas, siūvo atsakomybės ribose deklaruojame, kad šios serijos šlapio rotatoriaus siurblių modeliai, (Serijos numeris pažymėtas ant produkto lentelės) taip kaip pristatyti, atitinka sekančias aktualias direktyvas ir nacionalines teisės normas bei reglamentas:</p> <p>Yonos PICO -Z...</p> <p> 2014/35/EU - Žema [tampa] 2014/30/EU - Elektromagnetinis Suderinamumas 2011/65/EU + 2015/863 - dėl tam tikrų pavojingų medžiagų naudojimo apribojimo</p> <p>taip pat atitinka sekančias aktualius standartus: EN 60335-1:2012+A11:2014+A13:2017+A1:2019+A2:2019+A14:2019+A15:2021; EN 60335-2-51:2003+A1:2008+A2:2012; EN IEC 61000-6-1:2019; EN IEC 61000-6-2:2019; EN IEC 61000-6-3:2021; EN IEC 61000-6-4:2019; EN IEC 63000:2018;</p> <p style="text-align: right;">WILO SE Group Quality Wilopark 1</p> <p style="text-align: right;"><i>Asmuo įgaliojtas sudaryti techninius dokumentus yra: D-44263 Dortmund</i></p>

LV Deklarācijas oficiālais tulkojums	<p>Mēs, ražotājs, ar pilnu atbildību paziņojam, ka šie slapjā rotora cirkulācijas sūkņu tipi, (Sērājis numurs ir norādīts uz iestrādājuma plāksnītes)</p> <p>piegādātāja valstī atbilst šādām attiecīgām direktīvām un attiecīgām valsts tiesību aktiem:</p> <p> 2014/35/EU - Zemsprieguma 2014/30/EU - Elektromagnētiskās Saderības 2011/65/EU + 2015/863 - par dažu bīstamu vielu izmantošanas ierobežošanu 2011/65/UE</p> <p>atbilst arī sekojošiem attiecīgām standartiem:</p> <p>EN 60335-1:2012+A11:2014+A13:2017+A1:2019+A2:2019+A14:2019+A15:2021; EN 60335-2-51:2003+A1:2008+A2:2012; EN IEC 61000-6-1:2019; EN IEC 61000-6-2:2019; EN IEC 61000-6-3:2021; EN IEC 61000-6-4:2019; EN IEC 63000:2018;</p> <p style="text-align: right;">WILO SE Group Quality Wolpark 1</p> <p style="text-align: right;">Yonos PICO -Z...</p> <p style="text-align: right;">Persona pilnvarota sastādīt tehnisko dokumentāciju: D-44263 Dortmund</p>
NL Officiële vertaling van de verklaring	<p>Wij, de fabrikant, verklaren onder onze eigen verantwoordelijkheid dat deze natoloper-circulatiepompen van de serie, (Het serienummer staat vermeld op het naamplaatje van het product)</p> <p>in de leverde versie voldoen aan de volgende relevante bepalingen en aan de overeenkomstige nationale wetgeving:</p> <p> 2014/35/EU - Laagspannings 2014/30/EU - Elektromagnetische Compatibiliteit 2011/65/EU + 2015/863 - betreffende beperking van het gebruik van bepaalde gevaarlijke stoffen</p> <p>voldoen ook aan de volgende relevante normen:</p> <p>EN 60335-1:2012+A11:2014+A13:2017+A1:2019+A2:2019+A14:2019+A15:2021; EN 60335-2-51:2003+A1:2008+A2:2012; EN IEC 61000-6-1:2019; EN IEC 61000-6-2:2019; EN IEC 61000-6-3:2021; EN IEC 61000-6-4:2019; EN IEC 63000:2018;</p> <p style="text-align: right;">WILO SE Group Quality Wolpark 1</p> <p style="text-align: right;">Yonos PICO -Z...</p> <p style="text-align: right;">De persoon die bevoegd is om het technische bestand samen te stellen is: D-44263 Dortmund</p>
NO Offisiell oversettelse av erklæring	<p>Vi som produsent erklærer herved vårt ansvar at våtåper sirkulasjonspumper under type serie, (serienummeret er markert på pumpeplakett)</p> <p>I levert tilstand vil produkt overholde følgende direktiver og relevant nasjonal lovgivning</p> <p> 2014/35/EU - Lavspenningsdirektiv 2014/30/EU - EMV-Elektromagnetisk kompatibilitet 2011/65/EU + 2015/863 - Begrensning av bruk av visse farlige stoffer</p> <p>Oppfølger også relevante standarder</p> <p>EN 60335-1:2012+A11:2014+A13:2017+A1:2019+A2:2019+A14:2019+A15:2021; EN 60335-2-51:2003+A1:2008+A2:2012; EN IEC 61000-6-1:2019; EN IEC 61000-6-2:2019; EN IEC 61000-6-3:2021; EN IEC 61000-6-4:2019; EN IEC 63000:2018;</p> <p style="text-align: right;">WILO SE Group Quality Wolpark 1</p> <p style="text-align: right;">Yonos PICO -Z...</p> <p style="text-align: right;">Vedkommendesom er autorisert til å sammenstille teknisk fil er: D-44263 Dortmund</p>
SV Officiell översättning av försäkran	<p>Vi, tillverkaren, försäkrar under eget ansvar att de vätlöpande cirkulationspumparna i serien (Serienumret finns utmärkt på produktens dataarkyt)</p> <p>i det utförande de levererades överrenstämmer med följande relevanta direktiv och relevant nationell lagstiftning</p> <p> 2014/35/EU - Lågsäpännings 2014/30/EU - Elektromagnetisk Kompatibilitet 2011/65/EU + 2015/863 - begränsning av användning av vissa farliga ämnen</p> <p>överrenstämmer också med följande relevanta standarder:</p> <p>EN 60335-1:2012+A11:2014+A13:2017+A1:2019+A2:2019+A14:2019+A15:2021; EN 60335-2-51:2003+A1:2008+A2:2012; EN IEC 61000-6-1:2019; EN IEC 61000-6-2:2019; EN IEC 61000-6-3:2021; EN IEC 61000-6-4:2019; EN IEC 63000:2018;</p> <p style="text-align: right;">WILO SE Group Quality Wolpark 1</p> <p style="text-align: right;">Yonos PICO -Z...</p> <p style="text-align: right;">Person behörigt att sammanställa denna tekniska fil är: D-44263 Dortmund</p>
GA Eadar-theangachadh oifigeil den Ghairm	<p>Bidh sinn, an neach-déanadh, a foillseachadh fon uallach againn gu bheil na seòrsachan pumpa cuairteachaidh glandless seo den t-sreath, (Tha an àireamh sreathach air a chomharrachadh air clàr làrach an toraidh)</p> <p>anns an stàit ìbhricidh aca gèilleadh ris na stiùirdhean buntainneach a leanas agus ris an reachdas nàiseanta buntainneach:</p> <p> 2014/35/EU - Ìsealvoltais 2014/30/EU - Comhoirfùnach Leictreamaignèadach 2011/65/EU + 2015/863 - Srian ar an úsáid a bhaint as substaintean guaiseacha acu</p> <p>gèilleadh cuideachd ris na h-inbhean ìomchaidh a leanas:</p> <p>EN 60335-1:2012+A11:2014+A13:2017+A1:2019+A2:2019+A14:2019+A15:2021; EN 60335-2-51:2003+A1:2008+A2:2012; EN IEC 61000-6-1:2019; EN IEC 61000-6-2:2019; EN IEC 61000-6-3:2021; EN IEC 61000-6-4:2019; EN IEC 63000:2018;</p> <p style="text-align: right;">WILO SE Group Quality Wolpark 1</p> <p style="text-align: right;">Yonos PICO -Z...</p> <p style="text-align: right;">Is e an neach le ùghdarras an fàidhe teicneach a chur ri chèile: D-44263 Dortmund</p>



ДЕКЛАРАЦИЯ ИЗГОТОВИТЕЛЯ DECLARATION OF MANUFACTURER

Мы, изготовитель, заявляем под нашу
исключительную ответственность, что
циркуляционные насосы с мокрым ротором типов
We, the manufacturer, declare under our sole
responsability that these glandless circulating pump
types of the series,

Yonos PICO -Z...

(Серийный номер указан на заводской табличке изделия)
(The serial number is marked on the product site plate)

в поставленном исполнении соответствуют следующим техническим регламентам
in their delivered state comply with the following relevant directives and with the relevant national legislation:

_TP TC 010/2011 "О безопасности машин и оборудования" / TR CU 010/2011 "On the safety of machinery and equipment"

_TP TC 004/2011 "О безопасности низковольтного оборудования" / TR CU 004/2011 "On safety of low-voltage equipment"

_TP TC 020/2011 "Электромагнитная совместимость технических средств" / TR CU 020/2011 "Electromagnetic compatibility of technical devices"

_TP EAЭС 037/2016 "Об ограничении применения опасных веществ в изделиях электротехники и радиоэлектроники" / TR EAEU 037/2016 "On restriction of the use of certain hazardous substances in electrical and electronic equipment"

соблюдая также следующие соответствующие стандарты:
comply also with the following relevant harmonised European standards:

**ГОСТ IEC 60335-1-2015; ГОСТ IEC 60335-2-51-2012; ГОСТ 30804.6.1-2013;
ГОСТ 30804.6.2-2013; ГОСТ 30804.6.3-2013; ГОСТ IEC 61000-6-4-2016;
ГОСТ EN 50581-2016;**

Лицо, уполномоченное составлять технический файл:
Person authorized to compile the technical file is:

Dortmund,

ppa. H. Herchenhein

Digital unterschrieben
von Holger Herchenhein

Datum: 2022.09.26
13:49:18 +02'00'

H. HERCHENHEIN
Senior Vice President - Group Quality & Qualification

WILO SE
Group Quality
Wilopark 1
D-44263 Dortmund

wilo

Wilopark 1
D-44263 Dortmund



ДЕКЛАРАЦИЯ ИЗГОТОВИТЕЛЯ DECLARATION OF MANUFACTURER

ПРИЛОЖЕНИЕ

I. Информация о дате изготовления

Дата изготовления указана на заводской табличке оборудования. Разъяснения по определению даты изготовления: Например: YYwWW = 22w30
YY = год изготовления w = символ «Неделя» WW = неделя изготовления

II. Сведения об обязательной сертификации.

Сертификат/декларация соответствия №
срок действия

№ ЕАЭС РУ С-ДЕ.БЛ08.В.01487/22

19.08.2022-18.08.2027

«IVANOVO-CERTIFICATE», Ivanovo, accreditation
certificate №RA.RU.11БЛ08 от 24.03.2016

III. Информация о производителе и официальных представительствах.

1. Информация об изготовителе

Изготовитель: WILO SE (ВИЛО СЕ)

Страна производства указана на заводской табличке оборудования.

2. Официальные представительства на территории ЕАЭС.

Россия:
ООО «ВИЛО РУС»,
109012, г. Москва, вн.тер.г. муниципальный
округ Таверской, ул Охотный Ряд, д. 2,
этаж/пол 10/Л1, кон/офис 3/2.10
Телефон +7 (496) 514-61-10
Факс + 7 (496) 514-61-11
E-mail: wilo@wilo.ru

Беларусь:
ИООУ «ВИЛО БЕЛ»,
220004, г. Минск, ул. Клары Цеткин, д.24, пом.
7-1
Телефон: (017) 396-34-46
E-mail: wilo@wilo.by

Казахстан:
ТОО «Wilo Central Asia», 040704,
Алматынская область, Илийский район,
поселок Байсерке, ул. Султана Бейбарса, дом
1
Телефон +7 (727) 312-40-10
Факс +7 (727) 312-40-00
E-mail: info@wilo.kz

IV Дополнительная информация к инструкции по монтажу и эксплуатации.

Срок хранения:

Новое оборудование может храниться как минимум в течение:

3 года

Оборудование должно быть тщательно очищено перед помещением на временное хранение. Оборудование следует хранить в чистом, сухом, защищенном от замерзания месте.

Техническое обслуживание:

Оборудование не требует обслуживания. Рекомендуется регулярная проверка каждые

50000 ч

Срок службы:

При правильном режиме эксплуатации, соблюдении всех указаний Инструкции по монтажу и эксплуатации и при своевременном выполнении планово-предупредительных ремонтов, срок службы оборудования

10 лет.* (*5 лет для WeN)

Уровень шума:

Уровень шума оборудования составляет не более

40 дБ(А)

В случае превышения указанного значения, информация указывается на наклейке оборудования или в инструкции по монтажу и эксплуатации.

Безопасная утилизация:

Благодаря правильной утилизации и надлежащему вторичному использованию данного изделия предотвращается нанесение ущерба окружающей среде и опасности для здоровья персонала. Правила утилизации требуют опорожнения и очистки, а также демонтажа оборудования.

Собрать смазочный материал. Выполнить сортировку деталей по материалам (металл, пластик, электроника).

1. Для утилизации данного изделия, а также его частей следует привлекать государственные или частные предприятия по утилизации.

2. Дополнительную информацию по надлежащей утилизации можно получить в муниципалитете, службе утилизации или в месте, где изделие было куплено.

Критерии предельного состояния:

Основным критерием предельного состояния изделия является отказ одной или нескольких составных частей, ремонт или замена которых не предусмотрены или является экономически нецелесообразным.

wilo

Wilopark 1
D-44263 Dortmund



ДЕКЛАРАЦІЯ ПРО ВІДПОВІДНІСТЬ DECLARATION OF CONFORMITY KONFORMITÄTSERKLÄRUNG

Ми, виробник, заявляємо під нашу виключну відповідальність, що ці безсальникові циркуляційні насоси, які виготовляються серійно, We, the manufacturer, declare under our sole responsibility that these glandless circulating pump types of the series,

Als Hersteller erklären wir unter unserer alleinigen Verantwortung, daß die Nassläufer-Umwälzpumpen der Baureihen,

Yonos PICO -Z...

(Серійний номер позначений на інформаційній табличці виробу.
The serial number is marked on the product site plate.
Die Seriennummer ist auf dem Typenschild des Produktes angegeben)

в поставленому виконанні відповідають наступним відповідним Технічним регламентам: in their delivered state comply with the following relevant directives and with the relevant national legislation: in der gelieferten Ausführung folgenden einschlägigen Bestimmungen entsprechen und entsprechender nationaler Gesetzgebung:

_ БЕЗПЕКИ НИЗЬКОВОЛЬТНОГО ЕЛЕКТРИЧНОГО ОБЛАДНАННЯ (ПОСТАНОВА 1067) / LOW-VOLTAGE ELECTRICAL EQUIPMENT (RESOLUTION 1067) / SICHERHEIT VON NIEDERSpannungs-ELEKTRISCHE AUSRÜSTUNGEN (BESCHLUß 1067)

_ ЕЛЕКТРОМАГНІТНОЇ СУМІСНОСТІ ОБЛАДНАННЯ (ПОСТАНОВА 1077) / ELECTROMAGNETIC COMPATIBILITY (RESOLUTION 1077) / ELEKTROMAGNETISCHE VERTRÄGLICHKEIT (BESCHLUß 1077)

_ ОБМЕЖЕННЯ ВИКОРИСТАННЯ ДЕЯКИХ НЕБЕЗПЕЧНИХ РЕЧОВИН (ПОСТАНОВА 139) / RESTRICTION OF THE USE OF CERTAIN HAZARDOUS SUBSTANCES (RESOLUTION 139) / BESCHRÄNKUNG DER VERWENDUNG BESTIMMTER GEFÄHRLICHER STOFFE (BESCHLUß 139)

також при дотриманні наступних відповідних стандартів: comply also with the following relevant standards: sowie auch den Bestimmungen zu folgenden Normen:

**ДСТУ EN 60335-1:2017; ДСТУ EN 60335-2-51:2015 зі змінами № 1:2015, 2:2015;
ДСТУ EN IEC 61000-6-1:2019; ДСТУ EN 61000-6-2:2018;
ДСТУ EN 61000-6-3:2018; ДСТУ IEC 61000-6-4:2019;
ДСТУ EN IEC 63000:2020;**

Особа, уповноважена скласти технічний файл:
Person authorized to compile the technical file is:
Bevollmächtigter für die Zusammenstellung der technischen Unterlagen ist:

Dortmund,

Digital unterschrieben
von Holger Herchenheim
Datum: 2022.09.15
16:12:09 +02'00'

H. HERCHENHEIN
Senior Vice President - Group Quality & Qualification

WILO SE
Group Quality
WiloPark 1
D-44263 Dortmund

wilo

WiloPark 1
D-44263 Dortmund

**DECLARATION OF CONFORMITY**

We, the manufacturer, declare under our sole responsibility that these glandless circulating pump types of the series,

Yonos PICO -Z...

(The serial number is marked on the product site plate)

in their delivered state comply with the following relevant directives and with the relevant national legislation:

_ **Electrical Equipment (Safety) Regulations (SI 2016 No. 1101) amended**

_ **Electromagnetic Compatibility (EMC) Regulations (SI 2016 No. 1091) amended**

_ **Restriction of the Use of Certain Hazardous Substances (RoHS) in Electrical and Electronic Equipment Regulations (SI 2012 No. 3032) amended**

comply also with the following relevant standards:

BS EN 60335-1:2012+A11:2014+A13:2017+A1:2019+A2:2019+A14:2019;
BS EN 60335-2-51:2003+A1:2008+A2:2012;
BS EN IEC 61000-6-1:2019; BS EN IEC 61000-6-2:2019;
BS EN IEC 61000-6-3:2021; BS EN IEC 61000-6-4:2019;
BS EN IEC 63000:2018;

Person who places the product on the market:

Dortmund,

Digital unterschrieben
 von Holger Herchenhein
 Datum: 2022.09.15
 16:13:12 +02'00'

H. HERCHENHEIN
 Senior Vice President - Group Quality & Qualification

Wilo (UK) Ltd
 2nd Avenue, Centrum 100
 Burton upon Trent - DE14 2WJ
 Staffordshire - United Kingdom

wilo

Wilopark 1
 D-44263 Dortmund



DECLARATION OF CONFORMITY

We, the manufacturer, declare under our sole responsibility that these glandless circulating pump types of the series,

Yonos PICO -Z...

(The serial number is marked on the product site plate)

in their delivered state comply with the following relevant directives and with the relevant national legislation:

_ ELECTRICAL EQUIPMENT SAFETY SCHEME (EESS)

_ RADIOCOMMUNICATIONS LABELLING (ELECTROMAGNETIC COMPATIBILITY) NOTICE 2017

comply also with the following relevant standards:

**AS/NZS 60335.1:2020; AS/NZS 60335.2.51:2020; AS/NZS 61000.6.1:2006 (R2016);
AS/NZS 61000.6.2:2006 (R2016); AS/NZS 61000.6.3:2021; AS 61000.6.4:2020;**

Person authorized to compile the technical file is:

Dortmund,

**Digital unterschrieben
von Holger
Herchenhein
Datum: 2022.10.17
09:32:03 +02'00'**

H. HERCHENHEIN
Senior Vice President - Group Quality & Qualification

WILO SE
Group Quality
Wilopark 1
D-44263 Dortmund

wilo

Wilopark 1
D-44263 Dortmund



wilo

GARANTİ BELGESİ

Bu belge 6502 sayılı Tüketicinin Korunması Hakkında Kanun ve Garanti Belgesi Yönetmeliği'ne uygun olarak düzenlenmiştir.

GARANTİ ŞARTLARI

1. Garanti süresi, malın teslim tarihinden itibaren başlar ve **2 yıldır**.
2. Malın bütün parçaları dahil olmak üzere tamamı garanti kapsamındadır.
3. Malın ayıplı olduğunun anlaşılması durumunda tüketici, 6502 sayılı Tüketicinin Korunması Hakkında Kanununun 11 inci maddesinde yer alan;
 - a- **Sözleşmeden dönme,**
 - b- **Satış bedelinden indirim isteme,**
 - c- **Ücretsiz onarılmasını isteme,**
 - d- **Satılanın ayıpsız bir misli ile değiştirilmesini isteme,** haklarından birini kullanabilir.
4. **Tüketicinin bu haklardan ücretsiz onarım hakkını** seçmesi durumunda satıcı; işçilik masrafı, değiştirilen parça bedeli ya da başka herhangi bir ad altında hiçbir ücret talep etmeksizin malın onarımını yapmak veya yaptırmakla yükümlüdür. Tüketici ücretsiz onarım hakkını üretici veya ithalatçıya karşı da kullanabilir. Satıcı, üretici ve ithalatçı tüketicinin bu hakkını kullanmasından müteselsilen sorumludur.
5. Tüketicinin, **ücretsiz onarım hakkını** kullanması halinde malın;
 - Garanti süresi içinde tekrar arızalanması,
 - Tamiri için gereken azami sürenin aşılması,
 - Tamirinin mümkün olmadığının, yetkili servis istasyonu, satıcı, üretici veya ithalatçı tarafından bir raporda belirlenmesi durumlarında;**tüketici malın bedel iadesini, ayıp oranında bedel indirimini veya imkân varsa malın ayıpsız misli ile değiştirilmesini** satıcıdan talep edebilir. Satıcı, tüketicinin talebini reddedemez. Bu talebin yerine getirilmemesi durumunda satıcı, üretici ve ithalatçı müteselsilen sorumludur.
6. Malın tamir süresi **20 iş gününü** geçemez. Bu süre, garanti süresi içerisinde mala ilişkin arızanın yetkili servis istasyonuna veya satıcıya bildirimi tarihinde, garanti süresi dışında ise malın yetkili servis istasyonuna teslim tarihinden itibaren başlar. Malın arızasının **10 iş günü** içerisinde giderilememesi halinde, üretici veya ithalatçı; malın tamiri tamamlanıncaya kadar, benzer özelliklere sahip başka bir malı tüketicinin kullanımına tahsis etmek zorundadır. Malın garanti süresi içerisinde arızalanması durumunda, tamirde geçen süre garanti süresine eklenir.
7. Malın kullanma kılavuzunda yer alan hususlara aykırı kullanımlarından kaynaklanan arızalar garanti kapsamı dışındadır.
8. Tüketici, garantiden doğan haklarının kullanılmasını ile ilgili olarak çıkabilecek uyuşmazlıklarda yerleşim yerinin bulunduğu veya tüketici işleminin yapıldığı yerdeki **Tüketici Hakem Heyetine veya Tüketici Mahkemesine** başvurabilir.
9. Satıcı tarafından bu **Garanti Belgesinin** verilmesi durumunda, tüketici **Gümrük ve Ticaret Bakanlığı Tüketicinin Korunması ve Piyasa Gözetimi Genel Müdürlüğüne** başvurabilir.

Üretici veya İthalatçı Firma:

WİLO Pompa Sistemleri San. ve Tic. A.Ş.

Orhanlı Mah. Fethat Başaran Cad. No:91 Tuzla

İstanbul/TÜRKİYE

Tel: (0216) 250 94 00

Faks:(0216)250 94 07

E-posta : servis@wilo.com.tr

Satıcı Firma :

Unvanı :

Adresi :

Telefonu :

Faks :

E-posta :

Fatura Tarihi ve Sayısı :

Teslim Tarihi ve Yeri :

Yetkilinin İmzası :

Firmanın Kaşesi :

Yetkilinin İmzası:

Firmanın Kaşesi

WİLO Pompa Sistemleri San. ve Tic. A.Ş.
T.C. 250 94 00 T.C. 250 94 04
A.Ş. Kayıt No: 291 000 0007

Malın

Cinsi : MOTORLU SU POMPASI

Markası : WİLO

Modeli :

Malın

Garanti Süresi : 2 yıl

Azami Tamir Süresi : 20 iş günü

Bandrol ve Seri No :



wilo

GARANTİ İLE İLGİLİ OLARAK MÜŞTERİNİN DİKKAT ETMESİ GEREKEN HUSUSLAR

WILo Pompa Sistemleri San. Ve Tic. A.Ş. tarafından verilen bu garanti, aşağıdaki durumları kapsamaz:

1. Ürün etiketi ve garanti belgesinin tahrip edilmesi.
2. Ürünün kullanma kılavuzunda yer alan hususlara aykırı ve amaç dışı kullanılmasından meydana gelen hasar ve arızalar.
3. Hatalı tip seçimi, hatalı yerleştirme, hatalı montaj ve hatalı tesisattan kaynaklanan hasar ve arızalar.
4. Yetkili servisler dışındaki kişiler tarafından yapılan işletmeye alma, bakım ve onarımlar nedeni ile oluşan hasar ve arızalar.
5. Ürünün tüketiciye tesliminden sonra nakliye, boşaltma, yükleme, depolama sırasında fiziki (çarpma, çizme, kırma) veya kimyevi etkenlerle meydana gelen hasar ve arızalar.
6. Yangın, yıldırım düşmesi, sel, deprem ve diğer doğal afetlerle meydana gelen hasar ve arızalar.
7. Ürünün yerleştirildiği uygunsuz ortam şartlarından kaynaklanan hasar ve arızalar.
8. Hatalı akışkan seçimi ve akışkanın fiziksel veya kimyasal özelliklerinden kaynaklanan hasar ve arızalar.
9. Gaz veya havayla basınçlandırılmış tanklarda yanlış basınç oluşumundan kaynaklanan hasar ve arızalar.
10. Tesisat zincirinde yer alan bir başka cihaz veya ekipmanın görevini yapmamasından veya yanlış kullanımından meydana gelen hasar ve arızalar.
11. Tesisattaki suyun donması ile oluşabilecek hasar ve arızalar.
12. Motorlu su pompasında kısa süreli de olsa kuru (susuz) çalıştırmaktan kaynaklanan hasar ve arızalar.
13. Motorlu su pompasının kullanma kılavuzunda belirtilen elektrik beslemesi toleranslarının dışında çalıştırılmasından kaynaklanan hasar ve arızalar.

Yukarıda belirtilen arızaların giderilmesi, ücret karşılığında yapılır.

WILo Pompa Sistemleri A.Ş. Satış Sonrası Hizmetleri

Orhanlı Mah. Fettah Başaran Cad. No:91 Tuzla
İstanbul/TÜRKİYE
Tel: (0216) 250 94 00
Faks: (0216) 250 94 07
E-posta : servis@wilo.com.tr

wilo



Local contact at
www.wilo.com/contact

Pioneering for You

WILO SE
Wilopark 1
D-44263 Dortmund
Germany
T +49(0)231 4102-0
F +49(0)231 4102-7363
wilo@wilo.com
www.wilo.com