

INSTALLATION

Wall-mounted or recessed cabinet

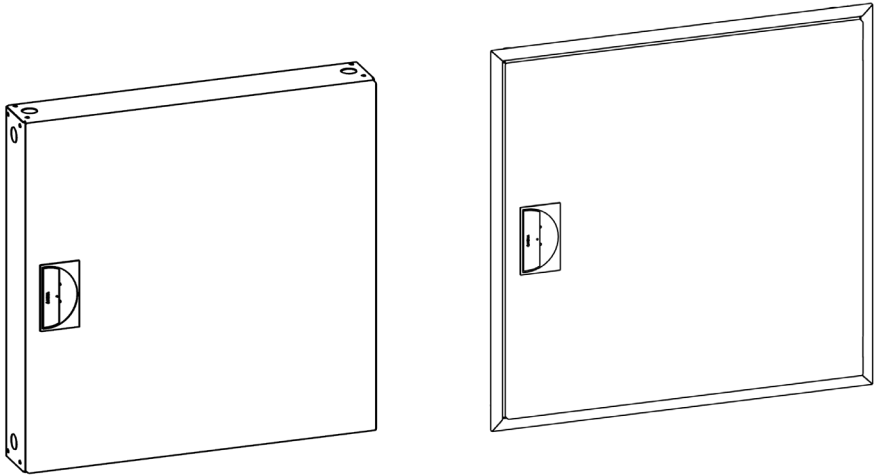

1

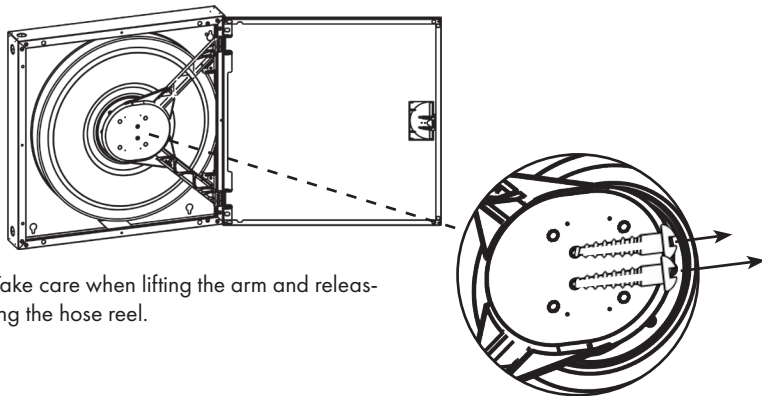

Take care when lifting the arm and releasing the hose reel.

2

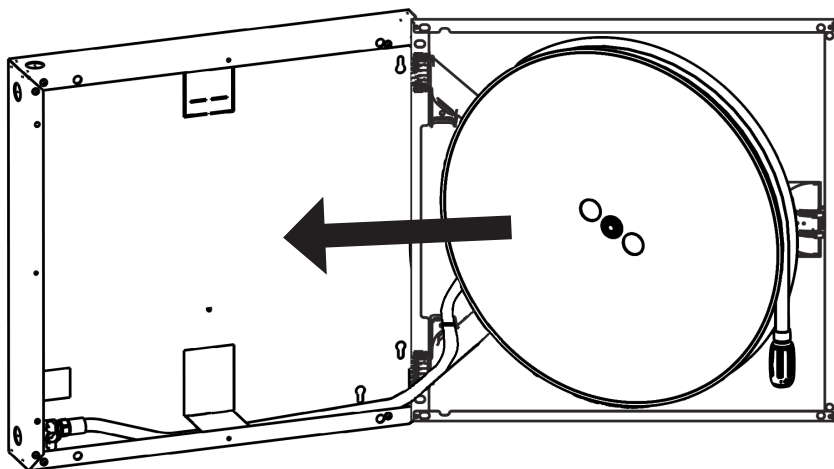

Important : Always function test reel after installation (page 14).

Automatic Valve: Automatic valve inside reel. NOHA recommends a service valve upstream. Record the location of the nearest service valve.

Wall-mount

Page 4

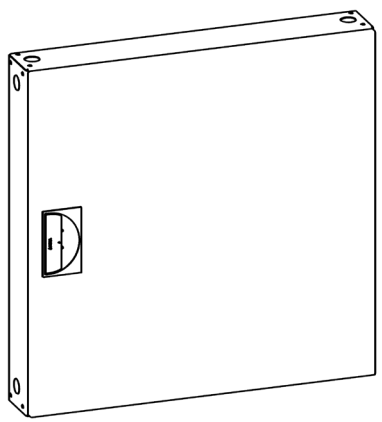

Recessed

Page 6

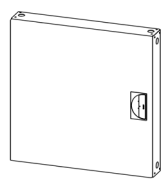
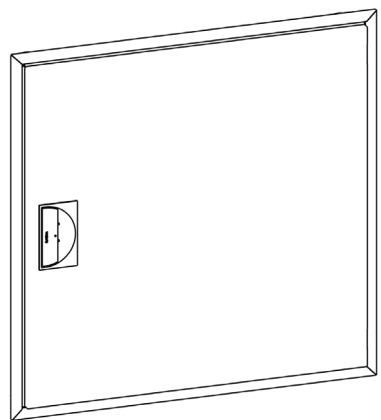

Left hinged cabinet?
Wall-mount/ Recessed
+ Page 10



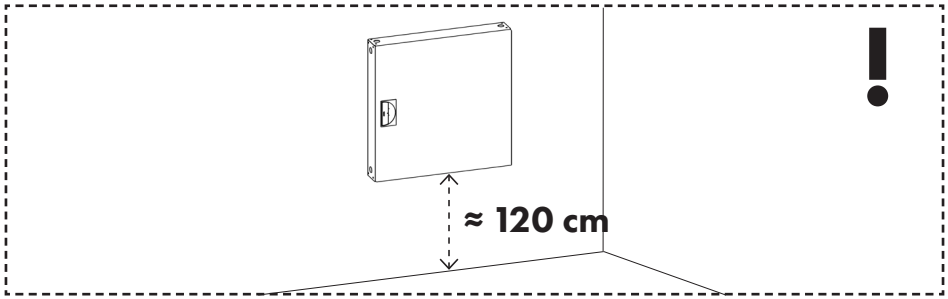

Screws for fixing to wall not included.

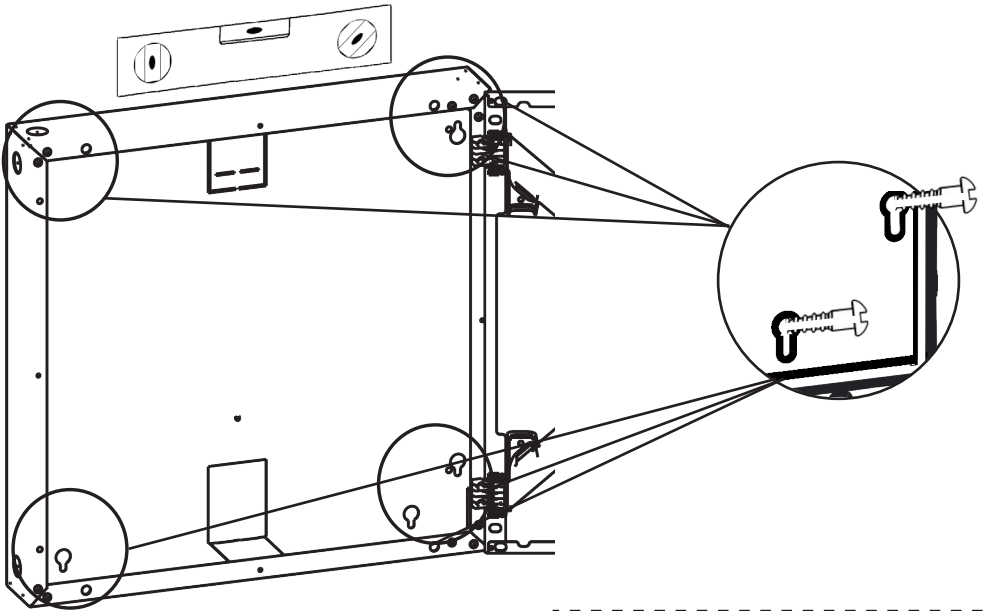

Pre-drill holes for easier installation.

To complete installation:

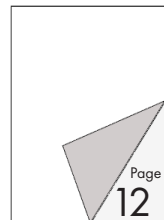

Recessed

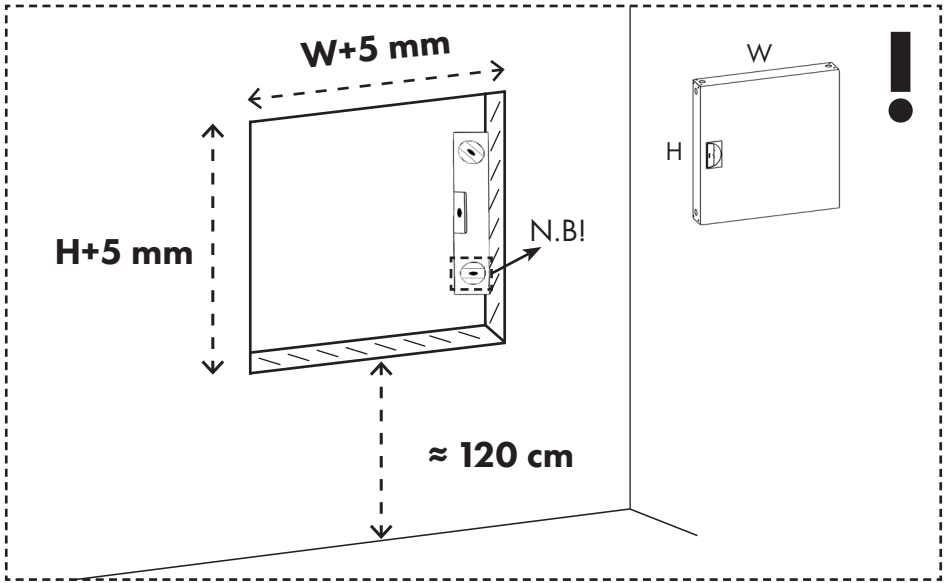

For easier installation, use the guide holes for knock-out punch, and pre-drill holes for fastening.

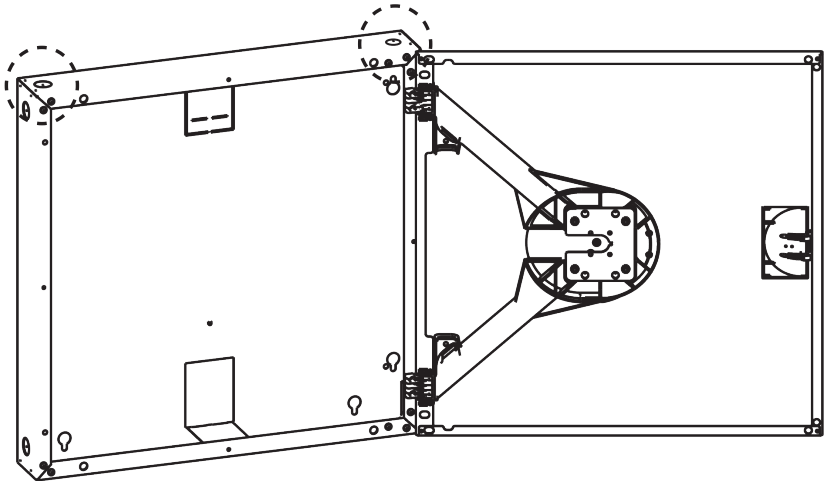

II

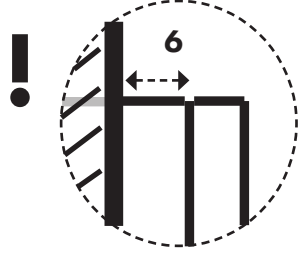
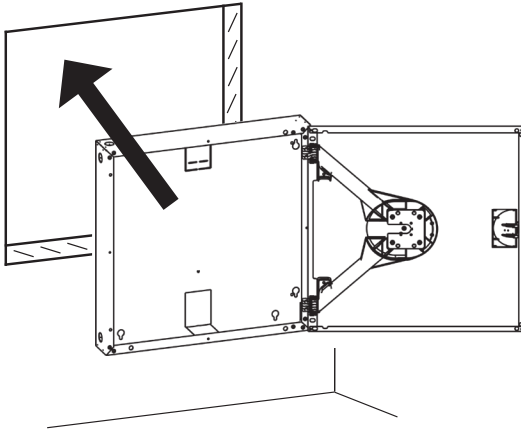

III

Screws for fixing to wall not included.

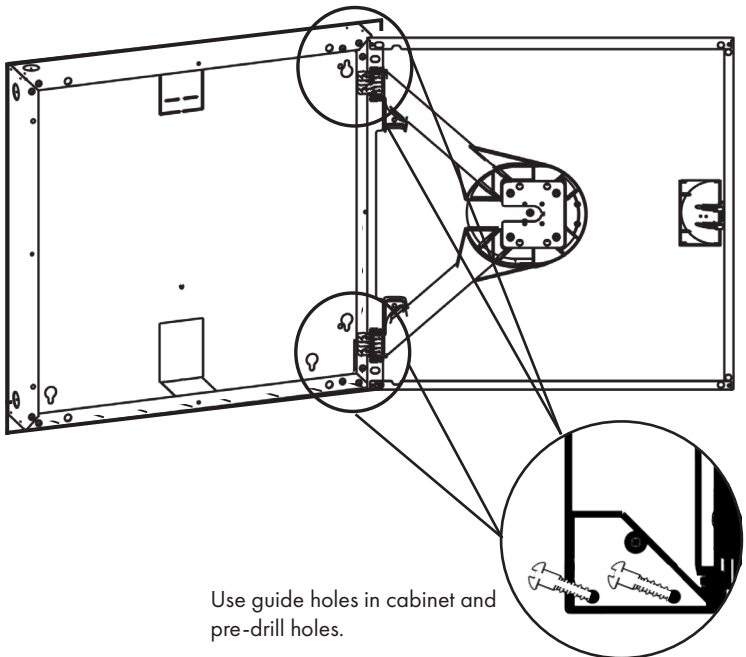

Use guide holes in cabinet and pre-drill holes.

IV

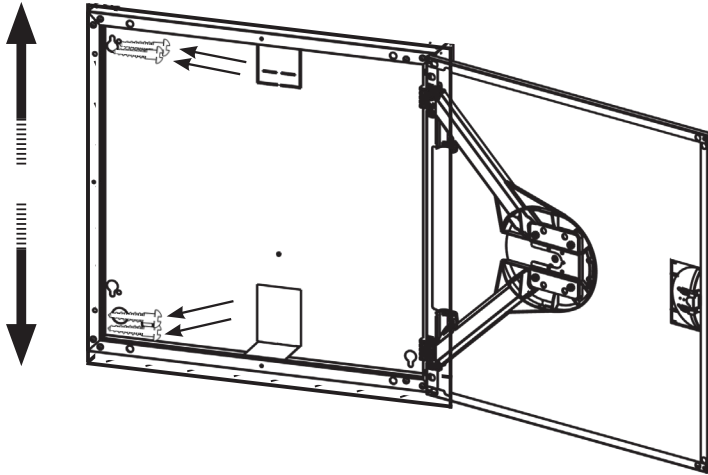

Recessed

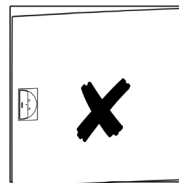
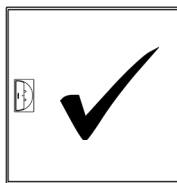
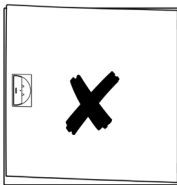

- ! Make sure the door is parallel with frame.
- To adjust, remove fixing screws on top and bottom of the side with handle. Adjust frame up or down accordingly. Make sure door opens freely before fixing screws again.

V

Frame sold
separatly.

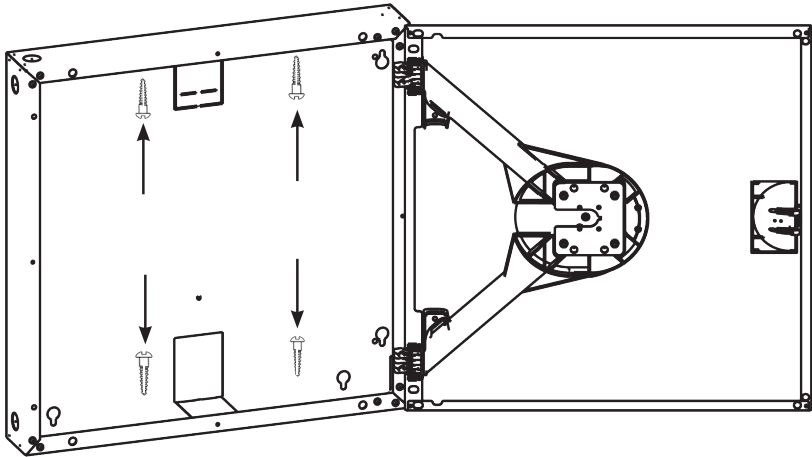
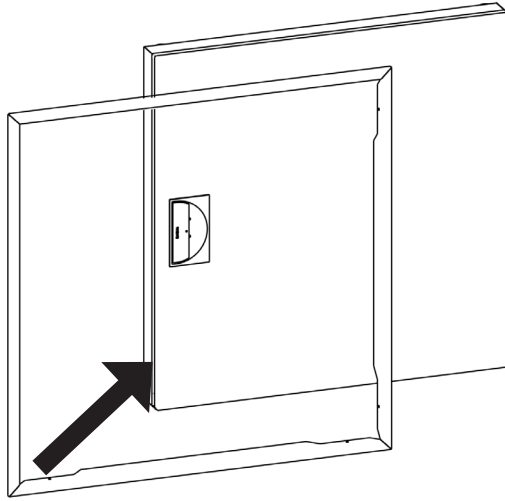

- ! Make sure the door can be completely opened and closed.

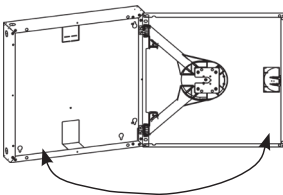

To complete installation:

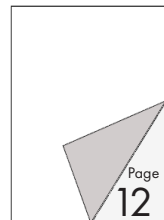

Left hinged

BEFORE MOUNTING:

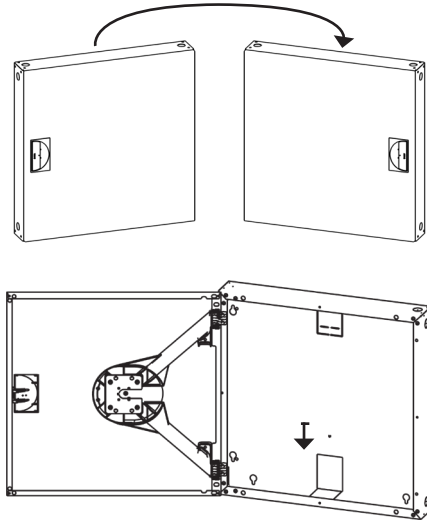

NOHA label for swingarm

After turning cabinet, label on swingarm will be upsidedown.
Fit new label included in the box.

AFTER MOUNTING:

Automatic valve

Do not turn hose direction. Make sure nozzle is visible.

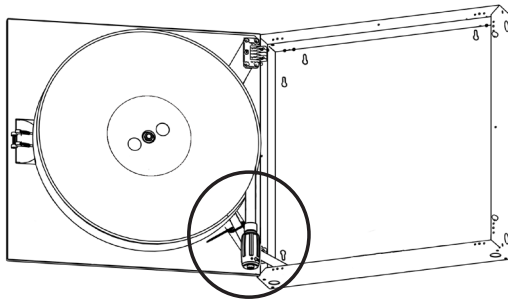

AFTER MOUNTING:

Manual valve

Turn hose direction:

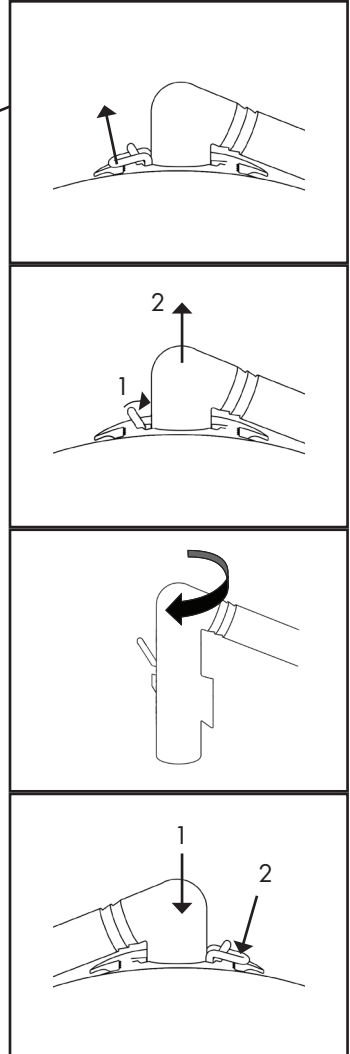
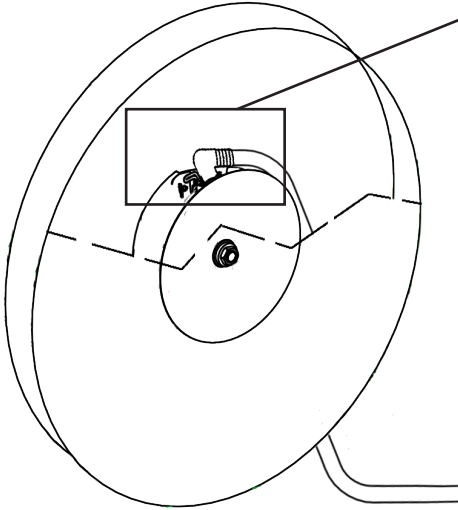

Left hinged

Important : Always function test reel after completing installation (page 14).

3

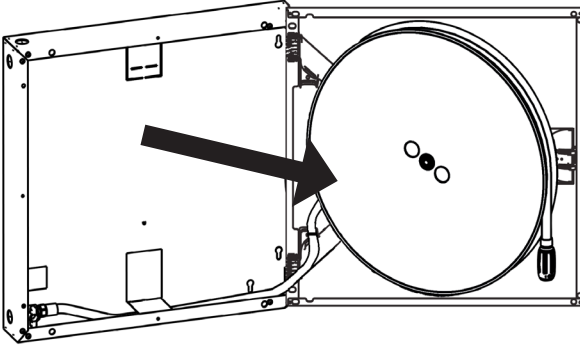

4

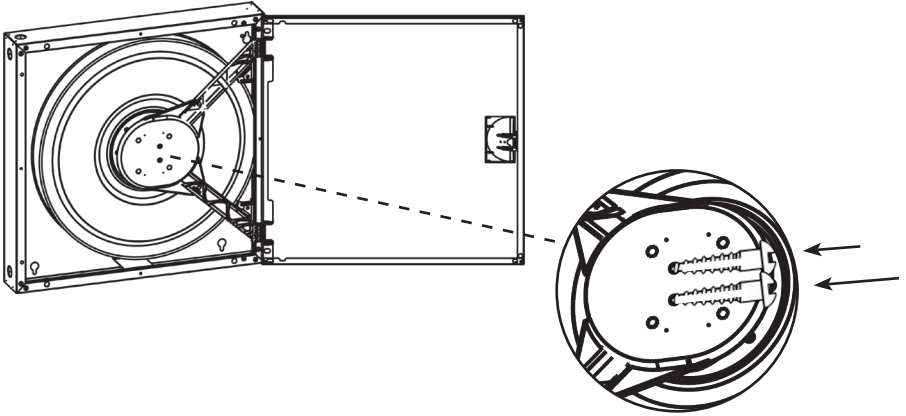

5

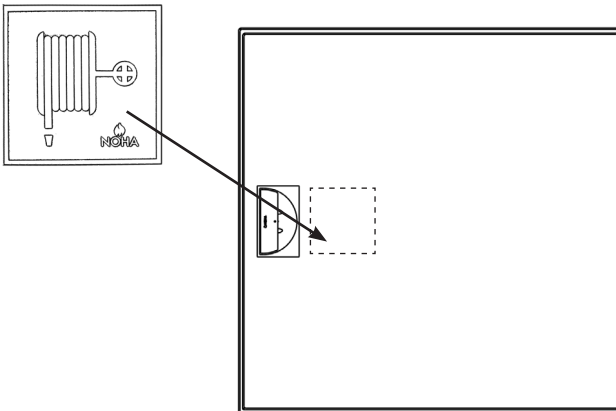

6

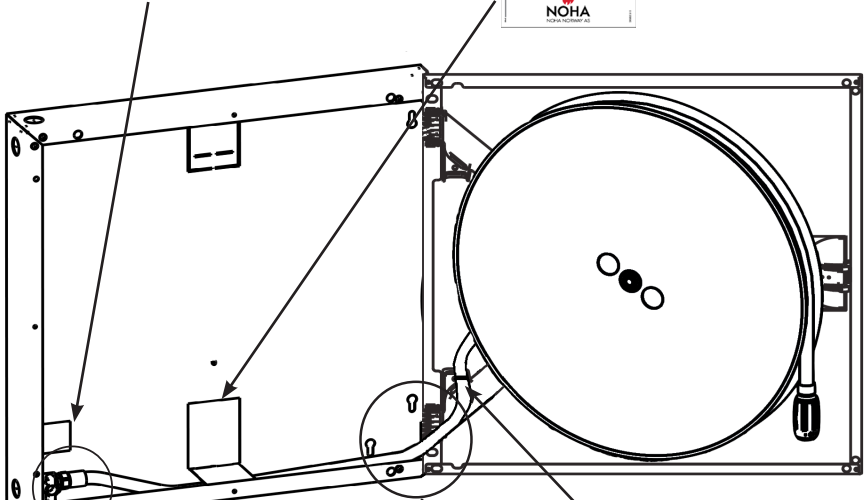
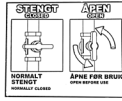
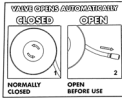

- ! Attach cable tie to secure supply hose to swingarm.
- Make sure the supply hose runs freely without kinks or/and wear.

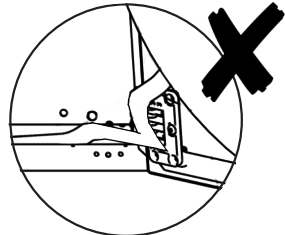
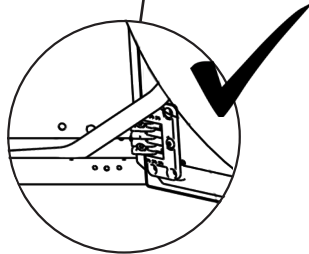
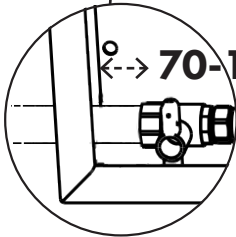

7

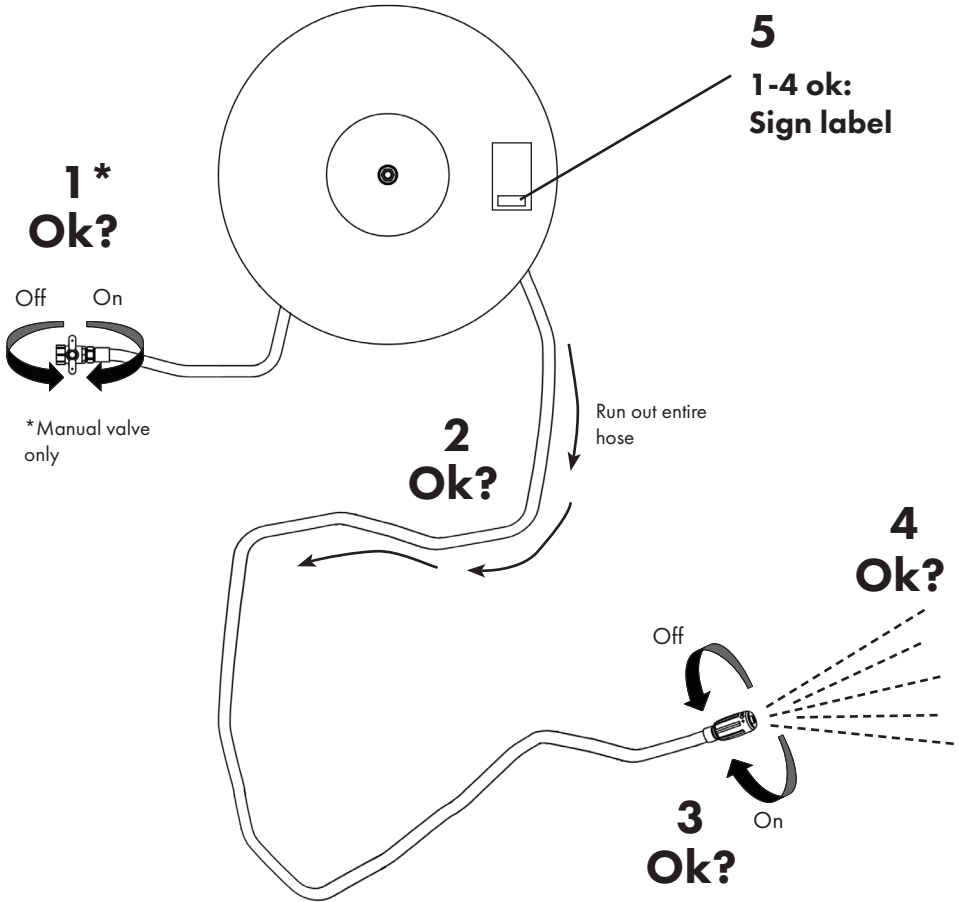

Manuel valve

ENGLISH

Check that door can be opened and closed freely. Close the nozzle, open the valve and run out the whole hose. Make sure the installation is free from leaks. Open nozzle until all air has been bled. Close the nozzle and valve. Rewind the hose. Open the nozzle and relieve the pressure in the hose. Sign the installation label.

NORSK

Sjekk at skåpdør kan åpnes og lukkes fritt. Åpne ventilen, trekk ut hele slangen. Kontroller at installasjonen er tett. Åpne strålerøret til vannet flyter fritt. Steng strålerøret og ventil. Rull inn slangen og trykkavlast slangen. Signer installasjonsetiketten.

SVENSKA

Kontrollera att skåpdörren kan öppnas och stängas fritt. Stäng strålröret, öppna ventilen och dra ut hela slangen. Kontrollera att det inte läcker någonstans. Öppna strålröret tills all luft är borta, stäng sedan strålröret och ventilen. Rulla in slangen och tryckavlasta slangen. Datera och signera installationslappen.

DANSK

Funktionstest. Åbn ventilen, træk hele slangen ud. Kontrollér at installationen er tæt, åbn strålerøret, luk ventil og strålerør, rul slangen ind og trykaflast slangen. Underskriv installationsetiketten.

SUOMI

Tarkista että ovi voidaan avata ja sulkea vapaasti. Sulje suutin ja sulje venttiili ja vedä koko letku ulos kelalta. Varmista että vuotoja ei esiinny asennuksen yhteydessä. Avaa suutin kunnes kaikki ilma on poistunut. Sulje suutin ja uudelleenkelaa letku. Avaa suutin ja vapauta paine letkusta. Allekirjoita tarkastusmerkki.

NEDERLANDS

Beproeving. Open de afsluiter en loop de gehele slangelengte uit. Overtuig u ervan dat de installatie

niet lekt. Open de straalpijp en sluit daarna de afsluiter en de straalpijp weer. Wikkel de slang weer op en laat de druk af. Teken de installation label af.

PORTUGUÊS

Test de funcionamento. Abra válvula e desenrola completamente a mangueira. Verifique que a instalação não tem fugas. Abra a agulheta até o ar todo sair da mangueira. Feche a agulheta e a válvula. Enrola a mangueira e verifica que a válvula está fechada, ou seja abre a agulheta e retira a pressão da mangueira. Assine o autocolante de manutenção.

FRANÇAIS

Fermer la buse, ouvrir la valve et dérouler le tuyau en entier. Assurer que l'installation n'a pas de fuites. Ouvrir la buse jusqu'à ce que tout l'air soit purgé. Fermer la buse et la valve. Réenrouler le tuyau et assurer que la valve est fermée. Ouvrir la buse et relâcher la pression dans le tuyau. Signer la fiche d'installation.

ESPAÑOL

Prueba de funcionamiento. Abrir la válvula y sacar toda la manguera. Asegurarse de que la instalación no presenta fugas. Abrir la boquilla, cerrar la válvula y la boquilla. Rebobinar la manguera y liberar la presión de la manguera. Firmar la etiqueta de instalación.

DEUTSCH

Funktionsprüfung. Düse schließen, Ventil öffnen und Schlauch vollständig ausrollen. Die Installation muss dicht sein. Düse öffnen, bis gesamte Luft entwichen ist. Ventil und Düse schließen. Schlauch wieder aufrollen. Düse öffnen, um den Druck vom Schlauch zu nehmen. Wartungsaufkleber unterschreiben.

Automatic valve

ENGLISH

Check that cabinet door can be opened and closed freely. Close the nozzle and run out the whole hose. Make sure the installation is free from leaks. Open nozzle until all air has been bled. Close the nozzle. Rewind the hose. Make sure the automatic valve is closed by opening the nozzle and relieving the pressure in the hose. Sign the installation label.

NORSK

Sjekk at skapdør kan åpnes og lukkes fritt. Trekk ut hele slangen. Kontroller at installasjonen er tett. Åpne strålerøret til vannet flyter fritt. Steng strålerør og rull inn slangen. Kontroller at automatventilen er stengt ved å trykkavlaste slangen. Signer installasjons-etiketten.

SVENSKA

Kontrollera att skåpdörren kan öppnas och stängas fritt. Stäng strålröret och dra ut hela slangen. Kontrollera att det inte läcker någonstans. Öppna strålröret tills all luft är borta, stäng sedan strålröret. Rulla in slangen och tryckavlasta slangen. Datera och signera installationslappen.

DANSK

Funktionstest. Kontrollér at skabsdøren kan åbnes og lukkes frit. Træk slangen helt ud. Kontrollér at installationen er tæt, åbn strålerør, luk strålerør, rul slangen ind og trykafkast slangen. Underskriv installationset-iketten.

SUOMI

Tarkista että ovi voidaan avata ja sulkea vapaasti. Sulje suutin ja sulje venttiili ja vedä koko letku ulos kelalta. Varmista että vuotoja ei esiinny asennuksen yhteydessä. Avaa suutin kunnes kaikki ilma on poistunut. Kelaa letku ja varmista, automaattinen venttiili on suljettu. Avaa suutin ja vapauta paine letkusta. Allekirjoita tarkastusmerkki.

NEDERLANDS

Beproeving. Open de afsluiter en loop de gehele slangelengte uit. Overtuig u ervan dat de installatie niet lekt. Open de straalpijp en sluit daarna de afslu-

iter en de straalpijp weer. Wickel de slang weer op en laat de druk af. Teken de instalation label af.

PORTUGUÊS

Test de funcionamento. Desenrolar completamente a mangueira. Verifique que a instalação não tem fugas. Abra a agulheta até o ar todo sair da mangueira. Feche a agulheta. Enrola a mangueira e verifica que a válvula automática está fechada, ou seja abre a agulheta e retira a pressão da mangueira. Assine o autocolante de manutenção.

FRANÇAIS

Fermer la buse et dérouler le tuyau en entier. Assurer que l'installation n'a pas de fuites. Ouvrir la buse jusqu'à ce que tout l'air soit purgé. Fermer la buse. Réenrouler le tuyau et assurer que la valve automatique est fermée. Ouvrir la buse et relâcher la pression dans le tuyau. Signer la fiche d'installation.

ESPAÑOL

Prueba de funcionamiento. Sacar toda la manguera. Asegurarse que la instalación no presenta fugas. Abrir la boquilla hasta extraer toda el aire. Cerrar la boquilla. Rebobinar la manguera y asegurarse que la válvula automática esté cerrada. Revisar esto abriendo la boquilla y liberando la presión de la manguera. Firmar la etiqueta de servicio.

DEUTSCH

Funktionsprüfung. Düse schließen und Schlauch vollständig ausrollen. Die Installation muss dicht sein. Düse öffnen, bis die gesamte Luft entwichen ist. Düse schließen. Schlauch wieder aufrollen und überprüfen, dass das Automatikventil geschlossen ist. Die Kontrolle erfolgt durch Öffnen der Düse und Ablassen des Drucks aus dem Schlauch. Wartungsaufkleber unterschreiben.