



Ultrasonic heat and cooling energy meters

UH50..

Ultrasonic heat and cooling energy meters to measure flow and energy in hydronic heating or refrigerant circuits.

- Non-wearing due to non-moving parts
- Approved in accordance with EN 1434 and MID class 2
- Optional mounting position (horizontal or vertical), in return or flow
- Measuring range of flow 1:100 as per EN 1434, 1:1,000 total range
- Choice of communication modules and power supplies
- No settling paths required
- Optical interface as per EN 62056-21
- Self-diagnostics

Application

The UH50.. heat and cooling energy meter acquires energy consumption in a physically correct way. The device consists of flow measuring section and processor unit. The processor unit can be equipped with different sensors, different types of power supply and communication modules. The UH50.. is used to measure the consumption of heat in district heating systems and blocks of flats. It is also suited to measure the consumption of cooling energy (cooling energy only or in combination with thermal energy), or volume flow in hydronic systems.

Restrictions

The UH50.. must not be used in connection with drinking water. Also, the product is not suited for use in systems operating on water-glycol mixtures.

Functions

Ultrasonic measuring principle

The volume flow is acquired based on the ultrasonic measuring principle, free from wear, thanks to the use of non-moving parts.

The quantity of energy supplied to the consumer by the medium during a certain period of time is proportional to the temperature differential of flow and return and the volume flow passing through the meter.

The **water volume** is measured in the measuring tube by ultrasonic pulses which are transmitted in the direction of flow and against the direction of flow. Downstream, the time required by the pulses to travel from the transmitter to the receiver is reduced, upstream it is increased. The water volume is then calculated based on the values measured for the traveling times.

The **flow and return temperatures** are determined using platinum resistors. The heating water volume and the temperature differential of flow and return are multiplied and its product integrated. The result, which is the consumed **quantity of thermal or cooling energy**, is registered and displayed in the physical **units kWh/MWh or MJ/GJ**, the volume in **m³**.

Processor unit

A standard electronic unit is used for all flow rates with identical operation and an integrated service unit.

Optical communication interface

The meter is equipped with an optical communication interface, enabling the device to be read and parameterized on site with the help of the WZR-OP-USB optical read head and the UltraAssist software.

Self-diagnostics

The meter performs constantly self-diagnostics, allowing it to detect a number of mounting or device errors and to display them.

Type summary UH50..

The types of meters listed below are equipped as follows:

Mounting location	Return
Rated pressure	PN 16/PN 25
Length of control cable	1.5 m/3 m
Sensor mounting	Return temperature sensor, integrated in the flow measuring section
	Return temperature sensor, not integrated in the flow measuring section

Temperature sensor type	Pt500, DS M10x1, length 27.5 mm Pt500, DS M10x1 mm, length 38 mm Pt500, Ø 6 mm, length 100 mm Pt500, Ø 6 mm, length 150 mm
Temperature sensor cable length	1.5 m/5 m
Power supply	Without power supply; different types of power supply available
Communication	Without communication; different types of modules available
Approval	As per EN 1434, class 2 MID 2004/22/EG
Energy unit	kWh/MWh

Heat meter

<i>Options</i>	<i>Stock number</i>	<i>Product no.</i>
0.6 m³/h nominal flow rate, mounting length 110 mm, connecting thread G ¾", PN 16, control cable length 1.5 m, Pt500, DS M10x1 mm, sensor length 27.5 mm, cable length 1.5 m, return sensor, integrated in the flow measuring section, energy unit kWh	S55561-F112	UH50-A05-00
1.5 m³/h nominal flow rate, mounting length 110 mm, connecting thread G ¾", PN 16, control cable length 1.5 m, Pt500, DS M10x1 mm, sensor length 27.5 mm, cable length 1.5 m, return sensor, integrated in the flow measuring section, energy unit kWh	S55561-F113	UH50-A21-00
2.5 m³/h nominal flow rate, mounting length 130 mm, connecting thread G 1", PN 16, control cable length 1.5 m, Pt500, DS M10x1 mm, sensor length 27.5 mm, cable length 1.5 m, return sensor, integrated in the flow measuring section, energy unit kWh	S55561-F114	UH50-A36-00
3.5 m³/h nominal flow rate, mounting length 260 mm, connecting thread G 1¼", PN 16, control cable length 1.5 m, Pt500, DS M10x1 mm, sensor length 38 mm, cable length 1.5 m, return sensor, integrated in the flow measuring section, energy unit kWh	S55561-F115	UH50-A45-00
6 m³/h nominal flow rate, mounting length 260 mm, connecting thread G 1¼", PN 16, control cable length 1.5 m, Pt500, DS M10x1 mm, sensor length 38 mm, cable length 1.5 m, return sensor, integrated in the flow measuring section, energy unit kWh	S55561-F116	UH50-A50-00
10 m³/h nominal flow rate, mounting length 300 mm, flanged DN 40, PN 25, control cable length 1.5 m, Pt500, Ø 6 mm, sensor length 100 mm, cable length = 5 m, return sensor, integrated in the flow measuring section, energy unit kWh	S55561-F117	UH50-A61-00
15 m³/h nominal flow rate, mounting length 270 mm, flanged DN 50, PN 25, control cable length 3 m, Pt500, Ø 6 mm, sensor length 100 mm, cable length 5 m, return sensor, not integrated in the flow measuring section, energy unit MWh	S55561-F118	UH50-A65-00

Heat/cooling energy meter

25 m³/h nominal flow rate, mounting length 300 mm, flanged DN 65, PN 25, control cable length 3 m, Pt500, Ø 6 mm, sensor length 100 mm, cable length 5 m, return sensor, not integrated in the flow measuring section, energy unit MWh	S55561-F119	UH50-A70-00
40 m³/h nominal flow rate, mounting length 300 mm, flanged DN 80, PN 25, control cable length 3 m, Pt500, Ø 6 mm, sensor length 150 mm, cable length 5 m, return sensor, not integrated in the flow measuring section, energy unit MWh	S55561-F120	UH50-A74-00
60 m³/h nominal flow rate, mounting length 360 mm, flanged DN 100, PN 25, control cable length 3 m, Pt500, Ø 6 mm, sensor length 150 mm, cable length 5 m, return sensor, not integrated in the flow measuring section, energy unit MWh	S55561-F121	UH50-A83-00
0.6 m³/h nominal flow rate, mounting length 110 mm, connecting thread G ¾", PN 16, control cable length 1.5 m, Pt500, DS M10x1 mm, sensor length 27.5 mm, cable length 1.5 m, return sensor, integrated in the flow measuring section, energy unit kWh	S55561-F122	UH50-C05-00
1.5 m³/h nominal flow rate, mounting length 110 mm, connecting thread G ¾", PN 16, control cable length 1.5 m, Pt500, DS M10x1 mm, sensor length 27.5 mm, cable length 1.5 m, return sensor, integrated in the flow measuring section, energy unit kWh	S55561-F123	UH50-C21-00
2.5 m³/h nominal flow rate, mounting length 130 mm, connecting thread G 1", PN 16, control cable length 1.5 m, Pt500, DS M10x1 mm, sensor length 27.5 mm, cable length 1.5 m, return sensor, integrated in the flow measuring section, energy unit kWh	S55561-F124	UH50-C36-00
3.5 m³/h nominal flow rate, mounting length 260 mm, connecting thread G 1¼", PN 16, control cable length 1.5 m, Pt500, DS M10x1 mm, sensor length 38 mm, cable length 1.5 m, return sensor, integrated in the flow measuring section, energy unit kWh	S55561-F125	UH50-C45-00
6 m³/h nominal flow rate, mounting length 260 mm, connecting thread G 1¼", PN 16, control cable length 1.5 m, Pt500, DS M10x1 mm, sensor length 38 mm, cable length 1.5 m, return sensor, integrated in the flow measuring section, energy unit kWh	S55561-F126	UH50-C50-00
10 m³/h nominal flow rate, mounting length 300 mm, flanged DN 40, PN 25, control cable length 1.5 m, Pt500, Ø 6 mm, sensor length 100 mm, cable length 5 m, return sensor, integrated in the flow measuring section, energy unit kWh	S55561-F127	UH50-C61-00

15 m³/h nominal flow rate, mounting length 270 mm, flanged DN 50, PN 25, control cable length 3 m, Pt500, Ø 6 mm, sensor length 100 mm, cable length 5 m, return sensor, not integrated in the flow measuring section, energy unit MWh	S55561-F128	UH50-C65-00
25 m³/h nominal flow rate, mounting length = 300 mm, flanged DN 65, PN 25, control cable length 3 m, Pt500, Ø 6 mm, sensor length = 100 mm, cable length = 5 m, return sensor, not integrated in the flow measuring section, energy unit MWh	S55561-F129	UH50-C70-00
40 m³/h nominal flow rate, mounting length 300 mm, flanged DN 80, PN 25, control cable length 3 m, Pt500, Ø 6 mm, sensor length 150 mm, cable length 5 m, return sensor, not integrated in the flow measuring section, energy unit MWh	S55561-F130	UH50-C74-00
60 m³/h nominal flow rate, mounting length 360 mm, flanged DN 100, PN 25, control cable length 3 m, Pt500, Ø 6 mm, sensor length 150 mm, cable length 5 m, return sensor, not integrated in the flow measuring section, energy unit MWh	S55561-F131	UH50-C83-00

Note Other types available on request.

Power supply modules

<i>Component (optional)</i>	<i>Stock number</i>	<i>Product no.</i>
Power pack AC 230 V , cable length 1.5 m	S55563-F111	WZU-AC230-15
Power pack AC 230 V , cable length 5 m	LYU:WZU-AC230-50	WZU-AC230-50
Power pack AC 230 V , cable length 10 m	LYU:WZU-AC230-100	WZU-AC230-100
Power pack AC/DC 24 V , with terminals, standard battery for 6 years, complete with fastener	S55563-F112	WZU-ACDC24-00
Standard battery (2 AA), for 6 years , complete with fastener, application standard pulses, standard M-bus readout (every 15 minutes)	S55563-F114	WZU-BA+GUM
Universal battery (D-cell), for 6 and 16 years respectively , Applications for 16 years: Standard pulses, standard M-bus readout (every 15 minutes), Applications for 6 years: All communication modules	S55563-F113	WZU-BDS

Note Other types available on request.

Communication modules WZU-GPRS and WZU-GPRS-ANT are supplied complete with power supply. In that case, none of the above mentioned power supply modules need be ordered.

Communication modules

<i>Component (optional)</i>	<i>Stock number</i>	<i>Product no.</i>
Pulse module with 2 channels to output standard or "definable" pulses	S55563-F107	WZU-P2
Pulse module with opto MOS output	LYU:WZU-P2L	WZU-P2L

<i>Component (optional)</i>	<i>Stock number</i>	<i>Product no.</i>
M-bus module for heat and heat/cooling energy meters, generation 2, recommended up to firmware 5.14	S55563-F109	WZU-MB
M-bus module for heat and heat/cooling energy meters, generation 4, firmware 5.15 and higher from meter firmware 5.17 and module firmware 4.10	S55563-F110	WZU-MB-G4
M-bus module with 2 pulse inputs for heat and heat/cooling energy meters, generation 4, firmware 5.15 and higher from meter firmware 5.17 and module firmware 4.10	S55563-F108	WZU-MI
CL module , digital passive 20-mA interface	LYU:WZU-CL	WZU-CL
RF module, 433 MHz , with integrated antenna and 2 pulse inputs	LYU:WZU-RM	WZU-RM
RF module, 433 MHz , with external antenna and 2 pulse inputs	LYU:WZU-RM-EXT	WZU-RM-EXT
RF module, 868 MHz , with integrated antenna only from meter firmware 5.17: NTA standard/ DSMR2.2+	LYU:WZU-RF	WZU-RF
RF module, 868 MHz , with external antenna only from meter firmware 5.17: NTA standard/ DSMR2.2+	LYU:WZU-RF-EXT	WZU-RF-EXT
GPRS module with external antenna (magnetic attachment) and with power pack AC 110...230 V	LYU:WZU-GPRS	WZU-GPRS
GPRS module with external antenna (for screw mounting) and with power pack AC 110...230 V	LYU:WZU-GPRS-ANT	WZU-GPRS-ANT
GSM module with 2 pulse inputs	LYU:WZU-GM	WZU-GM
Analog module	LYU:WZU-AM	WZU-AM
Power pack for analog module	LYU:WZR-NE	WZR-NE

Note

Other types available on request.

Temperature sensors

<i>Component</i>	<i>Stock number</i>	<i>Product no.</i>
Pt500, DS M10x1 mm, sensor length 27.5 mm, cable length 1.5 m	LYU:WZU5-2815	WZU5-2815
Pt500, DS M10x1 mm, sensor length 27.5 mm, cable length 2.5 m	LYU:WZU5-2825	WZU5-2825
Pt500, DS M10x1 mm, sensor length 38 mm, cable length 1.5 m	LYU:WZU5-3815	WZU5-3815
Pt500, DS M10x1 mm, sensor length 38 mm, cable length 2.5 m	LYU:WZU5-3825	WZU5-3825
Pt500, Ø 5.2x45 mm, cable length 1.5 m	LYU:WZU5-4515	WZU5-4515
Pt500, PS Ø 5.2x45 mm, cable length 5 m	LYU:WZU5-4550	WZU5-4550
Pt500, PL Ø 6x100 mm, cable length 2 m	LYU:WZU5-1020	WZU5-1020
Pt500, PL Ø 6x100 mm, cable length 5 m	LYU:WZU5-1050	WZU5-1050
Pt500, PL Ø 6x150 mm, cable length 2 m	LYU:WZU5-1520	WZU5-1520
Pt500, PL Ø 6x150 mm, cable length 5 m	LYU:WZU5-1550	WZU5-1550

Mounting accessories

Fittings

<i>Component (optional)</i>	<i>Stock number</i>	<i>Product no.</i>
Mounting set for L = 110 mm, consisting of: - 1 spacer ¾", length = 110 mm - 2 fittings G ¾ B" with coupling nut G ¾ B" - 1 protection pocket for flow sensor Ø 5.2x45 mm, incl. gasket made of copper - 2 gaskets	LYU:99T34110	99T34110
Mounting set for L = 130 mm consisting of: - 1 spacer 1", length = 130 mm - 2 fittings G 1 B" with coupling nut G 1 B" - 1 protection pocket for flow sensor Ø 5.2x45 mm, incl. gasket made of copper - 2 gaskets	LYU:99T01130	99T01130
Mounting kit, consisting of: - 2 coupling nuts G ¾" - 2 inserts R ½" - 2 gaskets	S55563-F124	WZM-E34
Mounting kit, consisting of: - 2 coupling nuts G 1" - 2 inserts R ¾" - 2 gaskets	S55563-F123	WZM-E1
Mounting kit, consisting of: - 2 coupling nuts G 1¼" - 2 inserts R 1" - 2 gaskets	LYU:WZM-E54	WZM-E54
Mounting kit, consisting of: - 2 coupling nuts G 2" - 2 inserts R 1½" - 2 gaskets	LYU:WZM-E2.1	WZM-E2.1
Adapter from 110 mm to 130 mm, consisting of: - 1 fitting G ¾ B" to G ¾ B" - 2 gaskets	LYU:WZM-V130	WZM-V130
Adapter from 110 mm to 130 mm, consisting of: - 1 fitting G ¾ B" to G 1 B" - 2 gaskets G ¾" - 2 gaskets G 1"	LYU:WZM-V130.G1	WZM-V130.G1
Adapter from 110 mm to 165 mm, consisting of: - 2 fitting G ¾ B" to G ¾ B" - 4 gaskets	LYU:WZM-V165	WZM-V165
Adapter from 110 mm to 190 mm, consisting of: - 1 fitting G ¾ B" to G 1 B" - 2 gaskets G ¾" - 2 gaskets G 1"	LYU:WZM-V190	WZM-V190

Spacers and gaskets

Spacer G ¾", length 110 mm, incl. 2 gaskets	LYU:WZM-G110	WZM-G110
Spacer G 1", length 130 mm, incl. 2 gaskets	LYU:WZM-G130	WZM-G130
Spacer G 1", length 190 mm, incl. 2 gaskets	LYU:WZM-G190	WZM-G190
Spacer G 1¼", length 260 mm, incl. 2 gaskets	LYU:WZM-G260	WZM-G260
Spacer DN 20, length 190 mm, PN 16,	LYU:WZM-F190	WZM-F190

incl. 2 gaskets		
Spacer DN 25, length 260 mm, PN 16, incl. 2 gaskets	LYU:WZM-F260	WZM-F260
Spacer DN 50, length 270 mm, PN 16, incl. 2 gaskets	LYU:WZM-F270	WZM-F270
Spacer DN 40, length 300 mm, PN 16, incl. 2 flat gaskets	LYU:WZM-F300	WZM-F300
Spacer DN 65, length 300 mm, PN 16, incl. 2 flat gaskets	LYU:WZM-F300.65	WZM-F300.65
Spacer DN 80, length 300 mm, PN 16, incl. 2 flat gaskets	LYU:WZM-F300.80	WZM-F300.80
Spacer DN 100, length 360 mm, PN 25, incl. 2 flat gaskets	LYU:WZM-F360.10- 25	WZM-F360.100- 25
Sealing disk G ¾", for threaded connection R ½"	LYU:9060944002	9060944002
Sealing disk G 1", for threaded connection R ¾"	LYU:9060944003	9060944003
Sealing disk G 1¼", for threaded connection R 1"	LYU:9060944004	9060944004
Sealing disk for DN 40, q _p 10 m ³ /h	LYU:9060944024	9060944024
Sealing disk for DN 50, q _p 15 m ³ /h	LYU:9060944025	9060944025
Sealing disk for DN 65, q _p 25 m ³ /h	LYU:9060944026	9060944026
Sealing disk for DN 80, q _p 40 m ³ /h	LYU:9060944027	9060944027
Sealing disk for DN 100, q _p 60 m ³ /h	LYU:9060944028	9060944028

Accessories

Welding sleeve with threaded hole for temperature sensor DS M10x1 mm	S55563-F121	WZT-G10
Welding sleeve G ½", 45° to pipe axis, with threaded hole G ½"	S55563-F122	WZT-G12
Welding sleeve G ½", 90° to pipe axis, with threaded hole G ½"	LYU:WZT-GLG	WZT-GLG
Ball valve Rp ½" for mounting the sensor DS M10 x 1 mm, length 28 mm, max. water temperature 130 °C, PN 25	S55563-F104	WZT-K12
Ball valve Rp ¾" for mounting the sensor DS M10 x 1 mm, length 28 mm, max. water temperature 130 °C, PN 25	S55563-F120	WZT-K34
Ball valve Rp 1" for mounting the sensor DS M10 x 1 mm, length 28 mm, max. water temperature 130 °C, PN 25	S55563-F119	WZT-K1
Ball valve R ½" with union nut G ¾"	LYU:WZT-K12-34	WZT-K12-34
Ball valve R ¾" with union nut G ¾"	LYU:WZT-K34-34	WZT-K34-34
Ball valve R ¾" with union nut G 1"	LYU:WZT-K34-1	WZT-K34-1
Ball valve R 1" with union nut G 1"	LYU:WZT-K1-1	WZT-K1-1
Adapter for ball valve to install sensor DS M10x1 mm, length 38 mm	S55563-F105	9930128002
Adapter G ⅜ B" with threaded hole for sensor DS M10x1 mm, incl. gasket G ⅜" made of copper	LYU:WZT-A38	WZT-A38
Adapter G ½ B" with threaded hole for sensor DS M10x1 mm, incl. gasket G ½" made of copper	S55563-F116	WZT-A12
Adapter G ¾ B" with threaded hole for sensor DS M10x1 mm, incl. gasket G ¾" made of copper	LYU:WZT-A34	WZT-A34

Protection pocket G ½ B" made of stainless steel, with threaded hole G ¼", mounting length 100 mm, incl. gasket G ½" made of copper	LYU:WZT-S100	WZT-S100
Protection pocket G ½ B" made of stainless steel, with threaded hole G ¼", mounting length 150 mm, incl. gasket G ½" made of copper	LYU:WZT-S150	WZT-S150
Protection pocket G ½ B" made of brass, Ø 5.2x35 mm for sensor Ø 5.2x45 mm	S55563-F103	WZT-M35
Protection pocket G ½ B" made of brass, Ø 5.2x50 mm for sensor Ø 5.2x45 mm	LYU:WZT-M50	WZT-M50
Adapter for protection pocket Ø 6 mm to install temperature sensor Ø 5.2x45 mm	LYU:WZT-R32	WZT-R32
Kit for mounting sensor Ø 5.2x45 mm, consisting of: - 1 sensor fitting DS M10x1 mm, brass - 1 O-ring - 1 grooved pin	LYU:9930127002	9930127002
Adapter kit, consisting of: - 1 plastic adapter Ø 5.2x45 mm - 1 mounting aid for sensor Ø 5.2x45 mm - 2 O-rings	LYU:9956230	9956230
Mounting set G ½ B" with threaded hole G ¼" for direct mounting of long sensors	LYU:WZT-A100	WZT-A100
Sealing disk for temperature sensor DS M10x1 mm, Ø 8.6/5.3, size 1 mm	LYU:9060944001	9060944001
Sealing disc ½" made of copper	LYU:9060948	9060948
Service key for calibration mode	LYU:9089885	9089885
Mounting plate for top hat rail	LYU:WZU-MH	WZU-MH
Self-lock seal with sealing wire	LYU:9956186001	9956186001

Programming accessories

Optical read head with USB interface for PC	LYU:WZR-OP-USB	WZR-OP-USB
- UltraAssist standard, first license, CD with dongle for printer interface	LYU:WZX-UA-SED	WZX-UA-SED
- UltraAssist standard, second license, with dongle for printer interface	LYU:WZX-UA-SFD	WZX-UA-SFD
- UltraAssist standard, first license, CD with dongle as PCMCIA card	LYU:WZX-UA-SEP	WZX-UA-SEP
- UltraAssist standard, second license, with dongle as PCMCIA card	LYU:WZX-UA-SFP	WZX-UA-SFP
- UltraAssist standard, first license, CD with dongle for USB interface	LYU:WZX-UA-SEU	WZX-UA-SEU
- UltraAssist standard, second license, with dongle for USB interface	LYU:WZX-UA-SFU	WZX-UA-SFU

Read and parameterization software

The UltraAssist Light read and parameterization software is free and available on request.

Ordering

When ordering, please give quantity, description, product no. and stock number.

Order numbers

Product no.	Stock number	Description
UH50-A36-00	S55561-F114	Ultrasonic heat meter

Scope of delivery

The UH50.. is supplied complete with Mounting Instructions in different languages:

Languages

The Mounting Instructions are supplied in 18 languages:

Bulgarian, Chinese, Croatian, Czech, Dutch, English, French, German, Greek, Hungarian, Italian, Norwegian, Polish, Russian, Slovakian, Slovenian, Spanish, and Turkish.

Technical design

Metering accuracy as per EN 1434

The diagram below shows the typical metering accuracy of the UH50.. in comparison with the error limits as per to EN 1434, class 2.

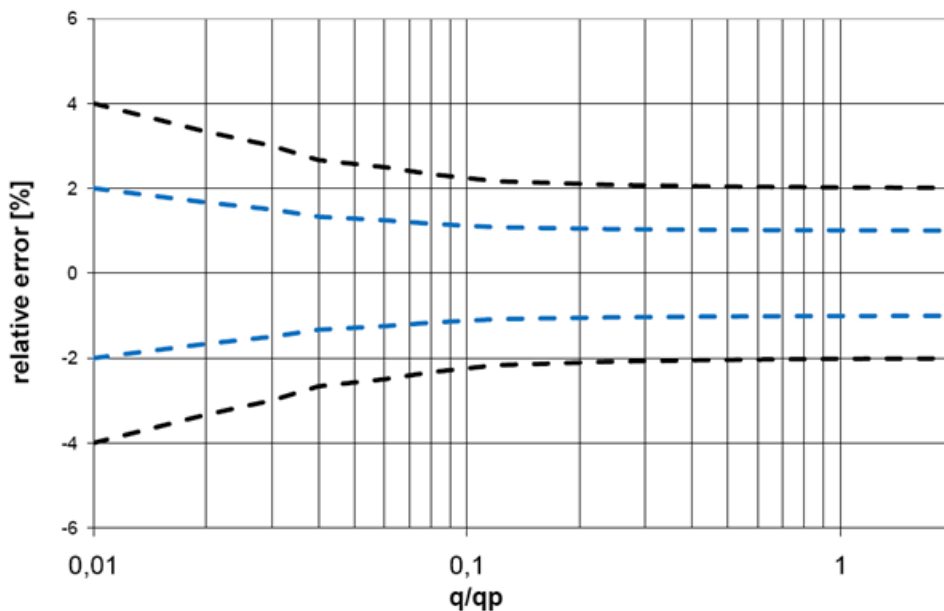

Key:
 - - - UH50.. typical
 - - - EN 1434, class 2

Pressure drop characteristic

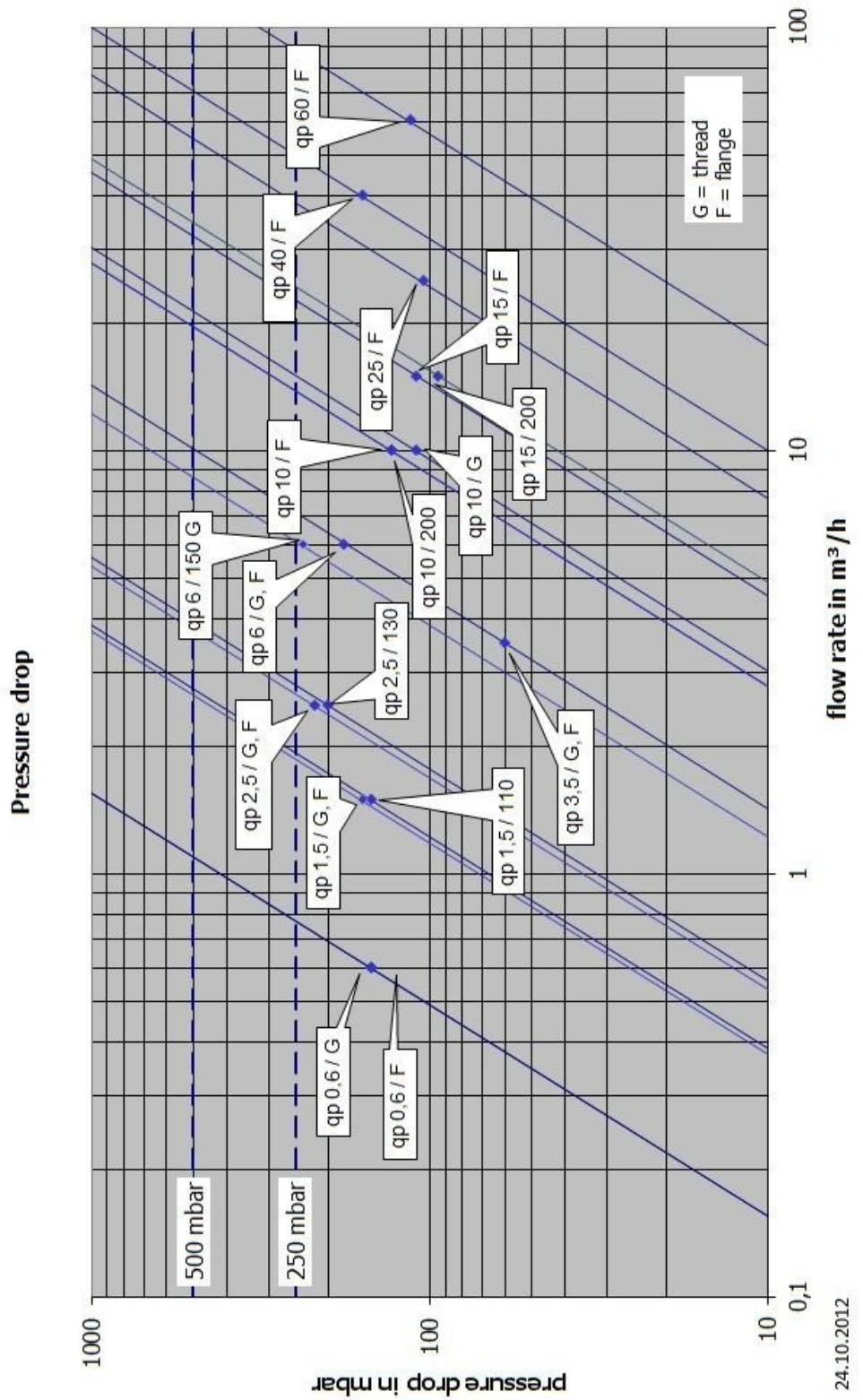

The meter displays current readings in kWh, MWh, MJ or GJ.
 The selection available on the meter is merely kWh or MWh and MJ or GJ.

Resolution of display

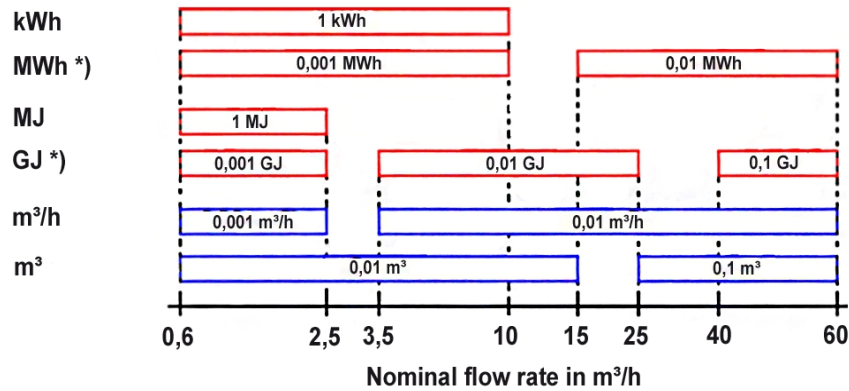

*) Decimal places "blinking", "static", or "suppressed"

To avoid reading errors, the decimal places of displayed values are outlined. Calibrated values are identified by a star symbol.

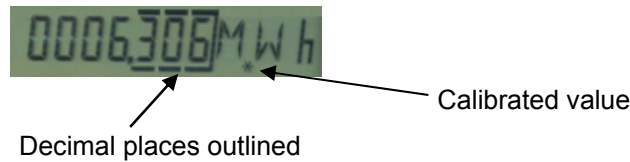

The number of decimal places of a value depends on the selected measuring path and the selected unit.

The meter's displays are arranged in 5 loops:

- 1 user loop
- 4 service loops

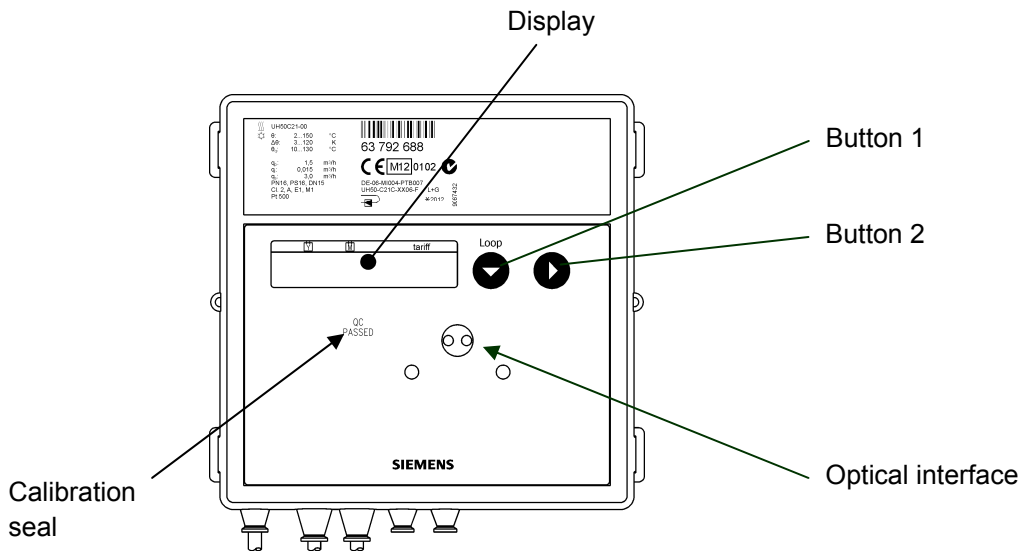

A short press on button 1 enables the required loop to be selected. After the last loop, the user loop reappears.
 When pressing button 2, the values in the respective loop can be read. After the last value of a loop, the first value reappears.

Note

The range of display and the displayed data may deviate from this description and certain button functions may be disabled, depending on the parameter settings made on the meter.

User loop LOOP 0	F -----	Error message with error code number (only in case of error)
	.. 1234567 kWh	Accumulated energy with tariff state
	T' 1234567 kWh	Tariff register 1 (optional)
	1234567 m ³	Accumulated volume
	8888888 kWh	Segment test
Service loop LOOP 1	1234 m/h	Current flow rate
	90.4 kW	Current power
	TV 9.16 °C	Current flow/return temperature at 2-second intervals
	TR 56.2 °C	
	Od 1234 h	Operating time
	Pd 1234 h	Operating time with flow rate
	Fd 123 h	Missing time
	K 12345678	Property number, 8 digits
	D 10.05.06	Date
	SD 3.05.--	Yearly set day (DD.MM)
	T 1234567 kWh	Energy previous year on set day
	FWI 5-00	Volume for previous year on set day
Service loop LOOP 2	MP 60 min	Measuring period for maximum calculation
Service loop LOOP 3	0.07.11 M	Monthly value (set day)
	1234567 kWh	Energy on set day
	T' 1234567 kWh	Tariff register 1 on set day
	1234567 m ³	Volume on set day
	Ma 3899 m/h	Max. flow rate on set day, at 2-second intervals with date stamp
	St 1306.11	
	Ma 2889 kW	Max. power on set day, at 2-second intervals with date stamp
	St 1306.11	
	MV 988 °C	Max. temperatures on set day, at 2-second intervals with date stamp for flow and return maximum
	St 1306.11	
	MR 877 °C	
	St 1306.11	
Fd 123 h	Missing time count on set day	

Note

If the number of months to be read is changed via the service software, this also affects the number of months that can be called up via the LCD.

**Service loop
LOOP 4**

T2 0000 m/h	Current tariff,
' 0000 m/h	at 2-second intervals with threshold value 1
FP 200 SEC	Measuring interval for flow rate
TP 30 SEC	Measuring interval for temperature
Modul 1 MB	Module 1: M-bus module
FP1 127	M-bus primary address 1
A 12345678	M-bus secondary address 8-digit
Modul 2-1 EE	Module 2: Pulse module; channel 1 = energy, channel 2 = volume, at 2-second intervals
Modul 2-2 EV	
PO1 12500Wh/l	Valency for energy pulses *)
PO2 00250 l/l	Valency for volume pulses *)
PO3 2ms	Pulse duration in ms *)
	*) For "fast pulses"

Previous year's values

The processor unit stores the meter readings of energy, volume, the tariff register, missing time, and flow rate measuring time as well as the current maximum of flow rate, power, temperature differential, flow temperature, and return temperature with their date stamps on a yearly set day.

Monthly values

The processor unit stores the meter readings of energy, volume, the tariff register, missing time, and flow rate measuring time as well as the monthly maxima of flow rate, power, temperature differential, flow temperature and return temperature with their date stamp **for up to 60 months** on the set day of each month.

Note

The standard time used is the Central European Time (CET). If daylight-saving time is activated, storage will be performed accordingly. Previous year's values and monthly values can also be read out via the optical and the 20-mA interface.

Error messages

The meter performs constantly self-diagnostics and can display various error messages.

Error code	Error	Notes on service
FL nEG	Wrong direction of flow	Check flow or installation direction; correct if necessary
If necessary, alternating with:		
DIFF nEG	Negative temperature differential	Check place of installation of sensors; replace if required
If necessary, alternating with:		
F0	Flow cannot be measured	Air in the measuring section/pipe; vent the pipe (as supplied)
F1	Interruption in the flow temperature sensor	Check sensor; replace if required
F2	Interruption in the return temperature sensor	Check sensor; replace if required
F3	Electronics for temperature assessment defective	Replace meter
F4	Battery exhausted; problem in connection with power supply	Replace battery; check connection
F5	Short-circuit in the flow temperature sensor	Check sensor; replace if required
F6	Short-circuit in the return temperature sensor	Check sensor; replace if required

F7	Fault in the internal memory	Replace meter
F8	Errors F1, F2, F3, F5, or F6 for more than 8 hours, detection of tampering attempts. No further measurements are made	Action dependent on error code; error message F8 must be reset by service department
F9	Error in the electronics	Replace meter

Standard parameters

The UH50.. comes programmed as follows:

- Set day [TT.MM]: 01.01

Mounting

Flow measuring section

Note

The mounting position is optional, the mounting location (return or flow) must be in accordance with the type of meter used.

The flow measuring section must always be installed in the return.

Settling paths upstream of and downstream from the meter are not required. If the meter is installed in the common return of 2 heating circuits (e.g. space heating and DHW), the mounting position must be in an adequate distance from the T-piece (min. 10 x DN) to allow the different water temperatures to properly mix.

Before installing the meter, the system must be thoroughly flushed. Install the flow measuring section between 2 shutoff valves with the arrow pointing in the direction of flow. The sensors must be mounted in the same water circuit as the flow measuring section (observe mixing). The cables must not be segregated, shortened or extended. Connect the individual wires according to the wiring diagram printed on the meter. The sensors can be fitted in T-pieces or ball valves, or can be immersed, either directly or in pockets (national regulations must be observed). In any case, the end of the sensors' probe must extend to at least the pipe center. Temperature sensors and fittings must be sealed to prevent tampering. Overpressure must prevent cavitation across the entire measuring range, that is, at least 1 bar with q_p and approximately 2 bar with q_s (at 80 °C).

Only authorized persons are allowed to remove and replace calibration seals when carrying out service work.

Ball valve

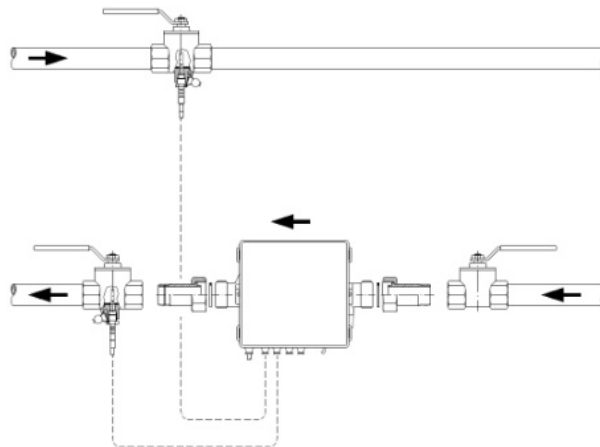

Example of mounting with a ball valve (recommended up to DN 25)

Welded sleeve with protection pocket

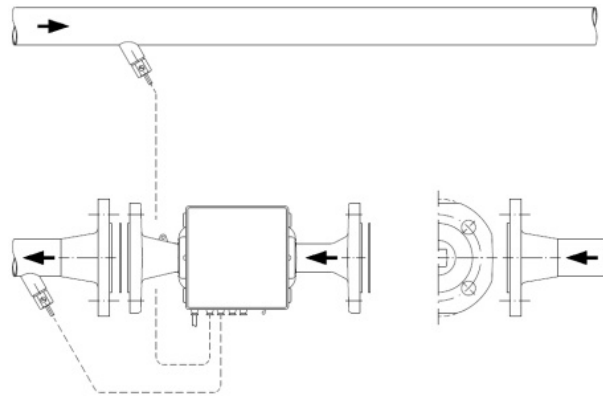

Example of mounting with protection pockets (recommended above DN 25)

Required position of the cooling energy meter

When fitting a **cooling energy** or **combined heat/cooling energy meter**, make sure the black cover on the measuring tube points to the side or downward to prevent condensation. The protection pockets should also be fitted to the side or should point downward. The processor unit must be mounted away from the flow measuring section (e.g. on the wall). Make sure that condensation cannot run along the connected cables, entering the processor unit (forming a loop downward).

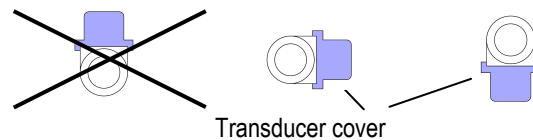

Permissible mounting position when metering cooling energy

Processor unit

The ambient temperature of the processor unit must not exceed 55 °C. Avoid direct sunlight.

When fitting the unit, ensure that water cannot enter during operation.

For water temperatures between 10 °C and 90 °C, the processor unit may be left on the flow measuring section or can be fitted to the wall (detached mounting).

For water temperatures above 90 °C or below 10 °C, the processor must be secured to the wall (split mounting).

To fit the processor unit to the wall, remove it from the flow measuring section and undo the screws of the adapter plate. The latter must then be secured to the wall so that the processor unit can be replaced on the adapter plate, snapping into place.

Power supply

The UH50.. can be powered by a power pack or a battery.

Automatic mains detection

The power pack detects whether line voltage is present. This signal is forwarded to the UH50.., enabling the meter to automatically detect whether it is powered by the battery or the power pack.

Power packs



Power pack AC/DC 24 V
WZU-ACDC24-00



Power pack AC 230 V
WZU-AC230-15
WZU-AC230-50
WZU-AC230-100

Batteries



Standard battery (2 AA)
WZU-BA+GUM



Universal battery (D-cell)
WZU-BDS

Battery life

The life of a battery depends on the type of battery and the requirements (e.g. short timebase, analog module, etc.).

Requirements (with timebase Q = 4 s and T = 30 s)	Battery life	
	6 years	16 years
Standard pulses M-bus readout (max. every 15 minutes), CL module	2 AA	D-cell
M-bus fast readout, fast pulses, analog module, RF module	D-cell	--

Communication modules

The communication modules are connected via a 6-pole reaction-free plug, enabling them to be installed or replaced at any time.

Compliance with ESD regulations must be ensured.

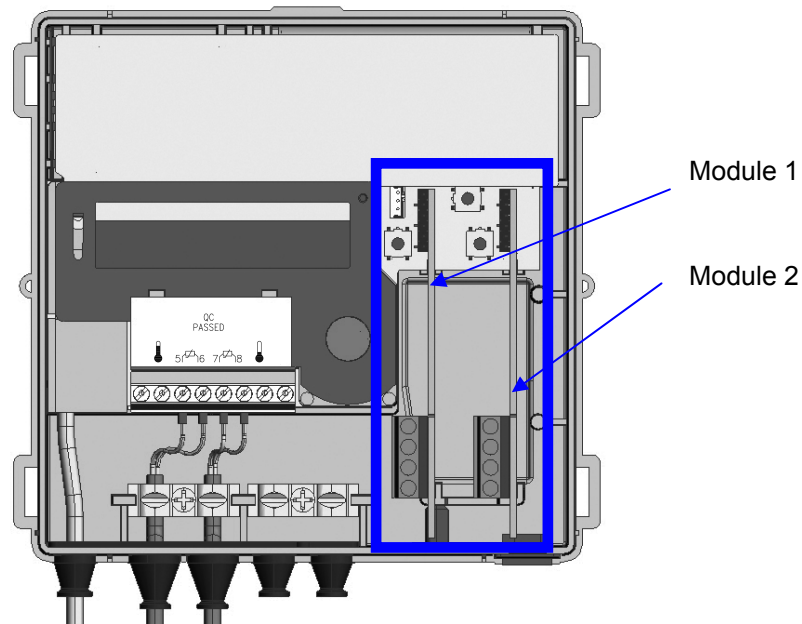

The UH50.. meters are equipped with an optical interface as standard. Also, up to 2 of the following **communication modules** can be used for remote readout:

- Pulse module WZU-P2/WZU-P2L
- CL module WZU-CL
- M-bus module WZU-MB, WZU-MB-G4
- M-bus module with 2 pulse inputs WZU-MI
- Analog module WZU-AM
- RF module, 433 MHz WZU-RM, WZU-RM-EXT
- RF module, 868 MHz WZU-RF, WZU-RF-EXT
- GPRS module WZU-GPRS, WZU-GPRS-ANT
- GSM module WZU-GM

These modules have no impact on consumption metering and can therefore be **replaced at any time without having to destroy the security seal.**

Within 30 seconds after mounting (in case of the analog module up to 2 minutes), the meter detects automatically the module used and is then ready for communication or for delivering pulses.

The type of module used can be displayed within the service loop (loop 4), depending on the parameter settings made for the display.

Permissible combinations of modules

		Socket for module 2 is equipped with...										
		AM (5)	Pulse module		MB	MB G4	MB MI ***)	CL	GPRS	GSM	RM /RF	
			"Standard"	"schnell" *)								
Socket for module 1 can be equipped with...	AM	yes	yes	yes	yes (4)	yes	yes	yes	no	no	yes	
	Pulse modules **)	"standard"	yes	yes (3)	yes (2)	yes (4)	yes	yes	yes	yes	yes	yes
		"fast"	no	no	no	no	no	no	no	no	no	no
	MB	yes	yes	yes	yes (4)	yes	yes	yes (1)	yes	yes	yes	
	MB G4	yes	yes	yes	yes	yes	yes	yes (1)	yes	yes	yes	
	MB MI	yes	yes	yes	yes	yes	yes	yes (1)	no	no	yes	
	CL	yes	yes	yes	yes (1)	yes (1)	yes (1)	no	yes	yes	yes	
	GPRS	no	no	no	no	no	no	no	no	no	no	
	GSM	no	no	no	no	no	no	no	no	no	no	
	RM / RF	no	no	no	no	no	no	no	no	no	no	

Restrictions:

*) Only 1 module with fast pulses is possible; only permissible in socket 2;
min. pulse duration :

- 2 ms, if pulse module 1 is not fitted
- 5 ms, if pulse module 1 is fitted

***) Subsequent mounting of a further pulse module in module socket 1 can result in changed output values for module 2!

***) Not possible with power pack (battery-powered)

- (1) For M-bus with fast readout, CL readout can take up to 40 seconds
- (2) Pulse length of the fast pulses min. 5 ms
- (3) The first and second channel can be parameterized individually
- (4) The secondary address for both modules can only be changed via module no. 1
- (5) Analog module not possible

Terminals

Multipolar connection terminals are used to connect external cables to the modules.

Choice of connections:

- Solid or stranded wire 0.2...2.5 mm²
- Stranded wire with ferrule 0.25...1.5 mm²
- Cable sizes 26 - 14 AWG

Multiline connection (2 lines of same cross-sectional area)

- Solid or stranded wire 0.2...0.75 mm²
- Stranded wire with ferrule without plastic sleeve 0.25...0.34 mm²
- Stranded wire with TWIN ferrule and plastic sleeve 0.5...0.75 mm²

Recommended screwdriver 0.6 x 3.5 mm

Tightening torque 0.4 Nm

The outer diameter of the cable must be between 4 mm and 6 mm. All cables must enter through the meters' bushings. It may be convenient to connect the cables before the meter in a single multi-conductor cable on a split box.

If a shielded cable is used, the shield must not be connected to the side of the meter (connect to one end only).

Pulse modules WZU-P2/WZU-P2L

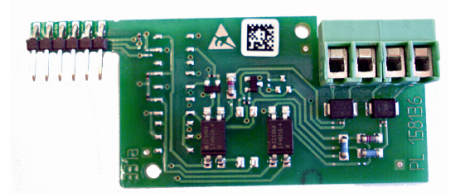

Function data

The pulse modules (WZU-P2 and WZU-P2L) enable the meter to communicate with a pulse collector to transmit measured values. It permits the output of pulses that can be derived from the quantity of heat, volume, tariff register 1 or tariff register 2. Two channels are available whose functions can be parameterized with the service software.

The outputs are in the form of standard pulses or "fast pulses". The pulse duration is identical for channel 1 and channel 2.

Note

The modules can be plugged into both sockets, but fast pulses can only be output via socket 2.

The pulse modules are available in 2 different versions:

WZU-P2 Pulse module with 2 channels to output standard or "definable" pulses

WZU-P2L Pulse module with **opto MOS output**, low voltage drop and reversed polarity protection

Standard pulses

Standard pulse valencies

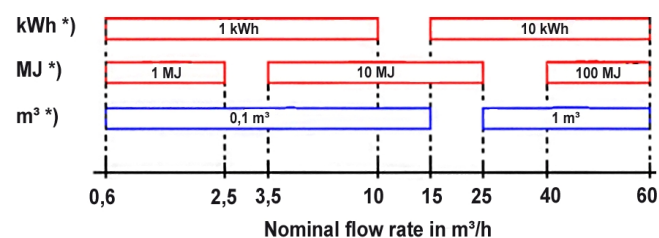

*) depending on the unit for heat display

Pulses for energy, volume, and tariff register

Period duration >200 ms
Pulse duration 100 ms conducting

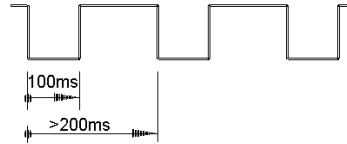

Pulses for operating states

"Ready" pulsed "conducting", i.e. 0.1...0.25 ms pulse duration, 500 ms period
"Fault" constantly "non-conducting"



Fast pulses

Applications, such as controllers or flow measuring sections, require higher pulse rates. The parameters required for this purpose (pulse valency, pulse duration), can be configured via the service software. The maximum pulse frequency is 33 Hz.

Note

When battery-powered, a D-cell is required!

Following can be set:

- Pulse type: "linear" or "scaled" pulses
- Pulse output: Energy or volume
- Pulse duration, if only 1 pulse module is fitted:
 - From 2 ms to 100 ms in increments of 1 ms
- Pulse duration, if 2 pulse modules are fitted:
 - From 5 ms to 100 ms in increments of 5 ms

A suitable device can be used to receive and evaluate the pulses. The settings must be made in accordance with the controller's Data Sheet. Linear pulses are output proportionally to the measured value. In the case of scaled pulses, the number of pulses at the upper and lower end of the range can be defined. In this case, the pulse receiving device can detect a wiring error, for example.

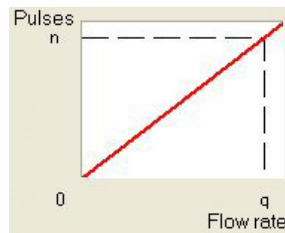

Linear pulses

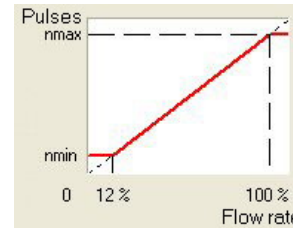

Scaled pulses (example)

LCD

Connection of outputs
(standard version):

CE, C2, CV, CT or RI

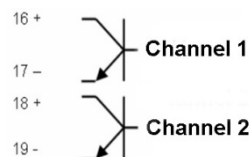

CL module WZU-CL

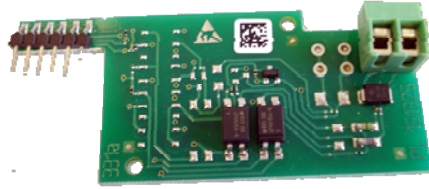

Function data

The CL module (WZU-CL) can be used to set up a point-to-point link, enabling the meter to be read from a remote location (e.g. from the front door).

Note

The CL module can be plugged into any of the 2 sockets. The meter can accommodate only 1 CL module.

Data are refreshed each time a readout is made:

Property number, serial number, firmware version, error messages, missing time, operating time, energy, tariff register, volume, mounting location, adjustment values, unit configuration data, measuring range, M-bus addresses, system date, and time of day.

Previous year's values with set day for: Energy, tariff register, volume, maximum power, and missing time.

18 monthly values for: Energy, tariff register, volume, missing time, maximum power, maximum flow rate, maximum flow temperature, maximum return temperature, and actual values for power.

M-bus modules

WZU-MB

WZU-MB-G4

WZU-MI

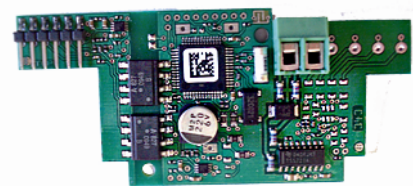
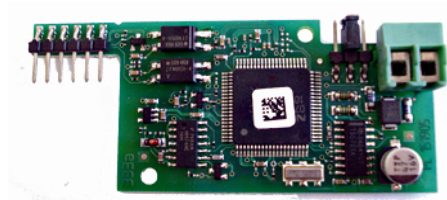

Function data

The M-bus modules (WZU-MB, WZU-MB-G4, and WZU-MI) are used by the meter to communicate with an M-bus central unit to transmit measured values.

For the WZU-MB, the scope of data can be preset with a jumper. With the 2 M-bus modules, the secondary address is identical for both modules. This address can be changed on the meter via the module plugged into socket 1 or via M-bus. The data in the M-bus module are refreshed at 15-minute intervals. Using the UltraAssist software, a shorter sampling cycle can be set on the WZU-MB-G4 and WZU-MI.

The modules are available in 3 different versions:

WZU-MB **M-bus module** for heat and heat/cooling energy meters, generation 2, recommended up to firmware 5.14 as per EN 1434-3

WZU-G4 **M-bus module** for heat and heat/cooling energy meters, generation 4, firmware 5.15 as per EN 13757 and EN 1434-3, and higher from meter firmware 5.17 and module firmware 4.10: NTA standard/ DSMR2.2+ and 3.0

WZU-MI **M-bus module with 2 pulse inputs** for heat and heat/cooling energy meters, generation 4, firmware 5.15 as per EN 13757 and EN 1434-3 and higher from meter firmware 5.17 and module firmware 4.10: NTA standard/ DSMR2.2+ and 3.0

Note

Modules WZU-MB and WZU-MB-G4 can be plugged into any of the 2 sockets. Module WZU-MI must always be plugged into socket 1.

M-bus module WZU-MI with 2 pulse inputs

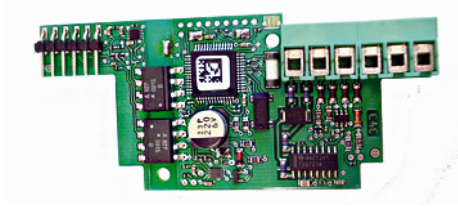

Function data

In addition to the M-bus connection facility, the WZU-MI module has 2 pulse inputs for the connection of metering pulses from hot and cold water meters with Reed contact, relay or open collector. The cumulated volume is calculated based on the pulses and the set pulse valency, stored in the processor unit at 5-minute intervals and passed on via M-bus.

Note

The volume values calculated by the meter from the pulse inputs are not capable of being officially calibrated.

In addition to possible power supply from the M-bus connection, the WZU-MI module is equipped with a battery. It powers the module processor and the pulse input, if no M-bus voltage is applied.

As pulse transmitters for the pulse inputs, either isolated contacts (e.g. relay or Reed contacts) or electronic transmitters (open collectors) can be used.

If an open collector circuit is used as the transmitter of the pulse inputs, the cable must always be electrically isolated from the M-bus inputs of the MI module.

Analog module WZU-AM



Function data

The analog module (WZU-AM) converts the measured value from the heat meter to an analog signal. Each module has 2 channels whose functions can be configured independently.

Parameterization (selection of measured value and output range) is performed with the service software.

The output signal is refreshed at 4-second intervals.

Note

The analog module can be plugged into any of the 2 sockets. Both modules can be used concurrently.

Power supply

The module must be powered via an external power pack (e.g. NZR-NE).

The 2 cables of the power pack are interchangeable.

If 2 analog modules are used, they can be powered by the same power pack. If the meter is mains-powered (AC/DC 24 V), the module(s) and the meter can be connected to the same power outlet. In this case, the wires must be bridged on the module. The connection terminals on the meter's power pack are not suited for that purpose.

If a meter is used with an analog module, a D-cell is required – if battery-powered.

RF module, 433 MHz, WZU-RM

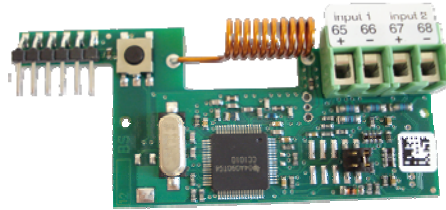

Function data

The RF module (WZU-RM) permits wireless readout from distances of up to 100 meters. The module features 2 additional pulse inputs for counting external metering pulses.

Note

The RF module must be plugged into socket 2 of the meter. Operation with a pulse module in "fast pulses" mode is not allowed.

Power supply

The module is powered via the heat meter. To reduce power consumption, the sampling rate can be extended using a jumper or the transmitter power can be reduced.

If the meter is to be powered by a battery, a D-cell must be used.

Pulse inputs

With regard to the pulse inputs, please note:

- Connect only potentialfree contacts (Reed contacts)
- Inputs and electronics of the meter are not galvanically isolated
- External power supply or earthing is not permitted

Meter ID, pulse valency and the meter readings for the pulse inputs can be predefined by telegram.

Note

In the RF module, the pulses are not multiplied by their pulse valencies. The pulse valencies are merely stored in one register each for information. The assignment is made only when the data read out are evaluated.

RF modules, 868 MHz, WZU-RF/WZU-RF-EXT

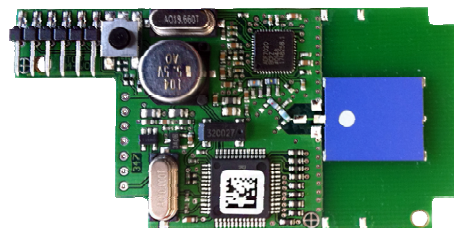

Function data

The RF modules (WZU-RF and WZU-RF-EXT) enable the meter to communicate wirelessly with a center using 868 MHz radio frequency. They support data transmission conforming to OMS and DSMR.

When operating in conformance with DSMR, the meter time can be set. The maximum range is 400 meters.

Note

The module must be plugged into socket 2.

The module is available in 2 different versions:

- WZU-RF Module with internal antenna
- WZU-RF-EXT Module with external antenna

Data output conforming to OMS

The following data are available:

- Current energy
- Current volume
- Current power

- Current flow rate
- Current flow and return temperature
- Error (manufacturer-specific)
- Current time stamp (type I)

Other data telegrams are available on request (e.g. special telegrams for mobile data acquisition).

Power supply

The RF module is powered via the meter. If the meter is to be powered by a battery, a D-cell must be used.

**GPRS module
WZU-GPRS**

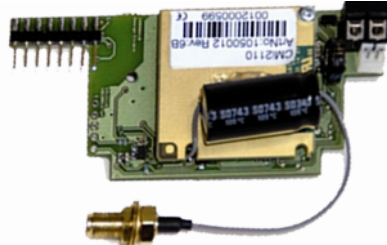

Function data

The WZU-GPRS module is a GSM/GPRS module with M-bus master. The module reads the values of the meter that supports the M-bus protocol and stores the data. It is supplied complete with an external antenna.

Features

- Reading and storing measured values of the heat/cooling energy meter
- Reading and storing measured values of any metering device conforming to the M-bus standard protocol
- Collection of measured values per e-mail, FTP, http, SMS transparent GSM or TCP
- Configurable report templates for manufacturer-specific reports on values, about the system, etc.
- Configurable per SMS, http, or Telenet
- Updating applications, firmware and resources via GPRS remote control

Note

The module must be plugged into socket 2.

M-bus

The module has a built-in M-bus master, capable of reading up to another 8 M-bus meters. If the bus is overloaded, communication problems with the connected slaves occur.

All connected M-bus devices (slaves) must have an unambiguous M-bus secondary address.

Power supply

The module (WZU-GPRS) is supplied complete with the required power supply module (rated voltage AC 100...240 V).

Communication protocols

- E-mail via SMTP with authentication mode HELO, EHLO
- Passive FTP mode with authentication and change of remote directory
- HTTP POST and GET
- GSM data transparent M-bus @ 300 and 2'400 baud and GSM data console TCP Transparent M-bus @300 and 2'400 baud and TCP console
- SMS for configuration
- Internet time synchronization with NTP or daytime protocol

GSM module WZU-GM

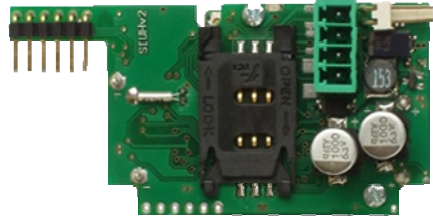

Function data

The WZU-GM is a complementary module used for wireless data transmission in the form of SMS via a GSM network. Messages with data are sent at preconfigured times. When no SMS are sent, the module operates in idle/Eco mode and is separated from the GSM network. It sends 2 types of SMS – service and data messages. The module is programmed via configuration SMS and can be installed either with an internal or external antenna.

Note

The module must be plugged into socket 1.

Pulse inputs

The module is equipped with 2 pulse meters and is galvanically isolated from the meter (pulse inputs I1 and I2 have a common ground). It has its own lithium battery and powers the pulse inputs, in addition to the GSM processor.

The pulse sources used for the respective inputs are either potentialfree contacts (e.g. relay or Reed contacts) or electronic signal sources (e.g. open collector). The pulse valency can be set from 0.01 liters/pulse to 10,000.00 liters/pulse in increments of 0.01 liters/pulse.

The display (only with firmware ≥ 5.15) is made in m3 with 7 digits, depending on the parameter settings made (without or with 1 decimal place).

Note

When using the open collector circuit, the polarity of the inputs must be observed.

Tariff control

Note

The following options are available for tariff control.

The summation of energy and volume in the standard registers is performed independently of the tariff situation!

Threshold value tariff (tariffs T2, 3, 4, 5, 6)

Tariff registers 1, 2 and 3 can be controlled via up to 3 threshold values.

Either energy or volume can be summated in the tariff registers.

The threshold values can be derived from the flow rate (tariff T2), the power (tariff T3), the return temperature (tariff T4), the flow temperature (tariff T5), or the temperature differential (tariff T6).

Supplied quantity of energy (tariff T7)

In tariff register 1, the energy calculated from the flow temperature is summated (and not from the temperature differential).

Returned quantity of energy (tariff T8)

In tariff register 1, the energy calculated from the return temperature is summated (and not from the temperature differential).

Heat/cooling energy meter (tariff T9)

In tariff register 1, the measured cooling energy is summated, in tariff register 2, the measured thermal energy. In both cases, a threshold can be defined via the flow temperature (cold threshold, heat threshold).

Temperature above heat threshold and temperature differential $>+0.2$ K
 \Rightarrow thermal energy is acquired

Temperature below "cold threshold" and temperature differential <-0.2 K
 \Rightarrow cooling energy is acquired

Tariff control via time switch (tariff T10)

For tariff control, one switch-off time and one switch-on time per day can be defined. At the switch-on time, the summation of energy or volume is started in tariff register 1. At the switch-off time, it is ended.

Tariff control via M-bus (tariff T11)

In tariff registers 1, 2 and 3, either energy or volume can be summated. With the relevant M-bus command, one of the 3 tariffs can be activated or all tariffs can be deactivated.

Surcharge quantity tariff by means of return temperature (tariff T12)

The energy is summated depending on the return temperature in tariff registers 1 or 2.

The summated energy is calculated from the temperature differential of return and defined return threshold (and not from the temperature differential).

Above return threshold: T1 is summated.

Below return threshold: T2 is summated.

Display of tariff situation on the LCD

The current tariff state is shown in the user loop together with the energy or the volume.

No tariff state is shown for tariffs T7 and T8.

For tariffs T2, T3, T4, T5, T6, T10, T11, and T12:

— 1234567 kWh	No tariff register active
≡ 1234567 kWh	Tariff register 1 active
⋮ 1234567 kWh	Tariff register 2 active
≡ 1234567 kWh	Tariff register 3 active

For tariff T9 (cooling energy/heat meter)

≡ 1234567 kWh	No tariff register active
— 1234567 kWh	Tariff register 1 active
⋮ 1234567 kWh	Tariff register 2 active

The type of tariff and the associated parameters are displayed in service loop 4.

T2 0000 m/h	For T2, T3, T4, T5, and T6
' 0000 m/h	At 2-second intervals with threshold value 1/2/3
T7 0 °C	For T7
T8 0 °C	For T8
T9c 18 °C	For T9
T9h 45 °C	At 2-second intervals
T10 -----	For T10
T1 0000 0	Switching times at 2-second intervals
T2 1200 1	
T11 -----	For T11
T12 50 °C	For T12

The contents of the tariff registers is displayed in the user loop after the energy.

For tariffs T2, T3, T4, T5, T6, T10, T11, and T12

T' 1234567 kWh	Tariff register 1
----------------	-------------------

T ¹ 1234567 kWh	Tariff register 2
T ³ 1234567 kWh	Tariff register 3 (not for T12)
T ⁷ 1234567 kWh	For tariff T7
T ⁸ 1234567 kWh	For tariff T8
T ⁹ 1234567 kWh	For tariff T9

Log functions

In the internal logbook, metrologically relevant events (errors, states, actions) are stored in chronological order with their time of occurrence. The acquired events are predefined. Logbook data cannot be deleted.

Each event is stored in a separate 4-level shift register. The overflows are transferred to a 25-level circulating buffer. This way, at least the last 4 times can be traced for each event.

In a monthly register, the error states are stored for the current month and the past 18 months (without time stamp).

Serial No.	Description
1	F0 = air in measuring tube
2	F1 = interruption flow temperature sensor
3	F2 = interruption return temperature sensor
4	F3 = error temperature electronics
5	F5 = short-circuit flow temperature sensor
6	F6 = short-circuit return temperature sensor
7	F8 = sensor error > 8 hours
8	F9 = ASIC error
9	Above max. temperature in the flow measuring section
10	Below min. temperature in the flow measuring section
11	Max. flow rate qs exceeded
12	Soiling prewarning
13	Mains voltage off
14	CRC error occurred
15	Adjustment values parameterized
16	F7-(EEPROM) prewarning
17	Reset made
18	Date/time of day parameterized
19	Yearly set day parameterized
20	Monthly set day parameterized
21	Master reset performed
22	All times deleted
23	Missing time deleted
24	Maxima deleted

Readout is performed via the optical interface with the service software.

The data logger (optional) permits archiving of data that the user can select from a predefined set of values. The data logger contains 4 archives whose 8 channels can be assigned. The data can be assigned to any of the channels. Parameterization is performed with the service software.

Archive	Time base	Storage depth	Averaging time for maximum
Hourly archive	1 hour	45 days	1 hour
Daily archive	1 day	65 days	1 hour
Monthly archive	1 month	15 months	1 hour
Yearly archive	1 year	15 years	1 hour/24 hours

*) For measuring periods below 1 hour, the largest value from the maximum values calculated within 1 hour applies

The data are recorded with their values and time stamps. Parameterization and readout are performed via the optical interface with the service software.

Note

Data transmission is in a manufacturer-specific format.

	Value set for data to be recorded
Meter readings at the end of the period for...	Energy Tariff register 1, 2, 3 Volume Operating time *) Fault duration *) Pulse input 1 Pulse input 2 *) Depending on parameter setting: Hours or days
Instantaneous values at the end of the period for...	Power Flow rate Flow temperature Return temperature Temperature differential Error display
Maximum for...	Power Flow rate Flow temperature Return temperature Temperature differential

Maintenance notes

Maintenance

The meters are maintenance-free.
National calibration regulations must be observed.

Disposal



In terms of disposal, the meters and partner devices are classified as electronic scrap conforming to the European Directive 2002/96/EU (WEE) and must not be disposed of as domestic waste. The relevant national legal regulations must be complied with and the devices must be disposed of through the appropriate channels. Local and currently valid legislation must be observed. Exhausted batteries must be disposed of at the specified collection points.

Warranty service

Application-related technical data are only guaranteed together with the products mentioned in this Data Sheet.

If the meters are used in connection with third-party devices that are not explicitly mentioned, the user must ensure proper functioning. In that case, Siemens will not provide any services and warranty.

Technical data

Processor unit

Function data	Measuring range (national approvals may differ)	2...180 °C
	Range of temperature differential $\Delta\Theta$	3...120 K
	Temperature response threshold	0.2 K
	Thermal coefficient	Shifting compensated
	Temperature-measuring error without sensor	$(0,5 + \Delta\Theta_{\min}/\Delta\Theta)$ %, Max. 1.5% at $\Delta\Theta = 3$ K
Temperature sensor	Sensing element	Pt500 as per EN 60751
	Temperature range	0...150 °C (up to 45 mm mounting length) 0...180 °C (from 100 mm mounting length)
Optical interface	Design	Similar to EN 62056-21
	Protocol	As per EN 62056-21
Cable length	Control cable	1.5 m 3.0 m
	Dimensions	DS M10x1 mm, sensor length 27.5 mm DS M10x1 mm , sensor length 38 mm Pocket short \varnothing 5.2x45 mm Pocket long \varnothing 6x100 mm Pocket long \varnothing 6x150 mm

Flow measuring section

Function data	Temperature range (national approvals may differ)	5...130 °C
	Recommended temperature range	
	- Thermal energy	10...130 °C
	- Cooling energy	5...50 °C
	Max. temperature (for 2,000 hours)	150 °C
Rated pressure	1.6 MPa (PN 16)/2.5 MPa (PN 25)	

Mounting position

Optional

Mounting location

Return or flow

Nominal flow rate q_p	Overall length	Connection	Maximum flow rate q_s	Minimum flow rate q_i	Response threshold (variable)	Pressure drop at q_p	Kv flow rate at Δp 1 bar	Kv flow rate at Δp 100 mbar	Weight		
m^3/h	mm	G/DN	m^3/h	l/h	l/h	mbar	m^3/h	m^3/h	kg		
0.6	110	G $3/4$	1.2	6	2.4	150	1.5	0.5	1		
	190	G1							1.5		
		DN20							3		
1.5	110	G $3/4$	3	15	6	150	3.9	1.2	1		
	130	G 1							160	3.8	1.5
	190										
2.5	130	G1	5	25	10	200	5.6	1.8	1.5		
	190					DN20	220	5.3	1.7	3	
3.5	260	G 1 $1/4$	7	35	14	60	14	4.5	3		
		DN25							5		
6	150	G 1 $1/4$	12	60	24	240	12	3.9	3		
	260					DN25	180	14	4.5	5	
10	200	G 2	20	100	40	130	28	8.8	2.6		
						110	30	9.5	4		
	300	DN40				130	28	8.8	7		
15	200	DN50	30	150	60	95	49	15.4	5		
	270					110	45	14.3	8		
25	300	DN65	50	250	100	105	77	24.4	11		
40	300	DN80	80	400	160	160	100	31.6	13		
60	360	DN100	120	600	240	115	177	56	22		

Tolerance in the event of pressure drop: +/- 5%

Power supply optional

Standard battery WZU-BA+GUM	Standard battery	
	- Battery type	2 AA lithium batteries (Li-SOCI2)
	- Battery voltage	3.6 V
	- Battery life	Up to 6 years
- Universal battery WZU-BDS	Universal battery	
	Battery type	1 D-cell lithium battery (Li-SOCI2)
	Battery voltage	3.6 V
	Battery life	6...16 years (depending on configuration)
- Power pack AC 230 V WZU-AC230-15 WZU-AC230-50 WZU-AC230-100	Power pack AC 230 V	
	- Safety class	II
	- Voltage range	AC 196...253 V
	- Frequency	50/60 Hz
	- Max. power consumption	0.8 VA
	- Overvoltage category II as per EN 61010-1	2,500 V surge voltage
	- Length of connecting cable	1.5 m/5 m/10 m
	- External fusing of supply line	Automatic cutout 6 A
	- Backup in the event of a power failure	>20 minutes
- Power pack AC/DC 24 V WZU-ACDC24-00	Power pack AC/DC 24 V	
	- Safety class	III (SELV)
	- Voltage range	AC 12...36 V or DC 12...42 V
	- Frequency	50/60 Hz or DC
	- Max. power consumption	0.8 VA
	- Terminals	2x1.5 mm ² ,
	- For connecting line	Ø 5.0...6.0 mm
	- Backup in the event of a power failure	>20 minutes

Communication

- Pulse module WZU-P2/WZU-P2L	Pulse outputs	
	- Number of outputs per module	2
	- Standard pulses	For energy, volume and tariff register
	- Pulse valencies	1 kWh, 10 kWh, 1 MJ, 10 MJ, 100 MJ, 0.1 m ³ , 1 m ³ per pulse
	- Pulse duration	100 ms conducting
	- Period duration	>200 ms
	- Pulse for operating states	
	- Pulse duration for "Ready"	0.1...0.25 ms conducting
	- Pulse duration for "Fault"	Constantly non-conducting
	- Period duration	500 ms
	- Fast pulses	If 1 pulse module is fitted
	- Pulse duration	2...100 ms in increments of 1 ms
	- Max. pulse frequency	33 Hz
	- Fast pulses	If 2 pulse modules are fitted
	- Pulse duration	5...100 ms in increments of 5 ms
	- Max. pulse frequency	33 Hz

	- Type	Open collector
	- Voltage	Max. DC 30 V
	- Current	Max. 30 mA
	- Classification as per EN 1434-2	OB
	- Voltage drop	Approx. 1.3 V at 20 mA
	- Classification as per EN 1434-2	OC
	- Voltage drop	Approx. 0.3 V at 0.1 mA
	Dielectric strength	500 V _{eff} against ground
- CL module WZU-CL	Passive current loop	As per EN 62056-21 mode B
	- Voltage	Max. DC 30 V
	- Current	Max. 30 mA
	- Voltage drop	<2 V at 20 mA
	- Baud rate	2400 baud, fixed
	- Galvanic isolation	Yes
	- Polarity	Yes
- M-bus modules WZU-MB/WZU-MB G4 WZU-MI	M-bus slave interface	As per EN 1434-3 and EN 13757-2 /-3
	- Voltage	Max. DC 50 V
	- Current draw	1 M-bus load (1.5 mA)
	- Addressing	Primary or secondary
	- Baud rate	300, 1200, 2400, 4800, 9600 baud
	- Polarity	Optional
	- Galvanic isolation	
	- From meter	Yes
	- From pulse inputs	No
- M-bus module WZU-MI Part of pulse input	Pulse inputs	As per EN 1434-2, class IB
	- Number of inputs	2
	- Module battery	
	- Battery type	1 BR2477A (LiCF)
	- Battery voltage	3 V
	- Battery life	In operation: Up to 5 years Storage time: +1 year; if M-bus voltage is fed to the module for at least 90% of the operating time, battery life is extended to 10 years
	- Pulse duration (Low)	≥50 ms
	- Pulse duration (High)	≥50 ms
	- Frequency	Max. 10 Hz
	- Polarity	Yes
	- Galvanic isolation	
	- From meter	Yes
	- From M-bus inputs	No
	- Pulse valency	0.01 to 10,000.00 liters per pulse, in increments of 0.01 liters per pulse
	- Display	In m ³ , 7 digits, without or with 1 decimal place, depending on parameter setting
	- Output voltage	Approx. 3.3 V
	- Internal resistance	Approx. 1 MΩ
	- Source current	Approx. 3 μA

	<ul style="list-style-type: none"> - Pulse input closed (Low) <ul style="list-style-type: none"> - Switching threshold low - Resistance - Pulse input open (High) <ul style="list-style-type: none"> - Switching threshold high - Resistance - Max. cable length 	<ul style="list-style-type: none"> <0.2 V <50 kΩ Collector not fully activated ≥6 MΩ 10 m
- Analog module WZU-AM	<p>Analog output</p> <ul style="list-style-type: none"> - Number of outputs - Output variable - Max. load at current output - Max. load at voltage output - Accuracy - Max. cable length - Cross-sectional area - Outputs short-circuit-proof - Galvanic isolation from meter - External power supply <ul style="list-style-type: none"> - Voltage range - Current draw - Power consumption 	<ul style="list-style-type: none"> 2 Current or voltage configurable 300 Ω 2 kΩ ≤ ± 1% of parameterized max. value 100 m Max. 1.5 mm² Yes Yes AC 12...20 V or DC 12...42 V Max. 170 mA at 12 V Max. 2 VA
- RF module, 433 MHz, WZU-RM	<p>Radio interface</p> <ul style="list-style-type: none"> - Frequency - Transmitter power - Antenna - Readout frequency - Sampling rate (RF) - RF protocol - RF range 	<ul style="list-style-type: none"> 433 MHz 8 mW, can be changed to 5 mW with jumper Built-in Max. 1 readout per day (average) 8 s, can be changed with jumper Proprietary Up to 100 m
- RF module WZU-RM Pulse inputs	<p>Pulse inputs</p> <ul style="list-style-type: none"> - Number of inputs - Pulse duration (Low) - Pulse duration (High) - Frequency <ul style="list-style-type: none"> Max. 10 Hz when using 1 input Max. 5 Hz when using both inputs - Polarity - Galvanic isolation from meter - Pulse valencies - Metering range - Meter ID - Output voltage - Internal resistance - Source current - Pulse input closed (Low) <ul style="list-style-type: none"> - Switching threshold low - Resistance - Pulse input open (High) 	<ul style="list-style-type: none"> As per EN 1434-2, class IB 2 ≥50 ms ≥50 ms Max. 10 Hz when using 1 input Max. 5 Hz when using both inputs Yes No 0.001... 999.999 per pulse input 0...99,999.999 (8 digits) 8 digits for each pulse input 3 V 0.3 MΩ 10 μA 0.5 V 50 kΩ

	- Switching threshold high	2 V
	- Resistance	2 MΩ
	- Max. cable length	10 m
- RF module, 868 MHz, WZU-RF / WZU-RF-EXT	RF interface	As per EN 13757-2/ -4
	- Frequency	868.95 MHz
	- Transmitter power	3.16...25 mW
	- Receive frequency	868.30 MHz
	- Antenna	WZU-RF: Built-in WZU-RF-EXT: External
	- RF protocol	OMS-/DSMR-compliant data transmission
	- RF range	Max. 400 m/typically 30 m in buildings
- GPRS module WZU-GPRS	GPRS interface	Class 12
	- Band	850/900/1,800/1,900 MHz
	- External antenna	WZU-GPRS with magnetic base WZU-GPRS-ANT with screwed connection
	- Protocols	E-mail via SMTP Passive FTP mode HTTP POST and GET GMS data transparent M-bus TCP transparent M-bus
	- Configuration	SMS, HTTP, FTP, GSM CSD
	- Data storage	1.3 MByte
	- Backup real-time clock	3 days
	- Max. humidity in operation	80% r.h.
	- Power supply	Enclosed to the module
	- Voltage range	AC 100...230 V, -20%...+15%
	- Frequency	50/60 Hz
	- Power consumption	Max. 2.5 VA
	- Nominal consumption	Max. 1 VA
	- Overvoltage category as per EN 61010-1	II
- GPRS module WZU-GPRS M-bus master	M-bus master interface	As per EN 13757
	- Baud rate	300 and 2400 baud
	- Number of M-bus slaves	Max. 8
	- Cable length	Max. 1000
	- Connection	2-wire connection, interchangeable
- GSM module WZU-GSM	GSM interface	
	- Band	900/1,800/1,900 MHz
	- Antenna	Built-in or external (optional)
	- Transmitter power	Max. 2 W at 800 MHz Max. 1 W at 1,800 or 1,900 MHz
	- Range	Depending on availability of GMS network
	- Module battery	
	- Battery type	2 AA lithium batteries (Li-SOCI2)
	- Battery voltage	3.6 V
	- Battery life	Approx. 1,600 SMS or 6 years (depending on strength of GSM signal)
	- SMS	Forwarding service and data messages

- GSM module
WZU-GMS
Pulse input section

Pulse inputs	As per EN 1434-2, class IB
- Number of inputs	2
- Pulse duration (Low)	≥50 ms
- Pulse duration (High)	≥50 ms
- Frequency	Max. 10 Hz
- Storing the pulse count	Once per hour (FW ≤5.13) in EEPROM
- Polarity	Yes
- Galvanic isolation from meter	Yes
- Pulse valency	0.01 to 10,000.00 liters per pulse, in increments of 0.01 liters per pulse
- Display (only with firmware ≥5.15)	In m ³ , 7 digits, without or with 1 decimal place, depending on parameter setting
- Output voltage	Approx. 3.3 V
- Internal resistance	Approx. 1.5 MΩ
- Source current	Approx. 2 μA
- Pulse input closed (Low)	
- Switching threshold low	<0.2 V
- Resistance	<50 kΩ
- Pulse input open (High)	
- Switching threshold high	Collector not fully activated
- Resistance	≥6 MΩ
- Max. cable length	10 m

Protection of housing	Safety class	II as per EN 61010-1		
	Degree of protection	IP54		
	- Processor unit			
Environmental conditions		Operation	Transport	Storage
		EN 60721-3-3	EN 60721-3-2	EN 60721-3-1
	Climatic conditions	Class A	Class A	Class A
	Temperature	5...55 °C	-20...60 °C	-20...60 °C
	Humidity	<93% r.h. at 25 °C (non-condensing)	<93% r.h. at 25 °C (non-condensing)	<93% r.h. at 25 °C (non-condensing)
	Mechanical conditions	Class M1	Class M1	Class M1
	Max. altitude	Min. 700 hPa, corresponding to max. 2,000 m above sea level		
Directives and standards	Product standard	DIN EN 1434-1 (heat/cooling energy meters)		
	- MID directive	2004/22/EG (European Measuring Instruments Directive) Mechanical class M1 Electromagnetic class E1		
	- Type approval	- As per EN 1434-4 Environment class A Measuring accuracy class 2		
	Conformity, approvals, certification and compatibility			
	CE conformity as per	See document CE2T5324xx		
	C-Tick	See document CE2T5372en_C1		
Environmental compatibility	Environmental Declaration CE1E5372de			
	contains data on environment-compatible product design and assessment (RoHS conformity, materials used, packing, environmental use, and disposal)	ISO 14001 (environment) ISO 9001 (quality)		
		See environmental declaration CE2E5324		
Dimensions	(W x H x D):			
	- Processor unit	143x136x42 mm		
	- Flow measuring section	See "Dimensions"		
Housing material	Cover	PC		
	Bottom section	PC-GF10		
Housing colors	Cover	Front crystal-clear, logo PEs plastic foil, RAL 7035 and RAL 5014		
	Bottom section	RAL 9002		

Dimensions

Dimensions in mm

Processor unit

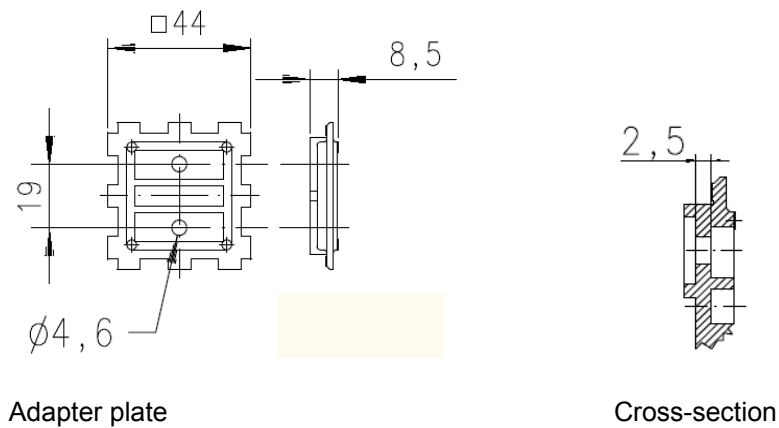
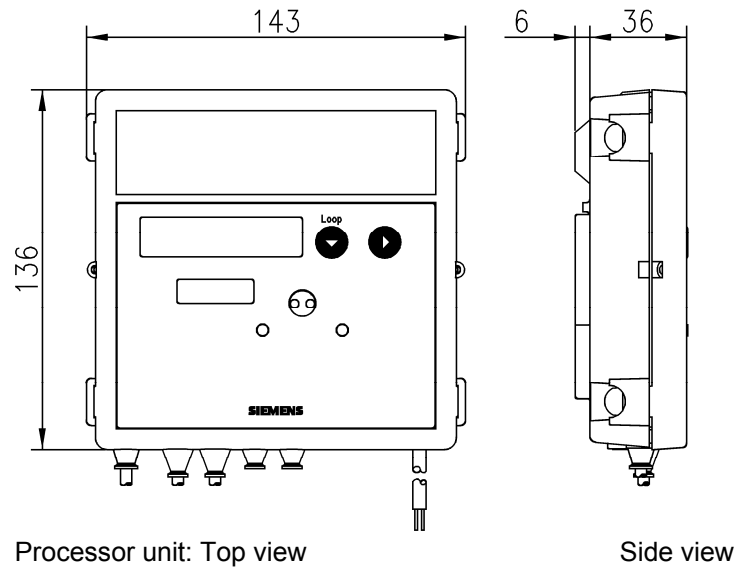

Flow measuring section 0.6...2.5 m³/h

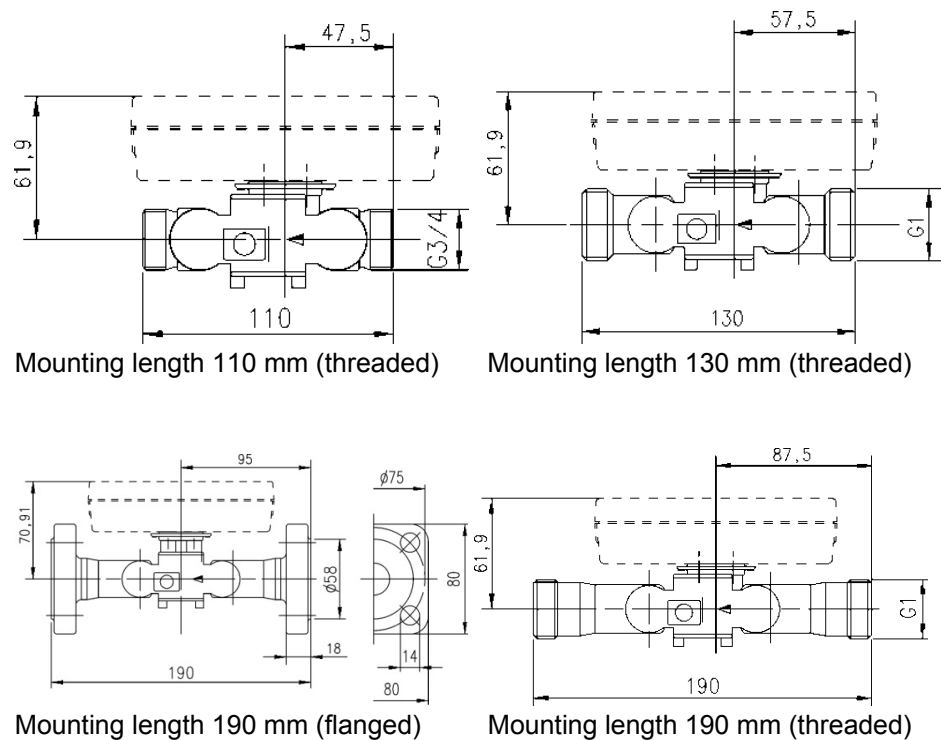

Flow measuring section up to 3.5 m³/h, threaded connections

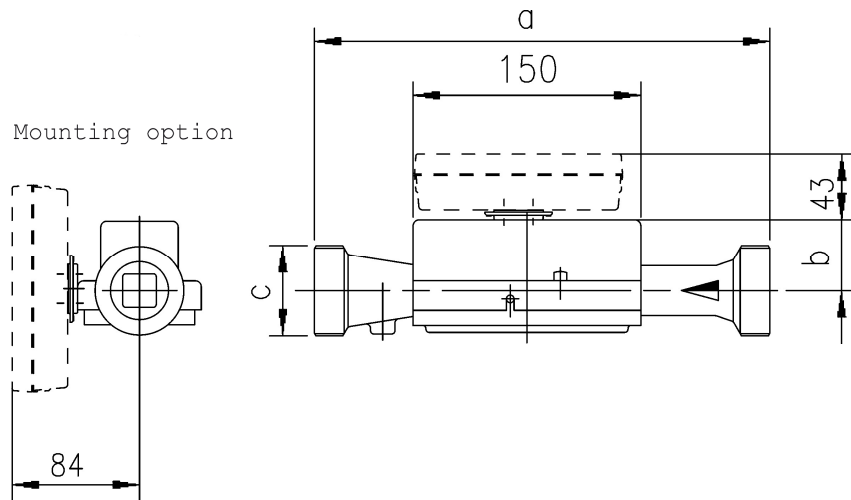

Product no.	qp m ³ /h	PN bar	a	b	c
UH50-x45	3,5	16	260	51	G 1¼
UH50-x47		25			
UH50-x50	6	16	260	51	G 1¼
UH50-x60	10	16	300	48	G 2
UH50-x63		16	200		

Flow measuring section up to 3.5 m³/h, flanged connections

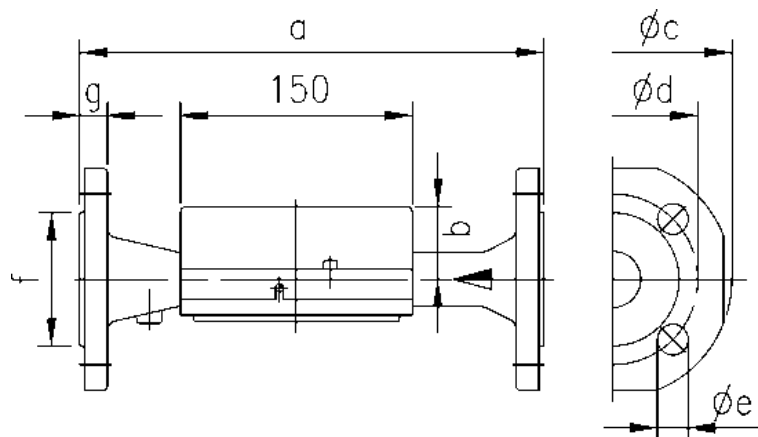

Product no.	qp m ³ /h	PN bar	DN	a	b	Øc	Ød	Øe	No. of holes	f	g
UH50-x46	3,5	25	25	260	51	115	85	14	4	68	18
UH50-x52	6	25	25	260	51	115	85	14	4	68	18
UH50-x61	10	25	40	300	48	150	110	18	4	88	18
UH50-x65	15	25	50	270	46	165	125	18	4	102	20
UH50-x69				200							
UH50-x70	25	25	65	300	52	185	145	18	8	122	22
UH50-x74	40	25	80	300	56	200	160	18	8	138	24
UH50-x82	60	16	100	360	68	235	180	18	8	158	24
UH50-x83	60	25	100	360	68	235	190	22	8	158	24

