

SIEMENS



RVD260 **district heating controller for** **2 heating circuits and d.h.w.** **Basic Documentation**

Edition 1.0
Controller series A
CE1P2515en
17.12.2010

Building Technologies

Siemens Switzerland Ltd
Industry Sector
Building Technologies Division
Gubelstrasse 22
CH 6301 Zug
Tel. +41 41 724 24 24
www.siemens.com/sbt

© 2010 Siemens Switzerland Ltd
Subject to change

Contents

1	Summary	13
1.1	Glossary	13
1.2	Brief description and key features	14
1.3	Type summary	14
1.4	Equipment combinations	15
1.4.1	Suitable sensors	15
1.4.2	Suitable room units	15
1.4.3	Suitable valve actuators	15
1.4.4	Communication	15
1.5	Product documentation	16
2	Use	17
2.1	Types of plant	17
2.2	Types of houses and buildings	17
2.3	Types of heating systems	17
2.4	Heating circuit functions	17
2.5	D.h.w. functions	18
2.6	Extra functions	18
3	Basics	20
3.1	Key technical features	20
3.2	Plant types	20
3.3	Operating modes	23
3.3.1	Heating circuit control	23
3.3.2	D.h.w. heating	23
3.3.3	Manual control	23
4	Acquisition of measured values	24
4.1	General	24
4.2	Flow temperature (B1, B12, B3)	24
4.2.1	Types of sensors	24
4.2.2	Error handling	24
4.3	Outside temperature (B9)	24
4.3.1	Types of sensors	24
4.3.2	Error handling	24
4.4	Room temperature (A6)	25
4.4.1	Types of sensors	25
4.4.2	Error handling	25
4.4.3	Room model	25
4.5	D.h.w. flow temperature (B3)	25
4.5.1	Acquisition of measured value	25

4.5.2	Types of sensors.....	25
4.5.3	Error handling	25
4.6	D.h.w. storage tank temperature (B31, B32)	26
4.6.1	Acquisition of measured value	26
4.6.2	Type of sensor	26
4.6.3	Error handling	26
4.7	D.h.w. return temperature (B32)	26
4.7.1	Acquisition of measured value	26
4.7.2	Type of sensor	26
4.7.3	Error handling	26
4.8	Return temperature (B7, B71, B72)	27
4.8.1	Acquisition of measured value	27
4.8.2	Type of sensor	27
4.8.3	Error handling	27
4.9	Collector temperature (B72).....	27
4.9.1	Type of sensor	27
4.9.2	Error handling	27
4.10	Pressure sensors (U1, U2)	28
4.10.1	Acquisition of measured value	28
4.10.2	Type of sensor	28
4.10.3	Error handling	28
5	Function: Space heating	29
5.1	Operating lines.....	29
5.2	Settings and displays	29
5.3	Heating program	30
6	Function: Setting the clock.....	31
6.1	Operating lines.....	31
6.2	Entries.....	31
7	Function: D.h.w.	32
7.1	Operating lines.....	32
7.2	D.h.w. program	32
7.3	Adjustment of setpoints.....	32
8	Function: Display of sensor values	33
8.1	Operating lines.....	33
8.2	Displays	33
9	Function: Holiday settings.....	34
9.1	Operating lines.....	34
9.2	Holiday program.....	34

10	Function: Display of faults	35
10.1	Operating line	35
10.2	Display of faults	35
11	Function block: Plant configuration.....	36
11.1	Operating lines	36
11.2	Parameter settings	36
11.2.1	Plant type.....	36
11.2.2	Input B71/U1.....	36
11.2.3	Input B7/U2.....	37
11.2.4	Input B72	37
11.2.5	Circulating pump.....	37
11.2.6	Input H5	38
11.2.7	Speed-controlled pump	38
12	Function block: Space heating	42
12.1	Operating lines	42
12.2	Compensating variables	42
12.2.1	Outside temperature.....	42
12.2.2	Room temperature.....	43
12.3	Heating curve	44
12.4	Generation of setpoint	45
12.4.1	Display of setpoint	45
12.4.2	Setpoint for weather-compensated control.....	45
12.4.3	Setpoint for room temperature-compensated control	46
12.4.4	Setpoint for weather-compensated control with room influence.....	47
12.5	Heating period	47
12.6	Heating circuit control	48
12.6.1	Weather-compensated control	48
12.6.2	Room temperature-compensated control	48
12.6.3	Weather-compensated control with room influence	48
12.7	Automatic ECO function	49
12.7.1	Basics	49
12.7.2	Compensating and auxiliary variables.....	49
12.7.3	Heating limit.....	50
12.7.4	Mode of operation of ECO function 1	50
12.7.5	Mode of operation of ECO function 2	50
12.8	Pump overrun	50
12.9	Maximum limitation of room temperature	50
12.10	Optimization.....	51
12.10.1	Definition and purpose.....	51
12.10.2	Basics	51
12.10.3	Process.....	52

12.10.4	Room model temperature	52
12.10.5	Optimum stop control.....	53
12.10.6	Quick setback	53
12.10.7	Optimum start control.....	53
12.10.8	Maximum rate of flow temperature increase.....	54
12.11	Frost protection for the building	54
12.11.1	General	54
12.11.2	Mode of operation with room sensor.....	54
12.11.3	Mode of operation without room sensor.....	55
12.12	Other protection functions.....	55
12.12.1	Pump kick	55
12.12.2	Valve kick.....	55
12.12.3	Shutdown of pump	55
12.12.4	Pump and mixing valve overrun.....	56
13	Function block: Valve actuator heat exchanger	57
13.1	Operating lines.....	57
13.2	Mode of operation	57
13.3	Control process.....	57
13.4	Maximum limitation of flow temperature	57
13.5	Minimum limitation of flow temperature	58
13.6	External heat demand at input H5	58
13.7	External heat demand at input B71/U1	58
14	Function block: Valve actuator space heating	59
14.1	Operating lines.....	59
14.2	Mode of operation	59
14.3	Control process.....	59
14.4	Maximum limitation flow temperature	59
14.5	Minimum limitation of flow temperature	60
15	Function block: D.h.w. heating/legionella function	61
15.1	Operating lines.....	61
15.2	Release of d.h.w. charging	61
15.3	Control of circulating pump	62
15.4	Switching differential of d.h.w. control.....	62
15.5	Legionella function	62
15.5.1	Weekday for legionella function	62
15.5.2	Setpoint for legionella function.....	63
15.6	Priority of d.h.w. charging	63
15.6.1	General	63
15.6.2	Absolute priority	63
15.6.3	Shifting priority	64

15.6.4	No priority	64
15.7	Pump overrun	65
15.7.1	General	65
15.7.2	Intermediate circuit pump	65
15.7.3	Storage tank charging pump	65
15.8	Frost protection for d.h.w.	65
15.9	Switching d.h.w. heating off	65
15.10	D.h.w. heating with storage tanks	66
15.10.1	General	66
15.10.2	D.h.w. charging	67
15.10.3	Maximum charging time	67
15.10.4	Manual storage tank charging	67
15.10.5	Forced charging	68
15.10.6	Protection against discharging	68
15.10.7	Protection against overtemperature	68
15.10.8	Storage tank with electric immersion heater	68
15.11	D.h.w. heating with stratification storage tank	69
15.11.1	General	69
15.11.2	D.h.w. heating	69
15.11.3	Feeding the circulating water into the heat exchanger	69
15.12	Direct d.h.w. heating	70
15.12.1	General	70
15.12.2	D.h.w. heating	70
15.12.3	Protection against cooling down	70
15.12.4	Siting the sensors	71
15.12.5	Flow switch	71
15.12.6	Compensation of heat losses	71
15.12.7	Cold water sensor	72
16	Function block: Valve actuator d.h.w.	73
16.1	Operating lines	73
16.2	Mode of operation	73
16.3	Control process	73
16.4	Setpoint boosts	74
16.4.1	Charging boost	74
16.4.2	Flow temperature boost	74
16.5	Maximum setpoint for d.h.w. temperature	74
16.6	D.h.w. charging with 2 storage tank sensors	74
16.7	Adjustable load limit	75
16.7.1	Adjustment to the season	75
16.7.2	Load limit	75
16.7.3	Child-proofing	76

17	Function block: Assignment of d.h.w.	77
17.1	Operating line.....	77
17.2	Assignment d.h.w. charging.....	77
18	Function block: Extra legionella functions.....	78
18.1	Operating lines.....	78
18.1.1	Legionella function.....	78
18.1.2	Setpoint.....	78
18.1.3	Time.....	78
18.1.4	Dwelling time.....	78
18.1.5	Operation of circulating pump.....	79
18.1.6	Maximum limitation of return temperature.....	79
18.2	Mode of operation.....	79
19	Function block: Multifunctional relays.....	81
19.1	Operating lines.....	81
19.2	Mode of operation and settings.....	81
20	Function block: LPB parameters.....	82
20.1	Operating lines.....	82
20.2	LPB parameters.....	82
20.2.1	Addressing the devices.....	82
20.2.2	Source of time of day.....	82
20.2.3	Bus power supply.....	83
20.2.4	Outside temperature source.....	83
20.3	Locking signals.....	84
20.3.1	Basics.....	84
20.4	Critical locking signals.....	84
20.5	Uncritical locking signals.....	85
20.5.1	General.....	85
20.5.2	Controller-internal uncritical locking signals.....	85
20.5.3	Uncritical locking signals from data bus.....	85
21	Function block: Device functions.....	86
21.1	Operating lines.....	86
21.2	Pulse lock for actuators.....	86
21.3	Frost protection for the plant.....	86
21.3.1	Principle.....	86
21.3.2	Mode of operation with outside sensor.....	86
21.3.3	Mode of operation without outside sensor.....	87
21.3.4	Frost protection for heating circuit flow.....	87
21.4	Flow alarm.....	87
21.4.1	Heating circuit and d.h.w. circuit with storage tanks.....	87

21.4.2	Direct d.h.w. heating via heat exchanger	88
21.5	Changeover winter-/summertime	89
21.6	Pump kick	89
21.7	Speed-controlled pump	89
22	Function block: M-bus parameters	90
22.1	Operating lines	90
22.2	General	90
22.3	Addressing and identification	90
22.4	Baud rate	90
22.5	Load management	90
22.5.1	Load management of d.h.w.	90
22.5.2	Load management of heating system	91
22.5.3	Resetting the load management signals	91
22.5.4	Forwarding signals via LPB	91
22.5.5	Resolution of M-bus signals	91
23	Function block: PPS parameters	92
23.1	Operating lines	92
23.2	Impact of room unit on the heating circuits	92
24	Function block: Test and display	93
24.1	Operating lines	93
24.2	Sensor test	93
24.3	Setpoint test	93
24.4	Relay test	94
24.5	Display of pump speed	94
24.6	Display of digital input	94
24.7	Limitations	95
24.8	Software version	95
25	Function block: Solar d.h.w.	96
25.1	Operating lines	96
25.2	General	96
25.3	Functions	97
25.3.1	Temperature differential ON/OFF solar	97
25.3.2	Minimum charging temperature	97
25.3.3	Minimum running time	98
25.3.4	Frost protection temperature for collector	98
25.3.5	Overtemperature protection for collector	99
25.3.6	Storage tank recooling	99
25.3.7	Evaporation temperature of heat conducting medium	100
25.3.8	Maximum limitation of charging temperature	101

25.3.9	Maximum limitation of storage tank temperature	101
25.3.10	Collector start function	101
26	Function block: Refill functions	103
26.1	Operating lines.....	103
26.2	General	103
26.3	Mode of operation	104
26.3.1	Overview of functions.....	104
26.3.2	Relative secondary minimum pressure.....	104
26.3.3	Refill locking time after shutdown	104
26.3.4	Minimum secondary underpressure period.....	104
26.3.5	Secondary switching differential	104
26.3.6	Function of primary pressure sensor (U2)	105
26.3.7	Maximum refill period per charging cycle.....	105
26.3.8	Maximum refill period per week	105
26.3.9	Configuration of sensors	105
26.3.10	Resetting the counters refill period per charging cycle, per week.....	105
27	Function block: DRT and maximum limitation of return temperature.....	106
27.1	Operating lines.....	106
27.2	Maximum limitation of primary return temperature	106
27.2.1	General	106
27.2.2	Maximum limitation in heating mode.....	107
27.2.3	Maximum limitation in d.h.w. heating mode.....	107
27.3	Maximum limitation of secondary return temperature.....	108
27.4	Maximum limitation of return temperature differential (DRT function)	109
27.4.1	Mode of operation	109
27.4.2	Purpose.....	109
27.5	Integral action time of limit functions.....	109
28	Function block: Miscellaneous	110
28.1	Operating lines.....	110
28.2	Limit function at input H5	110
28.3	Suppression of hydraulic creep.....	111
28.3.1	Mode of operation	111
28.3.2	Mode of operation	111
28.4	Increase of reduced room temperature setpoint.....	111
29	Function block: Operation locking functions	113
29.1	Operating lines.....	113
29.2	Locking settings on the software side.....	113
29.3	Locking of locking functions level on the hardware side.....	113
30	Combination with PPS devices	114

30.1	General.....	114
30.2	Combination with room unit QAW50.....	114
30.2.1	General.....	114
30.2.2	Overriding the operating mode.....	115
30.2.3	Knob for room temperature readjustments.....	115
30.2.4	Controller with operation lock.....	115
30.3	Combination with room unit QAW70.....	115
30.3.1	General.....	115
30.3.2	Overriding the operating mode.....	116
30.3.3	Knob for room temperature readjustments.....	116
30.3.4	Impact of the QAW70 operating lines on the RVD260.....	116
30.3.5	Controller with operation lock.....	117
30.3.6	Entry of holidays.....	117
30.3.7	Freely programmable input.....	117
30.4	Room sensor QAA10.....	118
31	Handling.....	119
31.1	Operation.....	119
31.1.1	General.....	119
31.1.2	Analog operating elements.....	120
31.1.3	Digital operating elements.....	120
31.1.4	Controller in "unoperated state".....	120
31.1.5	Safety concept.....	121
31.1.6	Setting levels and access rights.....	121
31.2	Commissioning.....	122
31.2.1	Installation instructions.....	122
31.2.2	Operating lines.....	122
31.3	Manual control.....	122
32	Engineering.....	124
32.1	Connection terminals.....	124
32.2	Installation.....	125
32.3	Relays.....	125
32.4	PWM output.....	125
32.5	Lightning protection in M-bus plants.....	125
32.6	Connection diagrams.....	126
32.6.1	Low-voltage side.....	126
32.6.2	Mains voltage side.....	126
33	Mechanical design.....	127
33.1	Basic design.....	127
33.2	Mounting.....	127
33.2.1	Mounting location.....	127

33.2.2	Mounting choices	127
33.3	Dimensions	128
34	Addendum.....	129
34.1	Technical data.....	129
34.2	Revision history.....	129
34.3	Index	130

1 Summary

1.1 Glossary

In this Basic Documentation, the following key terms are used (among others):

Heat source, heat generation

<i>Term</i>	<i>Explanation</i>
Heat exchanger	Heat exchanger whose primary side is connected to the district heating network and whose secondary side supplies the heat to a precontrolled or common flow, or directly to the consumers, such as space heating, d.h.w. heating, etc.

Pumps

<i>Term</i>	<i>Explanation</i>
Storage tank charging pump	Pump that supplies tap water via the heat exchanger to the storage tank where it is made available as d.h.w.
Intermediate circuit pump	Pump that supplies water as a heat conducting medium. The water transfers the heat via a coil or storage tank to the d.h.w. without getting in direct contact with it.

D.h.w. heating

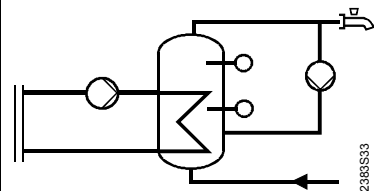
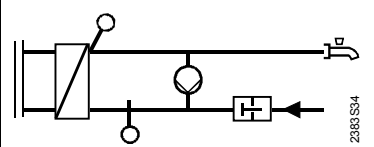
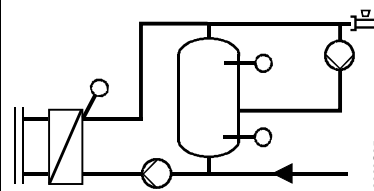
<i>Term</i>	<i>Explanation</i>
Coil type storage tank	
Direct d.h.w. heating (via heat exchanger)	
Stratification storage tank	
Storage tanks	Common term for coil type and stratification storage tanks.

1.2 Brief description and key features

- The RVD260 is a multifunctional heating controller which has been designed to control the flow temperature of 2 heating circuits plus d.h.w. heating
- The controller is used exclusively in plants with district heat connection. It is intended for use in small to medium-size residential and non-residential buildings with 2 heating circuits
- A number of combinations facilitate the configuration of 14 different plant types. The configuration activates all functions and settings required for the respective plant type. Optional functions require extra configurations
- In terms of control, the RVD260 has been designed as a flow temperature controller. Control can be effected as follows:
 - Weather-compensated control of the heating circuit flow temperatures
 - Weather- and room temperature-compensated control of the heating circuit flow temperatures
 - Room temperature-compensated control of the heating circuit flow temperatures
 - Demand-dependent control of the common heating circuit flow temperature
- If the date lies outside the parameterized heating period, the heating circuit is switched off
- The RVD260 supports the refill function, aimed at maintaining the plant pressure on the secondary side
- In terms of d.h.w. heating, the RVD260 has been designed for the following types of applications:
 - With coil type storage tanks
 - With stratification storage tanks
 - Direct d.h.w. heating via heat exchanger
 - With electric immersion heater and solar collector
 - Common or separate heat exchangers for the heating circuit and d.h.w. heating
 - 2-stage separation of d.h.w. and district heating
- The RVD260 is suited for the control of 2-port and 3-port valves and pumps one of which can be a speed-controlled pump.
- For direct adjustment of the nominal room temperature setpoint, 2 setting knobs are used. All other parameters are set digitally based on the operating line principle.
- Key design features: Operating voltage AC 230 V, CE conformity, overall dimensions to IEC 61554 (144 x 96 mm)

1.3 Type summary

The RVD260 is a compact controller and requires no accessories such as inserts, plug-in modules, etc. It is supplied complete with base.

RVD260-A or RVD260-C (language code -A, -C) specifies the language set of the instructions included with the controller.

<i>Product no.</i>	<i>Instructions included in ...</i>
RVD260-A	German, French, English, Italian, Danish, Finnish, Swedish
RVD260-C	Polish, Czech, Greek, Russian, Bulgarian, Romanian

1.4 Equipment combinations

1.4.1 Suitable sensors

- For water temperatures:
Suitable are all types of Siemens sensors using a sensing element LG-Ni1000:
 - Strapon sensor QAD22
 - Immersion sensors QAE212...
 - Immersion sensor QAP21.3 complete with connecting cable
 - Immersion sensor QAP21.2 complete with connecting cable (solar)
- For the room temperature:
Suitable are PPS-compatible sensors:
 - Room sensor QAA10
 - Room units QAW50, QAW50.03 and QAW70
- For the outside temperature:
 - Outside sensor QAC22 (sensing element LG-Ni1000)
 - Outside sensor QAC32 (sensing element NTC 575)
- For pressure:
Suitable are sensors delivering DC 0...10 V signals, such as:
 - Pressure sensors QBE2002...

Note:

The RVD260 controller identifies automatically the connected type of sensor.

1.4.2 Suitable room units

- Room unit QAW50
- Room units QAW50.03 and QAW70 (both addressable)

1.4.3 Suitable valve actuators

All types of actuators from Siemens with the following features can be used:

- Electromotoric or electrohydraulic
- Running times from 10...900 seconds
- 3-position control
- Operating voltage AC 24...230 V

1.4.4 Communication

Communication with other devices and controllers, etc., is possible:

- Via LPB, e.g. assignment of d.h.w., master/slave assignments for the time switch, reception of outside temperature signal
- Via M-bus, e.g. readout of setpoints and actual values, or output control for space heating

1.5 Product documentation

<i>Type of document</i>	<i>Document no.</i>	<i>Stock no.</i>
Data Sheet	N2515	
Installation Instructions Language set: de, en, fr, it, da, fi, sv	G2515	74 319 0726 0
Installation Instructions Language set: pl, cs, el, ru, bg, ro	G2515	74 319 0727 0
Operating Instructions Language set: de, en, fr, it, da, fi, sv	B2515	74 319 0728 0
Operating Instructions Language set: pl, cs, el, ru, bg, ro	B2515	74 319 0729 0
CE Declaration of Conformity	T2513	STEP Web Client
Environmental Declaration	E2513	STEP Web Client
LPB Basic System Data	N2030	STEP Web Client
LPB Basic Engineering Data	N2032	STEP Web Client
M-Bus Basic System Data	N5361	STEP Web Client
M-Bus Planning Manual	J5361	STEP Web Client

2 Use

2.1 Types of plant

The RVD260 is suited for all types of heating plants in houses or buildings...

- connected to a district heating network and operating with 2 heating circuits,
- in which the flow temperature of the heating circuits is controlled either weather- or room temperature-compensated,
- where the control of d.h.w. heating is integrated as an option.

2.2 Types of houses and buildings

The RVD260 is suited for use in all types of houses and buildings in which the heating system is controlled either weather- or room temperature-compensated. The controller has been designed especially for ...

- single-family houses,
- multifamily houses,
- small to medium-size non-residential buildings.

2.3 Types of heating systems

The RVD260 is suited for use with all standard heating systems, such as...

- radiators,
- convectors,
- floor heating systems,
- ceiling heating systems,
- radiant panels.

2.4 Heating circuit functions

The RVD260 is used if 1 or several of the following heating circuit functions is/are required:

- Weather- or room temperature-compensated or weather- and room temperature-compensated flow temperature control
- Separate flow temperature control of both heating circuits
- Modulating flow temperature control via valve
- Common or separate heat exchangers for heating circuit and d.h.w.
- Optimized heating up and setback of room temperature by learning the optimum switch-on and switch-off time
- Quick setback with or without room sensor
- Automatic ECO function: Demand-dependent switching of the heating system as a function of the outside temperature
- 7-day program for the heating periods with up to 3 periods per day and daily varying on times
- Frost protection for the plant and the house or building
- Yearly clock
- Holiday programs
- Independent time programs for space heating and d.h.w. heating
- Separate time switch programs for each heating circuit
- Heating period can be parameterized
- Maximum limitation of rate of flow temperature increase
- Minimum and maximum limitation of flow temperature
- Maximum limitation of room temperature
- Flow alarm

- Reception of heat demand signal
- Limitation of return temperature differential (DRT function)
- Maximum limitation of primary return temperature
- Limitation of output or volumetric flow by pulses
- Suppression of hydraulic creep in the primary circuit
- Weather-compensated raising of the reduced room temperature setpoint
- Remote control via room unit

2.5 D.h.w. functions

The RVD260 is used if 1 or several of the following d.h.w. functions is/are required:

- Common or separate heat exchangers for heating circuit and d.h.w.
- D.h.w. heating with coil type storage tank, with charging pump
- Direct d.h.w. heating via heat exchanger
- D.h.w. heating with coil type or stratification storage tanks, with or without mixing valve in the intermediate circuit
- Modulating control of d.h.w. heating via mixing valve
- Flow switch with adjustable load limit, child-proofing and adaptation to the season
- Specific time program for the release of d.h.w. heating
- D.h.w. heating with electric immersion heater
- D.h.w. heating via solar collector
- Optional assignment of circulating pump to the heating circuit's or the d.h.w. circuit's time program
- Cooling down protection with d.h.w. heating via heat exchanger
- Legionella protection
- Forced d.h.w. charging
- Frost protection for d.h.w.
- Selectable priority for d.h.w. heating: Absolute, shifting or parallel
- Manual d.h.w. charging outside the time program
- Maximum limitation of d.h.w. return temperature
- Flow alarm

2.6 Extra functions

The RVD260 is used if 1 or several of the following functions is/are required:

- Demand-dependent control of the common flow
- Pump kick, periodic pump run
- Pump overrun
- Valve kick, periodic activation of all actuators on the secondary side
- PWM output; 1 of the pumps can be speed-controlled
- Display of parameters, actual values, operating states and error messages
- Remote control via room unit
- Alarm input
- Analog input DC 0...10 V (display, external heat demand)
- Digital input (heat meter, external heat demand, etc.)
- Flow switch (including child-proofing and adaptation to the season)
- Refill function
- Communication via M-bus
- Communication via LPB (Local Process Bus)
- Service functions
- Pulse lock for actuators
- Sensor test
- Relay test
- Display of setpoint
- Display of all active limitations

- Locking settings
- Connection of sensors for display only

3 Basics

3.1 Key technical features

The RVD260 offers 3 key technical features:

- The controller provides a total of 14 preprogrammed plant types. For details, refer to chapter 3.2 "Plant types", which shows the plants in the form of diagrams
- The functions are assigned to 3 setting levels; setting levels "Heating engineer" and "Locking functions" have them summarized as function blocks
- The settings are made via operating lines (see chapter 5 ff.)

<i>Setting level</i>	<i>Function</i>
End-user	Space heating
	Setting the clock
	D.h.w.
	Display of sensor values
	Holiday settings
	Display of faults
	<i>Function block</i>
Heating engineer	Plant configuration
	Space heating
	Valve actuator heat exchanger
	Valve actuator space heating
	D.h.w. heating/legionella function
	Valve actuator d.h.w.
	Assignment of d.h.w.
	Extra legionella functions
	Multifunctional relays
	LPB parameters
	Device functions
	M-bus parameters
	PPS parameters
	Test and display
Solar d.h.w.	
Refill functions	
Locking functions	DRT and maximum limitation of return temperature
	Miscellaneous
	Operation locking functions

3.2 Plant types

The RVD260 allows the configuration of 14 different plant types as combinations of space heating and d.h.w. heating. Each plant type consists of 2 heating circuits and 1 d.h.w. circuit.

When commissioning a plant, the respective plant type must be entered. All required functions, settings and displays are then automatically assigned, and parameters not required will be hidden.

With the available plant types, practically all types of heating plants with district heat connection and own d.h.w. heating can be controlled.

Note:

Optional functions require extra configurations.

Plant types

For B9, Y5, M3, etc., refer to chapter 32.6 "Connection diagrams".
Components shown in broken lines are optional.

Plant types 1 - x

1 - 0

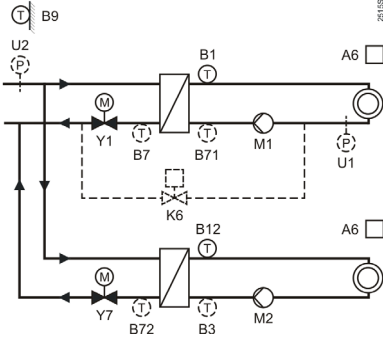

2115801

1 - 3

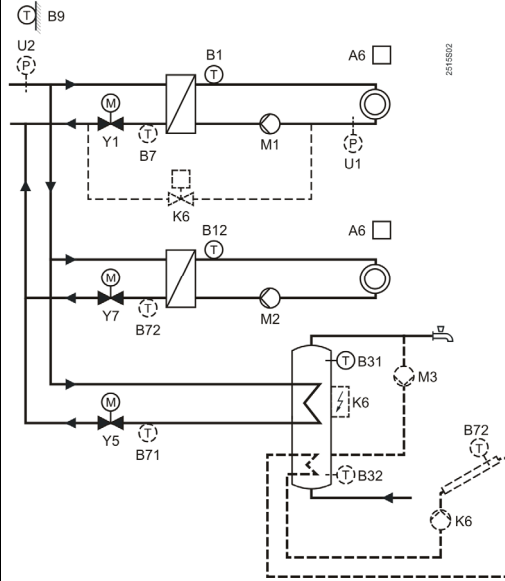

2115802

1 - 4

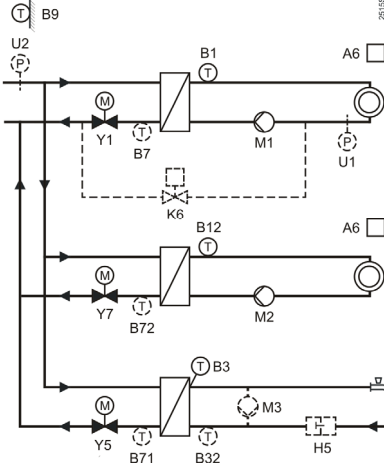

2115803

1 - 8

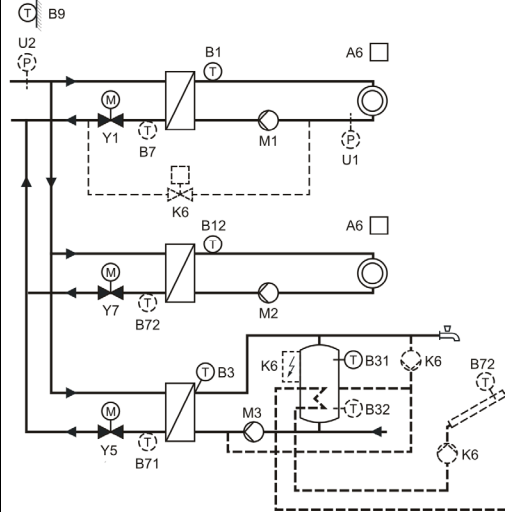

2115804

1 - 9

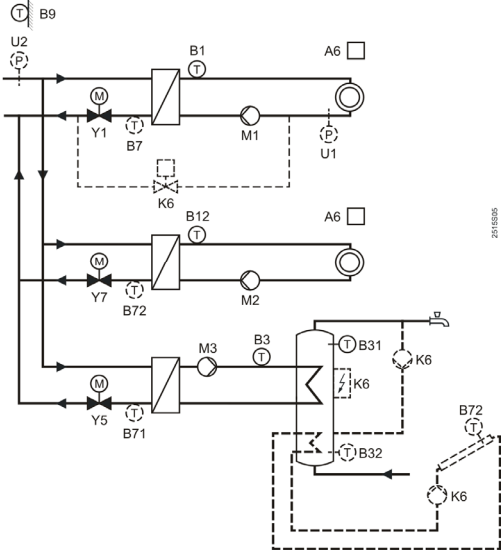

2115805

Plant types 2 - x

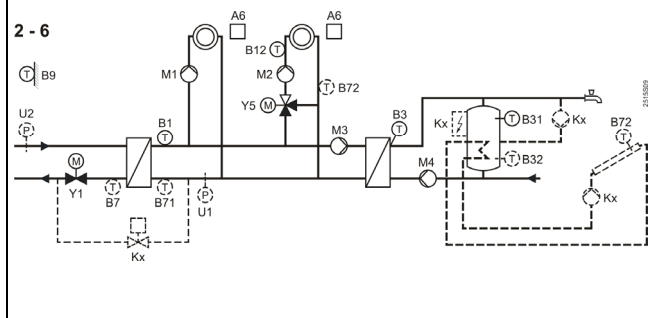
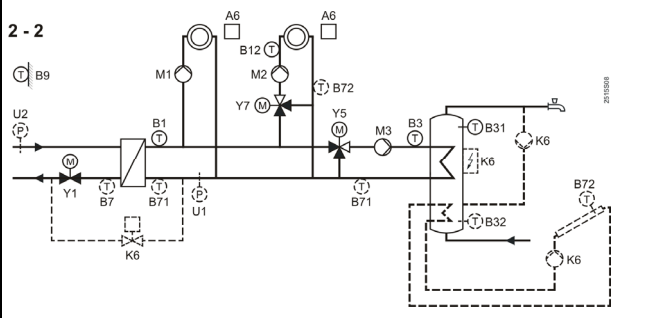
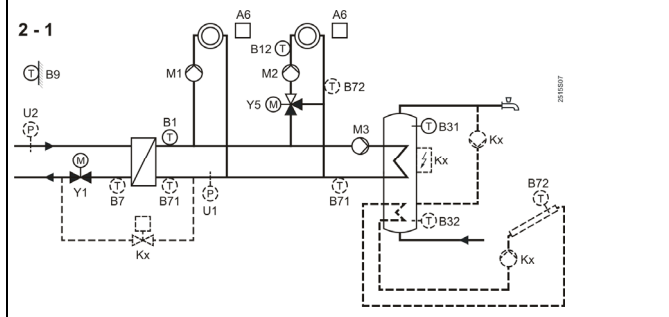
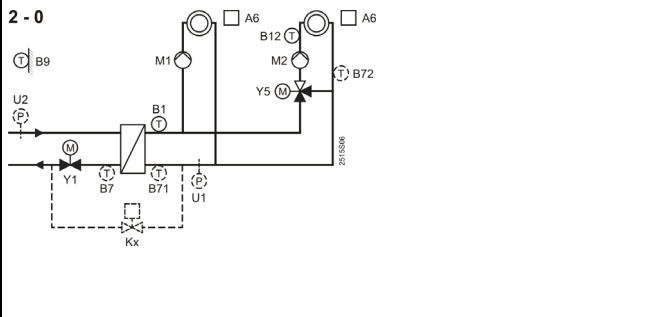

Plant types 3 - x

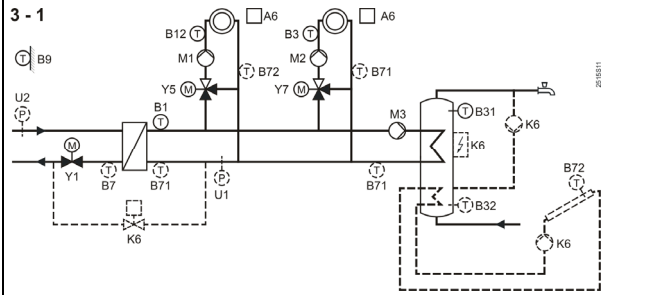
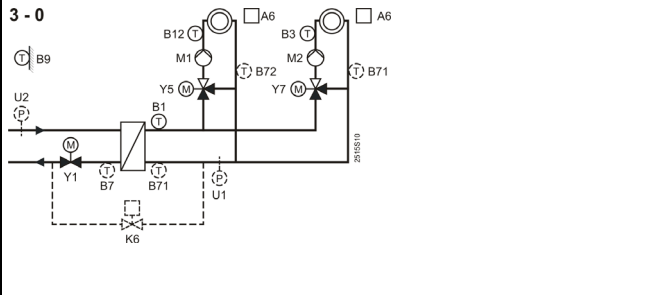

Plant types 4 - x

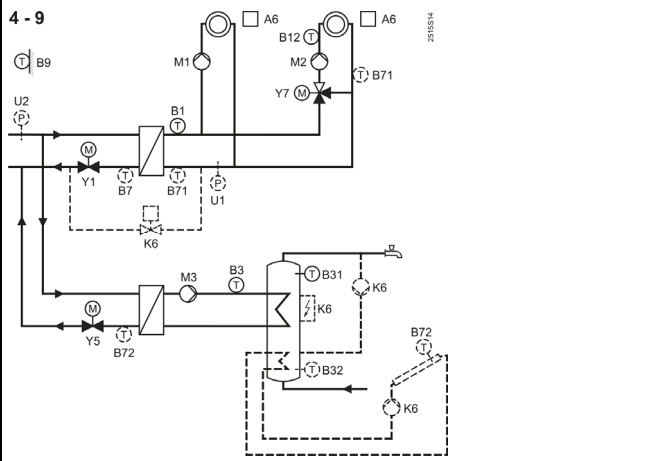
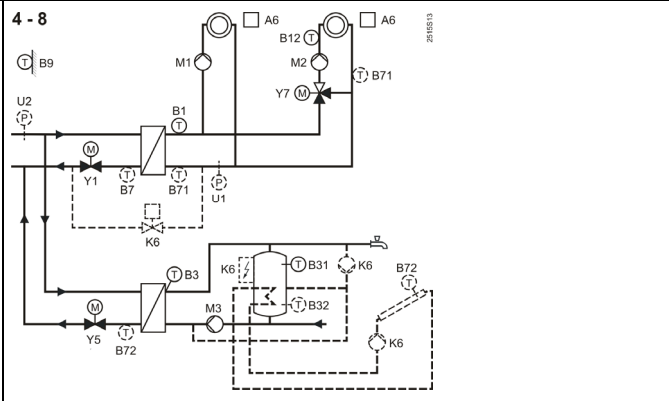
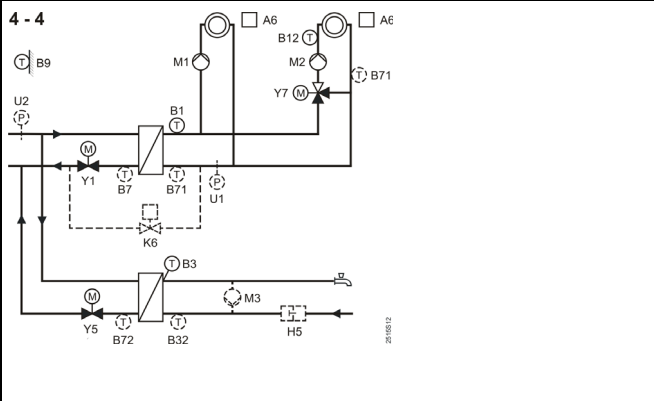

3.3 Operating modes

3.3.1 Heating circuit control

The RVD260 offers the following operating modes:



Automatic operation

- Automatic heating operation, changeover between nominal and reduced room temperature according to the time program
- Demand-dependent switching of heating system as a function of the outside temperature while giving consideration to the building's thermal inertia (automatic ECO function)
- Optional remote control via room unit
- Frost protection is ensured



Continuous operation

- Heating operation without time program
- Heating to the temperature adjusted with the setting knob
- Automatic ECO function not active
- Frost protection is ensured



Protection

- Heating to the frost protection level
- Frost protection is ensured

3.3.2 D.h.w. heating



- ON (button lit): D.h.w. heating takes place independent of the heating circuit's operating mode and control (no d.h.w. heating during holiday periods)
- OFF (button dark): No d.h.w. heating. The circulating pump switches off. Frost protection is ensured

3.3.3 Manual control



- No automatic control
 - Pumps are in operation
 - 2-port valve in the primary circuit can be manually adjusted via setting buttons
- For detailed information, refer to chapter 31.3 "Manual control".

4 Acquisition of measured values

4.1 General

Should a sensor become faulty, the RVD260 tries to maintain the required comfort level. In that case, certain heat losses may occur, without causing any damage. In the event of severe errors, an error message is delivered and the controller displays *Er* (error).

4.2 Flow temperature (B1, B12, B3)

4.2.1 Types of sensors

Suitable are all types of Siemens sensors using a sensing element LG-Ni1000.

4.2.2 Error handling

A flow sensor with short-circuit or interruption always leads to an error message, irrespective of the type of plant. In that case, the heating circuit pump is activated and the mixing valve on the primary side is driven to the fully closed position when using a mixing circuit, the heating circuit pump is deactivated when using a pump circuit. In all cases, an error message is delivered. This means:

- The controller's LCD displays *Er*
- If there is a short-circuit or interruption and the flow temperature is queried, the display of the QAW70 room unit shows ---

4.3 Outside temperature (B9)

4.3.1 Types of sensors

The following types of sensors can be used:

- Outside sensor QAC22 (sensing element LG-Ni1000)
- Outside sensor QAC32 (sensing element NTC 575)

The controller identifies automatically the connected type of sensor. The measuring range is $-50 \dots 50$ °C.

The outside temperature can also be acquired via LPB (refer to chapter 20.2.4 "Outside temperature source").

4.3.2 Error handling

If there is a short-circuit or an interruption in the outside sensor's measuring circuit, the control system responds as follows:

- Plants with room sensor: The controller switches to room temperature control
- Plants without room sensor: The controller provides control based on an outside temperature of 0 °C

An error message is delivered only if the current room temperature is not available. This is the case if no room unit is connected or if the room temperature measuring circuit is faulty.

The error message means:

- The controller's LCD displays *Er*
- If there is a short-circuit or an interruption and the outside temperature is queried, the display of the QAW70 room unit shows ---

4.4 Room temperature (A6)

4.4.1 Types of sensors

The room temperature is acquired via a PPS (point-to-point interface). The device connected to the PPS must deliver a suitable output signal. The measuring range is 0...32 °C. Suitable types of devices are:

- Room unit QAW50...
- Room unit QAW70
- Room sensor QAA10

Note:

If a room unit or room sensor is used in both heating circuits, 1 of the 2 devices must be addressable. This means:

- The first room unit can be a QAA10, QAW50, QAW50.03 or QAW70
- The second room unit must be a QAW50.03 or QAW70 using address 2

4.4.2 Error handling

- A short-circuit in the measuring circuit leads to an error message
- An interruption in the measuring circuit does not lead to an error message since a room unit is not necessarily connected

4.4.3 Room model

The RVD260 provides a fixed room model for each heating circuit. It simulates the room temperature based on the progression of the outside temperature and the type of building construction, using a defined attenuation. In systems with no acquisition of the room temperature, the room model ensures optimum start control.

4.5 D.h.w. flow temperature (B3)

4.5.1 Acquisition of measured value

With all types of d.h.w. plants, the temperature of the d.h.w. flow is acquired via input B3.

4.5.2 Types of sensors

Suitable are all types of Siemens sensors using a sensing element LG-Ni1000.

4.5.3 Error handling

If there is a malfunction (short-circuit or interruption), an error message is delivered. In the event of error, the plant responds as follows, depending on the type of d.h.w. actuating device used:

- The d.h.w. intermediate circuit pump is deactivated
- The mixing valve is driven to the fully closed position
- If pump charging is active, it is aborted by deactivating the storage tank charging pump

If there is a short-circuit or an interruption and the d.h.w. temperature is queried, the display of the QAW70 room unit shows ---.

4.6 D.h.w. storage tank temperature (B31, B32)

4.6.1 Acquisition of measured value

The storage tank temperature is acquired via input B31. Depending on the type of plant, a second storage tank sensor is connected to input B32.

4.6.2 Type of sensor

1 or 2 sensors with LG-Ni1000 sensing element can be used.
Thermostats cannot be used.

4.6.3 Error handling

The controller's response to errors in the measuring circuits depends on the way the d.h.w. storage tank sensor is parameterized (setting on operating line 98).

Automatic selection of sensor (operating line 98 = 0)

If there is a fault (short-circuit or interruption) in only 1 measuring circuit, the controller continues to work with the other measuring circuit. An error message is not delivered. If both measuring circuits do not produce a valid measured value, an error message is delivered. The d.h.w. pump is deactivated.

1 sensor with solar d.h.w. heating (operating line 98 = 1)

If there is a fault (short-circuit or interruption) in only 1 measuring circuit, the controller continues to work with the other measuring circuit. An error message is not delivered. If both measuring circuits do not produce a valid measured value, an error message is delivered. The d.h.w. pump and the collector pump are deactivated.

2 sensors with solar d.h.w. heating (operating line 98 = 2)

If there is a fault (short-circuit or interruption) in 1 of the measuring circuit, the controller continues to work with the other measuring circuit. An error message is delivered. If both measuring circuits do not produce a valid measured value, 2 error messages are delivered. The d.h.w. pump and the collector pump are deactivated.

If a measured value of the d.h.w. temperature is not available and the temperature is queried, the QAW70 room unit displays ---.

4.7 D.h.w. return temperature (B32)

4.7.1 Acquisition of measured value

With plant types x-4, the return temperature in the d.h.w. circuit is acquired via input B32.

4.7.2 Type of sensor

Suitable are all types of Siemens sensors using a sensing element LG-Ni1000:

4.7.3 Error handling

A short-circuit in the measuring circuit leads to an error message.

4.8 Return temperature (B7, B71, B72)

4.8.1 Acquisition of measured value

Depending on the type of plant, the return temperature (primary and secondary) is acquired via inputs B7, B71 and B72.

With plant types 2-x and 3-x, the primary return temperature acquired by B7 is forwarded via LPB.

4.8.2 Type of sensor

Suitable are all types of Siemens sensors using a sensing element LG-Ni1000.

4.8.3 Error handling

Secondary return sensor

In the event of a faulty secondary return sensor (short-circuit or interruption), an error message is delivered when maximum limitation of the primary and secondary return temperature or the return temperature differential limit function has been activated. The controller's LCD shows *Er*.

Primary return sensor

In the event of a faulty primary return sensor (short-circuit or interruption), an error message is delivered when maximum limitation of the primary return temperature or the return temperature differential limit function has been activated. The controller's LCD shows *Er*.

If maximum limitation of the secondary return temperature is activated (by making an entry on operating line 232; difference to the primary limit value), an error message is deliberately not delivered.

4.9 Collector temperature (B72)

4.9.1 Type of sensor

The collector temperature is acquired by a Siemens sensor with sensing element LG-Ni1000 and an extended measuring range.

4.9.2 Error handling

In the event of an interruption of the measuring circuit, an error message is delivered with a delay of 12 hours and the collector pump is deactivated. This means that solar d.h.w. heating is no longer provided.

The controller's LCD shows *Er*.

4.10 Pressure sensors (U1, U2)

4.10.1 Acquisition of measured value

The primary and secondary plant pressure for the refill function can be acquired via inputs U1 and U2.

4.10.2 Type of sensor

Suitable are sensors delivering DC 0...10 V signals. The resulting pressure values for 0 V and 10 V can be set (refer to chapter 26.3.9 "Configuration of sensors").

4.10.3 Error handling

If the sensor acquires a pressure below 0.2 bar (short-circuit or interruption), an error message is delivered and the valve is fully closed.
The controller's LCD shows **Er**.

5 Function: Space heating

5.1 Operating lines

The "Space heating" function provides settings and displays for the end-user. The buttons for selecting the operating lines and for changing settings are described in chapter 31.1 "Operation".

Line	Function, parameter	Factory setting (range)	Unit
1	Current room temperature setpoint	Display function	°C
2	Reduced room temperature setpoint	14.0 (variable*)	°C
3	Setpoint for frost protection/holiday mode	8 (variable*)	°C
5	Heating curve slope	1.5 (0.25...4.0)	
6	Weekday for entering the heating program	Current weekday (1...7/1-7)	
7	Heating period 1 start	06:00 (--:--/00:00...24:00)	hh:mm
8	Heating period 1 end	22:00 (--:--/00:00...24:00)	hh:mm
9	Heating period 2 start	--:-- (--:--/00:00...24:00)	hh:mm
10	Heating period 2 end	--:-- (--:--/00:00...24:00)	hh:mm
11	Heating period 3 start	--:-- (--:--/00:00...24:00)	hh:mm
12	Heating period 3 end	--:-- (--:--/00:00...24:00)	hh:mm

5.2 Settings and displays

- The nominal room temperature setpoint is adjusted with the setting knob (scale in °C).
The room temperature is then maintained at this setpoint:
 - In automatic operation → during the heating periods
 - In continuous operation ⊗ → always
- Operating line 1 on the LCD shows the current room temperature setpoint for each heating circuit. Depending on operating mode and operating state, following applies:

Operating mode and operating state	Displayed setpoint
Heating to nominal setpoint	Adjustment made with the setting knob (incl. readjustment made on the room unit)
Heating to reduced setpoint	Reduced setpoint (setting operating line 2)
Continuous operation	Adjustment made with the setting knob
Quick setback	Reduced setpoint (setting operating line 2)
Frost protection mode	Setpoint for frost protection (setting operating line 3)
OFF via ECO	During heating periods: Adjustment made with the setting knob (incl. readjustment made on the room unit). Outside heating periods: Reduced setpoint

- The reduced room temperature setpoint is to be set on operating line 2, separately for each heating circuit. At the top, the setting range is limited by the nominal setpoint, at the bottom, by the setpoint for frost protection. This is the setpoint maintained outside the heating periods
- The setpoint for frost protection is to be set on operating line 3, separately for each heating circuit. The setting range is from 8 °C (fixed value) to the adjusted reduced setpoint. Hence, this frost protection acts as frost protection for the house or the building.
This setting is also the setpoint used for holiday mode. A holiday program can be entered on the controller or on the QAW70 room unit. For more detailed information, refer to chapter 9 "Function: Holiday settings" (operating lines 31...33) and chapter 30.3 "Combination with room unit QAW70"
- The heating curve slope is to be set on operating line 5, separately for each heating circuit. The setting range is from 0.25 to 4.0. For more detailed information, refer to chapter 12.3 "Heating curve"

The setpoints for the nominal temperature and the reduced temperature plus that for frost protection are to be entered directly in °C room temperature. They always apply, independent of whether or not the control uses a room sensor. Without room sensor, the heating curve or the room model is taken into consideration.

5.3 Heating program

The heating program of the RVD260 provides a maximum of 3 heating periods per day; also, every weekday can have different heating periods. Every heating period is defined by a start and an end.

Using "1-7" on operating line 6, it is possible to enter a heating program for each heating circuit that applies to all weekdays. This simplifies the settings: If the weekend times differ, first enter the times for the entire week, then change days 6 and 7 as required.

The settings are sorted and overlapping heating periods are combined.

When setting --:-- for the start or the end, the heating period is deactivated.

Using the QAW70 room unit, the heating program can be changed from a remote location.

6 Function: Setting the clock

6.1 Operating lines

Function "Setting the clock" function provides settings and displays for the end-user.

<i>Line</i>	<i>Function, parameter</i>	<i>Factory setting (range)</i>	<i>Unit</i>
13	Time of day	(00:00...23:59)	hh:min
14	Weekday	Display function	d
15	Date	(01.01...31.12)	dd.mm
16	Year	(2009...2099)	yyyy

6.2 Entries

The RVD260 has a yearly clock with the time of day, the weekday and the date. The weekday on operating line 14 is automatically determined based on the set date and cannot be changed.

The change from summer- to wintertime, and vice versa, takes place automatically. Should the respective regulations change, the changeover dates can be adjusted (refer to operating lines 144 and 145).

7 Function: D.h.w.

7.1 Operating lines

The "D.h.w." function provides settings and displays for the end-user.

Line	Function, parameter	Factory setting (range)	Unit
17	Weekday for entering the d.h.w. program	Current weekday (1...7/1-7)	
18	Release period 1 start	06:00 (--:--/00:00...24:00)	hh:min
19	Release period 1 end	22:00 (--:--/00:00...24:00)	hh:min
20	Release period 2 start	--:-- (--:--/00:00...24:00)	hh:min
21	Release period 2 end	--:-- (--:--/00:00...24:00)	hh:min
22	Release period 3 start	--:-- (--:--/00:00...24:00)	hh:min
23	Release period 3 end	--:-- (--:--/00:00...24:00)	hh:min
41	Nominal d.h.w. setpoint	55 (variable)	°C
42	Reduced d.h.w. setpoint	40 (variable)	°C

7.2 D.h.w. program

The d.h.w. program of the RVD260 offers 3 release phases per day. In addition, every weekday can have different release phases. Every release phase is defined by a start and an end.

Using "1-7" on operating line 17, it is possible to enter a d.h.w. program that applies to all weekdays. Entry is thus simplified. If the weekend times differ, first enter the times for the entire week, then change days 6 and 7 as required.

The settings are sorted and overlapping release phases are combined.

When setting --:-- for the start or the end, the release phase is deactivated.

D.h.w. charging can also be released according to other programs. The selection is made on operating line 101.

7.3 Adjustment of setpoints

- The nominal d.h.w. setpoint is to be set on operating line 41. Its setting range depends on the type of plant (for detailed information, refer to chapter 16.5 "Maximum setpoint for d.h.w. temperature")
- The reduced d.h.w. setpoint is to be set on operating line 42, between 8 °C and the nominal setpoint. When used with the d.h.w. program, it applies to the periods of time between the release phases (refer to chapter 7.2)

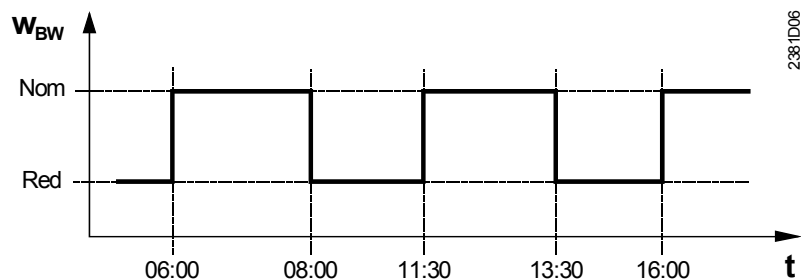

Nom Nominal setpoint
Red Reduced setpoint
t Time
 w_{BW} D.h.w. temperature setpoint

8 Function: Display of sensor values

8.1 Operating lines

Function "Display of sensor values" provides displays for the end-user.

<i>Line</i>	<i>Function, parameter</i>	<i>Factory setting (range)</i>	<i>Unit</i>
24	Room temperature	Display function	°C
25	Outside temperature	Display function	°C
26	D.h.w. temperature	Display function	°C
27	Flow temp. heating circuit	Display function	°C

8.2 Displays

- Room temperature:
If a room sensor/room unit (A6) is connected to the PPS interface, the acquired temperature is displayed
- Outside temperature:
The outside temperature displayed is the temperature acquired by the outside sensor (B9) or that supplied via the data bus (refer to chapter 20.2.4 "Outside temperature source")
When buttons $\bar{\square}$ and $\bar{\square}^+$ are pressed for 3 seconds, the displayed outside temperature is adopted as the composite and the attenuated outside temperature (outside temperature reset)
- D.h.w. temperature:
The temperature displayed is the temperature acquired by the d.h.w. sensor. Depending on the plant configuration, this can be d.h.w. flow sensor B3 (plant types x-4) or storage tank sensor B31 (other plant types with the exception of x-0).
If button $\bar{\square}$ or $\bar{\square}^+$ is pressed, the controller displays the current setpoint
- Flow temperature heating circuit:
The temperature displayed separately for each heating circuit is the temperature acquired by the relevant sensor.
If button $\bar{\square}$ or $\bar{\square}^+$ is pressed, the controller displays the current setpoint

9 Function: Holiday settings

9.1 Operating lines

Function "Holiday settings" provides settings for the end-user.

<i>Line</i>	<i>Function, parameter</i>	<i>Factory setting (range)</i>	<i>Unit</i>
31	Holiday period	1 (1...8)	
32	Date of first day of holiday period	--.-- (--.--/01.01...31.12)	dd.mm
33	Date of last day of holiday period	--.-- (--.--/01.01...31.12)	dd.mm

9.2 Holiday program

A maximum of 8 holiday periods per year can be programmed. At 00:00 of the first day of the holiday period, changeover to the setpoint for frost protection/holiday mode takes place. At 24:00 of the last day of the holiday period, the controller switches to NORMAL or REDUCED heating in accordance with the time switch settings.

The settings for a holiday period are deleted when the respective period has elapsed.

Holiday periods may overlap. It is not necessary to observe a certain order. Depending on the setting made on operating line 125 (assignment d.h.w. charging), the holiday function deactivates d.h.w. heating and the circulating pump.

The holiday program is only active in automatic operation and applies to both heating circuits.

10 Function: Display of faults

10.1 Operating line

Function "Display of faults" provides displays for the end-user.

Line	Function, parameter	Factory setting (range)	Unit
50	Faults	Display function	

10.2 Display of faults

Faults detected by the controller are shown on the display as **Er** (error) and appear on operating line 50 in the form of an error code:

Error code	Cause of fault
10	Fault outside sensor B9
30	Fault flow sensor B1
32	Fault flow sensor B12
40	Fault primary return sensor B7*
42	Fault return sensor B71
43	Fault return sensor B72
50	Fault storage tank sensor B31
52	Fault storage tank sensor B32
54	Fault flow sensor B3
61	Fault room unit A6, heating circuit 1
62	Unit with wrong PPS identification connected, heating circuit 1
66	Fault room unit A6, heating circuit 2
67	Unit with wrong PPS identification connected, heating circuit 2
73	Fault collector sensor B72
78	Fault secondary pressure sensor U1
81	Short-circuit on data bus (LPB)
82	2 devices with the same bus address (LPB)
86	Short-circuit PPS
100	2 clock time masters
120	Flow alarm common flow
121	Flow alarm heating circuit 1
122	Flow alarm heating circuit 2
123	Flow alarm d.h.w. flow
140	Inadmissible bus address (LPB)
170	Fault primary pressure sensor U2
171	Alarm from input H5
180	Connection to heat meter at input H5 interrupted
181	Configuration error PWM pump (operating lines 52, 54, 58, 231, 232, 235)
182	Configuration error return temperature differential (operating lines 52, 53, 234)
183	Configuration error maximum limitation of secondary return temperature (operating lines 52, 54, 58, 226, 231, 232, 235)
184	Configuration error refill function (operating lines 52, 129, 130, 211)
185	Configuration error solar function (operating lines 54, 98, 129, 130)
195	Maximum refill period per charging cycle reached
196	Maximum refill period per week reached

* If maximum limitation of the secondary return temperature is activated (by making an entry on operating line 232; lowering against the primary limit value), no error message is delivered

11 Function block: Plant configuration

11.1 Operating lines

Function block "Plant configuration" provides settings for the heating engineer.

<i>Line</i>	<i>Function, parameter</i>	<i>Factory setting (range)</i>	<i>Unit</i>
51	Plant type	1-0 (1-0...4-9)	
52	Function of input at terminals B71/U1	1 (0...4)	
53	Function of input at terminals B7/U2	0 (0...2)	
54	Function of input at terminal B72	0 (0...1)	
55	Function of circulating pump	0 (0...3)	
56	Function of contact connected to terminal H5	0 (0...4)	
57	Impulse of pulse input on the heating circuits	1 (1...3)	
58	Assignment of speed-controlled pump	0 (0...4)	
147	Minimum speed of speed-controlled pump	50 (0...variable)	%
148	Maximum speed of speed-controlled pump	100 (variable...100)	%
149	Power factor at reduced pump speed	85 (0...100)	%

11.2 Parameter settings

The required functions and settings or the assigned operating lines are activated by selecting the required type of plant. All other operating lines are deactivated and hidden.

11.2.1 Plant type

The type of plant is to be entered on operating line 51. Features are the following: The RVD260 offers a total of 14 plant types. The individual plant types are presented in chapter 3.2 "Plant types"

- Plant types x-0 only provide flow temperature control of the heating circuits (no d.h.w. heating)
- In terms of space heating, it is possible to have mixing or pump heating circuits
- D.h.w. can be supplied via...
 - coil type storage tank,
 - heat exchanger,
 - stratification storage tank.
- Actuating device can be an intermediate circuit pump, charging pump, circulating pump or mixing valve

11.2.2 Input B71/U1

The function of input (terminal) B71/U1 is to be selected on operating line 52.

Setting choices:

- Setting 0:
The RVD260 identifies the connected sensor as a return temperature differential sensor
- Setting 1:
The connected sensor is used as a return sensor in a heating or d.h.w. circuit. It is to be noted that when using a speed-controlled pump, sensor B71 must always be present in the return of the respective control loop
- Setting 2:
The RVD260 can receive DC 0...10 V signals from plant elements and then pass them on via M-bus. Plant element can be a differential pressure sensor, for instance. The signals have no impact on the control functions of the RVD260

- Setting 3:
B71/U1 acts as a scalable DC 0...10 V input to receive the heat demand from other devices
- Setting 4:
The connected sensor is used as a secondary pressure sensor for the refill function.
For details of the refill function, refer to chapter 26 "Function block: Refill functions"

11.2.3 Input B7/U2

The function of input (terminal) B7/U2 is to be selected on operating line 53.

Setting choices:

- Setting 0:
The RVD260 uses the connected sensor as a primary return sensor
- Setting 1:
The connected sensor is used as a primary pressure sensor for display in connection with the refill function
- Setting 2:
The connected sensor is used as a primary pressure sensor for monitoring in connection with the refill function

11.2.4 Input B72

The function of input (terminal) B72 is to be selected on operating line 54.

Setting choices:

- Setting 0:
The RVD260 uses the connected sensor as a return sensor
- Setting 1:
The connected sensor is used as a collector sensor in connection with solar d.h.w. heating.
For details of the solar function, refer to chapter 25 "Function block: Solar d.h.w."

11.2.5 Circulating pump

The circulating pump is to be configured on operating line 55.

0 = no circulating pump present

1 = water is fed into the storage tank; only when d.h.w. heating is activated

2 = water is fed into the heat exchanger's secondary return, whereby 80% of the heat losses are compensated for

3 = water is fed into the heat exchanger's secondary return, whereby 100% of the heat losses are compensated for

When using setting 2 or 3, the circulating pump runs continuously during the whole period of time d.h.w. heating is released. Refer to chapter 15.12.6 "Compensation of heat losses".

11.2.6 Input H5

The setting choices for input (terminal) H5 on operating line 56 are the following:

0 = no function

1 = reception of pulses:

with plant type 1-x, the mode of operation of the pulse input is to be selected on operating line 57:

1 = only acting on heating circuit 1

2 = only acting on heating circuit 2

3 = acting on both heating circuits

With the other plant types, the function always acts on 2-port valve Y1 in the primary return.

For more detailed information, refer to chapter 28 "Function block: Miscellaneous", operating lines 236 through 238

2 = reception of heat demand signals:

For more information, refer to chapter 13 "Function block: Valve actuator heat exchanger", operating lines 87 and 88

3 = input for alarm signals:

It is possible to receive error messages. They are displayed with error code 171 on operating line 50 and can be forwarded via LPB or M-bus

4 = input for flow switch:

To improve the control performance, an optional flow switch can be fitted in the d.h.w. circuit of several types of plant

Input H5 requires a gold-plated switching contact. This contact is not allowed to switch mains voltage and must never have been used with mains voltage before.

11.2.7 Speed-controlled pump

Use

The RVD260 features a pulse-width-modulated output for a speed-controlled pump. The controller calculates the ideal speed for the pump, based on temperature conditions. The speed-controlled pump is to be selected on operating line 58.

Setting	Terminal	Used as
0	–	No speed-controlled pump
1	Q1	Heating circuit pump M1 in heating circuit 1
2	Q2	Heating circuit pump M2 in heating circuit 2
3	Q3	Intermediate circuit pump M3 in connection with coil type storage tanks
4	Q4	Storage tank charging pump M4 in connection with stratification storage tanks

In the case of manual control, the speed-controlled pump operates at the nominal speed.

The intermediate circuit pump used in connection with stratification storage tanks and the circulating pump are not speed-controlled.

If the pulse-width-modulated output is assigned to a pump that is not available with the respective plant type, it stays at 0%.

Minimum and maximum speed

- Operating line 147 is used to set the minimum speed as a percentage of the nominal speed. It should be selected as low as possible, but must be high enough to ensure that all consumers receive sufficient amounts of heat. The relay assigned to the pump is still connected in parallel and can be used to fully deactivate the pump when not in use. The setting range reaches from 0% to the value set on operating line 148
- Operating line 148 is used to set the maximum speed as a percentage of the nominal speed. If, due to the hydraulic layout, the maximum pump head must be reduced, this

should be done by reducing the maximum pump speed since this saves pumping power. If the pump is allowed to operate at its rated capacity, the maximum speed is maintained at 100%.

The setting range reaches from the value set on operating line 147 to 100%

Control of heating circuit pump

The following graph shows the control of the heating circuit pump. It shows the pump speed and the flow and return temperatures as a function of the outside temperature. In the upper outside temperature range (range 1; in the example $T_A = 20 \dots -5 \text{ °C}$), the pump speed is maintained at its minimum until the flow temperature – according to the heating curve – would exceed the flow temperature setpoint T_{Vmax} (operating point C). In the lower outside temperature range (range 2; in the example $T_A = -5 \dots -10 \text{ °C}$), the flow temperature is then maintained at a constant level of T_{Vmax} . But the pump speed is continuously increased until the selected maximum speed is reached (operating point A; $T_A = -10 \text{ °C}$).

The heat output at operating point A is the same as the heat output that would result at operating point B (flow temperature according to the heating curve, minimum pump speed).

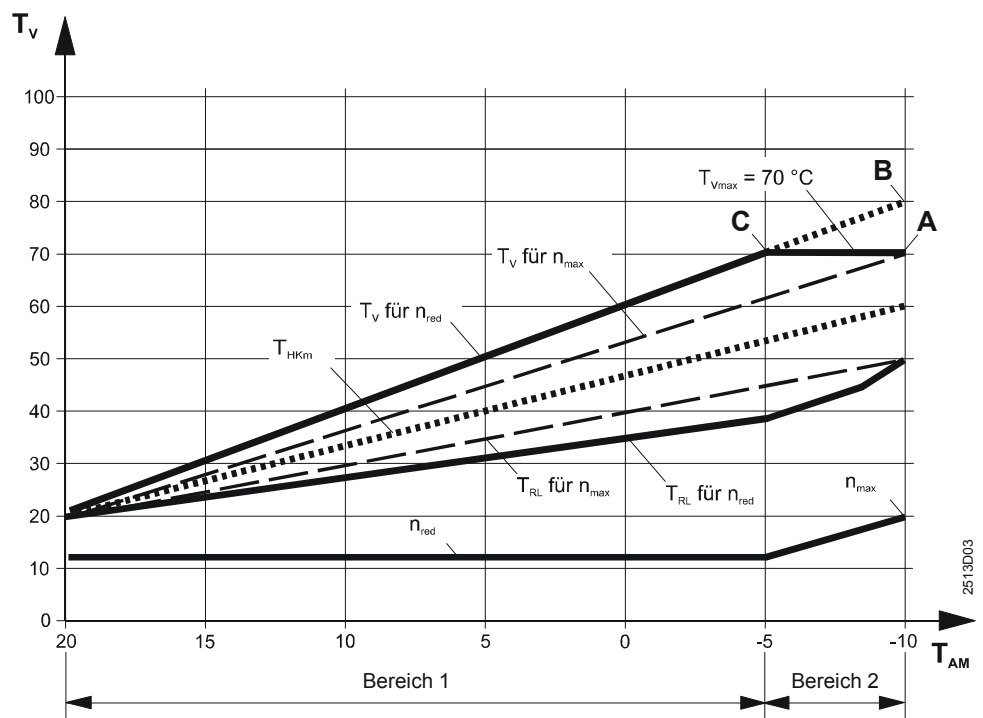

A	Operating point A (maximum speed reached)	T_{HKm}	Mean radiator temperature
B	Operating point B (theoretical heat output)	T_{RL}	Return temperature
C	Operating point C (effective heat output)	T_V	Flow temperature
n_{max}	Maximum speed	T_{Vmax}	Maximum limit of flow temperature
n_{red}	Reduced speed		

Notes on the example shown above:

- The heating system is designed such that it reaches its maximum capacity at an outside temperature of -10 °C (no spare capacity for heating up processes). At this outside temperature, both pump speed and flow temperature are at their maximum

- With this kind of plant design, it is assumed that the outside temperature hardly ever drops below -5 °C. But during heating up processes, the pump speed is also increased above the minimum speed whenever the outside temperature lies above -5 °C

Lower pump speeds mean:

- Energy savings due to reduced pumping power
- Greater differential of heating flow and return temperature
- Lower return temperatures

The heating circuit is controlled based on the signal received from the heating circuit's flow sensor.

Maximum flow temperature

By setting the maximum flow temperature (operating line 95) the maximum flow temperature setpoint is defined on the one hand. On the other hand, the same setting defines the range from what flow temperature the pump speed shall be increased. The maximum flow temperature should always be selected as high as permitted by the heating system. The higher the flow temperature setting, the longer the pump operates at minimum speed. Also, the heating circuit's maximum output will not be restricted unnecessarily.

Power factor

The graph shows that at outside temperatures below operating point C, the pump speed is increased from minimum to maximum. To define the rate at which the pump speed shall be increased, the radiators' power factor is to be set. The power factor is the ratio of radiator output at minimum pump speed and that at maximum pump speed:

$$\text{Power factor} = \frac{\text{Radiator output at minimum speed}}{\text{Radiator output at maximum speed}}$$

The factory setting is 85%. If the plant is correctly sized, this setting ensures satisfactory performance and, for this reason, necessitates readjustments in exceptional cases only. Incorrect settings only have an impact at extremely low outside temperatures, but the impact is small.

The power factor of the speed-controlled pump at minimum speed is to be set on operating line 149.

If, with plant types 2-x, 3-x and 4-x, the common flow temperature is not reached, the speed of the heating circuit pump does not change because speed control only acts on the heating circuit pump.

Control of intermediate circuit pump

The intermediate circuit pump operates at maximum speed until the limit of maximum return temperature limitation is exceeded. Then, the speed is continuously reduced, giving the heating water more time to transfer heat to the storage tank.

The intermediate circuit pump is controlled according to the temperature acquired by the closest return sensor. For that, the following setpoints and actual values are used:

<i>Plant type</i>	<i>Actual value (sensor)</i>	<i>Setpoint</i>
2-1, 3-1, 2-2	B71	[Maximum setpoint of the return temperature during d.h.w. charging*] minus [differential to the primary limit value with maximum limitation of the secondary return temperature **]
1-3, 1-9	B71	Maximum setpoint of return temperature during d.h.w. charging
4-9	B72	

* Setting value operating line 231

** Setting value operating line 232

Control of storage tank charging pump

The d.h.w. flow temperature setpoint should be maintained as accurately as possible, allowing the storage tank to be fully charged in one go. At the beginning of d.h.w. heating, the storage tank charging pump starts at minimum speed until the d.h.w. flow temperature setpoint is reached. Then, the speed is continuously increased. During charging, the storage tank charging pump reduces its speed only if sufficient heat is not available.

The storage tank charging pump is controlled according to the d.h.w. flow temperature acquired by sensor B3; setpoint is the current d.h.w. temperature setpoint.

12 Function block: Space heating

12.1 Operating lines

Function block "Space heating" provides settings for the heating engineer.

Line	Function, parameter	Factory setting (range)	Unit
61	Heating limit (ECO)	-3 (---/-10...10)	K
62	Type of building construction	20 (0...50)	h
64	Date of first day of heating period	01.01 (01.01...31.12)	dd.mm
65	Date of last day of heating period	01.01 (01.01...31.12)	dd.mm
70	Influence of room temperature (gain factor)	10 (0...20)	
71	Parallel displacement of heating curve	0.0 (-15.0...+15.0)	K
72	Overrun time heating circuit pump	4 (0...40)	min
73	Maximum limitation of room temperature	--- (---/0.5...4)	K
74	Optimization with/without room sensor	0 (0/1)	
75	Maximum heating up period	0:00 (0:00...42:00)	h
76	Maximum early shutdown	0:00 (0:00...6:00)	h
77	Maximum rate of flow temperature increase	--- (---/1...600)	K/h
78	Quick setback	1 (0/1)	

12.2 Compensating variables

12.2.1 Outside temperature

The RVD260 makes use of 3 types of outside temperatures:

- The current outside temperature (T_A)
- The composite outside temperature (T_{AM}): It is generated by filtering the current outside temperature by the set building time constant. The proportion of the composite outside temperature is 50%.

The composite outside temperature prevents unnecessary responses by the control system if the outside temperature varies for short periods of time.



In the case of the weather-compensated control (without or with room influence), the RVD260 operates with the composite outside temperature.

The building time constant is a measure of the type of building construction and indicates how quickly the room temperature would change if the outside temperature changed suddenly. The building time constant is adjustable and applies to both heating circuits:

Type of building construction	Recommended building time constant
Light	10 h
Medium	20 h
Heavy	50 h

- The attenuated outside temperature (T_{AD}): It is generated by filtering twice the current outside temperature by the building time constant. This means that, compared with the current outside temperature, the attenuated outside temperature is considerably dampened. This ensures that no heating is provided in the summer when, in normal circumstances, the heating would be switched on because the outside temperature drops for a few days

Note:

If operating line 25 is selected (display of current outside temperature) and the 2 buttons  and  are pressed simultaneously for about 3 seconds, the attenuated and the composite outside temperature adopt the current measured value. The generation of the 2 variables is started again (outside temperature reset).

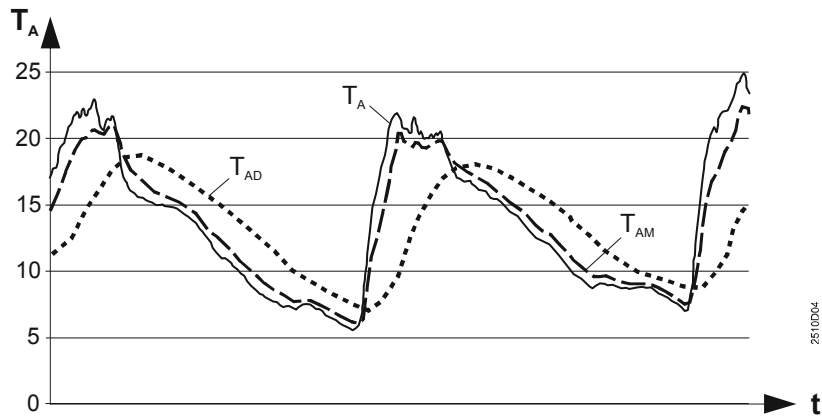

Progression of current, composite and attenuated outside temperature

T_A Current outside temperature
 T_{AD} Attenuated outside temperature
 T_{AM} Composite outside temperature
 t Zeit

12.2.2 Room temperature

The room temperature is included in the control process in the following way:

- With room temperature-compensated flow temperature control, the deviation of the current room temperature from the room temperature setpoint is the only compensating variable
- In the case of weather-compensated flow temperature control with room influence, it is an additional compensating variable

The gain factor for influence of the room temperature can be adjusted (operating line 70). This factor indicates to what extent a deviation in the room changes the room temperature setpoint, thus having an indirect impact (via the slope) on flow temperature control:

0 = room temperature deviation has no impact on the generation of setpoint

20 = room temperature deviation has a maximum impact on the generation of setpoint

Use of a room sensor (room unit) is mandatory.

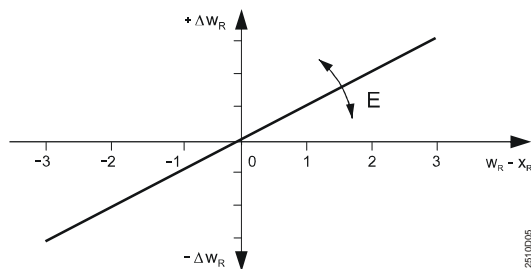

Gain factor of room temperature deviation

$-\Delta W_R$ Decrease of room temperature setpoint

$+\Delta W_R$ Increase of room temperature setpoint

E Influence

$W_R - X_R$ Setpoint minus actual value (room temperature)

The setpoint change Δw_R is calculated when in the static state according to the following formula:

$$\Delta W_R = \frac{\text{Factor of room influence } E}{2} \times (W_R - X_R)$$

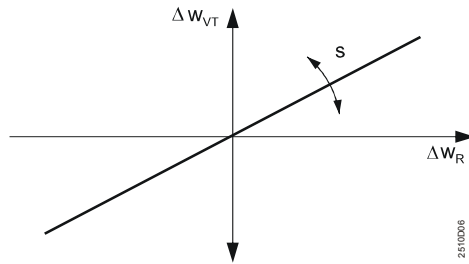

Impact of room temperature setpoint change on the flow temperature setpoint

- Δw_R Change of room temperature setpoint
- s Heating curve slope
- Δw_{VT} Change of flow temperature setpoint

The flow temperature setpoint change Δw_{VT} is calculated according to the following formula:

$$\Delta w_{VT} = \Delta w_R \times (s + 1)$$

12.3 Heating curve

With both types of weather-compensated flow temperature control (with/without room influence), the heating curve ensures assignment of the flow temperature setpoint to the outside temperature. The slope for each heating circuit is to be set separately on operating line 5.

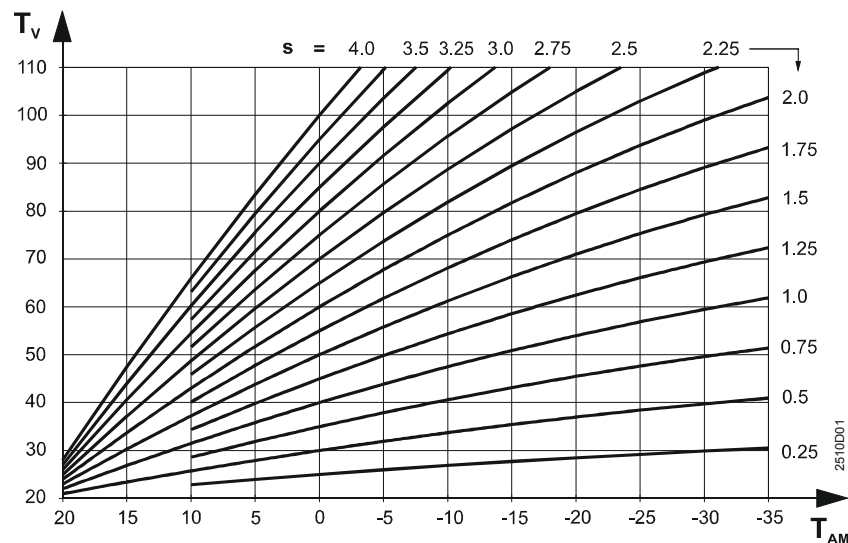

Heating curve

- s Slope
- T_{AM} Composite outside temperature
- T_V Flow temperature

The heating curve has a fixed pivotal point at an outside temperature of 22 °C and a flow temperature of 20 °C. It can be set about this pivotal point in the range from 0.25 to 4.0 in steps of 0.05.

Each heating curve has a substitute line which intersects the pivotal point and "its" heating curve at an outside temperature of 0 °C. Its slope is set on the controller and is calculated as follows:

$$s = \frac{\Delta T_V}{\Delta T_{AM}}$$

The use of a substitute line is required because the heating curve is slightly deflected. This is necessary to compensate for the nonlinear radiation characteristics of the different types of radiators.

Basic setting of heating curve

The basic setting of the heating curve applies to a room temperature setpoint of 20 °C and is to be made as per engineering documentation or according to local practices. If the basic setting does not ensure satisfactory operation, it is possible to manually enter a permanent parallel displacement of the heating curve on operating line 71.

12.4 Generation of setpoint

The setpoint is generated based on the heat demand from the heating circuits and the d.h.w. circuit.

The heat demand from the heating circuits is determined either by weather compensation, weather compensation with room influence, or room temperature compensation.

12.4.1 Display of setpoint

The effective setpoint generated by the controller, based on the different influencing factors, can be queried on operating line 27 by keeping button \leftarrow or \rightarrow depressed.

12.4.2 Setpoint for weather-compensated control

The setpoint is generated via the heating curve as a function of the outside temperature. The temperature used is the **composite** outside temperature.

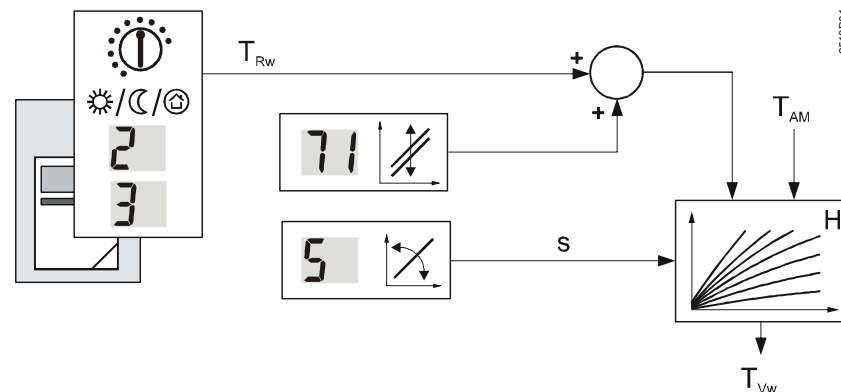

Generation of setpoint for weather-compensated control without room unit

- H Heating curve
- s Heating curve slope
- T_{AM} Composite outside temperature
- T_{Rw} Room temperature setpoint
- T_{Vw} Flow temperature setpoint
- 2 Operating line 2: Adjustment of reduced room temperature setpoint
- 3 Operating line 3: Adjustment of setpoint for frost protection
- 5 Operating line 5: Adjustment of heating curve slope
- 71 Operating line 71: Adjustment of heating curve's parallel displacement

12.4.3 Setpoint for room temperature-compensated control

The setpoint is generated based on the deviation of the current room temperature from the setpoint. In addition, the heating curve at a fixed outside temperature of 0 °C is taken into consideration.

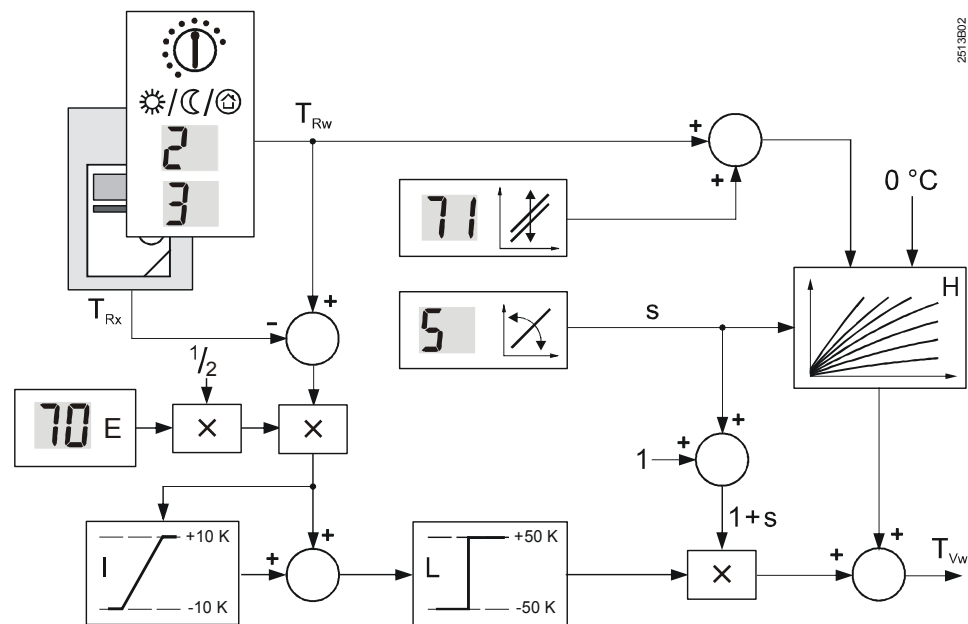

Generation of setpoint for room temperature-compensated control

- x Multiplier
- E Gain factor for room influence
- H Heating curve
- I Integrator with limitation
- L Limiter
- s Heating curve slope
- T_{Rw} Room temperature setpoint
- T_{Rx} Actual value of room temperature
- T_{Vw} Flow temperature setpoint
- 2 Operating line 2: Adjustment of reduced room temperature setpoint
- 3 Operating line 3: Adjustment of setpoint for frost protection
- 5 Operating line 5: Adjustment of heating curve slope
- 70 Operating line 70: Adjustment of gain factor for room influence
- 71 Operating line 71: Adjustment of heating curve's parallel displacement

12.4.4 Setpoint for weather-compensated control with room influence

Here, heating curve and room influence act on the flow temperature setpoint – in addition to the outside temperature and the room temperature setpoint.

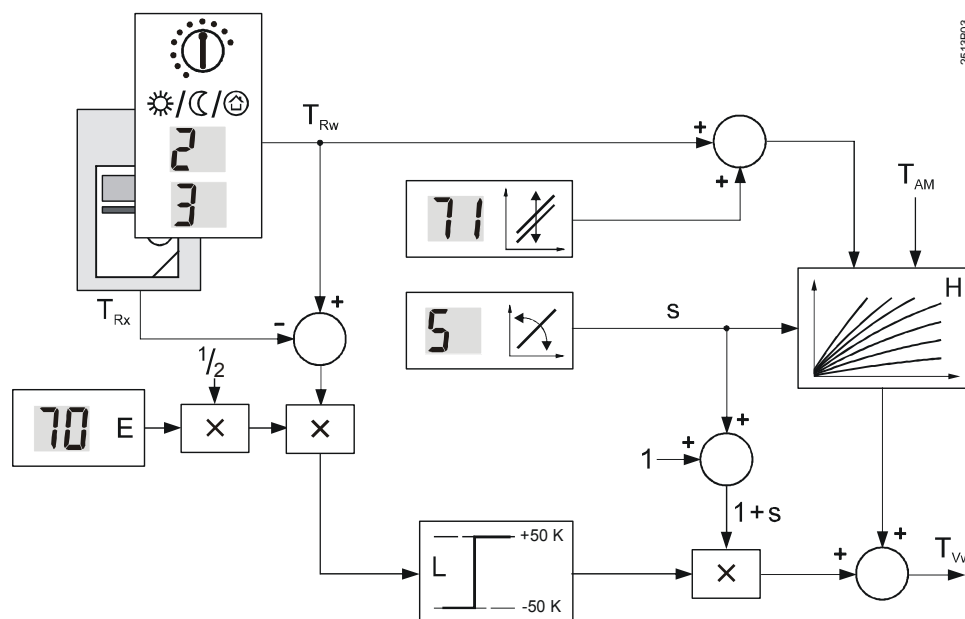

Generation of setpoint for weather-compensated control with room influence

- × Multiplier
- E Gain factor for room influence
- H Heating curve
- L Limiter
- s Heating curve slope
- T_{AM} Composite outside temperature
- T_{Rw} Room temperature setpoint
- T_{Rx} Actual value of room temperature
- T_{vw} Flow temperature setpoint
- 2 Operating line 2: Adjustment of reduced room temperature setpoint
- 3 Operating line 3: Adjustment of setpoint for frost protection
- 5 Operating line 5: Adjustment of heating curve slope
- 70 Operating line 70: Adjustment of gain factor for room influence
- 71 Operating line 71: Adjustment of heating curve's parallel displacement

12.5 Heating period

On operating lines 64 and 65, the first day (start) and the last day (end) of a heating period are to be entered. Outside the parameterized heating period, the heating circuit is switched off and the display shows ECO. Switching off takes place in addition to the automatic ECO function and summer-/wintertime changeover.

Frost protection for the building and the plant remain ensured. The function has no impact on d.h.w. heating.

If the dates of the first day and last day coincide, the function is deactivated.

12.6 Heating circuit control

The 2 heating circuits are controlled separately.

12.6.1 Weather-compensated control

Prerequisites for this type of control:

- Outside sensor connected
- No room unit connected or, if connected, room influence set to 0 (minimum)

The compensating variable for weather-compensated control is the composite outside temperature. Assignment of the flow temperature setpoint to the compensating variable is made via the adjusted heating curve. The room temperature is not taken into consideration.

Main application of this type of control are plants or buildings in which...

- several rooms are used at the same time,
- none of the rooms is suited as a reference room for the room temperature.

12.6.2 Room temperature-compensated control

Prerequisites for this type of control:

- Room unit connected
- No outside sensor connected

If no room unit is connected, the setting on operating line 70 (room influence) has no impact.

The compensating variable for room temperature-compensated control is the deviation of the actual room temperature from the setpoint; it is used to generate the room influence. In addition, an assumed outside temperature of 0 °C is included in the generation of the setpoint.

- When there is no room temperature deviation, the controller maintains the flow temperature setpoint generated by the heating curve slope at an outside temperature of 0 °C
- Any room temperature deviation produces an immediate parallel displacement of the adjusted heating curve. The correlation between the deviation and the extent of the displacement is defined by the room influence. It is dependent on the...
 - deviation of the current room temperature from the setpoint,
 - adjusted heating curve slope,
 - adjusted factor for the room influence.

The purpose of room influence is to exactly reach the required setpoint during the control process and to maintain it.

This type of control provides PI control mode. During the control process, the I-part ensures that any deviations from the room temperature setpoint are corrected without proportional offset.

Main application of this type of control are plants or buildings where one of the rooms is suited as a reference room for the room temperature.

12.6.3 Weather-compensated control with room influence

Prerequisites for this type of control:

- Outside sensor connected
- Room unit connected
- Room influence set in the range 1...20

Compensating variables for weather-compensated control with room influence:

- The composite outside temperature
- The deviation of the current room temperature from the setpoint

The flow temperature setpoint is continuously shifted via the heating curve by the composite outside temperature. In addition, any deviation of the current room temperature from the setpoint leads to an immediate parallel displacement of the heating curve. The correlation between the deviation and the extent of the displacement is defined by the room influence. It is dependent on the...

- adjusted factor for the room influence,
- deviation of the current room temperature from the setpoint,
- adjusted heating curve slope.

These 3 factors are used to generate the correcting variable for the flow temperature setpoint.

Main application of this type of control are well insulated buildings or buildings with considerable heat gains where...

- several rooms are used at the same time,
- one of the rooms is suited as a reference room for the room temperature.

12.7 Automatic ECO function

12.7.1 Basics

The automatic ECO function is active with all types of plant and acts separately on both heating circuits. It controls the heating system depending on demand. This function gives consideration to the progression of the room temperature depending on the type of building construction and depending on outside temperature variations. If the amount of heat stored in the building is sufficient to maintain the current room temperature setpoint, ...

- the heating circuit pump is deactivated (pump can only be switched on again by frost protection for the plant),
- the heating circuit mixing valve or heating circuit valve is fully closed.

In the individual operating modes, the automatic ECO function behaves as follows:

<i>Operating mode</i>	<i>Automatic ECO function is...</i>
Automatic operation	active
Continuous operation	inactive
Protection mode (standby)	active
Manual control	inactive

With the RVD260, the automatic ECO function is subdivided into 2 part functions. For more information, refer to the following chapters. The automatic ECO function can be deactivated.

12.7.2 Compensating and auxiliary variables

Note:

Also refer to chapter 12.7.2 "Compensating and auxiliary variables".

The automatic ECO function requires an outside sensor. As a compensating and auxiliary variable, the automatic ECO function takes into account the progression of the outside temperature. The following variables are taken into consideration:

- The current outside temperature (T_A)
- The attenuated outside temperature (T_{AD}): Compared to the current outside temperature, the attenuated outside temperature is considerably damped. This ensures that no heating is provided in the summer when, in normal circumstances, the heating would be switched on because the outside temperature drops for a few days
- The composite outside temperature (T_{AM}): Since – compared to the current outside temperature – the composite outside temperature is attenuated, it represents the impact of short-time outside temperature variations on the room temperature as they often occur during intermediate seasons (spring time and autumn)

The thermal inertia of the house or building in the case of outside temperature variations is taken into account by including the composite outside temperature in the automatic ECO function.

12.7.3 Heating limit

The automatic ECO function necessitates a heating limit. An ECO temperature in the range $-10...10$ K can be set separately for each heating circuit (operating line 61). This setting value and the room temperature setpoint are used to calculate the heating limit. The switching differential of 1 K for switching on/off is entered as a fixed value.

12.7.4 Mode of operation of ECO function 1

ECO function 1 operates as an automatic summer/winter function. The heating is switched off (heating circuit pump off, valve fully closed) when the attenuated outside temperature exceeds the heating limit.

The heating is switched on again when all 3 outside temperatures have dropped by the switching differential below the heating limit. The heating limit is determined as follows:

Heating limit = $T_{RWN} + T_{ECO}$ (nominal room temperature setpoint plus ECO temperature)

Example:

A nominal room temperature setpoint w_N of $+20$ °C and an ECO temperature T_{ECO} of -5 K result in a heating limit of $+15$ °C.

12.7.5 Mode of operation of ECO function 2

ECO function 2 operates as an automatic 24-hour heating limit. The heating is switched off (heating circuit pump off, valve fully closed) when the actual **or** the composite outside temperature exceeds the heating limit.

The heating is switched on again when all 3 outside temperatures have dropped by the switching differential below the heating limit. The heating limit is determined as follows:

Heating limit = $T_{Rw\text{ akt}} + T_{ECO}$ (current room temperature setpoint plus ECO temperature)

In contrast to ECO function 1, ECO function 2 also gives consideration to reduced heating.

Example:

A current room temperature setpoint $T_{Rw\text{ akt}}$ of $+18$ °C and an ECO temperature of T_{ECO} of -5 K result in a heating limit of $+13$ °C.

The heating limit has a minimum limitation; it cannot drop below 2 °C.

12.8 Pump overrun

Pump overrun for the heating circuit pump can be set in the range $0...40$ minutes (operating line 72). Setting 0 deactivates pump overrun.

12.9 Maximum limitation of room temperature

For each heating circuit, the room temperature can be separately limited to a maximum. Required is a room sensor (sensor or room unit).

The limit value is generated from the nominal room temperature setpoint plus the value entered on operating line 73.

When the limit value is reached, the heating circuit pump is deactivated until the room temperature has again dropped below the setpoint.

Maximum limitation of the room temperature is independent of the setting used for the room influence.

12.10 Optimization

12.10.1 Definition and purpose

Operation of the heating system is optimized. EN 12 098 defines optimization as the "automatic shifting of the switch-on and switch-off points aimed at saving energy".

This means that...

- switching on and heating up as well as switching off are controlled such that during building occupancy times the required room temperature level is always ensured,
- the smallest possible amounts of energy are used to achieve this objective.

Optimization acts separately on each heating circuit; all settings are made separately per heating circuit.

12.10.2 Basics

Settings

- Operating line 74, type of optimization: 0 = according to room model without room sensor
1 = with room sensor or room unit

- Operating line 75: Maximum limit value for the heating up time
- Operating line 76: Maximum limit value for early shutdown
- Operating line 78: With or without quick setback

To perform optimization, the controller gives consideration to the current room temperature – acquired by a room sensor or room unit – or the room model. An outside sensor is always required.

With room sensor

When using a room sensor or room unit, it is possible to have optimum start **and** optimum stop control.

To be able to optimally determine the switch-on and switch-off points, optimization needs to "know" the building's heating up and cooling down characteristics, always as a function of the prevailing outside temperature.

For this purpose, optimization continually acquires the room temperature and the respective outside temperature. It captures these variables via the room sensor and the outside sensor and continually adjusts the forward shift of the switching points. This way, optimization can also detect changes made to the house or building and to take them into consideration.

The learning process always concentrates on the first heating period per day.

Without room sensor

Without room sensor, the following functions can be provided:

- Optimum start control: Operation with fixed values (no learning process), based on the set maximum heating up time and the room model
- Quick setback: Operation with fixed values (no learning process), based on the building time constant and the room model

12.10.3 Process

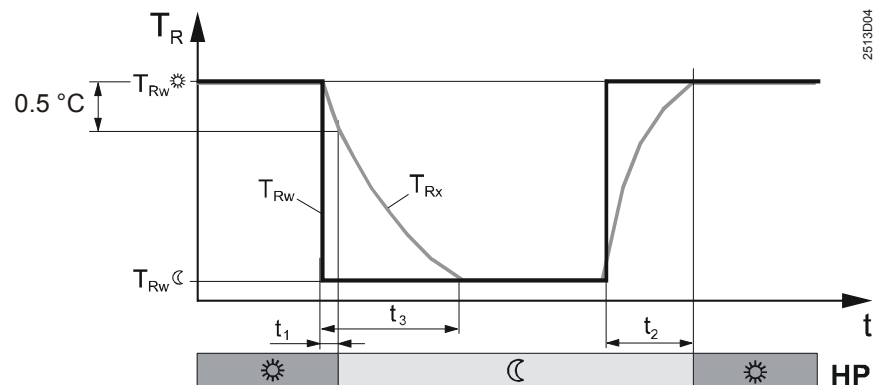

- HP Heating program
- T_R Room temperature
- t Time
- t_1 Forward shift for early shutdown
- t_2 Forward shift to start heating up
- t_3 Quick setback
- T_{Rw} Room temperature setpoint
- T_{Rw}^* Nominal room temperature setpoint
- T_{Rw}^{C} Reduced room temperature setpoint
- T_{Rx} Actual value of room temperature

12.10.4 Room model temperature

To ascertain the room temperature generated by the room model, a distinction must be made between 2 cases:

- RVD260 is not in quick setback mode:
The room temperature generated by the room model is identical to the current room temperature setpoint
- RVD260 is in quick setback mode:
The room temperature generated by the room model is determined according to the following formula:

$$\text{Room model temperature } T_{RM} = (T_{Rw}^* - T_{AM}) \times e^{-\frac{t}{3 \times kt}} + T_{AM} \quad [^{\circ}\text{C}]$$

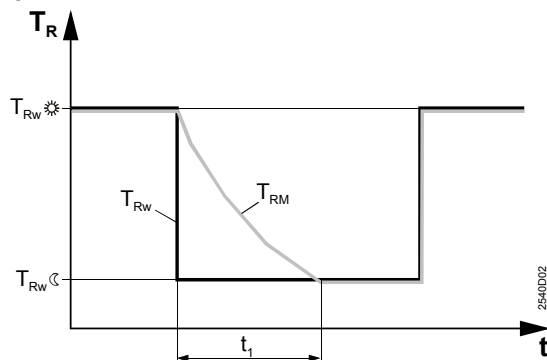

Progression of the room temperature generated by the room model

- e 2.71828 (basis of natural logarithms)
- k_t Building time constant
- t Time [h]
- t_1 Quick setback
- T_{AM} Composite outside temperature
- T_R Room temperature
- T_{RM} Room model temperature
- T_{Rw}^* Nominal room temperature setpoint
- T_{Rw}^{C} Reduced room temperature setpoint

12.10.5 Optimum stop control

During occupancy times, the RVD260 maintains the setpoint for NORMAL heating. Toward the end of the occupancy time, the control system switches to the setpoint for REDUCED heating. Optimization calculates the switchover time such that, at the end of the occupancy time, the room temperature will lie 0.5 °C below the setpoint for NORMAL heating (early shutdown).

When entering 0 hours for maximum early shutdown, optimum stop control is deactivated.

12.10.6 Quick setback

When switching from the normal temperature to a lower temperature level (REDUCED or holidays/frost), the heating is shut down. And it remains shut down until the setpoint of the lower temperature level is reached.

- When using a room sensor, the actual value of the room temperature is taken into account
 - Without room sensor, the actual value is simulated by the room model
- The duration of quick setback is determined according to the following formula:

$$t = 3 \times k_t \times \left(-\ln \frac{T_{Rw\text{☾}} - T_{AM}}{T_{Rw\text{☀}} - T_{AM}} \right)$$

ln	Natural logarithm
k_t	Building time constant [h]
t	Duration of quick setback [h]
T_{AM}	Composite outside temperature
$T_{Rw\text{☀}}$	Normal room temperature setpoint
$T_{Rw\text{☾}}$	Reduced room temperature setpoint

12.10.7 Optimum start control

During non-occupancy times, the RVD260 maintains the setpoint for REDUCED heating. Toward the end of the non-occupancy time, optimization switches the control system to the setpoint for NORMAL heating. Optimization calculates the switchover time such that, at the start of occupancy, the room temperature will have reached the setpoint for NORMAL heating.

When the room temperature is simulated by the room model – that is, without room sensor – the forward shift is calculated as follows:

$$t = (T_{Rw\text{☀}} - T_{RM}) \times 3 \times k_t$$

k_t	Building time constant [h]
t	Forward shift [min]
$T_{Rw\text{☀}}$	Normal room temperature setpoint
T_{RM}	Room model temperature

Optimum start control with the room model is performed only if, previously, quick setback took place.

Optimum start control can be deactivated by entering 0 hours as the maximum heating up time.

12.10.8 Maximum rate of flow temperature increase

Function

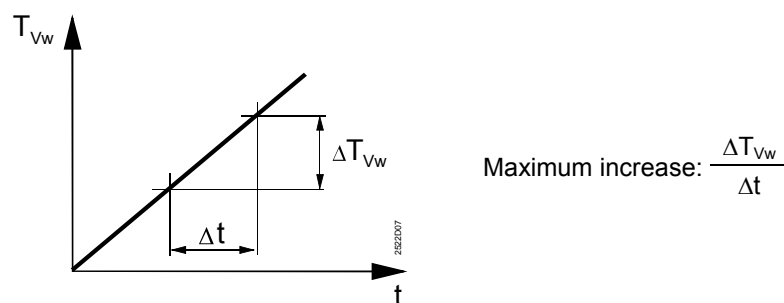

t	Time
Δt	Unit of time
T_{vw}	Flow temperature setpoint
ΔT_{vw}	Setpoint increase per unit of time

For each heating circuit, the rate of increase of the flow temperature setpoint can be separately limited to a maximum (“heating up brake”). In that case, the maximum rate of increase of the flow temperature setpoint is the set temperature per unit of time (°C/hour).

The function...

- prevents cracking noises in the piping,
- protects objects and construction materials that are sensitive to quick temperature increases (e.g. antiques),
- prevents excessive loads on heat generating equipment.

The limit value is to be set on operating line 77. The function can be deactivated using setting ---.

Impact on d.h.w. heating

Limitation of the rate of temperature increase has no impact on the d.h.w. circuit.

12.11 Frost protection for the building

12.11.1 General

Frost protection for the building acts separately on both heating circuits. It makes certain that the room temperature will not fall below a certain level. If the room temperature falls below the setpoint for frost protection, the controller maintains a room temperature equivalent to that setpoint plus the switching differential of 1 K.

Controller and heat generation must therefore be ready to operate (mains voltage present).

The setpoint for frost protection is to be set on the end-user level, operating line 3. This function cannot be deactivated.

12.11.2 Mode of operation with room sensor

The controller compares the room temperature with the adjusted setpoint for frost protection. If the room temperature falls below that setpoint, the controller activates the heating circuit pump to maintain the flow temperature at that setpoint plus the switching differential of 1 K.

When using a room sensor, frost protection for the building has priority over the automatic ECO function.

12.11.3 Mode of operation without room sensor

The controller continually determines the room temperature as a function of the flow temperature.

If the room temperature falls below the adjusted setpoint for frost protection, the controller activates the heating circuit pump and controls the flow temperature such that the room temperature will lie by the switching differential of 1 K above that setpoint.

Prerequisite is that the heating curve slope is correctly set.

Without room sensor, frost protection for the building has no priority over the automatic ECO function.

12.12 Other protection functions

The protection functions act on several function blocks.

12.12.1 Pump kick

The pump kick prevents the pumps from seizing.

The pump kick can be deactivated on operating line 146. If activated, it works in every operating mode; it is also performed when one of the heating circuit is in protection mode.

The pump kick function is activated for 30 seconds every Friday morning at 10:00.

If several pumps require kicking, they are activated one after the other in the order M1, M2, M3, M4, K6 and K7. The kicks are separated by pauses of 30 seconds. If, with the selected plant type, a certain pump is not present, the relevant kick is omitted.

The pump kick can be interrupted by heat source- or consumer-dependent signals.

In the case of plant types with a common flow and pump heating circuit, pump M1 is not kicked when d.h.w. is heated or when the respective overrun is still in progress. The pump kick will be performed later.

12.12.2 Valve kick

The valve kick function is activated every Friday after the pump kick.

The control outputs for the mixing valve actuators in the secondary circuits (heating circuits, d.h.w. circuit) are activated for 30 seconds one after the other; this means that the mixing valves opens. The control system then delivers the command for closing.

The kicks are separated by pauses of 30 seconds.

If there is a request for heat and the mixing valve is "busy", the valve kick is omitted.

2-port valves in the primary circuits are not kicked.

12.12.3 Shutdown of pump

The pump is shut down to provide protection against overtemperatures, separately in each heating circuit. The function is activated when, for the heating circuit, a maximum limit value for the flow temperature has been entered (operating line 95).

If the flow temperature exceeds the maximum limit value for the flow temperature by 7.5 °C, the pump in the heating circuit flow is shut down. It starts running again when the flow temperature drops below the limit value.

Shutdown of the pump is not a safety function!

12.12.4 Pump and mixing valve overrun

If, during overrun, there is a sudden drop in the demand for heat, the consumer/heat exchanger generates a forced signal to avoid the accumulation of heat. In segment 0, the forced signal is forwarded to all devices in all segments; in segments 1...14, to all devices contained in the relevant segment.

During overrun, consumers (heating circuits, d.h.w.) and heat exchanges respond to forced signals (bus or/and internally) as follows:

- If no forced signal is present, the consumers/heat exchangers perform normal pump overrun for the set overrun time
- If a forced signal is received, the consumers continue to draw heat from the heat source in the following manner:
 - In mixing circuits, the previous setpoint is maintained; during overrun, that setpoint appears on the display
 - In pump circuits, the pump continues to run. If, at the same time, an internal pump overrun is demanded, a maximum selection of the 2 overrun times is made; in that case, the longer overrun time applies

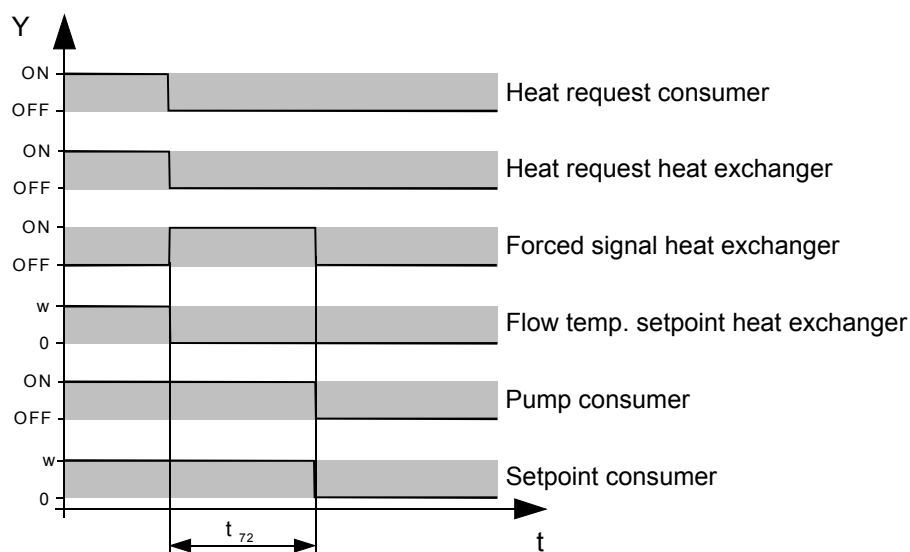

ON Switching on
 OFF Switching off
 t Time
 t_{72} Overrun time (operating line 72)
 w Setpoint
 Y Manipulated variable

Plant types 1–4 and 4–4 do not respond to forced signals since heat is drawn from the heat source only when d.h.w. is consumed.

If the forced signal drops out, the consumers/heat exchangers that have responded to the forced signal initiate the following actions:

- The valves are driven to their fully closed position
- The pumps continue to run for the set overrun time and then stop

D.h.w. discharging protection has priority over pump and mixing valve overrun.

13 Function block: Valve actuator heat exchanger

13.1 Operating lines

Function block "Valve actuator heat exchanger" provides settings for the heating engineer.

<i>Line</i>	<i>Function, parameter</i>	<i>Factory setting (range)</i>	<i>Unit</i>
81	Running time actuator heat exchanger	120 (10...873)	s
82	P-band heat exchanger control	35 (1...100)	K
83	Integral action time heat exchanger control	120 (10...873)	s
84	Setpoint boost heat exchanger	10 (0...50)	K
85	Maximum limitation flow temperature	--- (variable...140)	°C
86	Minimum limitation flow temperature	--- (8...variable)	°C
87	External heat demand	60 (0...100)	°C
88	Priority external heat demand	0 (0/1)	
89	Heat demand input DC 0...10 V	100 (5...130)	°C

13.2 Mode of operation

With plant types 2–x through 4–x, this function block controls the secondary flow temperature of the heat exchanger according to the temperature acquired by flow sensor B1.

- With plant types 2–x and 3–x, it is the heat exchanger that supplies heat to the heating circuits and the d.h.w. circuit via the common flow
 - With plant types 4–x, it is the heat exchanger that supplies heat to the heating circuits
- With all types of plant, 2-port valve Y1 in the heat exchanger's primary return is controlled.

This function block also provides minimum and maximum limitation of the flow temperature acquired by sensor B1.

13.3 Control process

If the current flow temperature deviates from the setpoint, 2-port valve Y1 offsets the deviation in a stepwise fashion. For that, the controller drives an electromotoric or electrohydraulic actuator. The ideal running time of the actuator is 2 to 3 minutes. The actuator's running time, the P-band and the integral action time are to be set on operating lines 81...83, depending on the type of plant. In addition, the heat exchanger's setpoint boost is adjustable.

13.4 Maximum limitation of flow temperature

The maximum limit value is to be set on operating line 85. The setting range for the maximum limit value reaches from the minimum limit (setting on operating line 86) to 140 °C.

At the limit value, the heating curve runs horizontally. This means that the flow temperature setpoint cannot exceed the maximum value.

This function can be deactivated (entry of --- on operating line 85).

Note:

Maximum limitation is not a safety function; for that purpose, a thermostat, thermal reset limit thermostat or similar must be installed!

13.5 Minimum limitation of flow temperature

The minimum limit value is to be set on operating line 86. The setting range for the minimum limit value reaches from 8 °C to the maximum limit (setting on operating line 85).

At the limit value, the heating curve runs horizontally. This means that the flow temperature setpoint cannot fall below the minimum value.

This function can be deactivated (entry of --- on operating line 86).

13.6 External heat demand at input H5

The RVD260 can receive heat demand signals via input H5 (heat demand indicated when contact makes).

For the extent of the external heat demand, a fixed value applies. This fixed value is the setpoint in °C and is to be set on operating line 87. Control is performed according to the temperature acquired by flow sensor B1.

- Plant type 1–x: Heating circuit pump of heating circuit 1. It is thus possible to provide manual remote control of the controller setpoint for heating circuit 1, for example
- Plant types 2–x, 3–x, and 4–x: 2-port valve of heat exchanger

The function can be deactivated by entering ---.

On operating line 88, it can be selected whether the external heat demand has absolute priority (setting 0) or whether a maximum selection is to be made between external and internal heat demand (setting 1).

13.7 External heat demand at input B71/U1

A heat demand signal can be fed to the controller via the DC 0...10 V voltage input U1.

On operating line 88, it can be decided whether a maximum selection is to be made between external and internal heat demand (setting 0) or whether the external heat demand is given absolute priority (setting 1).

The temperature value of the heat demand signal corresponding to DC 10 V is to be set on operating line 89. This request always acts on the flow temperature setpoint (B1). Relationship of voltage signal:

<i>Voltage</i>	<i>Temperature when operating line 89 = 80 °C</i>	<i>Temperature when operating line 89 = 130 °C</i>
DC 0 V	0 °C	0 °C
DC 5 V	40 °C	65 °C
DC 10 V	80 °C	130 °C

The controller interprets signals below DC 0.4 V as "No request".

14 Function block: Valve actuator space heating

14.1 Operating lines

Function block "Valve actuator space heating" provides settings for the heating engineer.

<i>Line</i>	<i>Function, parameter</i>	<i>Factory setting (range)</i>	<i>Unit</i>
91	Actuator running time heating circuit	120 (10...873)	s
92	P-band heating circuit control	35 (1...100)	K
93	Integral action time heating circuit control	120 (10...873)	s
94	Setpoint boost mixing valve/heat exchanger	10 (0...50)	K
95	Maximum limitation flow temperature	--- (variable...140)	°C
96	Minimum limitation flow temperature	--- (8...variable)	°C

14.2 Mode of operation

This function block controls the secondary flow temperature of the heating circuits equipped with a valve. Depending on the type of plant, this is:

<i>Plant type</i>	<i>Impact on heating circuit 1</i>	<i>Impact on heating circuit 2</i>
All 1-x	Control of valve Y1 according to sensor B1	Control of valve Y7 according to sensor B12
2-0, 2-1, 2-6	No valve present	Control of valve Y5 according to sensor B12
2-2, all 4-x	No valve present	Control of valve Y7 according to sensor B12
All 3-x	Control of valve Y5 according to sensor B12	Control of valve Y7 according to sensor B3

In addition, the function block provides minimum and maximum limitation of the flow temperature in the controlled heating circuit.

14.3 Control process

If the current flow temperature deviates from the setpoint, the mixing valve offsets the deviation in a stepwise fashion. For that, the controller drives an electromotoric or electrohydraulic actuator. The ideal running time of the actuator is 2 to 3 minutes.

The actuator's running time, the P-band and the integral action time are to be set on operating lines 91...83, depending on the type of plant. In addition, the heat exchanger's or mixing valve's setpoint boost is adjustable.

14.4 Maximum limitation flow temperature

The maximum limit value is to be set on operating line 95. The setting range for the maximum limit value reaches from the minimum limit (setting on operating line 96) to 140 °C.

At the limit value, the heating curve runs horizontally. This means that the flow temperature setpoint cannot exceed the maximum value. The function can be deactivated (entry of --- on operating line 95).

When setting the maximum limit value, protection against overtemperature is activated (refer to chapter 12.12.3 "Shutdown of pump")

Note:

Maximum limitation is not a safety function; for that purpose, a thermostat, thermal reset limit thermostat or similar must be installed!

14.5 Minimum limitation of flow temperature

The minimum limit value is to be set on operating line 96. The setting range for the minimum limit value reaches from 8 °C to the maximum limit (setting on operating line 95). The function can be deactivated (entry of --- on operating line 96). At the limit value, the heating curve runs horizontally. This means that the flow temperature setpoint cannot fall below the minimum value.

15 Function block: D.h.w. heating/legionella function

This function block contains all **settings** required for the general d.h.w. functions. Not included here and described in separate function blocks are:

- The d.h.w. setpoints: Can be set by the end-user on operating lines 41 and 42
- Parameters for control of the actuators
- Parameters on the locking functions level
- Parameters for d.h.w. heating via solar collector or electric immersion heater

The details of the different types of d.h.w. heating (with coil type storage tank, directly via heat exchanger, or with stratification storage tank) are described below.

15.1 Operating lines

<i>Line</i>	<i>Function, parameter</i>	<i>Factory setting (range)</i>	<i>Unit</i>
98	D.h.w. temperature sensor	0 (0...2)	
99	D.h.w. charging	0 (0...3)	
101	Release of d.h.w. heating	0 (0...2)	
102	Release of circulating pump	1 (0...2)	
103	Switching differential d.h.w.	5 (1...20)	K
104	Legionella function	6 (---/1...7, 1-7)	
105	Setpoint legionella function	65 (60...95)	°C
106	D.h.w. priority	4 (0...4)	
107	Overrun time intermediate circuit pump	4 (0...40)	min
108	Extra overrun time charging pump	60 (10...2400)	s
109	Maximum period d.h.w. charging	150 (---/5...250)	min
110	Protection against discharging during overrun of d.h.w. pump	0 (0/1)	

The kind of acquisition of storage tank temperature is to be selected on operating line 98 and the kind of d.h.w. charging on operating line 99.

15.2 Release of d.h.w. charging

The release of d.h.w. charging can be selected on operating line 101, depending on the type of plant:

- For the release of d.h.w. charging, 3 choices are available:

<i>Setting</i>	<i>Release</i>
0	D.h.w. charging is always released (24-hour program)
1	Release takes place according to the heating program per heating circuit entered on operating lines 6 through 12 and the controllers defined on operating line 125 (refer to chapter 17 "Function block: Assignment of d.h.w." For that, a "maximum selection" is made; d.h.w. charging is released as long as one of the heating circuits operates in a heating period. In any case, the start of the first release period is always shifted forward by the time set on operating line 109 (maximum time)
2	Release takes place according to the d.h.w. program entered on operating lines 17 through 23

- Release means that the d.h.w. is heated up to the nominal setpoint (operating line 41)
- At the end of the release period, the nominal d.h.w. setpoint changes to the reduced setpoint. (operating line 42)
- In the case of direct d.h.w. heating via heat exchanger, operating line 109 is deactivated

- The release of d.h.w. charging is not dependent on the operating level of space heating

15.3 Control of circulating pump

The function block controls a circulating pump, if installed. The pump is optional, irrespective of the type of plant. Operation of the circulating pump prevents the d.h.w. piping system from cooling down.

The settings available for release of the circulating pump on operating line 102 are the following:

Setting	Release
0	Circulating pump is always released (24 hours a day)
1	Release takes place according to the heating circuit programs for both heating circuits entered on operating lines 6 through 12. For that, a "maximum selection" is made; the pump is released as long as one of the heating circuits operates in a heating period. There is no forward shift.
2	Release takes place according to the d.h.w. program entered on operating lines 17 through 23

On operating line 120, it can be selected whether or not the control output shall be deactivated during d.h.w. charging:

Setting	Release
0	OFF during d.h.w. charging
1	ON during d.h.w. charging

If the circulating pump is assigned to 1 or several heating programs, it immediately starts running when a heating period begins. If, according to the d.h.w. assignment, all heat consumers are in holiday mode, the circulating pump is deactivated. For more detailed information, refer to chapter 17 "Function block: Assignment of d.h.w." Speed control of the circulating pump is not possible.

15.4 Switching differential of d.h.w. control

D.h.w. charging is switched off when the d.h.w. temperature reaches its setpoint. It is switched on again when the d.h.w. temperature falls by the switching differential below the setpoint. The switching differential is to be set on operating line 103. It only acts with the plant types that use a storage tank.

15.5 Legionella function

The parts of the legionella function described below are contained in the d.h.w. function block. The most important aspects of the legionella function are covered by chapter 18 "Function block: Extra legionella functions".

15.5.1 Weekday for legionella function

Operating line 104 is used to set whether and on which weekday the legionella function shall be activated.

The legionella function can be started when the nominal d.h.w. setpoint applies (button for d.h.w. heating lit and no holiday period active). The function is deactivated when the frost level is reached.

The legionella function can be aborted by pressing the button for d.h.w. heating.

15.5.2 Setpoint for legionella function

The setting range for the legionella setpoint is 60...95 °C (operating line 105). When using storage tanks with 2 sensors, the d.h.w. temperature must reach the setpoint at both sensors.

15.6 Priority of d.h.w. charging

15.6.1 General

Depending on the heat output available, it may be practical to restrict the amount of heat delivered to the heating circuits during d.h.w. charging. In this case, d.h.w. heating is given priority over space heating. On operating line 106, the controller offers 3 types of priority:

- Absolute priority
- Shifting priority
- No priority (parallel operation)

Priority (absolute or shifting) is made possible through generation of an uncritical locking signal. It is generated when d.h.w. is heated up. Since plant types x-4 do not use a storage tank, the flow switch detects when d.h.w. is heated.

If no flow switch is installed, a locking signal is generated whenever there is a valid request for d.h.w.

The impact of the locking signals on the heating circuits/heat exchangers is described in chapter 20.3 "Locking signals".

15.6.2 Absolute priority

Introduction

During d.h.w. charging, the heating circuits are locked, which means that no heat is supplied to them.

Setting on operating line 106 = 0

Controllers without LPB link

During d.h.w. heating, the controller generates an internal uncritical locking signal of 100 % (fixed value) and sends it to its own consumers.

Controllers with LPB link

In addition to the behavior without LPB link as described above, the controller signals its primary controller or heat source (consumer master from which it receives heat) via bus that it currently effects d.h.w. charging with absolute priority. This consumer master then sends an uncritical locking signal of 100% (fixed value) via bus to all controllers in the same segment. If the consumer master is located in segment 0, the locking signal is sent to all controllers in the interconnected system.

The RVD260 has no consumer master functionality.

If a consumer master is not available, absolute priority is the same as that with a controller without LPB link.

15.6.3 Shifting priority

General

During d.h.w. heating, the amount of heat supplied to the heating circuits is throttled should charging lead to a shortage of heat. Generation of the valid flow temperature setpoint can be selected via operating line 106:

- 1 = flow temperature setpoint is determined by the request for d.h.w.
- 2 = flow temperature setpoint is determined by a maximum selection of the valid requests for d.h.w.

Controllers without LPB link

In the case of shifting priority, the controller is able to generate and send a controller-internal uncritical locking signal in the range of 0...100% to its own consumers if the capacity for d.h.w. charging is no longer sufficient.

- With plant types x-3, x-8 and x-9, the differential of flow temperature setpoint and actual flow temperature is integrated for generating a locking signal corresponding to the integral value
- With plant type x-4, the maximum return temperature and actual value of the return temperature from the return sensor are used, since there is neither a flow temperature setpoint nor an actual value of the flow temperature. If there is no return sensor, it is not possible to have shifting priority and no locking signal is generated
- With plant types x-1, x-2 and x-6, the differential of flow temperature setpoint and actual flow temperature of the internal heat exchanger is integrated for generating a locking signal corresponding to the integral value

Controllers with LPB link

In addition to the behavior without LPB link described above and with all plant types, the controller signals its primary controller or heat source (consumer master from which it receives heat) via bus that it currently effects d.h.w. charging with shifting priority. If, now, the boiler is not able to maintain its setpoint, the differential of setpoint and actual value is integrated and an integral-dependent uncritical locking signal in the range 0...100% is generated.

- If the consumer master is located in segment 0, the locking signal is sent to all controllers in the interconnected system
- If the consumer master is not located in segment 0, the locking signal is only sent to all controllers in the same segment like the controller that calls for d.h.w.

The RVD260 has no consumer master functionality.

If a consumer master is not available, shifting priority works the same way as with a controller without LPB link.

15.6.4 No priority

No priority means parallel operation. D.h.w. charging has no impact on the heating circuits. The heat consumers are not restricted.

In a pump heating circuit, it can occur that too hot water is fed to the heating circuit; caution must be exercised especially in the case of floor heating systems (refer to chapter 15.10.7 "Protection against overtemperature"). By contrast, a mixing heating circuit is able to reduce the flow temperature by adding colder return water.

Generation of the valid flow temperature setpoint can be selected via operating line 106:

- 3 = flow temperature setpoint is determined by the request for d.h.w.
- 4 = the flow temperature setpoint is determined by maximum selection of the valid requests. With plant types no. 1-x and 4-x, setting "Maximum selection" is inactive

15.7 Pump overrun

15.7.1 General

To prevent the accumulation of heat, it is possible to select overrun of the intermediate circuit pump and of the storage tank charging pump, depending on the type of plant. The type of priority has no impact on the overrun function. By contrast, pump overrun can be interrupted by d.h.w. discharging protection, or extended by forced signals. Simultaneous overrun of heating circuit pumps and d.h.w. pumps is permitted.

15.7.2 Intermediate circuit pump

The overrun time can be set on operating line 107. The function can be deactivated by using a setting of 0 minutes.

The d.h.w. intermediate circuit pump overruns for an adjustable period of time if, previously, d.h.w. charging took place.



15.7.3 Storage tank charging pump

For the storage tank charging pump, an additional overrun time can be set on operating line 108. This overrun time is added to the overrun time of the intermediate circuit pump. The pump overrun times are the same when using a setting of 0 seconds. On applications with intermediate or mixing circuit, the storage tank charging pump stops with no overrun if the d.h.w. flow temperature at B1 or B3 falls below the current storage tank temperature.

15.8 Frost protection for d.h.w.

The d.h.w. circuit is protected against frost. Frost protection for the d.h.w. is activated when the d.h.w. temperature drops below 5 °C, independent of the operating mode. The charging pump is activated and the d.h.w. temperature is maintained at a level of at least 5 °C.

Frost protection is ensured when...

- d.h.w. heating is on (operating mode button  lit),
- when d.h.w. heating is off (operating mode button  dark),
- the holiday function is active in one of the heating circuits (operating mode button  flashes).

With all plant types x-4, frost protection for d.h.w. is not possible.

15.9 Switching d.h.w. heating off

The d.h.w. functions can be deactivated by pressing button "D.h.w. heating ON/OFF" (button's LED not lit). Frost protection for d.h.w. remains active; the d.h.w. pump(s) is (are) deactivated.

Manual d.h.w. charging will be finished, however.

Button "D.h.w. heating ON/OFF" has no impact on d.h.w. heating via the solar collector.

15.10 D.h.w. heating with storage tanks

15.10.1 General

The RVD260 supports the following types of plant:

- Plants with coil type storage tanks where the heating circuit and d.h.w. heating use a **common** heat exchanger
- Plants with stratification storage tanks where the heating circuit and d.h.w. heating use 2 separate heat exchangers

Space heating and d.h.w. heating use a pump or mixing heating circuit. The heat for storage tank charging is delivered by an intermediate circuit pump. Exceptions are plant types 1–3 and x–8.

The way the d.h.w. storage tank temperature is acquired is to be selected on operating line 98. In the case of plants without solar d.h.w. heating, setting 0 is required.

The storage tank temperature can be acquired as follows:

- Automatically (with 1 or 2 sensors)
- Solar d.h.w. heating with 1 or 2 sensors. If, in addition, sensor B72 and 1 of the 2 multifunctional relays is appropriately parameterized, function "Solar d.h.w. charging" is activated

The switch-on and switch-off temperature for charging are calculated as follows:

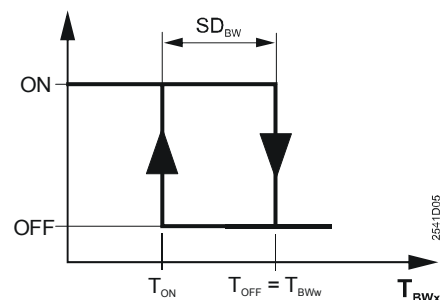

ON	D.h.w. charging ON
OFF	D.h.w. charging OFF
SD_{BW}	Switching differential of d.h.w. charging
T_{ON}	Switch-on temperature
T_{OFF}	Switch-off temperature
T_{BWw}	D.h.w. temperature setpoint
T_{BWx}	D.h.w. temperature
T_{BWx1}	Measured value storage tank sensor 1 (B31)
T_{BWx2}	Measured value storage tank sensor 2 (B32)

Definition of switch-on temperature (start of d.h.w. charging):

Operating line 98	Acquisition	Switching criterion
0 (automatically)	1 sensor	$T_{BWx1} < (T_{BWw} - SD_{BW})$
0 (automatically)	2 sensors	$T_{BWx1} < (T_{BWw} - SD_{BW})$ and $T_{BWx2} < (T_{BWw} - SD_{BW})$
1	1 sensor with solar	$T_{BWx1} < (T_{BWw} - SD_{BW})$
2	2 sensors with solar	$T_{BWx1} < (T_{BWw} - SD_{BW})$ and $T_{BWx2} < (T_{BWw} - SD_{BW})$

Definition of switch-off temperature (end of d.h.w. charging):

Operating line 98	Acquisition	Switching criterion
0 (automatically)	1 sensor	$T_{BWx1} > T_{BWw}$
0 (automatically)	2 sensors	$T_{BWx1} > T_{BWw}$ and $T_{BWx2} > T_{BWw}$
1	1 sensors with solar	$T_{BWx1} > T_{BWw}$
2	2 sensors with solar	$T_{BWx1} > T_{BWw}$ and $T_{BWx2} > T_{BWw}$

From the 2 tables above, it is obvious that when using 2 sensors, it is irrelevant which of the 2 sensors is fitted at the top and which at the bottom of the d.h.w. storage tank.

15.10.2 D.h.w. charging

The kind of d.h.w. charging is to be selected via operating line 99.

- Charging by heating:
When selecting 0 on operating line 99, the d.h.w. storage tank is charged exclusively via the heating system throughout the year
- Charging in changeover mode:
When selecting 1, 2 or 3 on operating line 99, the d.h.w. storage tank is charged via the heating system in the winter and by the electric immersion heater in the summer

The change from charging via the heating system to the electric immersion heater takes place when there is no demand for space heating for at least 48 hours (changeover at midnight).

The change from the electric immersion heater to charging via the heating system is effected as soon as there is a request for heat from space heating. Depending on the setting made on operating line 99 (1, 2 or 3), different types of heat requests are considered for the changeover criterion:

<i>Operating line 99</i>	<i>Criterion for changeover</i>
1	Request for heat from the controller's own heating circuit
2	Requests for heat from all controllers connected to the data bus (LPB) having the same segment number , including those from the controller's own heating circuit
3	Requests for heat from all controllers connected to the data bus (LPB), including those from the controller's own heating circuit

15.10.3 Maximum charging time

The duration of d.h.w. charging can be limited to ensure the heating circuit will also receive sufficient heat when d.h.w. heating cannot be finished. The setting is to be made on operating line 109. If a maximum time is not desired, the function can be deactivated (setting ---).

When the maximum d.h.w. charging time is reached, d.h.w. heating is subsequently locked for the same period of time.

In the case of parallel priority, the maximum d.h.w. charging time is inactive.

15.10.4 Manual storage tank charging

Manual storage tank charging (also termed d.h.w. push) is triggered by pressing the operating mode button for d.h.w. heating  for 3 seconds. It also triggers d.h.w. charging when...

- d.h.w. charging is not released,
- the d.h.w. temperature lies within the switching differential (also refer to forced charging),
- the d.h.w. operating mode is on protection (holidays, d.h.w. heating off).

Operating mode "D.h.w. heating ON" is switched on by activating manual d.h.w. charging; as an acknowledgement, the LED in the operating mode button flashes for 3 seconds. Manual storage tank charging cannot be aborted. It is ended when the required d.h.w. temperature is reached or when the maximum d.h.w. heating time has elapsed.

If, after manual storage tank charging, d.h.w. heating shall return to protection mode, operating mode button  must be pressed again.

Manual storage tank charging can be triggered via M-bus or LPB and passed on via LPB (refer to chapter 22.5 "Load management").

15.10.5 Forced charging

In the case of forced charging, the storage tank is also charged when the d.h.w. temperature does not drop below the switching differential.

This takes place depending on the program selected via operating line 101:

- Daily at the beginning of the first release period (release according to the d.h.w. program or according to the heating program), **or**
- Daily at midnight if d.h.w. heating is always released (24-hour program).

Forced charging is switched off when the d.h.w. setpoint is reached.

This function can be activated or deactivated via operating line 243 (function block "Miscellaneous"):

0 = function deactivated

1 = function activated

15.10.6 Protection against discharging

With the types of plant having a storage tank connected on the secondary side (coil type or stratification storage tank, plant types 2-x and 3-1), protection against d.h.w. discharging is provided **during pump overrun**.

If the common flow temperature or the flow temperature in the intermediate circuit is lower than the d.h.w. temperature (in the case of 2 storage tank sensors, the lower actual value applies), overrun of the d.h.w. pump in the intermediate circuit is aborted prematurely. This prevents the d.h.w. from cooling down unnecessarily.

On operating line 110, protection against discharging during overrun of the d.h.w. pump can be activated (0 = no protection, 1 = protection against discharging active).

With plant types using a coil type storage tank, it is recommended to have protection against discharging always activated. This applies to plant types 1-9, 2-1, 2-2, 3-1 and 4-9.

Plant type 2-6 with a storage tank charging pump provide protection against d.h.w. discharging **during charging**. This deactivates the storage tank charging pump when flow temperature B1 falls by 2 K below the storage tank temperature. When using 2 storage tank sensors, the higher actual value applies.

With plant types x-8 and x-9 with a storage tank connected on the primary side, protection against discharging is not required during charging.

15.10.7 Protection against overtemperature

If the flow temperature is too high, the heating circuit pump will overrun before d.h.w. charging is started.

15.10.8 Storage tank with electric immersion heater

If an electric immersion heater is installed, it heats the d.h.w. as soon as the heating system switches to summer operation. Changeover is to set on operating line 99 (refer to chapter 15.10.2 "D.h.w. charging").

During the summer, the electric immersion heater is released for 24 hours a day. The following conditions lock the electric immersion heater in summer operation:

- Holidays active
- D.h.w. heating switched off
- External contact of QAW70 room unit active

Manual d.h.w. charging and the legionella function are not possible during the time the electric immersion heater is on.

The function is activated as soon as 1 of the 2 multifunctional relays in chapter 19 "Function block: Multifunctional relays" and changeover are appropriately parameterized.

If a storage tank uses an electric immersion heater, the setpoint adjustment is no longer valid since in that case, the thermostat of the electric immersion heater ensures temperature control of the storage tank.

15.11 D.h.w. heating with stratification storage tank

This chapter only covers the functions used in addition to d.h.w. heating with storage tanks.

15.11.1 General

D.h.w. heating with stratification storage tanks is covered by plant types 1–8, 2–6 and 4–8. With these types of plant, separate heat exchangers are used for space heating and d.h.w. heating. They can be connected either parallel to or in series with the heating circuit.

The d.h.w. flow temperature can be controlled with 1 or 2 flow sensors; speed control of the storage tank charging pump is possible also.

A flow switch is not required for these types of plant.

15.11.2 D.h.w. heating

The d.h.w. flow temperature is acquired by sensor B3 at the secondary output of the heat exchanger.

If the d.h.w. temperature at storage tank sensor B31 or B32 drops, d.h.w. heating starts in that both the intermediate circuit pump and the storage tank charging pump are activated.

With plant type 2–6 with intermediate circuit, the storage tank charging pump is activated only when the common flow temperature at B1 exceeds the actual d.h.w. temperature by at least 2 K. It stops without overrun when the temperature drops below the current d.h.w. temperature.

D.h.w. heating is ended when the d.h.w. temperature setpoint is reached. Both the intermediate circuit pump and the storage tank charging pump operate during the defined pump overrun times, the storage tank charging pump by an adjustable period of time longer than the intermediate circuit pump (operating lines 107 and 108).

But both d.h.w. charging and pump overrun can be stopped by protection against discharging.

15.11.3 Feeding the circulating water into the heat exchanger

Feeding circulating water into the heat exchanger is configurable (operating line 55).

The following settings can be made:

<i>Setting</i>	<i>Circulating pump</i>	<i>Feeding the circulating water into...</i>	<i>Function, action</i>
0	No	–	No control
1	Yes	the storage tank	No control, no compensation of heat losses
2	Yes	the heat exchanger	80% of the heat losses are compensated
3	Yes	the heat exchanger	Full compensation of heat losses; constantly striving to reach the d.h.w. flow temperature setpoint

Setting 2:

A flow temperature drop of 20% is tolerated. The behavior is the same as that with d.h.w. heating directly via heat exchanger (setting on operating line 55 = 2). When d.h.w. charging is finished, the circulation circuit is first charged for 5 minutes before the request for d.h.w. heating becomes invalid.

15.12 Direct d.h.w. heating

15.12.1 General

Direct d.h.w. heating via heat exchanger is covered by plant types x–4. With these types of plant, separate parallel connected heat exchangers are used for the heating circuit and the d.h.w. circuit. This category also includes combi heat exchangers.

15.12.2 D.h.w. heating

D.h.w. heating takes place directly via heat exchanger, which can have a flow switch fitted on the secondary side. A circulating pump can be used as an option. The relevant settings are to be made on operating lines 55 and 56.

Regulating unit is always 2-port valve Y5 in the primary return of the d.h.w. heat exchanger; it is controlled according to the temperature at B3 in the secondary flow of the heat exchanger.

To ensure good control performance, a fast actuator with a running time of 10...35 seconds should be used; its opening and closing times may differ. For operating lines, settings and further explanations, refer to chapter 16 "Function block: Valve actuator d.h.w.".

15.12.3 Protection against cooling down

General

Protection against cooling down is available with plant types featuring direct d.h.w. heating (x–4 and x-8). It is used to prevent the primary side of the d.h.w. heat exchanger from cooling down.

There is a risk of cooling down (leading to long waiting times when d.h.w. is needed) when, during longer periods of time,...

- no heat is required for space heating, **and**
- there is no d.h.w. consumption.

Prerequisites

Protection against cooling down is only active in d.h.w. heating mode (d.h.w. release given, holiday function not active).

Adjustable on operating line 244 is the waiting time, that is, the period of time between 2 valve opening actions. Default settings:

- Opening time: 30 seconds
- Stroke: 25%
- Switch-off temperature (only if sensor is present); it lies 5 °C below the d.h.w. setpoint

Mode of operation

Depending on the type of plant, the temperature for protection against cooling down is acquired as follows:

- Plant type 1–4: With return sensor B71 in the primary d.h.w. return
- Plant type 4–4: With return sensor B72 in the primary d.h.w. return

This means that only 1 sensor is required for maximum limitation of the return temperature and protection against cooling down. But the function can also be provided without sensor.

Cooling down is prevented by primary valve Y5 in the primary d.h.w. return, which opens at regular intervals based on fixed settings.

This takes place when...

- during the waiting time, there was no demand for heat (neither from the heating circuit nor from d.h.w.),
- the waiting time since the valve opened last has elapsed.

Protection against cooling down closes the valve again:

- Without sensor: At the end of the opening time
- With sensor: When the return temperature lies above the switch-off temperature, or after 4 minutes

The function is aborted prematurely when...

- the flow switch delivers a signal, or
- when there is a request for heat, either from the heating circuit or the d.h.w. circuit.

If desired, protection against cooling down can be deactivated (entry --- on operating line 244).

15.12.4 Siting the sensors

The correct location of the sensors is extremely important. If there is no flow switch, it must be made certain that the flow sensor immerses into the heat exchanger.

Caution

If the flow sensor is not correctly sited, **there is a risk of excessive heat exchanger temperatures**. With these types of plant, d.h.w. can always be heated, but the circulating pump runs only when released!

15.12.5 Flow switch

A flow switch can be fitted in the heat exchanger's cold water return. For this purpose, the RVD260 provides digital input H5, which is to be configured on operating line 56. The flow switch improves the control performance in connection with the heat exchanger. When flow is indicated, the control system can expect a demand for heat. When there is no more flow, it can be ensured that the d.h.w. fed to the tap will not be too hot.

The use of a flow switch is especially recommended in the case of smaller plants (single-family houses, etc.).

Fault status supervision is not possible since short-circuits and interruptions are permitted states.

Functions dependent on the flow switch are the adjustable load limit (refer to chapter 16.7) and the child-proofing facility (refer to chapter 16.7.3).

15.12.6 Compensation of heat losses

Generally, the control system ensures that d.h.w. temperature drops due to consumption are always compensated for.

In addition, when using a flow switch and a circulating pump, it can be configured whether the control shall also be active when there is no d.h.w. consumption, that is, whether heat losses due to radiation, circulation, etc., shall be compensated for.

The configuration is to be made via operating line 55.

If a flow switch is installed, the primary valve is temporarily controlled by an opening signal at the beginning of d.h.w. consumption, and by a closing signal at the end of d.h.w. consumption.

Caution

To ensure that excessive temperatures do not occur and that the response of the control system is fast, a QAE212... immersion sensor is required in the case of configurations with no flow switch, since that sensor immerses into the heat exchanger.

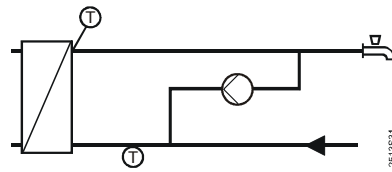

Plant without flow switch

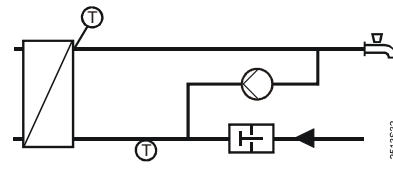

Plant with flow switch

Operating line		Function, compensation of heat losses	Flow switch	Circulating pump
56	55			
≠ 4	0	Full compensation	No	No
	1, 2, 3	Full compensation	No	Yes
4	0, 1	No compensation	Yes	No
4	2	Partial compensation, flow temperature drop up to 20% permitted	Yes	Yes
4	3	Full compensation	Yes	Yes

Explanations relating to the settings on operating line 55:

- Settings 0 and 1:
No d.h.w. heating when there is no consumption. This is also the case when the circulating pump runs. Since heat losses are not compensated for, the d.h.w. temperature eventually drops to the room temperature level
- Setting 2:
A temporary drop of the d.h.w. flow temperature is tolerated. Heat losses are only partly compensated for; the flow temperature may drop by a maximum of 20%. Subsequent heating up to the d.h.w. setpoint always takes a minimum of 5 minutes. For the compensation of heat losses, the circulating pump must be released. If not released, there will be **no** control, independent of the d.h.w. flow temperature

Example:

D.h.w. setpoint $T_{BWW} = 50 \text{ °C}$

Cold water temperature $T_{Nx} = 10 \text{ °C}$ (fixed value):

Permissible drop $\Delta T = 20\%$

Minimum d.h.w. flow temperature $T_{BwV} = ?$

$$T_{BwV} = T_{BWW} - \Delta T \times (T_{BWW} - T_{Nx}) = 50 - 0.2 (50 - 10) = 42 \text{ °C}$$

- Setting 3:
Striving to reach the d.h.w. setpoint, all heat losses are fully compensated for. A circulating pump is installed

15.12.7 Cold water sensor

Cold water sensor B32 is fitted downstream from the mixing point of cold water return and circulation return. It must be located as close as possible to the mixing point. The sensor detects temperature changes on the cold water side, which are then considered by flow temperature control. This improves considerably the control performance.

16 Function block: Valve actuator d.h.w.

16.1 Operating lines

Function block "Valve actuator d.h.w." provides settings for the heating engineer.

<i>Line</i>	<i>Function, parameter</i>	<i>Factory setting (range)</i>	<i>Unit</i>
111	Opening time actuator in the d.h.w. circuit	35 (10...873)	s
112	Closing time actuator in the d.h.w. circuit	35 (10...873)	s
113	P-band d.h.w. control	35.0 (1.0...100.0)	K
114	Integral action time d.h.w. control	35 (10...873)	s
115	Derivative action time d.h.w. control	16 (0...255)	s
116	Setpoint boost d.h.w. charging	16 (0...50)	K
117	Maximum setpoint d.h.w. temperature	65 (20...95)	°C
118	Setpoint boost mixing valve/heat exchanger d.h.w.	10 (0...50)	K
119	Reduction d.h.w. setpoint for storage tank sensor at the bottom	5 (0...20)	K
120	Circulating pump during d.h.w. charging	0 (0/1)	
124	Load limit for actuation of flow switch	25 (0...60)	%

16.2 Mode of operation

This function block provides d.h.w. temperature control with a mixing valve or 2-port valve. The sensor and the type of actuating device required depend on the type of plant:

<i>Plant type</i>	<i>Sensor</i>	<i>Actuating device</i>	<i>Location of sensor and regulating unit</i>
1–3	B71	Valve Y5	Primary return of d.h.w. heat exchanger
2–2	B3	Mixing valve Y5	D.h.w. flow (intermediate circuit)
1–4, 1–8, 1–9, 4–x	B3	Valve Y5	

16.3 Control process

If the flow temperature deviates from the setpoint, the 2-port or mixing valve is adjusted in a stepwise fashion to compensate for the deviation (with plant type 1–3, this can also be accomplished with 2-position control). For that, the controller drives an electromotoric or electrohydraulic actuator.

The ideal running time of the actuator is 10...35 seconds. The actuator's opening and closing times are separately adjustable, thus ensuring that actuators with asymmetric running times can also be used.

To enhance the control performance, the derivative action time (D-part of PID control) can be adjusted, in addition to the P-band and the integral action time.

If, with plant type 1–3, no return sensor B71 is used, the function block operates as a 2-position controller. When there is a demand for heat, 2-port valve Y5 is fully opened; with no demand for heat, it is fully closed. This takes place independent of whether or not maximum limitation of the d.h.w. return temperature is activated.

16.4 Setpoint boosts

Setpoint boost ensures that the flow temperature required by the consumer to perform its function (control) is delivered by the heat source.

16.4.1 Charging boost

Charging boost for the d.h.w. setpoint can be set on operating line 116. This is the difference of heat request to the heating medium (setpoint) and setpoint of the d.h.w. in the storage tank.

16.4.2 Flow temperature boost

The boost for the mixing valve or the heat exchanger in the d.h.w. circuit can be set on operating line 118. In the case of direct d.h.w. heating via heat exchanger (plant types x-4), the charging boost is to be set on the same operating line because the heat exchanger is an external one.

16.5 Maximum setpoint for d.h.w. temperature

On operating line 117, the maximum d.h.w. setpoint that can be set via operating line 41 is defined.

Depending on the type of plant, the setting range of operating line 41 is as follows:

<i>Plant type</i>	<i>Minimum setting value</i>	<i>Maximum setting value</i>
1-3, 1-9, 2-1, 2-2, 3-1, 4-9	Reduced setpoint (setting operating line 42)	Minimum selection from: <ul style="list-style-type: none">• Setting value on operating line 117• Sum of setting values on operating lines 116 and 231 (maximum limit value of return temperature with d.h.w. charging)
1-4, 1-8, 2-6, 4-4, 4-8	Reduced setpoint (setting operating line 42)	Setting value on operating line 117

In any case, the setting range is limited to a maximum of 95 °C.

16.6 D.h.w. charging with 2 storage tank sensors

With the plant types using a storage tank, the storage tank temperature can be acquired by 1 or 2 sensors (B31 and B32).

When using 2 storage tank sensors, the amount by which the setpoint of the colder storage tank sensor is lower than that of the warmer sensor can be set on operating line 119.

For the switch-off and switch-on criteria required for d.h.w. charging, refer to chapter 15.10.

The "reduced setpoint" for the colder sensor allows the secondary return temperature to be kept low until the end of d.h.w. charging is reached, in spite of mixing in the stratification tank. The d.h.w. switching differential still applies.

16.7 Adjustable load limit

16.7.1 Adjustment to the season

To enable the controller to provide stable d.h.w. temperature control also when connection conditions vary (summer/winter operation), it must adjust the running time. This adjustment is made via the **current maximum stroke**.

When the plant is switched on, the assumption is made that the maximum stroke is 50%. If the controller opens the actuator by more than 50%, the stroke model constantly adjusts the current maximum stroke "toward 100%". At midnight, the current maximum stroke is reduced by 1%. If the plant is not in use for a longer period of time, the minimum stroke is 20%.

16.7.2 Load limit

Mode of operation

The flow switch delivers fast information, independent of the d.h.w. flow sensor. This ensures that the entire amount of heat on the heat exchanger's secondary side is exchanged before control of the primary valve is passed to d.h.w. control.

When d.h.w. consumption starts, the flow switch opens primary valve Y5 for a certain period of time, independent of the flow temperature. This opening time can be set with the load limit setting on operating line 124. The setting is to be made as a percentage of the maximum stroke.

Calculation of setting value

Normally, in summer operation, the valve opening required for 100% load is about 80%. This percentage is termed **design point** and must be included in the calculation. The load limit can be calculated according to the following formula:

$$\text{Load limit} = \frac{\text{Heat exchanger volume}_{\text{secondary}}}{\varnothing \text{ D.h.w. consumption} \times \text{opening time} \times \text{design point}}$$

Example:

Calculation of the load limit to be set for a heat exchanger with the following characteristics:

Water content on the secondary side	= 1.0 liter
Average d.h.w. consumption	= 0.14 liters/second
Opening time of d.h.w. actuator	= 35 seconds
Design point	= 80% (0.8)

$$\text{Load limit} = \frac{1,0}{0,14 \times 35 \times 0,8} * 100 = 25\%$$

The calculated load limit is used as a guide value which can vary, depending on the plant's hydraulic layout. It is recommended to start with the calculated load limit and then...

- decrease the value if the d.h.w. flow temperature significantly overshoots after d.h.w. consumption,
- increase the value if the d.h.w. flow temperature significantly undershoots.

When the load limit is reached, the control system takes on control of the actuator on the primary side.

The end of d.h.w. consumption is also detected by the flow switch, and actuator Y1 on the primary side is overridden by a CLOSE signal.

16.7.3 Child-proofing

If the d.h.w. tap is repeatedly opened (e.g. by children playing with the tap), the child-proofing function prevents the load limit function from being effected more often than necessary, thus preventing excessive d.h.w. temperatures.

If, within 10 seconds, the d.h.w. tap is opened more than twice, the controller provides d.h.w. heating **without** support of the load limit function.

17 Function block: Assignment of d.h.w.

17.1 Operating line

Function block "Assignment of d.h.w." provides a setting for the heating engineer.

<i>Line</i>	<i>Function, parameter</i>	<i>Factory setting (range)</i>	<i>Unit</i>
125	Assignment d.h.w. charging	0 (0...2)	

17.2 Assignment d.h.w. charging

Operating line 125 is used to select for which controllers in an LPB system the d.h.w. is provided or, in other words, which heating circuits get their d.h.w. from the same source.

With plant types x-0, this setting is not required since they provide no d.h.w. heating.

<i>Setting operating line 125</i>	<i>Explanation</i>
0	D.h.w. is only provided for the controller's own heating circuit
1	D.h.w. is only provided for the heating circuits of the controllers with the same segment number connected to the data bus (LPB)
2	D.h.w. is provided for all heating circuits of the controllers connected to the data bus (LPB)

The setting is active only when setting 1 (according to heating program, with forward shift) was selected on operating line 101 (release of d.h.w. heating).

18 Function block: Extra legionella functions

In d.h.w. systems with storage tank, the legionella function prevents the growth of legionella viruses. This is accomplished by raising the d.h.w. temperature at a certain interval.

18.1 Operating lines

<i>Line</i>	<i>Function, parameter</i>	<i>Factory setting (range)</i>	<i>Unit</i>
104	Legionella function	6 (---/1...7/1-7)	
105	Setpoint legionella function	65 (60...95)	°C
126	Starting point legionella function	--:-- (--:--/00:00...23:50)	hh:mm
127	Dwelling time at legionella setpoint	--- (---/10...360)	min
128	Operation of circulating pump during legionella function	1 (0/1)	
235	Maximum setpoint of return temperature during d.h.w. heating to the legionella setpoint	--- (---/0...140)	°C

18.1.1 Legionella function

Operating line 104 is used to set whether and on which weekday the legionella function shall be activated.

The legionella function can be started when the nominal d.h.w. setpoint applies (button for d.h.w. heating lit and no holiday period active). The function is deactivated when the frost level is reached.

The legionella function can be aborted by pressing the button for d.h.w. heating.

18.1.2 Setpoint

The setting range for the legionella setpoint is 60...95 °C (operating line 105). When using storage tanks with 2 sensors, the d.h.w. temperature must reach the setpoint at both sensors.

18.1.3 Time

The legionella function is started at the set time. If no time is parameterized (operating line 126 = --:--), the legionella function is started the first time d.h.w. is heated to the normal setpoint.

If the legionella function cannot be performed at the set time because d.h.w. heating has been deactivated (button for d.h.w. heating, holidays), it will be effected later as soon as d.h.w. heating is released again.

In the case of direct d.h.w. heating with flow switch, the legionella function is activated at the set time though, but the legionella viruses will only be killed the next time d.h.w is consumed.

18.1.4 Dwelling time

The legionella setpoint must be maintained with no interruption for at least the set dwelling time.

If the lower storage tank temperature lies above the legionella setpoint minus 1 K, the legionella function is considered fulfilled and the dwelling time elapses.

If the storage tank temperature drops by more than $SD + 2$ K (switching differential plus 2 K) below the legionella setpoint before the dwelling time has elapsed, the dwelling time must be started again.

If no dwelling time is set (operating line 127 = ---), the legionella function is performed the moment the legionella setpoint is reached.

In the case of direct d.h.w. heating without circulating pump, the set value has no impact (no dwelling time).

18.1.5 Operation of circulating pump

During the time the legionella function is performed, the circulating pump can be forced to operate. This function ensures that hot water also circulates through the plant's hot water distribution system. The setting (0 or 1) is to be made on operating line 128.

If the lower storage tank temperature exceeds the legionella setpoint minus 1 K, the circulating pump is forced to operate.

If the storage tank temperature drops by more than $SD + 2\text{ K}$ (switching differential plus 2 K) below the legionella setpoint, the circulating pump is not activated anymore.

18.1.6 Maximum limitation of return temperature

Refer to chapter 27.2.3 "Maximum limitation in d.h.w. heating mode".

18.2 Mode of operation

Preconditions for the legionella function to be performed:

- The storage tank temperature is acquired by 1 or 2 sensors (legionella function with thermostats is not possible)
- The legionella function has been parameterized (operating line 104)
- D.h.w. heating is on (button  lit)
- The holiday function is not active

If the 2 criteria...

- set day and

time are satisfied, the legionella function is released. Release of the legionella function means that the d.h.w. temperature setpoint is raised to the level of the legionella setpoint and that forced charging is triggered. If d.h.w. heating is off or the holiday function is active, the legionella function is released. When the end of the overriding function is reached, d.h.w. charging to the legionella setpoint is started since the legionella function is still released.

The following graph shows the behavior of the legionella function depending on the d.h.w. temperature.

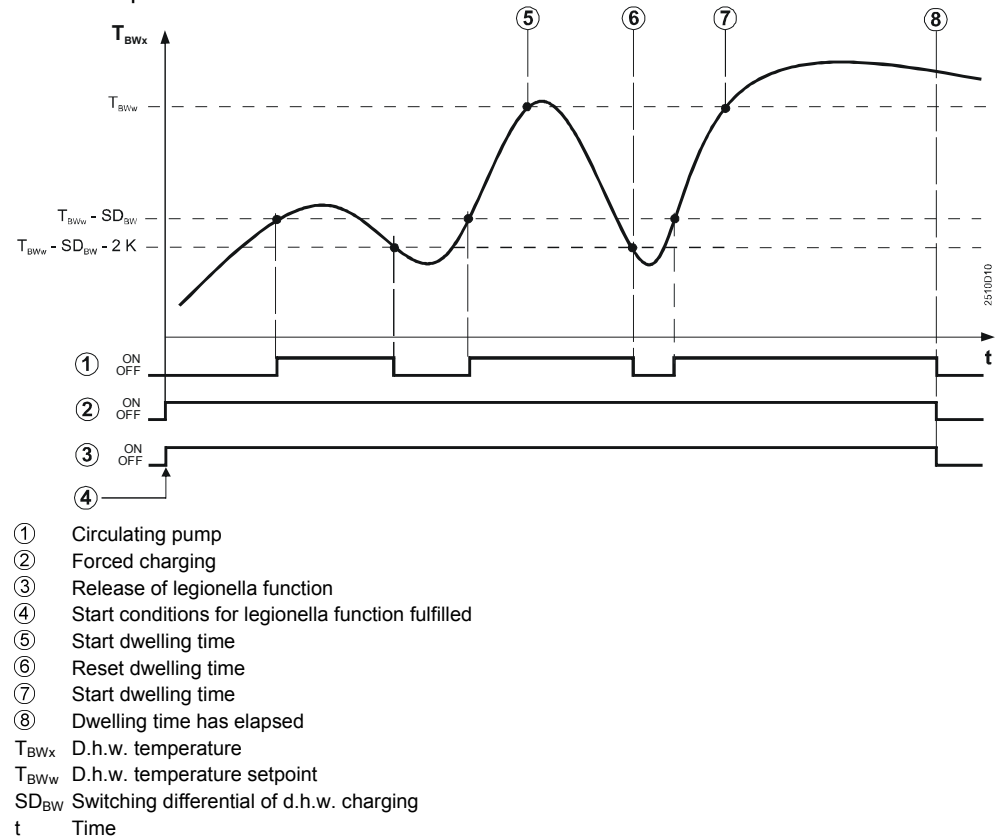

If set, a maximum d.h.w. charging time is also active here. If the legionella setpoint is not reached, the legionella function is interrupted and resumed on completion of the maximum charging time.

The maximum setpoint of the d.h.w. temperature has no impact on the legionella setpoint.

19 Function block: Multifunctional relays

19.1 Operating lines

Function block "Multifunctional relays" provides settings for the heating engineer.

<i>Line</i>	<i>Function, parameter</i>	<i>Factory setting (range)</i>	<i>Unit</i>
129	Function multifunctional relay K6	0 (0...5)	
130	Function multifunctional relay K7	0 (0...5)	

19.2 Mode of operation and settings

Function block "Multifunctional relays" enables further optional functions to be parameterized on operating lines 129 and 130, depending on the type of plant. Both multifunctional relays can be parameterized independently:

<i>Setting</i>	<i>Function</i>	<i>For details, refer to...</i>
0	No function	–
1	Refill function	Chapter 26
2	Electric immersion heater	15.10.8
3	Collector pump	25
4	Circulating pump	11.2.5
5	Flow alarm	21.4

Caution

Wrong configurations will not be prevented!

20 Function block: LPB parameters

20.1 Operating lines

Function block "LPB parameters" provides settings for the heating engineer.

<i>Line</i>	<i>Function, parameter</i>	<i>Factory setting (range)</i>	<i>Unit</i>
131	Device number for bus address	0 (0...16)	
132	Segment number for bus address	0 (0...14)	
133	Clock mode	0 (0...3)	
134	Bus power supply, operating mode and status indication	A (A/0/1)	
135	Outside temperature source	A (A/00.01...14.16)	
136	Locking signal gain	100 (0...200)	%
137	Response to uncritical locking signals from data bus	1 (0/1)	

20.2 LPB parameters

20.2.1 Addressing the devices

Every device connected to the data bus (LPB) requires an address. This address is comprised of device number (1...16, operating line 131) and segment number (0...14, operating line 132).

In an interconnected plant, every address may be assigned only once. If this is not observed, the correct functioning of the entire connected plant cannot be ensured. In that case, an error message is delivered (error code 82).

If the controller operates autonomously (with no bus), both device number and segment number must be set to zero.

Since the device address is also associated with control processes, it is not possible to use all possible device addresses with all types of plant:

If an inadmissible address has been entered for the selected plant type, an error message is delivered (error code 140).

For detailed information about addressing devices, refer to Data Sheet N2030 (Basic System Data).

20.2.2 Source of time of day

Several sources are available for the time of day, depending on the master clock. The source is to be entered for the controller on operating line 133, as a digit (setting 0...3):

0 = autonomous clock in the RVD260

1 = time of day via bus; clock (slave) without remote readjustment

2 = time of day via bus; clock (slave) with remote readjustment

3 = time of day on the bus; central clock (master)

The individual settings have the following impact:

<i>Setting</i>	<i>Impact</i>	<i>Diagram</i>
0	<ul style="list-style-type: none"> Time of day on the controller can be readjusted The controller's time of day is not matched to the system time 	
1	<ul style="list-style-type: none"> Time of day on the controller cannot be readjusted The controller's time of day is continually and automatically matched to the system time 	

2	<ul style="list-style-type: none"> Time of day on the controller can be readjusted and, at the same time, readjusts the system time since the change is adopted by the master The controller's time of day is nevertheless automatically and continually matched to the system time 	
3	<ul style="list-style-type: none"> Time of day on the controller can be readjusted, which also changes the system time The controller's time of day is used for the system 	

Only one controller per system may be used as the master. If several controllers are parameterized as masters, an error message is delivered (error code 100).

20.2.3 Bus power supply

In interconnected plants with a maximum of 16 controllers, bus power supply may be decentralized, that is, power may be supplied via each connected device. If a plant contains more than 16 devices, central bus power supply is mandatory.

On each connected device, it is then necessary to select whether the data bus is powered centrally or decentrally by each controller.

With the RVD260, this selection is to be made on operating line 134. The current selection is shown on the left and the current bus power supply state on the right.

<i>Display</i>	<i>Automatic bus power supply via controller</i>	<i>Bus power supply currently available</i>
0 0	Off, central bus power supply required; no power supply via controller	No
0 1		Yes
A 0	On, decentral bus power supply via controller	No
A 1		Yes

The word BUS appears on the display only when the bus address is valid and when bus power supply is available. This means the display indicates whether or not data traffic via data bus is possible.

20.2.4 Outside temperature source

If, in interconnected plants, the outside temperature is adopted from the data bus, the temperature source can be addressed either automatically or directly (operating line 135).

<i>Addressing</i>	<i>Display, entry</i>	<i>Explanation</i>
Automatically	A ss.gg	xx = segment number gg = device number
Directly	ss.gg	To be entered is the address of the outside temperature source

If the controller operates autonomously (without bus), there is no display and no entry can be made.

If the controller is used in an interconnected plant **and** if it has its own outside sensor, it is not possible to enter an address (if an entry is made, the display shows OFF). In that case, the controller always uses the outside temperature signal sent by its own sensor. The address displayed is its own.

For detailed information about addressing the source, refer to Data Sheet N2030 (Basic System Data).

20.3 Locking signals

20.3.1 Basics

The following functions use locking signals and send them to the heat exchangers and consumers:

- Minimum limitation of boiler return temperature
- Protective boiler startup
- D.h.w. priority

With the heat exchanger and consumer controllers, it can be set on operating line 136 (locking signal gain) to what degree they shall respond to a locking signal. The locking signal gain can be adjusted between 0 and 200%.

For heat exchangers and consumers using 3-position control, following applies:

<i>Setting operating line 136</i>	<i>Response</i>
0%	Locking signals are ignored
100%	Locking signals are adopted as they are
200%	Locking signals are adopted and doubled

For consumers using 2-position control, following applies:

<i>Setting operating line 136</i>	<i>Response</i>
0%	Locking signals are ignored
>0%	Locking signals are adopted as they are

There are 2 types of locking signals:

- Uncritical locking signals
- Critical locking signals

20.4 Critical locking signals

Critical locking signals are generated by the boiler controller during protective boiler startup or during minimum limitation of the boiler return temperature, aimed at throttling the consumers, thus enabling them to leave the crucial range more quickly.

If the boiler controller is located in segment 0, the critical locking signal is sent to all heat exchangers and consumers in the bus system.

If the boiler controller is located in segment 1...14, it only sends the locking signal to all heat exchangers and consumers in its own segment.

- Heat exchangers and consumers using 3-position control lower their control setpoint depending on the magnitude of the locking signal and the setting "Locking signal gain". For that, the pump is not deactivated
- Consumers using 2-position control deactivate the pump at a defined locking signal value if setting "Locking signal gain" is >0%. The switch-off point is independent of setting "Locking signal gain"

The RVD260 cannot generate critical locking signals since it is not a boiler controller.

Plant type x-4 (direct d.h.w. heating) is the only consumer that **never** responds to critical locking signals.

20.5 Uncritical locking signals

20.5.1 General

Uncritical locking signals are generated in connection with d.h.w. priority (absolute and shifting) and only act on the heating circuits and heat exchangers.

There are...

- "Controller-internal locking signals", and
- "Locking signals from the data bus (LPB)".

For more detailed information, refer to chapter 15.6 "Priority of d.h.w. charging"

The uncritical locking signal has no impact on all heat exchangers that lie in the supply chain of the priority-demanding d.h.w.

Whether the controller shall respond to uncritical locking signal from the data bus can be selected via operating line 137 (response to uncritical locking signals from data bus). This setting has no impact on the response to controller-internal locking signals.

<i>Setting operating line 137</i>	<i>Response</i>
0	Uncritical locking signals from data bus are ignored
1	Uncritical locking signals from data bus are adopted

20.5.2 Controller-internal uncritical locking signals

Controller-internal uncritical locking signals always throttle the heating circuits.

- With plant type 4-x, the heat exchanger operating parallel to d.h.w. is impacted

20.5.3 Uncritical locking signals from data bus

Uncritical locking signals from data bus throttle the heat exchangers and the heating circuits.

21 Function block: Device functions

21.1 Operating lines

Function block "Device functions" provides settings for the heating engineer.

<i>Line</i>	<i>Function, parameter</i>	<i>Factory setting (range)</i>	<i>Unit</i>
141	Pulse lock actuator	1 (0/1)	
142	Frost protection for the plant	1 (0/1)	
143	Flow alarm	--:-- (--:--/0:10...10:00)	h
144	Changeover winter-/summertime	25.03 (01.01...31.12)	dd.mm
145	Changeover summer-/wintertime	25.10 (01.01...31.12)	dd.mm
146	Pump kick	1 (0/1)	

21.2 Pulse lock for actuators

This function acts on all 3-position actuators controlled by the RVD260.

If, during a total period of time equaling 5 times the running time, an actuator has received opening or closing pulses, additional pulses in the same direction are suppressed by the controller.

For safety reasons, the controller delivers a 1-minute pulse in the respective direction to the actuator at 10-minute intervals.

A pulse in the opposite direction negates the pulse lock.

This function acts on all actuators used in the plant and is intended to reduce the wear on the relay contacts and to extend the life of the actuators. It can be deactivated on operating line 141 (setting = 0).

21.3 Frost protection for the plant

21.3.1 Principle

Frost protection for the plant protects both heating circuits against freeze-ups by activating the respective heating circuit pump. Controller and heat generation must therefore be ready to operate (mains voltage present).

Frost protection for the plant can be provided with or without outside sensor. The switching differential is 1 K (fixed value). Frost protection is always active, also...

- when the control system is off (protection mode),
- during quick setback,
- during OFF by ECO.

If required, frost protection for the plant can be deactivated (setting on operating line 142 = 0).

In addition to frost protection for the plant through activation of the heating circuit pump, frost protection for the heating circuit flow becomes active as well.

21.3.2 Mode of operation with outside sensor

Frost protection for the plant operates in 2 stages:

1. If the outside temperature falls below 1.5 °C, the heating circuit pump is activated for 10 minutes at 6-hour intervals.
2. If the outside temperature falls below -5 °C, the heating circuit pump is activated and runs continuously.

When active, the respective frost protection stage is switched off when the outside temperature exceeds the limit value by the switching differential of 1 K.

21.3.3 Mode of operation without outside sensor

Frost protection for the plant operates in 2 stages:

1. If the flow temperature (sensor B1) falls below 10 °C, the heating circuit pump is activated for 10 minutes at 6-hour intervals.
2. If the flow temperature falls below 5 °C, the heating circuit pump is activated and runs continuously.

When active, the respective frost protection stage is switched off when the flow temperature exceeds the limit value by the switching differential of 1 K.

21.3.4 Frost protection for heating circuit flow

In addition to frost protection for the plant, frost protection acts separately on both heating circuits through activation of the heating circuit pumps. This is single stage frost protection and is activated when the heating circuit flow drops below 5 °C. The switching differential is 2 K; switching off takes place at >7 °C. Frost protection for the heating circuit flow generates a request for heat (flow temperature setpoint) of 10 °C and, after reaching the switching-off criterion, remains active for a minimum of 5 minutes.

21.4 Flow alarm

21.4.1 Heating circuit and d.h.w. circuit with storage tanks

This function is used to track bottlenecks in the heat supply from the district heating network.

The flow alarm leads to an error message when the flow temperature in...

- one or both heating circuits,
- the common flow, or
- in the d.h.w. circuit

does not reach the setpoint band (setpoint \pm switching differential of 3 K) within a defined period of time when there is a request for heat. This period of time can be set on operating line 143.

The flow alarm becomes inactive when the setpoint band is reached.

The flow alarm appears on the display as ERROR and, on operating line 50, with an error code.

The correlation between sensor, plant type and error code in the heating circuit control systems is the following:

<i>Heating circuit control</i>	<i>Sensor / controlling element per plant type</i>				<i>Error code</i>
	<i>1-x</i>	<i>2-x</i>	<i>3-x</i>	<i>4-x</i>	
Common flow		B1/Y1	B1/Y1	B1/Y1	120
Heating circuit 1	B1/Y1		B12/Y5		121
Heating circuit 2	B12/Y7	2-0, 2-1, 2-6: 2-2:	B12/Y1 B12/Y7	B3/Y7 B12/Y7	122

The following table applies to d.h.w. heating:

<i>Plant type</i>	<i>Sensor/controlling element</i>	<i>Error code</i>
1-8, 1-9, 2-2, 4-8, 4-9	B3/Y5	123
2-6	B3/no mixing valve	123

Plant type 1-3 has no flow alarm since there is no flow sensor in the d.h.w. circuit.

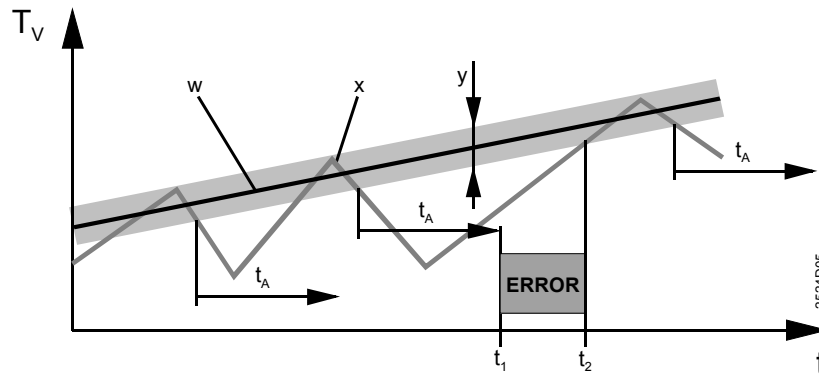

Flow alarm

t	Time	T_V	Flow temperature
t_1	Start of ERROR display	w	Setpoint
t_2	End of ERROR display	x	Actual value
t_A	Waiting time (set on operating line 143)	y	Setpoint band

- At t_1 , an error message is delivered; during the time t_A (set on operating line 143), the actual value stayed below setpoint band y
- At t_2 , the error message is reset; actual value x reached setpoint band y

The flow alarm can be deactivated by entering --:--.

Caution

When the flow alarm function is activated, any return or return temperature differential sensors (if installed) may not be used for display purposes since they are evaluated in the monitoring process.

21.4.2 Direct d.h.w. heating via heat exchanger

Monitoring overtemperature

With plant types x-4, this function is required to track faults on the primary valve and primary actuator – faults that may represent risks to the user. Hence, this function is **not** used to check the performance of d.h.w. control, but to monitor overtemperature! The function is activated when the d.h.w. temperature exceeds the current d.h.w. setpoint by 10 K for a period of 20 seconds.

The flow alarm appears on the display as ERROR and, on operating line 50, with error code 123.

In addition, relay Kx (K6, K7) is energized; it can thus be used to switch on a monitoring device, for instance. For parameterizing 1 of the 2 multifunctional relays for the flow alarm, refer to chapter 19 "Function block: Multifunctional relays".

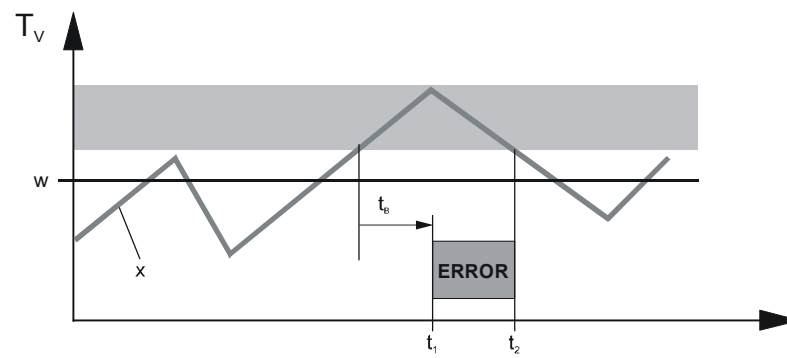

Flow alarm for monitoring overtemperature

t	Time	T_V	Flow temperature
t_1	Start of ERROR display	w	Setpoint
t_2	End of ERROR display	x	Actual value
t_B	Waiting time (20 seconds)		"Prohibited" range

Monitoring undertemperature

With plant types x-4, this function is required to track bottlenecks in the heat supply from the district heating network. Monitoring of undertemperature triggers an error message when, during a request for heat, the flow temperature falls by more than 10 K below its setpoint for a defined period of time. This period of time can be set on operating line 143. The flow alarm becomes inactive as soon as the limit is exceeded again.

Flow alarm for monitoring undertemperature:

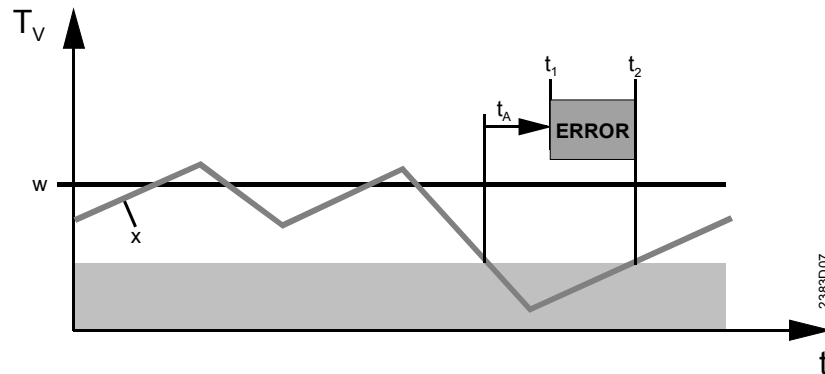

t	Time	T_V	Flow temperature
t_1	Start of ERROR display	w	Setpoint
t_2	End of ERROR display	x	Actual value
t_A	Waiting time (set on operating line 143)	■	"Prohibited" range

The flow alarm appears on the display as ERROR and, on operating line 50, with error code 123.

The flow alarm can be deactivated by entering --:--.

21.5 Changeover winter-/summertime

The change from wintertime to summertime, and vice versa, is made automatically. If international regulations change, the relevant changeover dates can be entered on operating lines 144 and 145. The date to be entered is the earliest possible changeover date. Changeover always takes place on a Sunday.

Example:

If the start of summertime is specified as the "Last Sunday in March", the earliest possible changeover date is March 25. The date to be entered on operating line 144 is then 25.03.

If no summer-/wintertime changeover is desired, the 2 dates to be set must coincide.

21.6 Pump kick

The pump kick function can be activated or deactivated via operating line 146 (refer to chapter 12.12.1 "Pump kick").

21.7 Speed-controlled pump

The speed-controlled pump can be parameterized on operating lines 147...149 (refer to chapter 11.2.7 "Speed-controlled pump").

22 Function block: M-bus parameters

22.1 Operating lines

Function block "M-bus parameters" provides settings for the heating engineer.

<i>Line</i>	<i>Function</i>	<i>Factory setting (range)</i>	<i>Unit</i>
151	M-bus primary address	0 (0...250)	
152	M-bus secondary address	Display function	
153	Baud rate	2400 (300...9600)	Baud
154	Forwarding of M-bus power control signals (load management)	0 (0...4)	
155	M-bus power control in the heating circuit (load management)	Display function	

22.2 General

The M-bus conforming to EN 1434-3 serves for reading setpoints and actual values. Also, individual user values can be written by the management system. Controller parameter settings via M-bus from a remote location are not possible.

22.3 Addressing and identification

Addressing on the M-bus consists of a primary and a secondary address. The default primary address is 0; the serial number is to be entered as the secondary address. Both parts of the address can be altered via M-bus, the primary address via operating line 151.

22.4 Baud rate

The baud rates available on operating line 153 are the following: 300, 600, 1200, 2400, 4800, and 9600 baud.

22.5 Load management

22.5.1 Load management of d.h.w.

With load management of d.h.w., other d.h.w. setpoints for the controller can be preset via M-bus. This makes sense when too much or too little heat is made available by the district heat connection.

When entering 0...4 on the M-bus master, the controller responds as follows:

<i>Setting</i>	<i>Response of controller</i>
0	Load management deactivated
1	Forced charging brings the d.h.w. to the nominal temperature setpoint
2	Forced charging brings the d.h.w. to the legionella setpoint
3	The current d.h.w. setpoint is the reduced setpoint
4	The current d.h.w. setpoint is the d.h.w. setpoint for frost protection

22.5.2 Load management of heating system

Load management of the heating system uses internal locking signals or acts on the request for heat (refer to relevant sections) to decrease or increase heat consumption. The validity of the request for heat is not influenced. The compensating variable is not influenced either since load management is a short-term intervention.

22.5.3 Resetting the load management signals

The controller clears all load management commands 2 hours after activation, if they have not already been canceled via M-bus.
In general, a load management command is not reset when a setpoint is reached; this means that the command applies not only once, but during the entire duration of the intervention.

22.5.4 Forwarding signals via LPB

On operating line 154, it is possible to define whether the load control signals received via M-bus shall be used only locally or, additionally, shall be passed on via LPB in the segment or in the entire interconnected system.

Meaning:

<i>Setting</i>	<i>Use</i>
0	Only locally
1	In the same LPB segment
2	Throughout the LPB system

Caution

- When sending the signals in the LPB segment, **no** other device in that segment may be connected to the M-bus!
- When sending the signals throughout the LPB system, **no** other device in the entire LPB system may be connected to the M-bus!

22.5.5 Resolution of M-bus signals

<i>Signal</i>	<i>Resolution</i>
Water temperatures	1.0 °C
Air temperatures	0.1 °C
Voltage at DC 0...10 V input	0.1 V

23 Function block: PPS parameters

This function block defines the devices and actions at the PPS. The RVD260 is the master; the connected devices (max. 2) are slaves.

23.1 Operating lines

<i>Line</i>	<i>Function, parameter</i>	<i>Factory setting (range)</i>	<i>Unit</i>
158	Impact of room unit functions on the heating circuits when using 1 room unit	0 (0...5)	

23.2 Impact of room unit on the heating circuits

If only 1 room unit is connected to the PPS, its actions on the 2 heating circuits must be defined:

<i>Room unit functions</i>	<i>Settings</i>					
	<i>0</i>	<i>1</i>	<i>2</i>	<i>3</i>	<i>4</i>	<i>5</i>
Current room temperature of the room unit acts on flow temperature control in heating circuit(s) ...	1	1	2	2	1 and 2	1 and 2
Display of flow temperature of heating circuit ...	1	1	2	2	1	1
Switching program, presence button in automatic operation and setpoint adjustments of room unit act on heating circuit(s) ...	1	1	2	2	1	1
Operating mode, presence button in continuous operation and holiday program of the room unit act on heating circuit(s) ...	1	1 and 2	2	1 and 2	1	1 and 2

24 Function block: Test and display

24.1 Operating lines

Function block "Test and display" provides settings and displays for the heating engineer.

<i>Line</i>	<i>Function, parameter</i>	<i>Factory setting (range)</i>	<i>Unit</i>
161	Sensor test	0 (0...11)	
162	Display of setpoint	0 (0...11)	
163	Relay test	0 (0...11)	
164	Speed of controlled pump	Display function	
165	Test of digital input	Display function	
169	Display of active limitations	Display function	
170	Software version	Display function	

24.2 Sensor test

The sensor test includes display of the temperature acquired by each sensor and the voltage at the analog input. The query is made by pressing buttons \leftarrow and \rightarrow .

Meaning:

--- = interruption/no sensor installed

ooo = short-circuit

To identify the acquired variable, a code is used.

<i>Code</i>	<i>Input</i>	<i>Sensor</i>
0	B9	Outside sensor
1	B1	Flow sensor
2	B3	Flow sensor
3	A6	Room unit sensor, heating circuit 1
4	A6	Room unit sensor, heating circuit 2
5	B7/U2	Primary return, primary pressure
6	B71/U1	Primary/secondary return, secondary pressure
7	B72	Primary/secondary return, collector sensor
8	B31	D.h.w. storage tank sensor
9	B32	D.h.w. storage tank sensor, return sensor
10	B12	Flow sensor
11	U1	DC 0...10 V/0...130 °C

24.3 Setpoint test

The setpoint test includes display of the setpoint assigned to each sensor. The query is made by pressing buttons \leftarrow and \rightarrow . To identify the acquired variable, a code is used. Display of --- means that no setpoint is available.

<i>Code</i>	<i>Input</i>	<i>Setpoint for ...</i>
0	B9	composite outside temperature
1	B1	flow sensor
2	B3	Flow sensor
3	A6	room unit sensor, heating circuit 1
4	A6	room unit sensor, heating circuit 2
5	B7/U2	primary return, primary pressure
6	B71/U1	primary/secondary return, secondary pressure
7	B72	primary/secondary return, collector sensor
8	B31	d.h.w. storage tank sensor
9	B32	d.h.w. storage tank sensor, return sensor
10	B12	flow sensor
11	---	

Using the line selection buttons \triangle and ∇ , it is possible to switch from the sensor test to the setpoint test, and vice versa; in that case, the selected code is maintained.

24.4 Relay test

The relay test is made to manually energize each relay contained in the RVD260 in order to check its state. The relays are energized by pressing buttons \triangleleft and \triangleright . Each relay is assigned a code:

Code	Response or current state
0	Normal operation (no test)
1	All relays deenergized
2	Relay at terminal Y1 energized
3	Relay at terminal Y2 energized
4	Relay at terminal K6 energized
5	Relay at terminal Q1 energized
6	Relay at terminal Q3 energized
7	Relay at terminal Y5 energized
8	Relay at terminal Y6 energized
9	Relay at terminal Q2 energized
10	Relay at terminal Y7/Q4 energized
11	Relay at terminal Y8/K7 energized

Caution

Before making the relay test, always close the main valve!

The relay test is ended as follows:

- Select another operating line, or
- Press one of the operating mode buttons, or
- Switch to manual control, or
- Automatically after 8 minutes.

24.5 Display of pump speed

The display is made on operating line 164; the speed of the pump selected on operating line 58 is given as a percentage of the nominal speed.

24.6 Display of digital input

Operating line 165 provides information about the digital input.

Input H5

Digital input H5 is able to receive pulses. Such pulses can be, for instance:

- Heat requests
- Signals from an alarm contact
- Pulses from the flow switch

The current state of the contact can be queried:

0 = contact open

1 = contact closed

The display shows **H5** and **0** or **1**.

Pulses

If input H5 receives pulses (e.g. from heat meters for limiting the volumetric flow), the number of pulses received per minute are displayed.

The display shows the number of pulses per minute. The measuring range is 0...2250 pulses/min. Only integral pulse values are displayed.

24.7 Limitations

Active limitations are displayed on operating line 169. The query is made by pressing buttons \leftarrow and \rightarrow . Every limitation is assigned a code and the respective limitation symbol.

Code	Symbol	Type of limitation	Limited variable
1		Maximum	Volumetric flow or output primary controller
2		Maximum	Common primary return
3		Maximum	Return temperature differential (DRT) precontrolled flow
4		Maximum	Common secondary flow
5		Maximum	Volumetric flow or output heating circuits
6		Maximum	Primary return heating circuit 1
7		Maximum	Secondary return heating circuit 1
8		Maximum	Temperature differential (DRT) heating circuit 1
9		Maximum	Secondary flow heating circuit 1
10		Maximum	Room temperature heating circuit 1
11		Maximum	Flow temperature rise heating circuit 1
12		Maximum	Primary return heating circuit 2
13		Maximum	Secondary return heating circuit 2
14		Maximum	Return temperature differential (DRT) heating circuit 2
15		Maximum	Secondary flow heating circuit 2
16		Maximum	Room temperature heating circuit 2
17		Maximum	Flow temperature rise heating circuit 2
18		Maximum	Primary return d.h.w.
19		Maximum	Secondary return d.h.w.
20		Maximum	Storage tank charging temperature
21		Maximum	Maximum storage tank temperature
22		Maximum	Evaporation temperature of heat conducting medium
23		Maximum	Overtemperature protection for collector
24		Minimum	Common flow primary side
25		Minimum	Common secondary flow
26		Minimum	Volumetric flow heating circuit 1
27		Minimum	Secondary flow heating circuit 1
28		Minimum	Reduced room temperature setpoint heating circuit 1
29		Minimum	Volumetric flow heating circuit 2
30		Minimum	Secondary flow heating circuit 2
31		Minimum	Reduced room temperature setpoint heating circuit 2

In general: The maximum limit function is activated when the respective temperature request (not the actual value!) exceeds the limit value.

24.8 Software version

The software version can be displayed on operating line 170. It is important for service engineers when making fault diagnoses.

25 Function block: Solar d.h.w.

25.1 Operating lines

Function block "Solar d.h.w." provides settings for the heating engineer.

Line	Function, parameter	Factory setting (range)	Unit
201	Temperature differential solar ON	8 (0...40)	K
202	Temperature differential solar OFF	4 (0...40)	K
203	Frost protection temperature for collector	--- (---/-20...5)	°C
204	Overtemperature protection for collector	105 (---/30...240)	°C
205	Evaporation temperature of heat conducting medium	140 (---/60...240)	°C
206	Maximum limitation of charging temperature	80 (8...100)	°C
207	Maximum limitation of storage tank temperature	90 (8...100)	°C
208	Collector start function gradient	--- (---/1...20)	min/K

25.2 General

In the case of plant types with d.h.w storage tank, the RVD260 supports solar d.h.w. heating.

The function is activated...

- by parameterizing the input at terminal B72 (operating line 54),
- by selecting the d.h.w. sensor (operating line 98), **and**
- by appropriately parameterizing 1 of the 2 multifunctional relays (operating line 129 or 130).

Then, solar d.h.w. charging is always released. It is effected via the collector pump based on the temperature differential of d.h.w storage tank and collector.

Storage tank sensor B32 at the bottom is used for solar charging control. If that sensor is not installed, storage tank sensor B31 at the top is automatically used.

Symbol ☀ on the displays indicates solar d.h.w. charging.

When using 2 storage tank sensors, the temperature drop for the sensor at the bottom must be set depending on the type of storage tank (operating line 119).

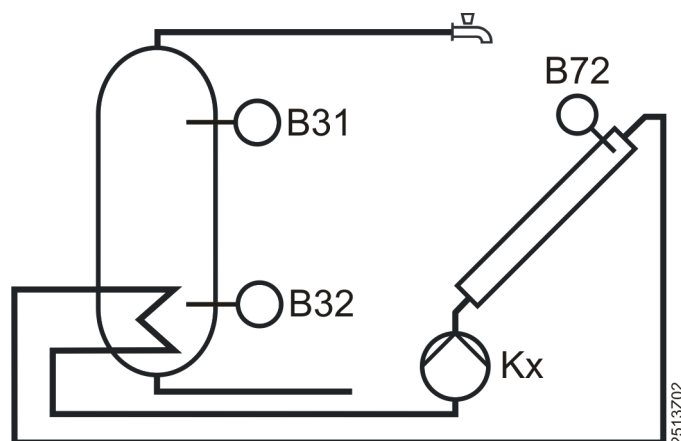

- B31 Storage tank sensor 1
- B32 Storage tank sensor 2
- B72 Collector sensor
- Kx Collector pump

25.3 Functions

25.3.1 Temperature differential ON/OFF solar

Operating lines 201 and 202 are used to set the temperature differential for switching solar d.h.w. charging on and off.

A sufficiently large temperature differential of collector and d.h.w. storage tank is required for charging; in addition, the collector must have reached the minimum charging temperature.

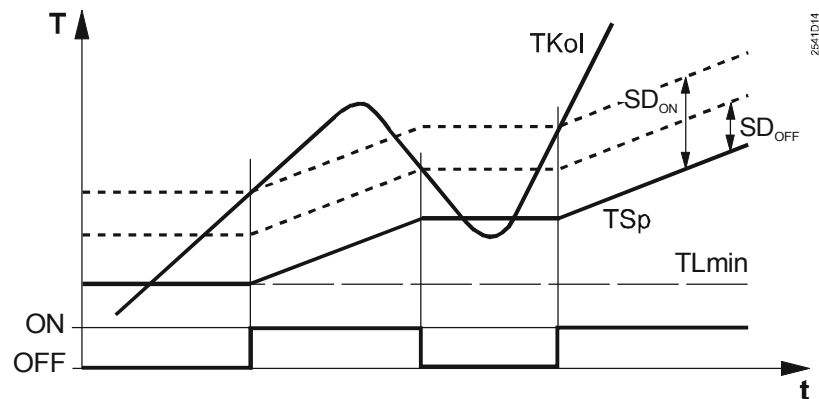

TKol	Collector temperature	TSp	Storage tank temperature
ON/OFF	Collector pump	TLmin	Minimum charging temperature
SD _{ON}	Temperature differential ON	T	Temperature
SD _{OFF}	Temperature differential OFF	t	Time

- The storage tank is charged when the collector temperature exceeds the current storage tank temperature by the switch-on differential: $TKol > TSp + SD_{ON}$
- Storage tank charging is stopped when the collector temperature drops below the switch-off differential: $TKol < TSp + SD_{OFF}$

25.3.2 Minimum charging temperature

The collector pump is activated only when the collector reaches a minimum temperature of 30°C and when the required temperature differential is attained.

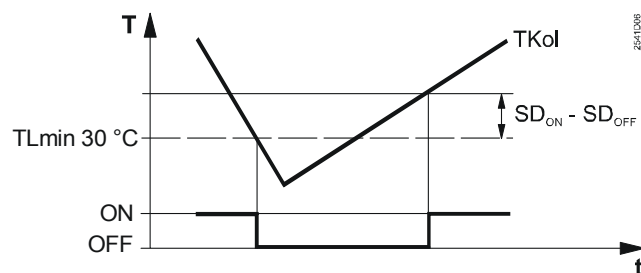

TKol	Collector temperature
ON/OFF	Collector pump
SD _{ON}	Temperature differential ON
SD _{OFF}	Temperature differential OFF
TLmin	Minimum charging temperature
T	Temperature
t	Time

- Charging is aborted (even if the switch-on differential is reached) when the collector temperature lies below the minimum charging temperature: $TKol < TLmin$
- Charging takes place when the collector temperature exceeds the minimum charging temperature by the switch-on differential ($SD_{ON} - SD_{OFF}$) (and when the required switch-on differential is reached): $TKol > TLmin + (SD_{ON} - SD_{OFF})$

25.3.3 Minimum running time

When the collector pump is activated, it keeps running for a minimum time of $t_{Min} = 20$ seconds. This minimum on time is active with all functions that switch on the collector pump.

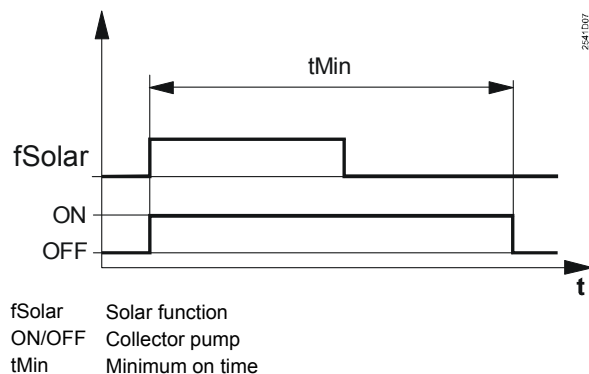

Special case frost protection

To ensure that the flow pipe from the collector to the storage tank is flushed with hot water, switching off of the collector pump after reaching the frost protection limit at the collector sensor is delayed by the minimum running time.

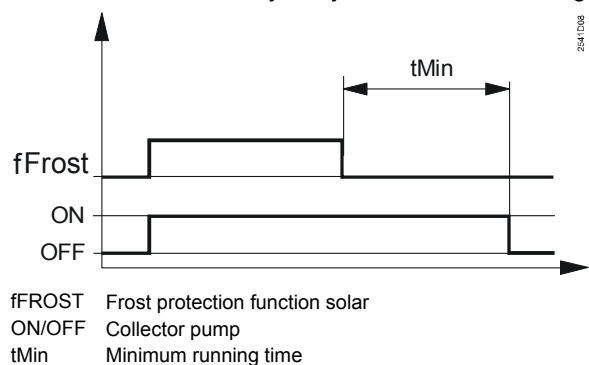

25.3.4 Frost protection temperature for collector

Operating line 203 is used to set the frost protection temperature for the collector. If there is risk of frost at the collector, the collector pump is activated to prevent the heat conducting medium from freezing.

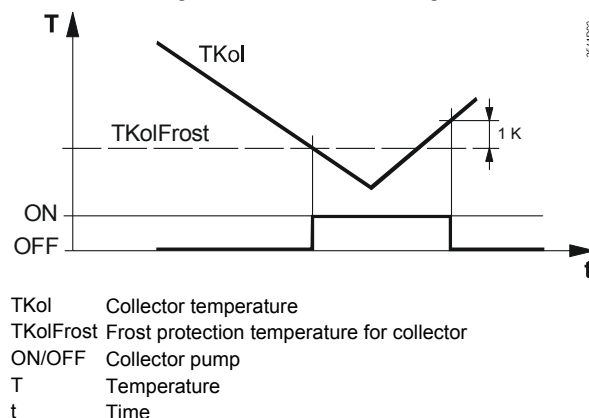

- The collector pump is activated when the collector temperature drops below the frost protection temperature: $TK_{ol} < TK_{olFrost}$
- The collector pump is deactivated when the collector temperature rises 1 K above the frost protection temperature: $TK_{ol} > TK_{olFrost} + 1\text{ K}$
- The frost protection function is aborted when the d.h.w. storage tank temperature drops below 8 °C
- Setting --- deactivates the frost protection function for the collector

25.3.5 Overtemperature protection for collector

Operating line 204 is used to set the temperature that protects the collector against overheating.

If there is a risk of collector overtemperature, storage tank charging is continued beyond maximum limitation of the charging temperature (set on operating line 206) until maximum limitation of the storage tank temperature is reached (set on operating line 207), aimed at lowering the amount of surplus heat.

When maximum limitation of the storage tank temperature is reached, overtemperature protection for the collector is no longer possible, and the collector pump is deactivated.

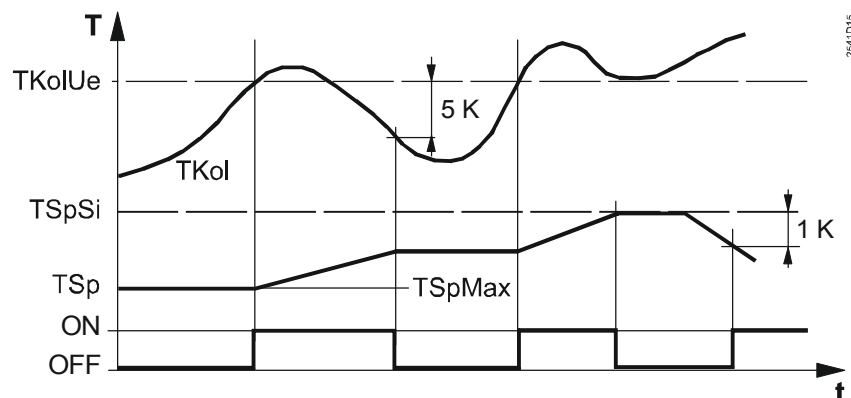

TSpSi	Maximum limitation of storage tank temperature
TSp	Storage tank temperature
TKoIUe	Overtemperature protection for collector
TSpMax	Maximum limitation of charging temperature
TKol	Collector temperature
ON/OFF	Collector pump
T	Temperature
t	Time

- If the collector temperature exceeds the overtemperature protection level and maximum limitation of the storage tank temperature is not yet reached, the collector pump is activated: $TKol > TKoIUe$ and $TSp < TSpSi$. If the collector temperature drops 5 K below the overtemperature protection level, the collector pump is deactivated: $TKol < TKoIUe - 5 K$
- If the current storage tank temperature rises to the maximum limit value, the collector pump is deactivated: $TSp > TSpSi$
If the storage tank temperature drops 1 K below maximum limitation of the d.h.w. storage tank temperature, the collector pump is activated again: $TSp < TSpSi - 1 K$
If 2 storage tank sensors are installed, the sensor acquiring the highest temperature is considered.

When using setting ---, overtemperature protection for the collector is switched off.

25.3.6 Storage tank recooling

After overtemperature protection for the collector has been active, function "Storage tank recooling" discharges the d.h.w. storage tank to bring it down to a lower temperature level.

Storage tank recooling is effected via the collector's surface. For that, the collector pump is activated, thus transferring heat from the d.h.w. storage tank to the collector to be emitted to the environment via the collector's surface.

The recooling setpoint (TRk) is set to a fixed 80 °C.

The switching differential for recooling (SD_{ON}) corresponds to the value of the switch-on differential (operating line 201) of charging control, but is limited to a minimum of 3 K for recooling.

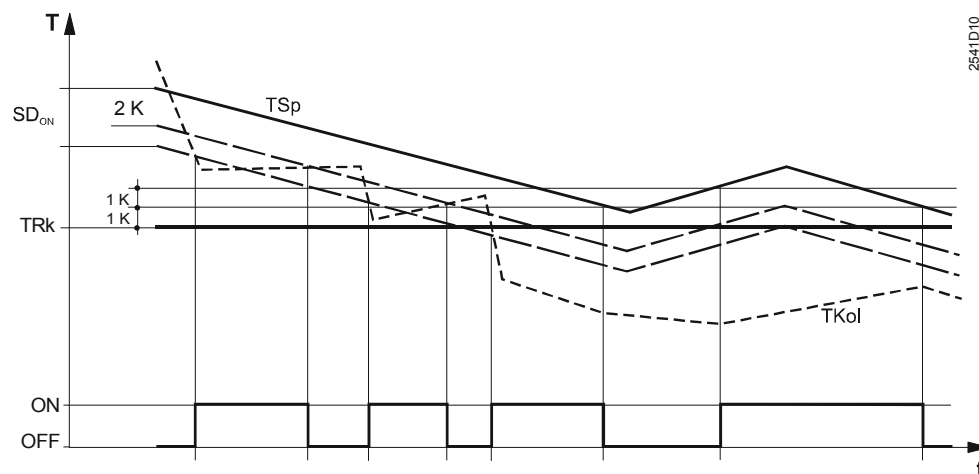

SD _{ON}	Temperature differential ON	ON/OFF	Collector pump
TRk	Recooling setpoint	T	Temperature
TSp	Storage tank temperature	t	Time
TKol	Collector temperature		

- If the storage tank temperature lies at least 2 K above the recooling setpoint and by at least temperature differential ON above the collector temperature, the collector pump is activated:
 $TSp > TRk + 2 \text{ K}$ and $TSp > TKol + SD_{ON}$
- If the collector temperature rises to a level of 2 K below the storage tank temperature, the collector pump is deactivated:
 $TKol > TSp - 2 \text{ K}$
- If the storage tank temperature reaches a level of 1 K above the recooling setpoint, the function is ended:
 $TSp < TRk + 1 \text{ K}$

25.3.7 Evaporation temperature of heat conducting medium

Operating line 205 is used to set the evaporation temperature of the heat conducting medium.

If there is a risk of evaporation of the heat conducting medium (due to the high collector temperature), the collector pump is deactivated to prevent it from running hot. This is a pump protection function.

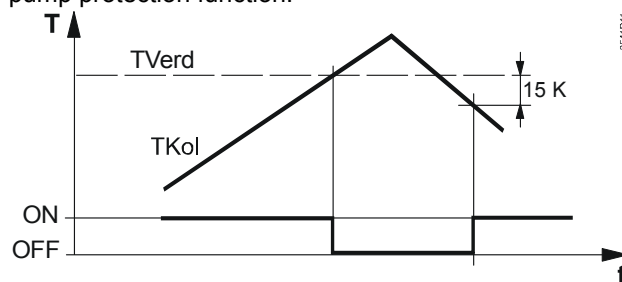

TVerd	Evaporation temperature of heat conducting medium
TKol	Collector temperature
ON/OFF	Collector pump
T	Temperature
t	Time

- If the collector temperature exceeds the evaporation temperature, the collector pump is deactivated:
 $TKol > TVerd$
- When the collector temperature drops 15 K below the evaporation temperature, the collector pump is activated again:
 $TKol < TVerd - 15 \text{ K}$

Setting --- deactivates the pump protection function.

Evaporation protection of the heat conducting medium (pump off) takes priority over overtemperature protection which would activate the pump.

25.3.8 Maximum limitation of charging temperature

Operating line 206 is used to set the maximum limitation for the charging temperature. When the maximum charging temperature in the storage tank is reached, the collector pump is deactivated.

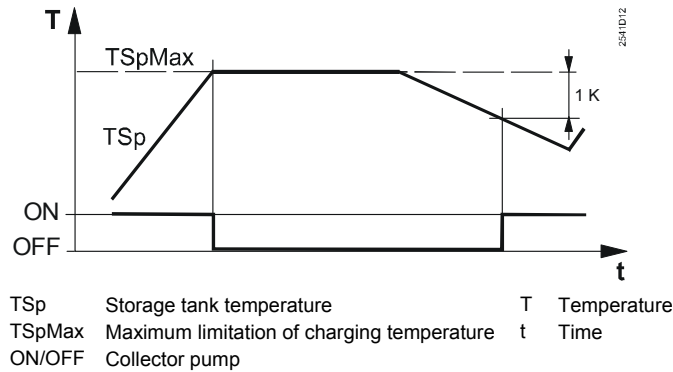

- If the storage tank temperature exceeds its maximum limit value, charging is aborted:
 $T_{Sp} > T_{SpMax}$
- When the storage tank temperature drops 1 K below its maximum limit value, charging is released again:
 $T_{Sp} < T_{SpMax} - 1 \text{ K}$

Note:

Overtemperature protection for the collector can again activate the collector pump until the storage tank temperature reaches its maximum limit value.

25.3.9 Maximum limitation of storage tank temperature

Operating line 207 is used to set the maximum limitation of the d.h.w. storage tank temperature.

The storage tank is never charged above the set temperature (refer to 25.3.5 "Overtemperature protection for collector").

Caution

Maximum limitation of the storage tank temperature is not a safety function!

25.3.10 Collector start function

The controller is supplied with the collector start function deactivated.

Since the collector's temperature (primarily vacuum pipes) cannot be reliably acquired when the pump is off, the pump can be activated based on an adjustable gradient [min/K].

Operating line 208 is used to set the gradient for the collector start function. The gradient represents the collector's off temperature increase per minute.

- Gradient = 1 [min/K]: Representing a temperature increase of 1 [K/min]
- Gradient = 20 [min/K]: Representing a temperature increase of 1/20 [K/min]

If, within 1 minute, the temperature acquired by the collector sensor rises by more than the set gradient, the pump is activated (minimum running time 20 seconds). If the required collector charging temperature is reached within the period of time the pump runs, solar d.h.w. charging is started and the pump remains activated. If the collector temperature does not reach the required level, or drops again, the pump is again deactivated. The pump remains activated for maximum 1 minute plus the minimum running time (20 seconds), if the solar charging function does not provide control of the pump.

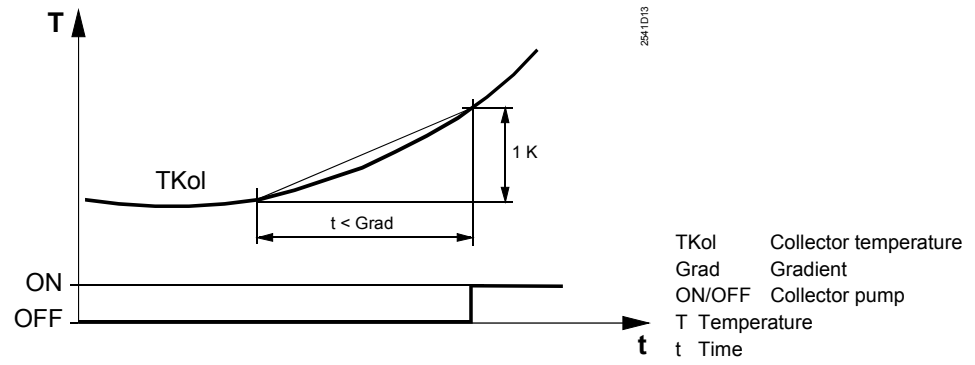

Setting --- deactivates the collector start function.

26 Function block: Refill functions

26.1 Operating lines

Function block "Refill functions" provides settings for the heating engineer.

Line	Function, parameter	Factory setting (range)	Unit
211	Relative secondary minimum pressure	--- (---/0.5...10)	bar
212	Refill locking time after shutdown	10 (---/10...2400)	min
213	Minimum secondary underpressure period	10 (---/10...2400)	s
214	Secondary switching differential	0.3 (0.1...1.0)	bar
216	Maximum refill period per charging cycle	--- (---/10...2400)	s
217	Maximum refill period per week	--- (---/1...1440)	min
218	Secondary pressure sensor U1: Pressure at 10 V	10 (0...100)	bar
219	Secondary pressure sensor U1: Pressure at 0 V	0 (-10...0)	bar
220	Primary pressure sensor U2: Pressure at 10 V	10 (0...100)	bar
221	Primary pressure sensor U2: Pressure at 0 V	0 (-10...0)	bar
222	Resetting the counters "Refill period charging cycle" "Refill period week"	0 (0/1)	

26.2 General

The RVD260 supports the refill function, aimed at maintaining the plant pressure on the secondary side.

If this pressure drops below a minimum level, water from the primary side or from an external tank is added to the secondary plant circuit, thus increasing the pressure again.

Local regulations and the regulations released by the district heat utility must be observed.

The pressure for the refill function should be acquired at the same location as the pressure of the expansion vessel.

Refilling from primary circuit

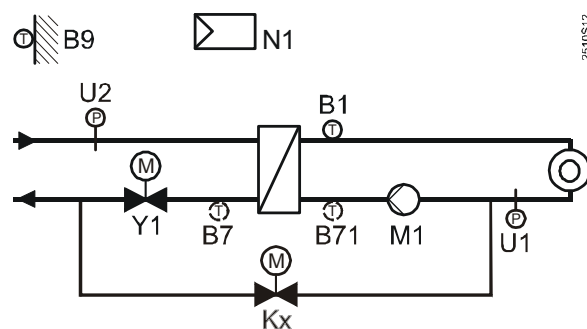

Refilling from external storage tank

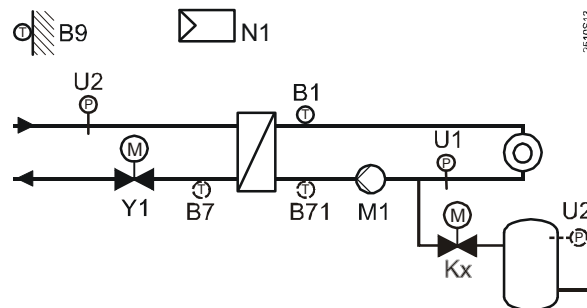

- Kx Refill valve
- U1 Secondary pressure sensor
- U2 Primary pressure sensor

26.3 Mode of operation

26.3.1 Overview of functions

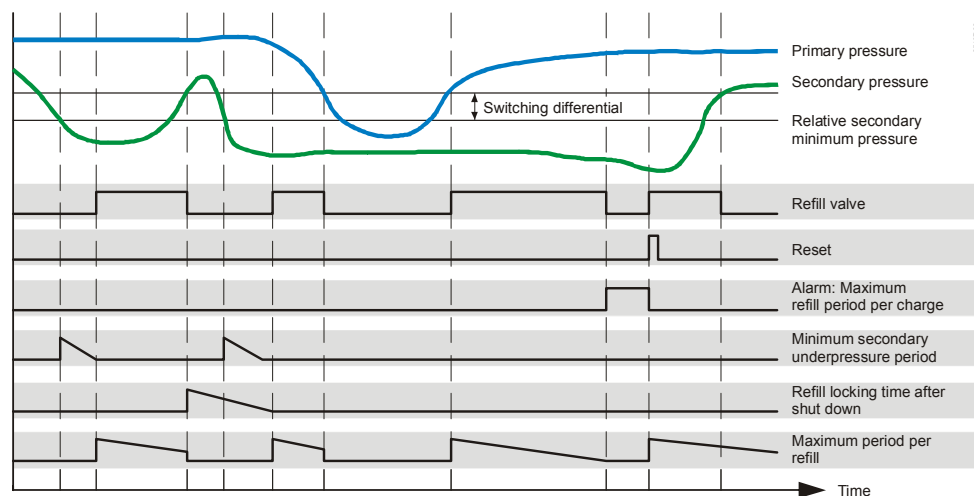

26.3.2 Relative secondary minimum pressure

To activate the refill function, input B71/U1 is to be parameterized via operating line 52 (refer to chapter 11 "Function block: Plant configuration"), 1 of the 2 multifunctional relays K6 or K7 for the refill function is to be configured via operating line 129 or 130 (refer to chapter 19 "Function block: Multifunctional relays") and the relative secondary minimum pressure is to be set on operating line 211.

26.3.3 Refill locking time after shutdown

If there is a leak on the secondary side which – temporarily – can be compensated for by the refill function, that function is constantly activated and deactivated. To prevent this, a refill locking time can be set on operating line 212. In that case, the refill valve is locked for the parameterized time when refilling is completed. The function can be deactivated.

26.3.4 Minimum secondary underpressure period

When a pump is activated, pressure variations of short duration can occur. On operating line 213, a minimum duration of secondary underpressure can be parameterized, preventing such pressure variations from triggering the refill function. Refilling takes place only if the secondary pressure lies below the secondary minimum pressure for at least the parameterized minimum secondary underpressure period. The function can be deactivated.

26.3.5 Secondary switching differential

The secondary switching differential for the refill function is to be set on operating line 214.

26.3.6 Function of primary pressure sensor (U2)

The function of terminal B7/U2 is to be selected via operating line 53 (refer to chapter 11 "Function block: Plant configuration"). For the refill function, the secondary pressure sensor (U1) is required. The primary pressure sensor (U2) can be used for...

- display, **or**
- monitoring.

When monitoring the primary pressure, recharging is locked if the pressure on the primary side drops below the relative secondary minimum pressure plus the switching differential. Recharging would not make sense in that case since it could never be finished.

26.3.7 Maximum refill period per charging cycle

Operating line 216 is used to set the maximum refill period per charging cycle. If, after opening the refill valve, the secondary pressure does not exceed the setpoint during the set maximum refill period per charging cycle, the valve is locked and a fault is displayed.

Further recharging is effected only after resetting the counter "Refill period per charging cycle". The function can be deactivated.

26.3.8 Maximum refill period per week

Operating line 217 is used to set the maximum refill period per week. If the time required for the refill cycles per week reaches the maximum refill period, the valve is locked and a fault is displayed.

Further recharging is effected only after resetting the counter "Refill period per week". The function can be deactivated.

26.3.9 Configuration of sensors

Since the sensors used cover different pressure and voltage ranges, the resulting pressure values for 0 V and 10 V can be set on operating lines 218 through 221. The resolution of the 2 DC 0...10 V inputs U1 and U2 is 10 mV (0.1%). Hence, for a pressure sensor having a measuring range of 1 bar, the resolution is 1 mbar.

26.3.10 Resetting the counters refill period per charging cycle, per week

If buttons \leftarrow and \rightarrow are pressed until the display changes from 0 to 1, the 2 counters "Refill time per charging cycle" and "Refill time per week" are reset and the faults (refer to chapter 10 "Function: Display of faults") are canceled.

27 Function block: DRT and maximum limitation of return temperature

27.1 Operating lines

Function block "DRT and maximum limitation of return temperature" provides settings for the heating engineer.

Line	Function, parameter	Factory setting (range)	Unit
226	Maximum limitation of primary return temperature	0 (0/1)	
227	Upper constant value, maximum limitation of primary return temperature	70 (variable...140)	°C
228	Slope, maximum limitation of primary return temperature	7 (0...40)	
229	Start of compensation (point of inflection), maximum limitation of the primary return temperature	10 (-50...50)	°C
230	Lower constant value, maximum limitation of primary return temperature	50 (0...variable)	°C
231	Maximum setpoint of return temperature during d.h.w. charging	--- (---/0...140)	°C
232	Maximum limitation of secondary return temperature, difference to the primary limit value	--- (---/0...50)	K
233	Integral action time of primary return temperature limitations	30 (0...60)	min
234	Limit value of maximum limitation of temperature difference (DRT)	-- (-/-/0.5...50.0)	K
235	Maximum setpoint of return temperature during d.h.w. heating to the legionella setpoint	--- (---/0...140)	°C

Note:

This function block contains all parameters required for the district heating network. Since many district heat utilities require the settings to be locked, they are arranged on the locking functions level.

The following function blocks are also assigned to the locking functions level. It includes all operating lines from 226 through 251. This level can only be accessed with a code. Refer to chapter 31.1.6 "Setting levels and access rights".

Locking on the hardware side is possible also (operating line 251).

27.2 Maximum limitation of primary return temperature

27.2.1 General

The primary return temperature uses maximum limitation to...

- prevent too hot water from being fed back to the district heating network,
- minimize the pumping power of the district heat utility,
- comply with the regulations of the utility (connection requirements).

Maximum limitation of the return temperature acquires the return temperature on the primary side and throttles the primary 2-port valve if the limit value is exceeded.

Maximum limitation acts separately on both heating circuits and on the d.h.w. circuit. The limit values and basic settings made on operating lines 227 through 233 apply to both heating circuits, but the control operates independently.

With the types of plant that use a common flow (2-x and 3-x), the valid limit value is controlled by the demand for heat of the heating circuits and of the d.h.w. circuit. When both the heating circuits and the d.h.w. circuit call for heat, the higher of the limit values applies.

Maximum limitation of the primary return temperature has priority over minimum limitation of the flow temperature in the heating circuit.

27.2.2 Maximum limitation in heating mode

The limit value for maximum limitation in heating mode is generated from the following variables:

- Function can be activated or deactivated for each heating circuit (selection on operating line 226)
- Upper constant value (setting on operating line 227)
- Lower constant value (setting on operating line 230)
- Slope (setting on operating line 228)
- Start of compensation (setting on operating line 229)

The current limit value can be determined as follows:

- If the outside temperature is higher than or equal to the value set for the start of compensation (setting on operating line 229), the current limit value is the constant value entered on operating line 230
- If the outside temperature lies below the value set for the start of compensation, the current limit value T_L is calculated according to the following formula:

$$T_L = T_{L \text{ constant min}} + [(T_{L \text{ start}} - T_A) \times s \times 0.1]$$

However, the current limit value T_L cannot lie above the upper limit value.

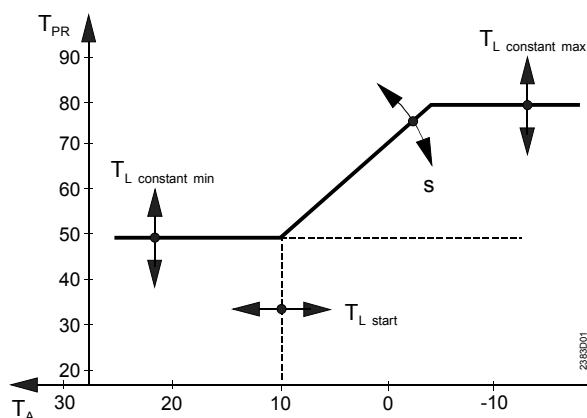

s	Slope (operating line 228)
T_A	Current outside temperature
$T_{L \text{ constant max}}$	Upper constant value (operating line 227)
$T_{L \text{ constant min}}$	Lower constant value (operating line 230)
$T_{L \text{ start}}$	Start of compensation (operating line 229)
T_{PR}	Primary return temperature

Limitation operates according to the selected characteristic:

- When the outside temperature falls, the return temperature is initially limited to the lower constant value
- If the outside temperature continues to fall, it reaches the selected starting point for shifting compensation. From this point, the limit value is raised as the outside temperature falls. The slope of this section of the characteristic can be adjusted. The setting range is 0...10; the effective value is 10 times smaller
- If the outside temperature falls further, the return temperature is limited to the upper constant value

27.2.3 Maximum limitation in d.h.w. heating mode

In contrast to maximum limitation in heating mode, maximum limitation of the primary return temperature in d.h.w. mode uses a constant value. It is to be set on operating line 231.

To reach the required anti-legionella temperature in the storage tank, a maximum set-point for the return temperature acts during the time the legionella function is activated.

If set to inactive (operating line 235 = ---), there is no maximum limitation of the return temperature during the time the legionella function is activated.

If both the heating circuit and the d.h.w. circuit call for heat **and** maximum limitation of the return temperature acts on both circuits, the higher limit value applies.

If, with plant type 1–3, maximum limitation of the return temperature is deactivated (entry ---), the d.h.w. temperature is controlled according to the return temperature acquired by sensor B71 because there is no sensor in the d.h.w. flow. The control setpoint is the sum of the current d.h.w. setpoint plus charging boost (operating line 116).

The current d.h.w. setpoint is generated internally and can be displayed as follows:

Select operating line 26 and press \triangleleft .

27.3 Maximum limitation of secondary return temperature

The secondary return temperature of both the heating circuit and the d.h.w. circuit can be limited to a maximum, depending on the type of plant. The limit value is to be entered on operating line 232 as a reduction to the current limit value of the maximum limitation of the primary return temperature.

This function can become active only when the respective maximum limitation of the primary return temperature (heating circuits or d.h.w.) is switched on. It can be deactivated on operating line 226 for the heating circuit return (separately for each heating circuit) and on operating line 231 for the d.h.w. return.

Example:

With plant type 2–2, the parameters are selected as follows:

Operat. line 226 = 1 Max. limitation of return temperature heating circuit 2 ON
 Operat. line 227 = 70 °C Upper constant value
 Operat. line 228 = 7 Slope
 Operat. line 229 = 10 °C Start of compensation at an outside temperature of 10 °C
 Operat. line 230 = 50 °C Lower constant value
 Operat. line 231 = 55 °C Maximum limitation of return temperature, d.h.w. circuit
 Operat. line 232 = 5 °C Reduction on secondary side

Different outside temperatures lead to different maximum limitations:

<i>Outside temperature</i>	<i>Heating circuit 1</i>		<i>D.h.w. circuit</i>	
	<i>Primary side</i>	<i>Secondary side</i>	<i>Primary side</i>	<i>Secondary side</i>
15 °C	50 °C (operating line 230)	45 °C (operating lines 230...232)	55 °C (operating line 231)	50 °C (operating lines 231...232)
-5 °C*	60.5 °C**	55.5 °C		
-20 °C	70 °C (operating line 227)	65 °C (operating lines 227...232)		

* With shifting compensation

** According to equation in chapter 27.2.2 "Maximum limitation in heating mode"

27.4 Maximum limitation of return temperature differential (DRT function)

27.4.1 Mode of operation

With the types of plant that have sensor B71 fitted in the secondary return of the heating circuit or in the secondary return of the heat exchanger, maximum limitation of the temperature differential (DRT, difference of primary and secondary return temperature) can be provided. With plant type 1–0, it is also possible to monitor the return temperature differential of heating circuit 2 using sensor B3.

If the differential of the 2 return temperatures exceeds the adjusted maximum limit value, 2-port valve Y1 in the primary circuit is throttled.

27.4.2 Purpose

Limitation of the return temperature differential generally ensures that a smaller amount of heat is drawn from the district heating network or that the volumetric flow is throttled when heat is demanded for the first time in the morning when the pipes are still cold (prevention of idle heat and no unnecessary supply of heat back to the network by keeping the return temperature as low as possible). In addition, the DRT function...

- acts as a dynamic limitation of the return temperature,
- shaves peak loads.

Impact of maximum limitation of return temperature differential:

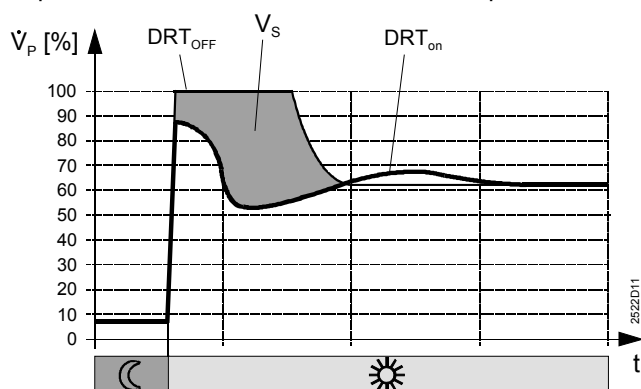

DRT_{ON} With active maximum limitation of return temperature differential

DRT_{OFF} Without maximum limitation of return temperature differential

t Time

\dot{V}_p Volumetric flow on primary side

V_s Volume saved

The return temperature differential is usually 2...5 °C and depends on the type of heat exchanger. Maximum limitation of the return temperature differential can be deactivated on operating line 234 (entry of --.). Maximum limitation of the return temperature differential is given priority over minimum limitation of the flow temperature in the heating circuit. During d.h.w. charging cycles, maximum limitation of the return temperature differential is deactivated with all types of plant.

27.5 Integral action time of limit functions

With the maximum limitations of the return temperature and the return temperature differential, an integral action time determines the rate at which the flow temperature setpoint is reduced.

- Short integral action times lead to faster reductions
- Long integral action times lead to slower reductions

With this setting (on operating line 233), the effect of the limit function can be matched to the type of plant.

28 Function block: Miscellaneous

28.1 Operating lines

Function block "Miscellaneous" provides settings for the heating engineer.

Line	Function, parameter	Factory setting (range)	Unit
236	Limit function at contact H5	1 (1/2)	
237	Limit value of volumetric flow or power limitation	75 (5...1500)	Imp/min
238	Integral action time of limit function at contact H5	60 (0...240)	min
240	Locking time after minimum limitation for the suppression of hydraulic creep	6 (---/1...20)	min
241	Start of compensation (point of inflection), increase of reduced room temp. setpoint	5 (-50...50)	°C
242	Slope, increase of reduced room temperature setpoint	0 (0...10)	
243	Forced charging at the beginning of release period 1	1 (0/1)	
244	Cooling down protection primary flow	--- (---/3...255)	min

Note:

Function **Forced charging at the beginning of release period 1** on operating line 243 is only possible with d.h.w. heating with a storage tank and is described there (refer to chapter 15.10 "D.h.w. heating with storage tanks").

Function **Cooling down protection primary flow** on operating line 244 is only available with direct d.h.w. heating via heat exchanger and is described there (refer to chapter 15.12 "Direct d.h.w. heating").

28.2 Limit function at input H5

Input H5 at the RVD260 can be configured for the reception of energy and/or volumetric flow pulses from heat meters. (Entry on operating line 56 must be 1; in addition, the way the limit function shall act on the heating circuits must be configured on operating line 57). These pulses activate a limit function in the controller. The kind of limitation can be selected via operating line 236:

Setting	Type of pulse	Function
1	Energy or volumetric flow pulses	Maximum limitation with adjustable limit value
2	Energy and/or volumetric flow pulses	Maximum limitation at a fixed value of 75 pulses/min (corresponding to 100% load)

The limit value is to be set on operating line 237. When the current number of pulses reaches the set limit value or 100% load, actuating device Y1 (2-port valve in the primary return) is throttled. The action is always restricted to the primary side of the plant. To enhance the control performance, the integral action time of the limit function can be adjusted on operating line 238. It applies to both maximum limitation with an adjustable limit value and to limitation with a fixed value. The setting value determines the rate at which the flow temperature setpoint is reduced:

- Short integral action times lead to faster reductions
- Long integral action times lead to slower reductions

With this setting, the effect of the limit function can be matched to the type of plant.

If, with setting 2, no more pulses are received for 20 seconds, error code 180 is generated on operating line 50 (connection to heat meter interrupted) because the minimum pulse rate expected there is always 5 pulses/min.

28.3 Suppression of hydraulic creep

28.3.1 Mode of operation

To avoid measuring errors in connection with heat metering due to extremely small flow rates, the flow through the 2-port valve in the primary return can be limited to a minimum (Y_{\min} function). This ensures that consumers will not be able to draw heat that cannot be measured and billed.

When the valve's position reaches the minimum limit value, the valve is driven to the fully position. When the flow temperature drops below its setpoint and a change of flow temperature setpoint is detected, or the locking time has already elapsed, the valve opens again and the controller resumes normal operation.

The locking time must be set. This is made on operating line 240, separately for each heating circuit, where the function can also be deactivated by entering ---.

The suppression of hydraulic creep always acts on regulating unit Y1 in the primary return.

If suppression of hydraulic creep is active, the display shows J . It is given priority over all other limitations and, in the case of plant types with a common flow (2-x and 3-x) also acts during d.h.w. heating.

There is no suppression of hydraulic creep in the d.h.w. circuit connected to the primary side.

28.3.2 Mode of operation

The valve stroke corresponding to the minimum limit value is acquired by an auxiliary switch fitted in the actuator and then delivered to the controller. The auxiliary switch is connected to terminals B7-M. When the valve reaches the minimum limit value, the auxiliary switch closes. When B7-M closes, the valve is driven to the fully closed position.

When the flow temperature drops below its setpoint and a change of flow temperature setpoint is detected, or the locking time has already elapsed, the valve opens again. The valve opens until B7-M is no longer closed, or the flow temperature exceeds the setpoint by more than 10 K. If 1 of these 2 cases occurs, the controller resumes normal operation.

28.4 Increase of reduced room temperature setpoint

The reduced room temperature setpoint can be raised as a function of falling outside temperature. This prevents...

- too great changes from the reduced to the nominal setpoint when outside temperatures are low,
- extreme heating loads during the heating up phase.

The starting point to be set is the outside temperature in °C (start of compensation, operating line 241). The reduced room temperature setpoint is only raised at outside temperatures below the starting point; an increase is not required when outside temperatures are higher. The degree of increase is to be set in the form of a slope (operating line 242); the slope represents the setpoint increase per °C outside temperature drop. The setting range is 0...10; the effective value is 10 times smaller.

The temperature used is the **composite** outside temperature.

The function can be deactivated (by entering 0 for the slope).

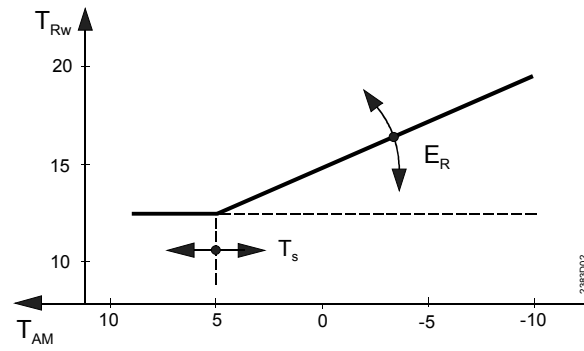

- E_R Impact or slope (operating line 242)
- T_{AM} Composite outside temperature
- T_{Rw} Reduced room temperature setpoint
- T_s Start of compensation (operating line 241)

29 Function block: Operation locking functions

29.1 Operating lines

Function block "Operation locking functions" provides settings for the heating engineer.

<i>Line</i>	<i>Function, parameter</i>	<i>Factory setting (range)</i>	<i>Unit</i>
250	Locking on the software side	0 (0...4)	
251	Locking of "Locking functions" level on the hardware side (operating lines 226...250)	(0/1)	

29.2 Locking settings on the software side

The settings on all levels, or a certain part of them, can be locked on the software side. They can still be read after locking, but can no longer be changed. The choices available on operating line 250 are the following:

<i>Setting</i>	<i>Locking on the software side</i>
0	No locking
1	D.h.w. settings locked. This applies to the following operating lines: 18...23 = d.h.w. program 41...42 = d.h.w. setpoints 101 = release of d.h.w. heating 125 = assignment d.h.w. charging
2	Heating engineer level locked
3	D.h.w. settings and heating engineer level locked
4	All settings locked

29.3 Locking of locking functions level on the hardware side

In addition to locking all settings on the software side, this function is used to lock the "Locking functions" level on the hardware side. The respective setting is to be made on operating line 251:

<i>Setting</i>	<i>Locking on the hardware side</i>
0	No locking of "Locking functions" level
1	Settings made on "Locking functions" level are locked

If locking on the hardware side is activated, the "Locking functions" level can be accessed only if terminals B31–M were previously linked.

For detailed information about access to the "Locking functions" level, refer to chapter 31.1.6 "Setting levels and access rights".

30 Combination with PPS devices

30.1 General

- PPS devices are digital peripheral devices for connection to the PPS (point-to-point interface, terminals A6–MD) of the controller. Such devices are presently the following:
 - Room units QAW50, QAW50.03 and QAW70
 - Room sensor QAA10
- The room temperature acquired by a room unit is adopted by the controller. If the room temperature shall not be considered by the control functions, room influence on operating line 70 must be set to 0. In that case, the other room unit functions are used
- If an inadmissible unit is connected, the RVD260 identifies a fault
- A room unit is switched to the passive state; this means that all entries made on it will have no impact
- The operating mode of d.h.w. heating is independent of a room unit's operating mode. Exception is the holiday function (refer to chapter 30.3.6 "Entry of holidays")
- The room unit also acts fully on the controller when an operation locking function on the controller is activated (operating lines 250 and/or 251: Setting >0)
- A short-circuit at the PPS leads to an error message; an interruption represents a permitted state (no device present)

30.2 Combination with room unit QAW50...

30.2.1 General



Room unit QAW50..., with room sensor, operating mode selector, knob for room temperature setpoint readjustments and economy button

The QAW50... can act on the RVD260 as follows:

- Overriding the operating mode
- Readjustment of room temperature

For that purpose, the QAW50... has 3 operating elements:





- Operating mode selector
- Economy button (also called presence button)
- Knob for readjustment of the nominal room temperature setpoint

30.2.2 Overriding the operating mode

From the QAW50..., the operating mode of the RVD260 can be overridden. This is made with the operating mode selector and the economy button.

For the room unit to act on the RVD260, the controller work in automatic operation.

The impact of the room unit's operating mode selector on the RVD260 is as follows:

Op. mode QAW50...	Operating mode RVD260
	Automatic operation; temporary overriding with the economy button of the QAW50... possible
	Economy button off (lit): Nominal room temperature
	Economy button on (dark): Reduced room temperature
	Protection mode (standby)

If the room unit overrides the controller's operating mode, operating mode button  on the controller flashes.

30.2.3 Knob for room temperature readjustments

Using the knob of the QAW50..., the nominal room temperature setpoint can be readjusted by a maximum of ± 3 K.

Adjustment of the room temperature setpoint on the controller is not affected by the QAW50.... The controller generates the setpoint from its own room temperature adjustment plus the readjustment made with the room unit.

30.2.4 Controller with operation lock

The room unit also acts fully on the controller when an operation locking function on the controller has been activated (operating lines 250 and/or 251: Setting >0).

30.3 Combination with room unit QAW70

30.3.1 General



Room unit QAW70 with room sensor, time switch, setpoint adjustment, knob for room temperature setpoint readjustments and economy button

Using the QAW70, the following functions can be performed or actions achieved on the RVD260:





- Overriding the operating mode
- Overriding the room temperature setpoints
- Overriding the d.h.w. setpoint
- Readjustment of room temperature
- Entry of time of day
- Change of the controller's heating program
- Display of actual values and room temperature acquired by the controller

For that purpose, the QAW70 has the following operating elements:

- Operating mode button
- Economy button (also called presence button)
- Knob for readjustment of the nominal room temperature setpoint
- Buttons for selecting the operating lines
- Buttons for readjusting values

30.3.2 Overriding the operating mode

The controller's operating mode can be overridden from the QAW70. This is made with the operating mode button and the economy button. For the room unit to act on the RVD260, the controller must work in automatic operation. The impact of the room unit's operating mode buttons on the controller is as follows:

<i>Op. mode QAW70</i>	<i>Operating mode RVD260</i>
	Automatic operation; temporary overriding with the economy button of the QAW70 possible
	Economy button off (lit): Nominal room temperature
	Economy button on (dark): Reduced room temperature
	Protection mode (standby)

If the room unit overrides the controller's operating mode, operating mode button  on the controller flashes.

30.3.3 Knob for room temperature readjustments

Using the knob of the QAW70, the nominal room temperature setpoint can be readjusted by a maximum of ± 3 K.

Adjustment of the room temperature setpoint on the RVD260 is not affected by the QAW70.

30.3.4 Impact of the QAW70 operating lines on the RVD260

<i>Line on QAW70</i>	<i>Function, parameter</i>	<i>Impact on RVD260, notes</i>
1	Nominal room temperature setpoint	Overrides the setting on the controller
2	Reduced room temperature setpoint	Overrides the setting on the controller
3	D.h.w. temperature setpoint	Overrides the adjustment of the nominal setpoint on the controller. The setting range (controller operating line 117) remains valid
4	Weekday	For entering the heating program
5	Start of heating period 1	Changes the time switch settings on the controller
6	End of heating period 1	
7	Start of heating period 2	
8	End of heating period 2	
9	Start of heating period 3	
10	End of heating period 3	
11	Entry of weekday	Changes the time of day on the controller
12	Entry of time of day	

Table continued on next page

13	D.h.w. temperature	Display with plant type x-0: ---
14	---	No function
15	Flow temperature	Display of heating circuit flow temperature
16	Holidays (number of switch-off weekdays)	Heating circuit switches to protection mode  D.h.w. heating off
17	Reset to default values	QAW70 default entries apply

- If setpoints, time of day or the heating program are changed on the **room unit**, the changed settings are adopted by the **controller**
- If setpoints, time of day or the heating program are changed on the **controller**, the changed settings are adopted by the **room unit**
- For more detailed information, refer to the Installation Instructions of the QAW70 (G1637)

30.3.5 Controller with operation lock

The room unit also acts fully on the controller when an operation locking function on the controller has been activated (operating lines 250 and/or 251: Setting >0).



30.3.6 Entry of holidays

Using the QAW70 room unit, the controller can be switched to holiday mode. To be entered is the length of the holiday period in days. The LCD of the room unit displays the entry made as follows:

- The weekday on which the holiday period ends appears on the left (1 = Monday, 2 = Tuesday, etc.)
 - The number of days of the holiday period appears on the right
- Holiday mode starts the moment the entry is made.

In holiday mode, the controller operates as follows:

- The heating circuit is switched to standby (protection mode; when there is risk of frost, heating to the frost protection temperature is ensured)
- D.h.w. heating via district heating or electric immersion heater is off (when there is risk of frost, heating to the frost protection temperature is ensured)
- The holiday function is given priority over the room unit's operating mode

During the holiday period, the operating mode buttons of space heating  and d.h.w. heating  flash at a frequency of 2 Hz, provided the function was previously activated.

The holiday function can be deactivated prematurely by pressing the room unit's operating mode button.

The holiday function of the room unit operates independently of the controller's holiday function, meaning that holiday dates are not matched.

30.3.7 Freely programmable input

For a number of remote control and extra functions, the QAW70 room unit has a freely programmable input. This input offers the following connection choices:

- Analog room sensor QAW44 (NTC sensing element)
- Telephone contact
- Contact for common fault or window contact

The input is to be configured via operating lines 55 and 56 of the QAW70 room unit.

Impact of external devices

If an external room sensor QAW44 is connected to the QAW70, the latter generates the average of the 2 QAW temperature measurements according to the set authority (QAW70 operating line 57) and transmits it to the controller for the room temperature-dependent functions.

If the external telephone contact is used, the controller's behavior is the same as if holidays were entered.

30.4 Room sensor QAA10

Room sensor QAA10 can be used in place of a room unit. The QAA10 acquires the room temperature with an NTC sensing element; its sensing range is 0...32 °C.

31 Handling

31.1 Operation

31.1.1 General

Display and operating elements

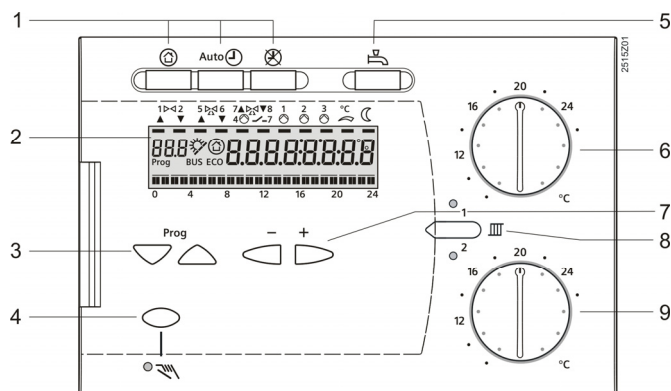

Front of RVD260

- 1 Operating mode buttons
- 2 Display (LCD)
- 3 Buttons for selecting the operating lines
- 4 Button for manual control ON/OFF
- 5 Button for d.h.w. heating ON/OFF
- 6 Knob for nominal room temperature setpoint of heating circuit 1
- 7 Buttons for adjusting values
- 8 Button for switching between the heating circuits
- 9 Knob for nominal room temperature setpoint of heating circuit 2

Display

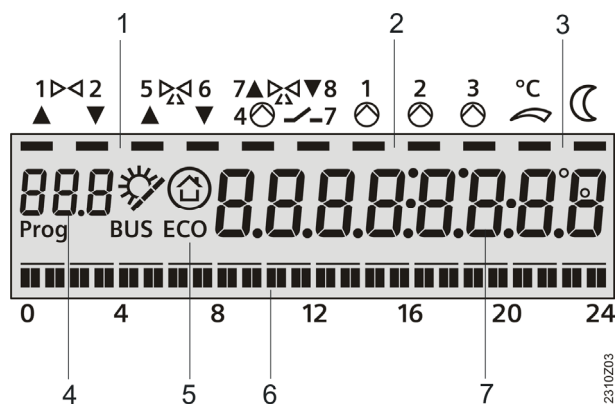

Display (LCD)

- 1 Display of positioning signals to the regulating units Y...
Example: Bar below number 1 lit = actuator Y7 receives OPEN pulses
- 2 Display of function of pumps Q...
Example: Bar below number 2 lit = pump M2 runs
- 3 Display of current temperature level (nominal temperature or reduced temperature)
Example: Bar below ☾ lit = heating to reduced temperature
- 4 Display of current operating line number
- 5 Display of "ECO function active" or "Protection mode active"
- 6 Display of current heating program
- 7 Display of temperatures, times, dates, etc.

Operating Instructions

Operating Instructions are inserted at the rear of the controller's front cover. They are provided for janitors and end-users and contain energy saving tips plus instructions on troubleshooting.

31.1.2 Analog operating elements

Selection of operating mode

Selection of operating mode:

- 3 buttons for selecting the heating circuit's operating mode
- 1 button for d.h.w. heating

The required operating mode is activated by pressing the respective button. Each button has an integrated LED; the currently active operating mode is indicated by the respective LED when lit.

Button for switching between the heating circuits

To make the heating circuit-specific settings or readings, this button must be pressed to select the required heating circuit. The active heating circuit is indicated by an LED. If both heating circuits are active, both LEDs are lit.

Knobs for room temperature adjustments

There are 2 knobs for the manual adjustment of the nominal room temperature setpoint of each heating circuit in °C. When turning the knobs, the respective heating curve is displaced parallel.

Buttons and display for manual control

A button is available to activate manual control. An LED indicates manual control; at the same time, the LEDs in the operating mode buttons extinguish. Manual control is quit by pressing the same button again or by pressing any of the operating mode buttons

31.1.3 Digital operating elements

Operating line principle

Entry and readjustment of all setting parameters, activation of functions and reading of actual values and states are based on the operating line principle. An operating line with an associated number is assigned to each parameter, each actual value and each function.

A pair of buttons is used to select operating lines and to readjust the display.

Buttons

To select and readjust setting values, the procedure is as follows:

<i>Buttons</i>	<i>Action</i>	<i>Effect</i>
Line selection buttons	Press ▾	Selection of the next lower operating line
	Press ▴	Selection of the next higher operating line
Setting buttons	Press ◀	Decrease of the displayed value
	Press ▶	Increase of the displayed value

The set value is adopted...

- when selecting the next operating line by pressing ▴ or ▾, and
- by pressing one of the operating mode buttons.

If entry of --.- or --:-- is required, ◀ or ▶ is to be pressed until the required value appears on the display. Then, the display keeps showing --.- or --:--.





Block jump function

The operating lines are grouped in the form of blocks. To quickly select an individual operating line in a block, the other lines can be skipped. This is accomplished by using 2 combinations of buttons:

<i>Action</i>	<i>Effect</i>
Keep ▾ depressed and press ▶	Selection of the next higher block
Keep ▾ depressed and press ◀	Selection of the next lower block

31.1.4 Controller in "unoperated state"

The controller works in "unoperated state" when no button has been pressed for the last 8 minutes, or when one of the operating mode buttons was previously pressed.

When in "unoperated state", the time of day and all actual values can be queried by pressing  and . The code numbers of the actual values are identical with those on operating line 161. Any active limitations are displayed with  or  according to their priorities. They can be queried on operating line 169.

When switching on again after a power failure, the time of day is displayed. Then, the display selected last appears again.











31.1.5 Safety concept

The safety concept includes 3 choices to protect the controller against tampering:

- The functions or settings of function block "Locking functions" are locked on the software side.
Locking can be overridden (for details, refer to the chapter below).
- With the locking on the hardware side, overriding of locking on the software side can be prevented (refer to chapter 29.3 "Locking of locking functions level on the hardware side")
- The fixing screws on the controller front are recessed; the holes can be protected with a sealing label which is destroyed on removal

31.1.6 Setting levels and access rights

The operating lines are assigned to 3 different levels. Assignment and access are as follows:

Level	Operating lines	Access
End-user	1...50	Press  or  , then select the operating lines
Heating engineer	51...222	Press  and  for 3 seconds, then select the operating lines
Locking functions Code	226...251	<ol style="list-style-type: none"> 1. Press  and  simultaneously for 6 seconds 2. The display shows Cod 00000 3. The code consists of 5 buttons:      must be pressed in this order. 4. Select the operating lines. <p>For information about the code of OEM versions, contact the Siemens sales office nearest you.</p>

When changing to the next lower setting level, all settings of the higher setting level remain activated.

31.2 Commissioning

31.2.1 Installation instructions

The RVD260 is supplied complete with Installation Instructions. They provide detailed information about installation, wiring, commissioning, function checks and settings. The instructions address trained specialists. Each operating line has an empty field where the set value can be entered.

The Installation Instructions together with the plant's documentation should be kept in a safe place!

31.2.2 Operating lines

Operating line
"Plant type"

- The most important work to be performed when commissioning the plant is to enter the respective type of plant. This entry activates all functions and settings required for the plant
- In addition, further plant-specific variables are to be configured, for example:
 - Flow switch fitted/not fitted
 - Supply return of circulating pump
 - With/without:
 - speed-controlled pump
 - refill function
 - electric immersion heater and solar d.h.w. heating.

Setting the other
operating lines

All operating lines use factory-set, proven and practice-oriented values. Where required, codings, guide values, explanations, etc., are given in the Installation Instructions.

Operating lines for
functional checks

Function block "Test and display" contains 3 operating lines specifically suited for making function checks: Operating line 161 for the sensor test → the display shows the actual values acquired by the sensors

- Operating line 162 for the setpoints → the display shows the setpoints
- Operating line 163 for the relay test → output relays can be individually energized



If the display shows **Er**, the fault can be pinpointed via the error code on operating line 50.

31.3 Manual control

Manual control enables the heating system to be controlled manually during the commissioning phase or in the event of fault.

It is activated by pressing . The LED for manual control is lit and the LED for the operating mode extinguishes.

The control outputs are switched as follows:

- The power supply to the valves on the primary side (heating circuits or common flow) will be removed. They can be driven to any position by pressing  or 
- The other actuators are driven to their fully closed positions at 5 times the running time and then deenergized. The controller can no longer control the actuators (only manually, if the actuators feature manual control)
- The heating circuit, d.h.w. and intermediate circuit pump as well as the circulating and collector pump – if installed – are activated. The PWM output for speed-controlled pumps delivers the signal for 100%. The pump speeds on the data buses also are 100%
- The electric immersion heater is released and the refill valve remains fully closed or deenergized

The display shows the flow temperature of heating circuit 1 (B1).
During manual control, the control functions have no impact on the control outputs.
Manual control is deactivated by pressing  again or by pressing one of the operating mode buttons.
The manual control state can be ascertained but not changed via LPB. In any case, a heat request of 95 °C (fixed value) is sent to the heat source.

32 Engineering

32.1 Connection terminals

Low-voltage

DB	LPB
MB	Ground for LPB
A6	Room unit/room sensor PPS
MD	Ground for PPS
B9	Outside sensor
B1	Flow sensor heating circuit/common flow
M	Ground for sensors
B3	Flow sensor d.h.w.
B7/U2	Primary return sensor/primary pressure sensor
B71/U1	Secondary return sensor/secondary pressure sensor/external heat request
P1	Speed-controlled pump (PWM output)
M	Ground for sensors
B72	Primary/secondary return sensor/collector sensor
B31	d.h.w. storage tank sensor
B32	D.h.w. storage tank sensor/return sensor
M	Ground for sensors
B12	Flow sensor d.h.w. 2/flow sensor heating circuit
H5	Digital input (heat meter, flow switch, alarm contact, etc.)
CM+	M-bus
CM-	M-bus

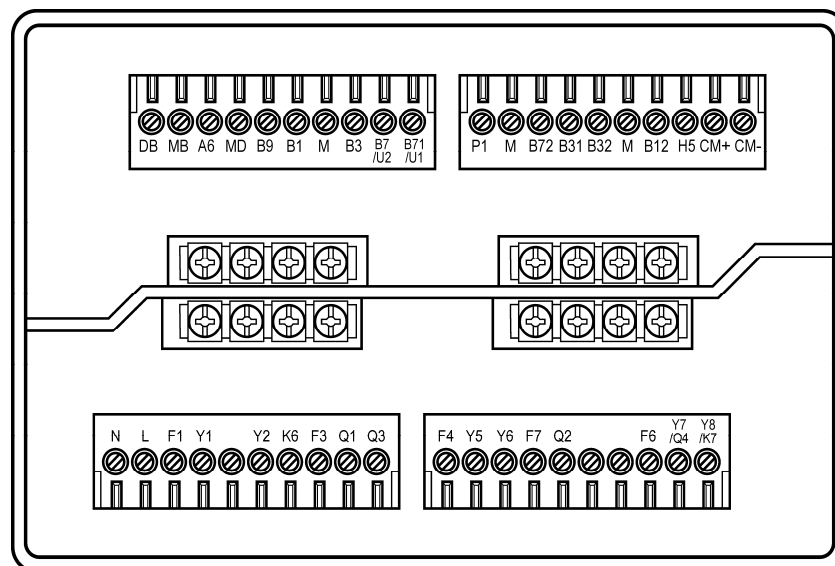

2513204

Mains voltage

N	Neutral conductor AC 230 V
L	Live AC 230 V
F1	Input for Y1 and Y2
Y1	Actuator of 2-port valve in the primary return OPEN
Y2	Actuator of 2-port valve in the primary return CLOSE
K6	Multifunctional output ON
F3	Input for Q1, Q3 and K6
Q1	Heating circuit pump ON
Q3	D.h.w. intermediate circuit/storage tank charging/circulating pump ON
F4	Input for Y5 and Y6
Y5	Actuator OPEN
Y6	Actuator CLOSE
F7	Input for Q2
Q2	Heating circuit pump ON
F6	Input for Y7/Q4 and Y8/K7
Y7/Q4	Actuator valve OPEN/storage tank charging pump ON
Y8/K7	Actuator valve CLOSE/multifunctional output ON

The base has 2 auxiliary terminals for ground connections and 2 additional auxiliary terminals, 1 for N and 1 for .

32.2 Installation

General notes:

- Local electrical safety regulations must be complied with
- The electrical installation must be made by qualified personnel
- The cable lengths should be chosen such that there is sufficient space to open the control panel door
- Cable strain relief must be ensured
- The cable glands used must be made of plastic
- The cables of the measuring circuits carry extra low-voltage
- The cables from the controller to the regulating unit and the pump carry mains voltage
- Sensor cables should not be run parallel to mains carrying cable
- A defective or damaged unit must immediately be disconnected from power
- The cores of the 2-wire cable to the PPS (room unit) are interchangeable

32.3 Relays

The maximum switching capacity of the relays used with plant types x-4 for switching the d.h.w. actuators is 24 VA. Greater loads shorten the contacts' service life.

32.4 PWM output

The PWM output is designed for safety extra low-voltage. The distance between the connected cable (device) and active components (e.g. AC 230 V) must satisfy the requirements for safety extra low-voltage.

32.5 Lightning protection in M-bus plants

Lightning can adversely affect the correct functioning of M-bus plants. For this reason, the following rules must be observed:

- If bus cables are laid outside buildings, the devices are exposed to transients of lightning strokes and must be appropriately protected
- Every bus cable and the devices to be protected demand matching protective equipment
- The protection function is ensured only if the installation is in proper working order

For notes on installation in compliance with EMC requirements, refer to Data Sheet N2034.

32.6 Connection diagrams

32.6.1 Low-voltage side

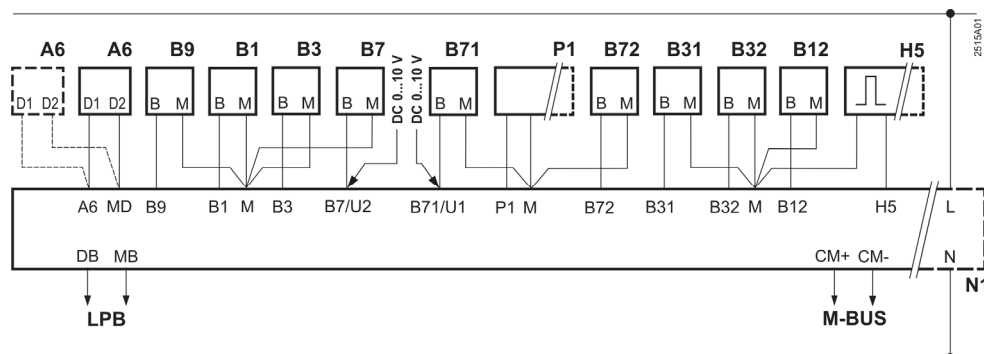

32.6.2 Mains voltage side

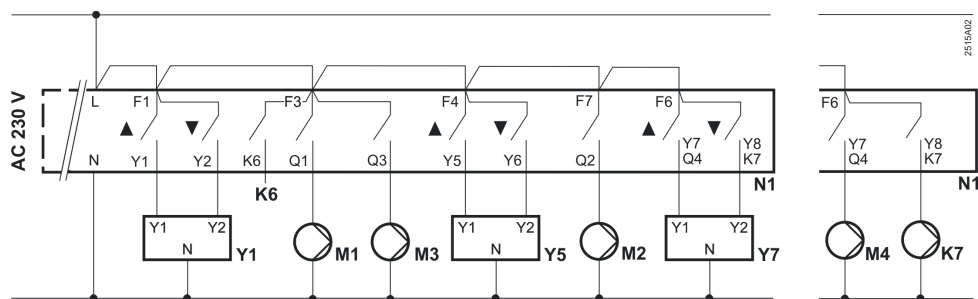

- A6 Room unit
- B1 Flow sensor heating circuit 1/common flow*
- B12 Flow sensor heating circuit 1/heating circuit 2*
- B3 Flow sensor d.h.w./heating circuit 2*
- B31 D.h.w. storage tank sensor
- B32 D.h.w. storage tank sensor/return sensor*
- B7 Primary return sensor **
- B71 Primary/secondary return sensor *
- B72 Primary/secondary return sensor/collector sensor
- B9 Outside sensor
- H5 Heat meter, flow switch, alarm contact, etc.
- Kx K6, K7 = multifunctional outputs for refill function/electric immersion heater/collector pump/circulating pump/flow alarm*
- N1 Controller RVD260
- P1 Speed-controlled pump (PWM output)
- M1 Heating circuit pump
- M2 Heating circuit pump
- M3 D.h.w. intermediate circuit/storage tank charging/circulating pump
- M4 Storage tank charging pump
- U1 Secondary pressure sensor/external heat request
- U2 Primary pressure sensor
- Y1 Actuator of 2-port valve in primary return
- Y5 Actuator*
- Y7 Actuator*
- * Depending on plant type
- ** For suppression of hydraulic creep

33 Mechanical design

33.1 Basic design

The RVD260 consists of controller insert and base. The controller insert contains the electronics, the power section and 10 relays. The base accommodates the connection terminals.

The front of the controller carries the operating elements and the backlit LCD. The Operating Instructions are inserted at the rear of the front cover. When the cover is closed, only the LCD can be seen.

The RVD260 has the standard overall dimensions 96 mm x 144 mm. It can be fitted in 1 of 3 different ways:

- Wall mounting
- Mounting on a top hat rail
- Flush-panel mounting; the front panel may have a maximum thickness of 3 mm

First, the base is mounted and wired. To ensure orientation will be correct, the upper side of both the base and the controller housing carry the marking TOP. Both top and bottom side of the base have 5 knockout holes for cable entry; there are 10 knockout holes in the floor.

The controller insert plugs into the base. It has 2 screws each of which is fitted with a lever. When, after fitting the controller insert, the screws are tightened, their levers engage in the openings in the base. When the screws are further tightened (alternately), the controller pulls itself into the base. The controller insert is thus secured to the base; at the same time, the electrical connections between controller insert and base are established.

To ensure reliable electrical connections, cable strain relief must be provided.

33.2 Mounting

33.2.1 Mounting location

Suitable mounting locations are compact stations, control panels, control desks or the heating room. Not permitted are damp or wet spaces.

At the selected location, the RVD260 can be fitted as follows:

- In a control panel, on an inner wall or on a top hat rail
- On a panel front
- In a control panel front
- In the sloping front of a control desk

All terminals for extra low-voltage (sensors and room units) are located at the top of the controller; those for mains voltage (actuators and pumps) at the bottom.

33.2.2 Mounting choices

The RVD260 can be mounted in 1 of 3 different ways:

- Wall mounting: The base is secured to a flat wall with 2 screws
- Rail mounting: The base is snapped on a top hat rail
- Flush-panel mounting: The base is fitted in a panel cutout measuring 138 x 92 mm; the front panel may have a maximum thickness of 3 mm

33.3 Dimensions

2515M01

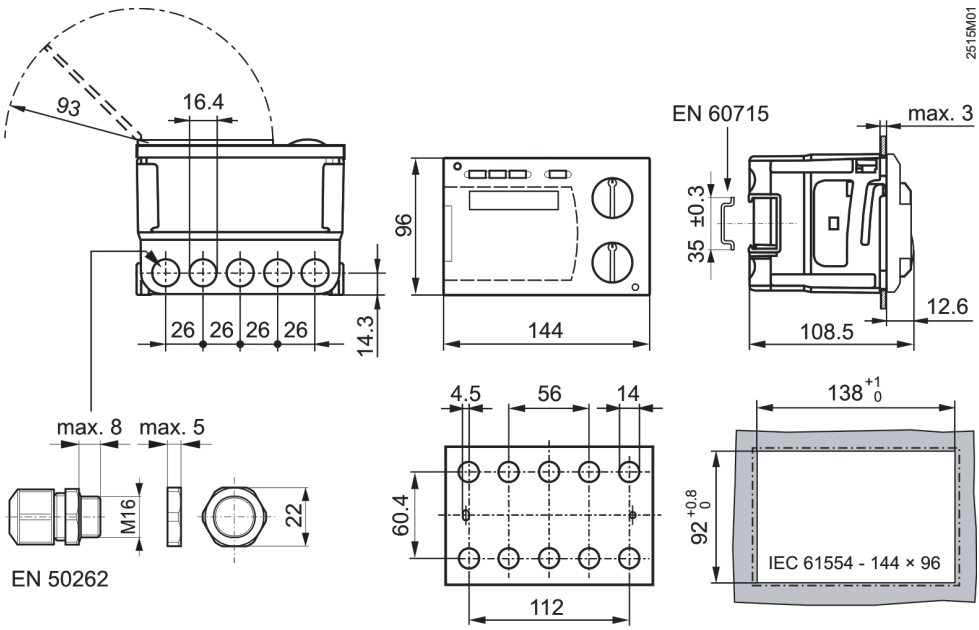

Dimensions in mm

34 Addendum

34.1 Technical data

For technical data, refer to Data Sheet N2515.

34.2 Revision history

Edition 1.0 is the first publication of this document.
For this reason, there is no need to list any alterations.

34.3 Index

A

Absolute priority.....	63
Access rights.....	121
Acquisition of measured values.....	24
Adaptation to the season.....	75
Addressing the devices.....	82
Addressing, M-bus.....	90
Assignment d.h.w. charging.....	77
Attenuated outside temperature.....	42, 49
Automatic 24-hour heating limit.....	50
Automatic ECO function.....	49
Automatic operation.....	23
Automatic summer/winter changeover.....	50

B

Baud rate, M-bus.....	90
Block jump function.....	120
Brauchwasserbereitung.....	23
Building time constant.....	42
Bus power supply, LPB.....	83

C

Cable lengths.....	125
Cable strain relief.....	125
Central power supply.....	83
Changeover winter-/summertime.....	89
Charging boost.....	74
Charging temp. solar maximum limitation.....	101
Child-proofing.....	76
Circulating pump.....	37
Coil type storage tank.....	13
Collector off temperature.....	101
Collector pump running hot.....	100
Collector sensor.....	27
Collector start function.....	101
Collector temperature.....	97
Combination with PPS devices.....	114
Commissioning.....	122
Compensating and aux. variables, autom. ECO.....	49
Compensating variables.....	42
Compensation of heat losses, direct d.h.w.....	71
Composite outside temperature.....	42
Composite outside temperature.....	49
Connection diagrams.....	126
Connection terminals.....	124
Continuous operation.....	23
Control of circulating pump.....	62
Control of intermediate circuit pump.....	40
Control outputs with manual control.....	122
Control process.....	57
Control process heating circuit.....	59
Control process, d.h.w.circuit.....	73

Controller in unoperated state.....	120
Cooling down characteristic.....	51
Critical locking signals.....	84
Current outside temperature.....	42, 49

D

D.h.w. assignment.....	77
D.h.w. charging with 2 storage tank sensors.....	74
D.h.w. flow sensor.....	25
D.h.w. functions.....	18
D.h.w. heating.....	69
D.h.w. heating via heat exchanger.....	70
D.h.w. heating with storage tanks.....	66
D.h.w. heating with stratification storage tank.....	69
D.h.w. priority.....	63
D.h.w. program.....	32
D.h.w. storage tank sensor.....	26
D.h.w. switching program.....	32
Deviation in the room.....	48
Dimensions.....	128
Direct d.h.w. Monitoring overtemperature.....	88
Monitoring undertemperature.....	88
Display D.h.w.temperature.....	33
Flow temperature heating circuit.....	33
Outside temperature.....	33
Room temperature.....	33
Display of digital input.....	94
Display of limitations.....	95
Display of pump speed.....	94
Display of setpoint.....	45
District heating network parameters.....	106
DRT and maximum limitation of return temp.....	106
DRT function.....	109
Duration of d.h.w. charging.....	67
Dwelling time (legionella function).....	78

E

Early shutdown.....	51
Electric immersion heater.....	68
Energy/volumetric flow pulses.....	110
Engineering.....	124
Entries for LPB.....	82
Entry of holidays, QAW70.....	117
Error code.....	35
Evaporation temp. of heat conducting medium.....	100
External heat demand.....	58
External heat demand (H5).....	58
Extra functions.....	18
Extra low-voltage.....	127

F			
Feeding the circulating water	69	Heat demand signal (H5)	58
Flow alarm	87	Heat exchanger	13
Flow sensor	24	Heating circuit control	48
Flow switch	71	Heating circuit functions	17
Flow temperature boost	74	Heating curve	44
Flush-panel mounting	127	Heating limit	50
Forced charging	68	Heating period	47
Forward shift	53	Heating periods	30
Freely programmable input	117	Heating program	30
Frost protection for collector	98	Heating up brake	54
Frost protection for d.h.w.	65	Heating up characteristic	51
Frost protection for heating circuit flow	87	Heating up time	51
Frost protection for the building	54	Holiday mode	34
Frost protection for the plant	86	Holiday mode, setpoint	29
Frost protection function solar	98	Holiday period	34
Function		Holiday program	34
D.h.w. (end-user)	32	I	
Display of faults (end-user)	35	Increase flow temperature setpoint	54
Display of sensors values (end-user)	33	Increase of reduced setpoint	111
Holiday settings (end-user)	34	Input H5	38
Setting the clock (end-user)	31	Installation instructions	122
Space heating (end-user)	29	Integral action time, limit functions	109
Function block		Interconnected plant	82
Assignment of d.h.w.	77	Intermediate circuit pump	13
D.h.w. heating	61	Intermediate circuit pump, overrun	65
Device functions	86	Intermediate season, ECO function	49
DRT and maximum limitation of return temp.	106	K	
Extra legionella functions	78	Key features	20
LPB parameters	82	Knob, QAW50	115
M-bus parameters	90	Knob, QAW70	116
Miscellaneous	110	L	
Multifunctional relays	81	Legionella function	62, 78
Operation locking functions	113	Legionella setpoint	78
Plant configuration	36	Legionella weekday	78
PPS parameters	92	Lightning protection	125
Refill functions	103	Limit function input H5	110
Solar d.h.w.	96	Limitations, display	95
Space heating	42	Load limit	75
Test and display	93	Load Management	90
Valve actuator d.h.w.	73	Locking on the hardware side	113
Valve actuator heat exchanger	57	Locking on the software side	113
Valve actuator space heating	59	Locking signals	84
Function blocks (list)	20	Locking time	111
Function check	122	Low-voltage	124
G		Low-voltage side	126
Gain factor, influence of room temperature	43	LPB parameters	82
Generation of setpoint	45	M	
Gradient collector start function	101	Mains voltage	124, 127
H		Mains voltage side	126
H5 input	38	Manual control	122
Handbetrieb	23	Manual d.h.w. charging	65, 79
Heat demand signal	58		

Manual storage tank charging	67
Master clock	82
Max. limitation in heating mode	107
Max. limitation of charging temperature solar	101
Max. limitation of flow temperature heating circuit	59
Max. limitation of primary return temp. in d.h.w. mode	107
Max. limitation of primary return temperature	106
Max. limitation of return temperature differential	109
Max. limitation of secondary return temperature	108
Max. limitation of storage tank temperature	101
Maximum limitation flow temperature	57
Maximum limitation of room temperature	50
Maximum limitation setpoint increase	54
Maximum rate of flow temperature increase	54
Maximum refill period per charging cycle	105
Maximum refill period per week	105
Maximum setpoint for d.h.w. temperature	74
M-bus parameters	90
Min. limitation of flow temperature heating circuit	60
Minimum and maximum speed	38
Minimum charging temperature solar	97
Minimum limitation of flow temperature	58
Minimum limitation of stroke	111
Minimum running time collector pump	98
Minimum secondary underpressure period	104
Mode of operation frost protection for the building	54
Mode of operation of ECO function	50
Mounting choices	127
Mounting location	127

N

No priority (d.h.w. charging)	64
Nominal d.h.w. setpoint	32
Nominal setpoint	29
Non-occupancy time	53

O

Occupancy time	53
Operating line principle	120
Operating lines	122
Operating lines, QAW70	116
Operating modes	23
Operation of circulating pump (legionella function)	79
Optimization	51
Optimum start control	53
Optimum stop control	53
Outside sensor	24
Outside temperature reset	42
Outside temperature source	83
Overlapping heating periods	30
Overlapping holiday periods	34
Overriding the operating mode, QAW50	115
Overriding the operating mode, QAW70	116

Overrun, d.h.w. circuit	65
Overrun, heating circuit	50
Overrun, pump and mixing circuit	56
Overtemp. protection for the collector	99
Overtemperature protection	55
Overview of functions refill	104

P

Parallel displacement, heating curve	48
Parallel operation (d.h.w. charging)	64
Pivotal point, heating curve	44
Plant configuration	36
Plant type	36
Plant types	20
Plants with coil type storage tanks	66
Plants with stratification storage tanks	66
PPS 2-wire line	125
PPS parameters	92
Pressure sensors	28
Primary pressure sensor U2	105
Primary return temp. maximum limitation	106
Priority of d.h.w. charging	63
Product documentation	16
Proportion of heat gains	49
Protection	23
Protection against cooling down	70
Protection against discharging	68
Protection against overtemp. storage tank charging	68
Pulse lock	86
Pulses at H5	94
Pulse-width-modulated output	38
Pump kick	55
Pump overrun, d.h.w. circuit	65
Pump overrun, heating circuit	50
Pump overrun, pump and mixing circuit	56
PWM output	38, 125

Q

QAW70 operating lines	116
Quick setback	53

R

Rail mounting	127
Recooling storage tank (solar)	99
Reduced d.h.w. setpoint	32
Reduced setpoint	29
Refill function	103
Refill locking time	104
Relative secondary minimum pressure	104
Relay test	94
Relays	125
Release of d.h.w. charging	61
Release phases d.h.w. program	32
Resetting the counters, refill function	105

Resolution, M-bus signals.....	91	Storage tank with electric immersion heater	68
Return sensor	26, 27	Stored heat.....	49
Return temperature differential	109	Stratification storage tank.....	13, 69
Room model.....	25, 30	Suitable actuators	15
Room model temperature	52	Suitable room units	15
Room sensor QAA10	118	Suitable sensors.....	15
Room sensor QAW44	117	Summer, ECO function	49
Room sensors.....	25	Summertime	89
Room temperature	43	Suppression of hydraulic creep.....	111
Room temperature-compensated control	48	Switching d.h.w. heating on and off	65, 79
Room temperature-compensated flow temp. control	43	Switching differential d.h.w control.....	62
Room unit QAW50.....	114	Switching differential refill function	104
Room unit QAW70.....	115		
Room units.....	25	T	
Roominfluence	48	Telephone contact.....	117
		Temperature differential solar	97
S		Test and display	93
Safety concept	121	Time (legionella function)	78
Secondary pressure sensor U1	105	Type of building construction	42
Secondary underpressure period.....	104	Type summary	14
Seizing	55	Types of heating systems	17
Sensor test.....	93	Types of houses and buildings.....	17
Setpoint		Types of plant.....	17
Room temperature-compensated control	46		
Weather-compensated control	45	U	
Weather-compensated control with room influence	47	Uncritical locking signals	85
Setpoint boosts	74	Unoperated state.....	120
Setpoint for frost protection.....	29, 54		
Setpoint for legionella function.....	63	V	
Setpoint increase	54	Valve actuator d.h.w.....	73
Setpoint test.....	93	Valve kick	55
Setting knob, controller	29		
Setting level	121	W	
Shifting priority	64	Waiting time, protection against cooling down	70
Shutdown of pump	55	Wall mounting.	127
Siting the sensors, d.h.w. heating	71	Weather-compensated control	43, 48
Slope of heating curve	44	Weather-compensated control with room influence	48
Software version	95	Weekday for legionella function	62
Solar charging, temperature differential.....	97	Window contact.....	117
Source of time of day	82	Wintertime	89
Space heating	42	Wiring	122
Speed-controlled pump.....	38		
Storage tank charging pump.....	13, 65	Y	
Storage tank recooling (solar).....	99	Yearly clock.....	31

Siemens Switzerland Ltd
Industry Sector
Building Technologies Division
Gubelstrasse 22
CH 6301 Zug
Tel. +41 41 724 24 24
www.siemens.com/sbt

© 2010 Siemens Switzerland Ltd
Subject to change