

Approval body for construction products
and types of construction

Bautechnisches Prüfamnt

An institution established by the Federal and
Laender Governments



European Technical Assessment

ETA-14/0130
of 17 June 2014

General Part

Technical Assessment Body issuing the
European Technical Assessment:

Trade name of the construction product

Product family
to which the construction product belongs

Manufacturer

Manufacturing plant

This European Technical Assessment
contains

This European Technical Assessment is
issued in accordance with Regulation (EU)
No 305/2011, on the basis of

Deutsches Institut für Bautechnik

EJOT H3

Nailed-in plastic anchor with plastic pin for fixing of
external thermal insulation composite systems with
rendering in concrete and masonry.

EJOT Baubefestigungen GmbH
In der Stockwiese 35
57334 Bad Laasphe
DEUTSCHLAND

EJOT Herstellwerke 1, 2, 3, 4

12 pages including 8 annexes which form an integral part
of this assessment

Guideline for European technical approval of "Plastic
anchors for fixing of external thermal insulation composite
systems with rendering", ETAG 014, Edition February
2011,
used as European Assessment Document (EAD)
according to Article 66 Paragraph 3 of Regulation (EU)
No 305/2011.

The European Technical Assessment is issued by the Technical Assessment Body in its official language. Translations of this European Technical Assessment in other languages shall fully correspond to the original issued document and shall be identified as such.

Communication of this European Technical Assessment, including transmission by electronic means, shall be in full. However, partial reproduction may only be made with the written consent of the issuing Technical Assessment Body. Any partial reproduction has to be identified as such.

This European Technical Assessment may be withdrawn by the issuing Technical Assessment Body, in particular pursuant to information by the Commission according to Article 25 Paragraph 3 of Regulation (EU) No 305/2011.

Specific part

1 Technical description of the product

The nailed-in anchor EJOT H3 consists of a plastic part made of polyethylene and an accompanying specific nail of polyamide, reinforced with glass fibres.

The anchor types EJOT H3 may in addition be combined with the insulation discs SBL 140 plus and VT 90.

The product description is given in Annex A.

2 Specification of the intended use in accordance with the applicable European Assessment Document

The performances given in Section 3 are only valid if the anchor is used in compliance with the specifications and conditions given in Annex B.

The verification and assessment methods on which this European Technical Assessment is based lead to the assumption of a working life of the anchor of at least 25 years. The indications given on the working life cannot be interpreted as a guarantee given by the producer, but are to be regarded only as a means for choosing the right products in relation to the expected economically reasonable working life of the works.

3 Performance of the product and references to the methods used for its assessment

3.1 Mechanical resistance and stability (BWR 1)

The essential characteristics regarding mechanical resistance and stability are included under the Basic Works Requirement Safety in use.

3.2 Safety in case of fire (BWR 2)

Not applicable.

3.3 Hygiene, health and the environment (BWR 3)

Regarding dangerous substances there may be requirements (e.g. transposed European legislation and national laws, regulations and administrative provisions) applicable to the products falling within the scope of this European Technical Assessment. In order to meet the provisions of Regulation (EU) No 305/2011, these requirements need also to be complied with, when and where they apply.

3.4 Safety in use (BWR 4)

Essential characteristic	Performance
Characteristic resistance	See Annex C 1
Edge distances and spacing	See Annex B 2
Point thermal transmittance	See Annex C 2
Plate stiffness	See Annex C 2
Displacements	See Annex C 2

3.5 Protection against noise (BWR 5)

Not applicable.

3.6 Energy economy and heat retention (BWR 6)

Not applicable.

3.7 Sustainable use of natural resources (BWR 7)

The sustainable use of natural resources was not investigated.

3.8 General aspects

The verification of durability is part of testing the essential characteristics. Durability is only ensured if the specifications of intended use according to Annex B are taken into account.

4 Assessment and verification of constancy of performance (AVCP) system applied with reference to its legal base

According to Decision 97/463/EC of the Commission of 27 June 1997 (Official Journal of the European Communities L 198 of 25.07.1997, p. 31–32) the system of assessment and verification of constancy of performance (AVCP) (see Annex V and Article 65 Paragraph 2 to Regulation (EU) No 305/2011) given in the following table applies.

Product	Intended use	Level or class	System
Plastic anchors for use in concrete and masonry	For use in systems, such as façade systems, for fixing or supporting elements which contribute to the stability of the systems	—	2+

5 Technical details necessary for the implementation of the AVCP system, as provided in the applicable European Assessment Document

Technical details necessary for the implementation of the AVCP system are laid down in the control plan deposited at Deutsches Institut für Bautechnik.

Issued in Berlin on 17 June 2014 by Deutsches Institut für Bautechnik

Dr. Karsten Kathage
Vice-President

beglaubigt:
Aksünger

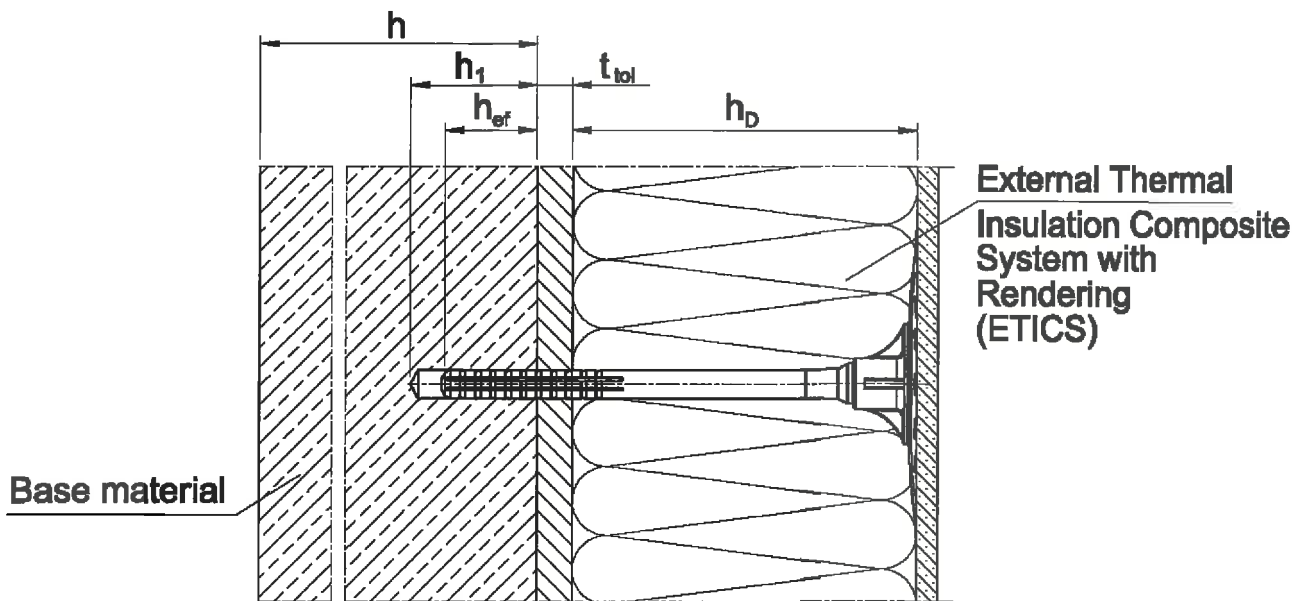

- Legend:
- h_D = thickness of insulation material
 - h_{ef} = effective anchorage depth
 - h = thickness of member (wall)
 - h_1 = depth of drilled hole to deepest point
 - t_{tol} = thickness of equalizing layer or non-load-bearing coating

EJOT H3	Annex A 1
Product description Installed condition	

EJOT H3

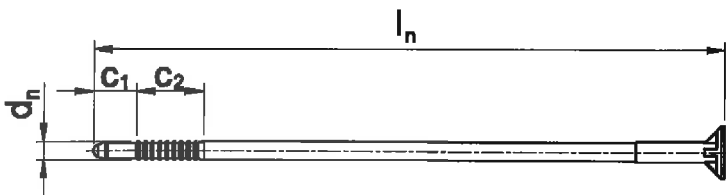
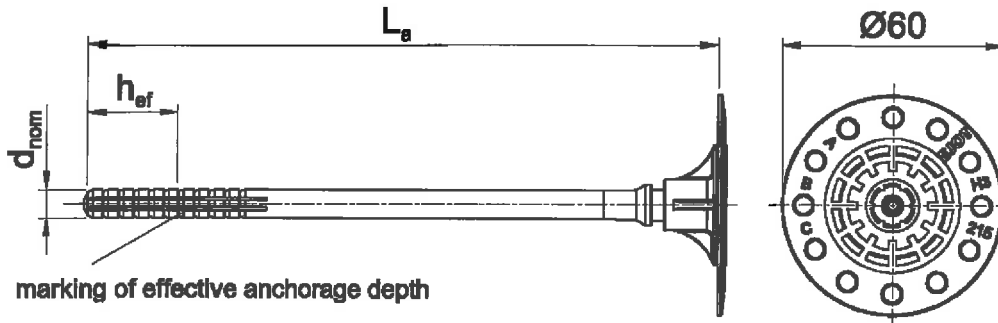

accompanying specific nail

Marking:
Identifying mark (EJOT)
Anchor type (H3)
Length of anchor (e.g. 215)

Table A1: Dimensions

Anchor Type	Colour	Anchor sleeve			Specific nail		
		d_{nom} [mm]	h_{ef} [mm]	min L_a max L_a [mm]	d_n [mm]	C_1 [mm]	C_2 [mm]
EJOT H3	nature	8	25	75 235	5	12	18

Determination of maximum thickness of insulation h_{Dmax} [mm] for EJOT H3:

$$h_{Dmax} = L_a - t_{tol} - h_{ef} \quad (L_a = \text{e.g. } 75; t_{tol} = 10)$$

e.g. $h_{Dmax} = 75 - 10 - 25$
 $h_{Dmax} = 40$

EJOT H3

Product description
Marking and dimensions of the anchor sleeve
Specific nail

Annex A 2

Table A2: Materials

Name	Materials
Anchor sleeve	Polyethylene, PE-HD
Specific nail	Polyamide, PA GF 50

SBL 140 plus

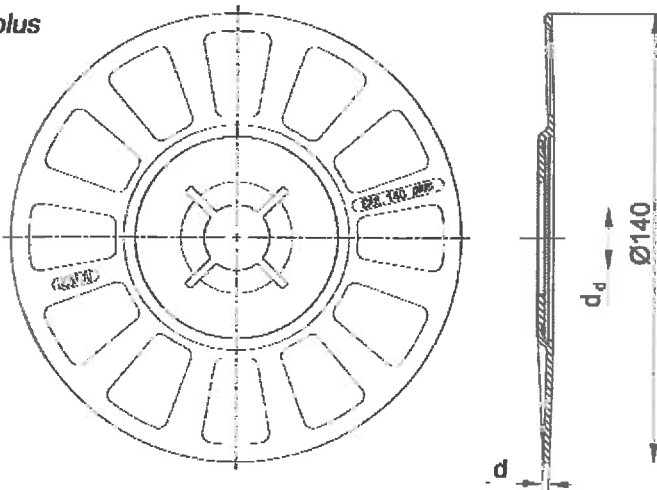

SBL 140 plus	
colour	nature
d _d [mm]	20,0
d [mm]	2,0
Material	1) 2)

VT 90

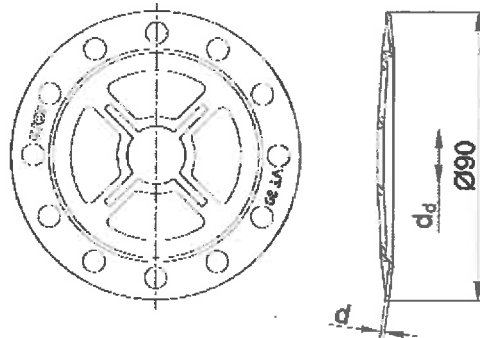

VT 90	
colour	nature
d _d [mm]	17,5
d [mm]	1,2
Material	1) 2)

- 1) Polyamide, PA 6
2) Polyamide, PA GF 50

EJOT H3

Product description
Materials,
Slip on plates combined with EJOT H3

Annex A 3

Specifications of intended use

Anchorage subject to:

- The anchor may only be used for transmission of wind suction loads and shall not be used for the transmission of dead loads of the thermal insulation composite system.

Base materials:

- Normal weight concrete (use category A) according to Annex C1.
- Solid masonry (use category B), according to Annex C1.
- Hollow or perforated masonry (use category C), according to Annex C1.
- For other base materials of the use categories A, B, or C the characteristic resistance of the anchor may be determined by job site tests according to ETAG 014 Edition February 2011, Annex D.

Temperature Range:

- 0°C to +40°C (max. short term temperature +40°C and max. long term temperature +24°C)

Design:

- The anchorages are designed in accordance with the ETAG 014 Edition February 2011 under the responsibility of an engineer experienced in anchorages and masonry work.
- Verifiable calculation notes and drawings are prepared taking account of the loads to be anchored. The position of the anchor is indicated on the design drawings.
- Fasteners are only to be used for multiple fixings of thermal insulation composite systems.

Installation:

- Hole drilling by the drill modes according to Annex C1.
- Anchor installation carried out by appropriately qualified personnel and under the supervision of the person responsible for technical matters of the site.
- Installation temperature from 0°C to +40°C
- Exposure to UV due to solar radiation of the anchor not protected by rendering ≤ 6 weeks

EJOT H3

Intended use
Specifications

Annex B 1

Table B1: Installation parameters

Anchor type		EJOT H3
Drill hole diameter	d_0 [mm] =	8
Cutting diameter of drill bit	d_{cut} [mm] ≤	8,45
Depth of drilled hole to deepest point	h_1 [mm] ≥	35
Effective anchorage depth	h_{ef} [mm] ≥	25

Table B2: Anchor distances and dimensions of members

Anchor type		EJOT H3
Minimum allowable spacing	s_{min} = [mm]	100
Minimum allowable edge distance	c_{min} = [mm]	100
Thickness of member	h ≥ [mm]	100

Scheme of distances and spacing

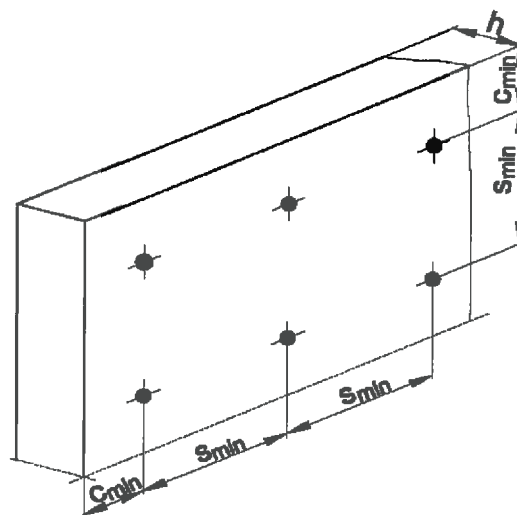

EJOT H3

Intended use
Installation parameters,
Edge distances and spacing

Annex B 2

Installation instructions

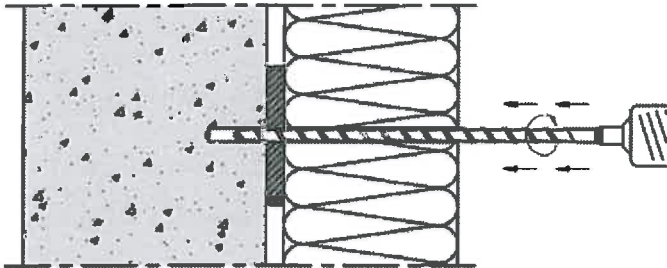

Drill the hole perpendicular to the substrate surface. Clean the drill hole 3x.

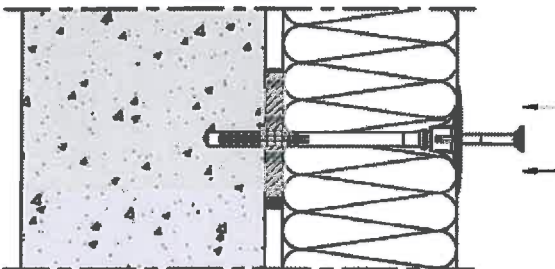

Place the anchor into the drill hole.
The bottom side of the plate must be flush with the ETICS.

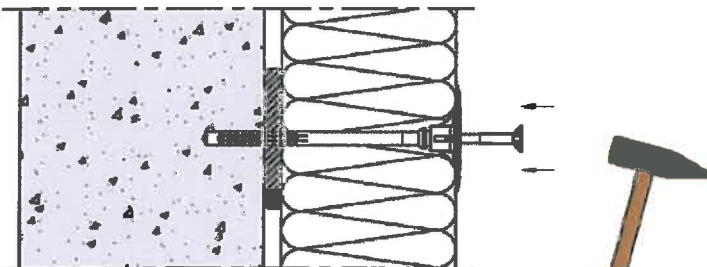

Drive in die specific nail with the hammer.

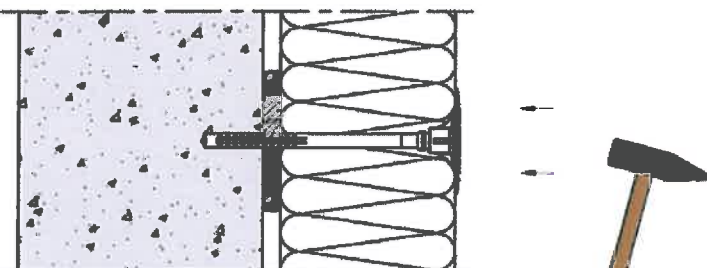

Installed condition of EJOT H3.

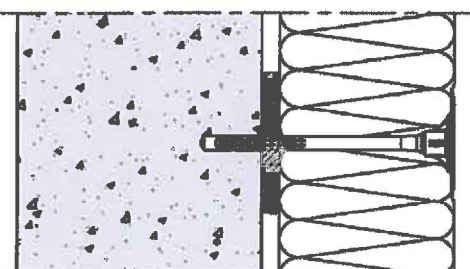

EJOT H3

Intended use
Installation instructions

Annex B 3

Table C1: Characteristic resistance to tension loads N_{Rk} in concrete and masonry for a single anchor in kN					
Anchor type					EJOT H3
Base materials	Bulk density class ρ [kg/dm ³]	minimum compressive strength f_b [N/mm ²]	General remarks	Drill methode	N_{Rk} [kN]
Concrete C20/25			EN 206-1:2000	hammer	0,6
Concrete C50/60			EN 206-1:2000	hammer	0,6
Clay bricks, Mz e.g. according to DIN 105-100:2012-01 / EN 771-1:2011	$\geq 1,8$	12	Cross section reduced up to 15 % by perforation vertically to the resting area	hammer	0,6
Sand-lime solid bricks, KS e.g. according to DIN V 106:2005-10 / EN 771-2:2011	$\geq 1,8$	12	Cross section reduced up to 15 % by perforation vertically to the resting area	hammer	0,6
Vertically perforated solid blocks, HLz e.g. according to DIN 105-100:2012-01 / EN 771-1:2011	$\geq 0,8$	12	Cross section reduced by more than 15% and less than 50% by perforation vertically to the resting area	rotary	0,5 ¹⁾
Vertically perforated solid blocks, HLz e.g. according to DIN 105-100:2012-01 / EN 771-1:2011	$\geq 1,2$	20	Cross section reduced by more than 15% and less than 50% by perforation vertically to the resting area	rotary	0,6 ²⁾
Sand-lime perforated bricks, KSL e.g. according to DIN V 106:2005-10 / EN 771-2:2011	$\geq 1,6$	12	Cross section reduced by more than 15 % by perforation vertically to the resting area	rotary	0,6 ³⁾
EJOT H3					Annex C 1
Performances Characteristic resistance					

- ¹⁾ The value applies only for outer web thickness ≥ 11 mm; otherwise the characteristic resistance shall be determined by job site pull-out tests.
- ²⁾ The value applies only for outer web thickness ≥ 14 mm; otherwise the characteristic resistance shall be determined by job site pull-out tests.
- ³⁾ The value applies only for outer web thickness ≥ 20 mm; otherwise the characteristic resistance shall be determined by job site pull-out tests.

Table C2: Point thermal transmittance according EOTA Technical Report TR 025:2007-06

anchor type	insulation thickness h_d [mm]	point thermal transmittance χ [W/K]
EJOT H3	40 - 200	0,000

Table C3: Plate stiffness according EOTA Technical Report TR 025:2007-06

anchor type	diameter of the anchor plate [mm]	load resistance of the anchor plate [kN]	plate stiffness [kN/mm]
EJOT H3	60	1,25	0,6

Table C4: Displacements

Base materials	Bulk density Class ρ [kg/dm ³]	Minimum Compressive strength f_b [N/mm ²]	Tension load N [kN]	Displacements $\delta_m(N)$ [kN/mm]
Concrete C20/25			0,2	0,55
Concrete C50/60			0,2	0,34
Clay bricks, Mz e.g. according to DIN 105-100:2012-01 / EN 771-1:2011	≥ 1,8	12	0,2	0,31
Sand-lime solid bricks, KS e.g. according to DIN V 106:2005-10 / EN 771-2:2011	≥ 1,8	12	0,2	0,33
Vertically perforated solid blocks, HLz e.g. according to DIN 105-100:2012-01 / EN 771-1:2011	≥ 0,8	12	0,16	0,25
Vertically perforated solid blocks, HLz e.g. according to DIN 105-100:2012-01 / EN 771-1:2011	≥ 1,2	20	0,2	0,27
Sand-lime perforated bricks, KSL e.g. according to DIN V 106:2005-10 / EN 771-2:2011	≥ 1,6	12	0,2	0,24

EJOT H3

Performances
Point thermal transmittance, plate stiffness and displacements

Annex C 2