

Universal Condensate Pump

Combi

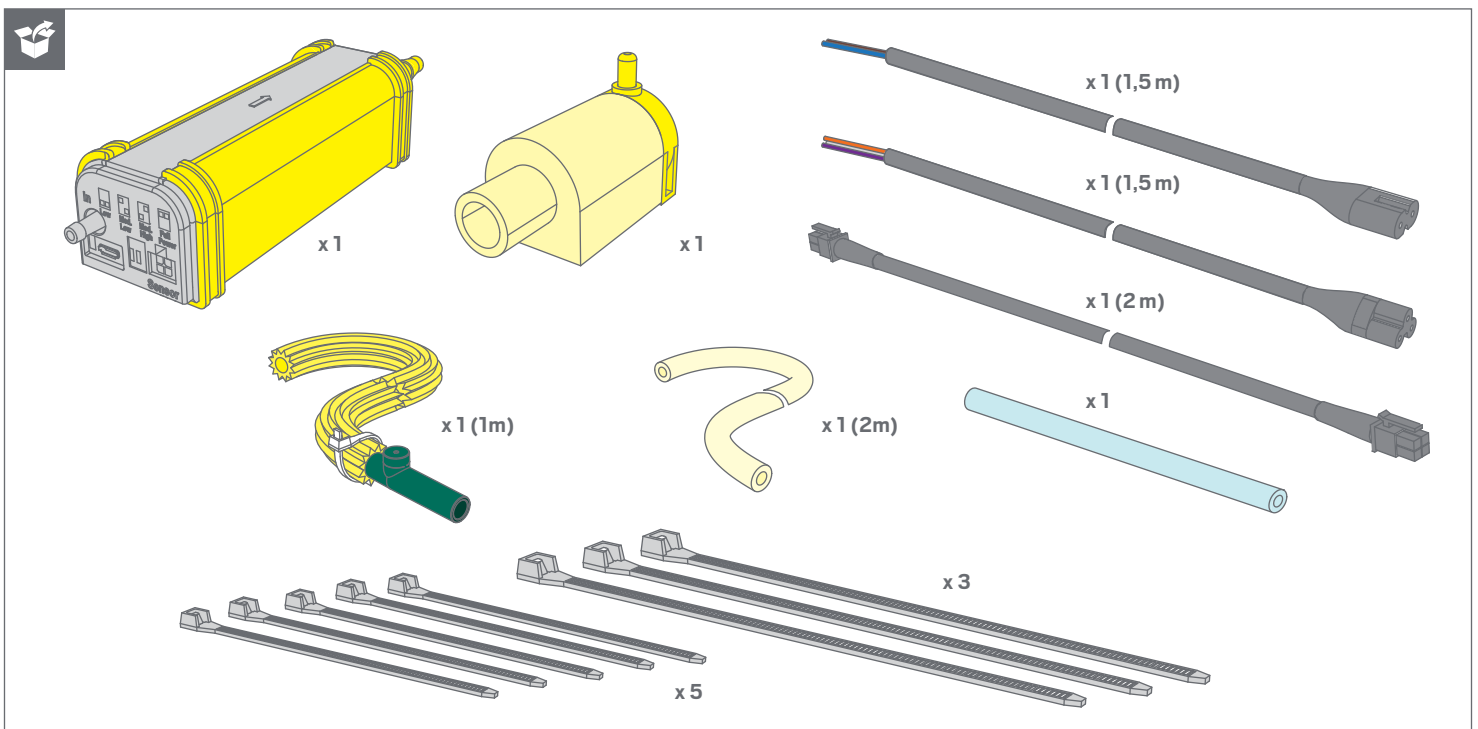

1

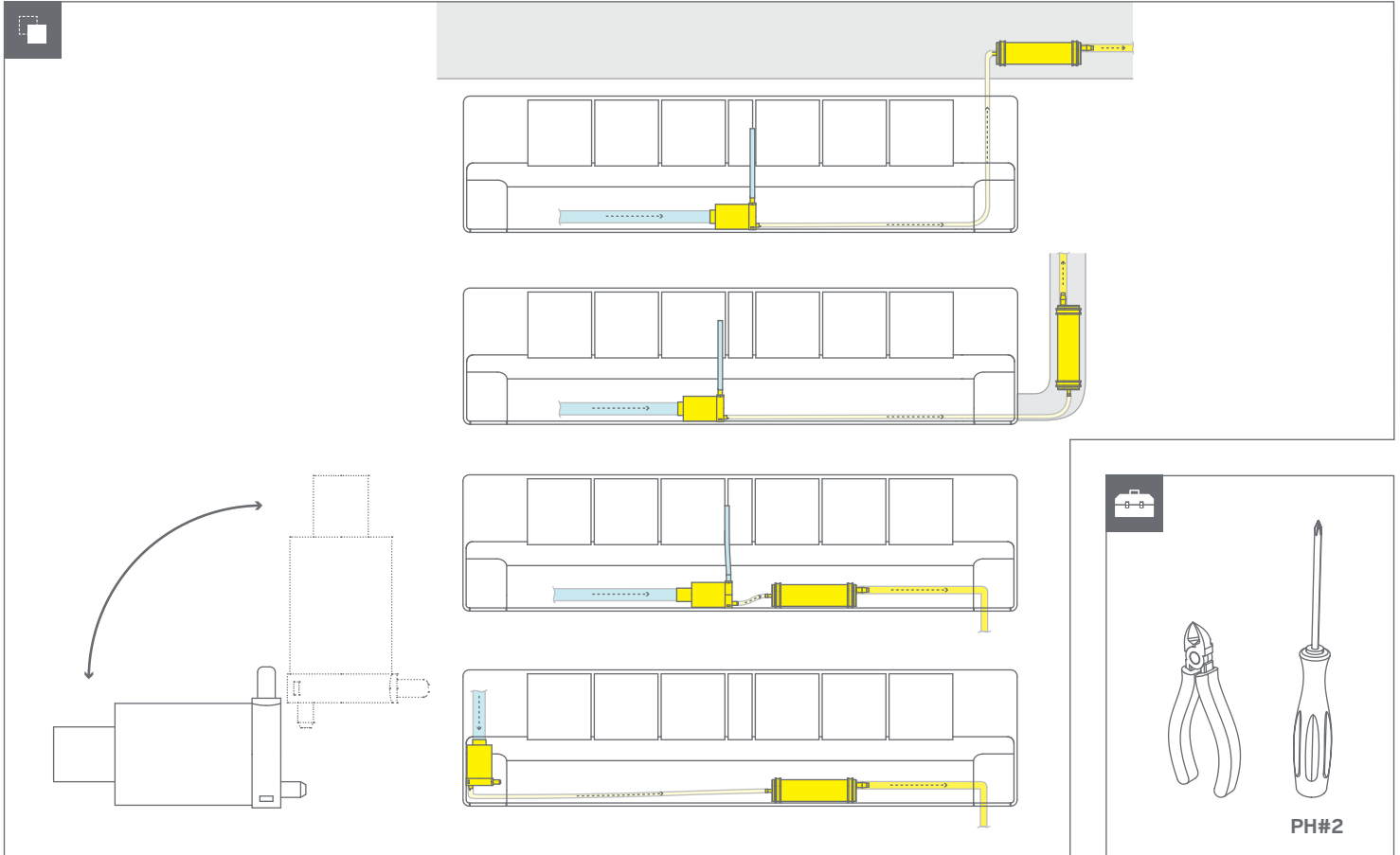
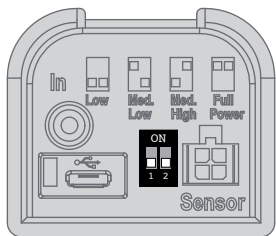
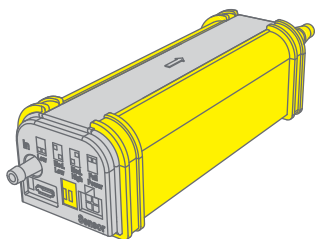

Low
up to 18K Btu/h
(5.3kW)



Medium Low
up to 42K Btu/h
(12kW)



Medium High
up to 72K Btu/h
(21.1kW)



Full Power
up to 120K Btu/h
(35kW)

2

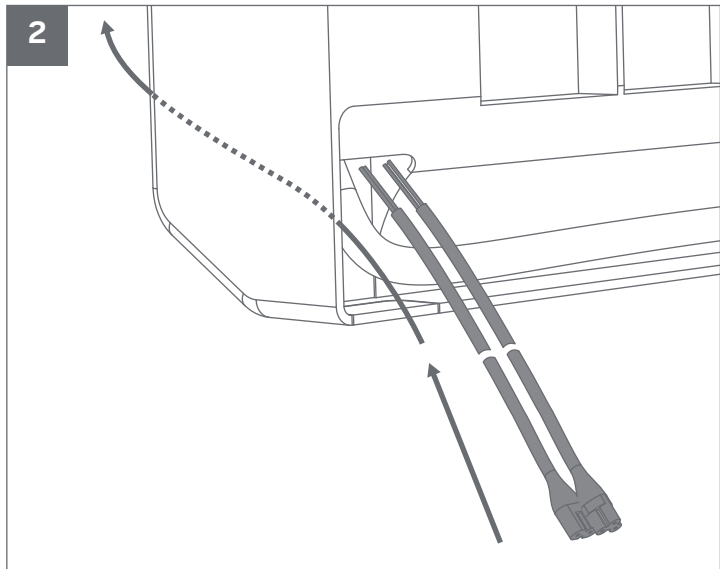

3

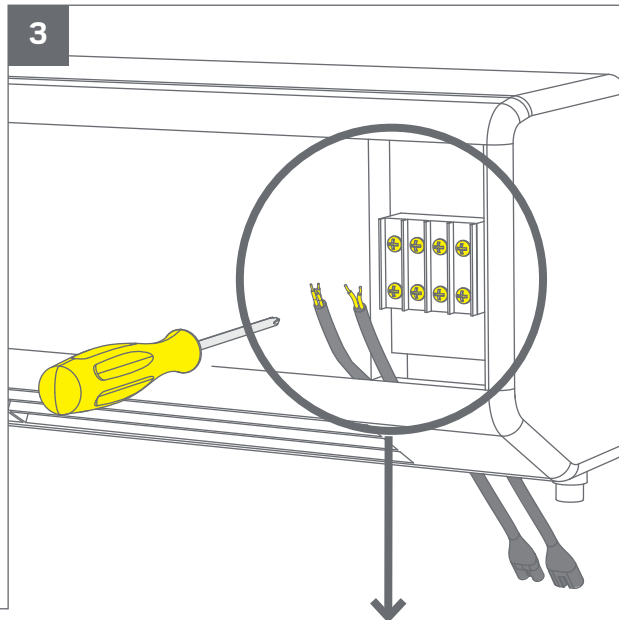

When Indoor Evaporator Unit is powered from the Outdoor Condenser Unit.

Below examples are for reference only.

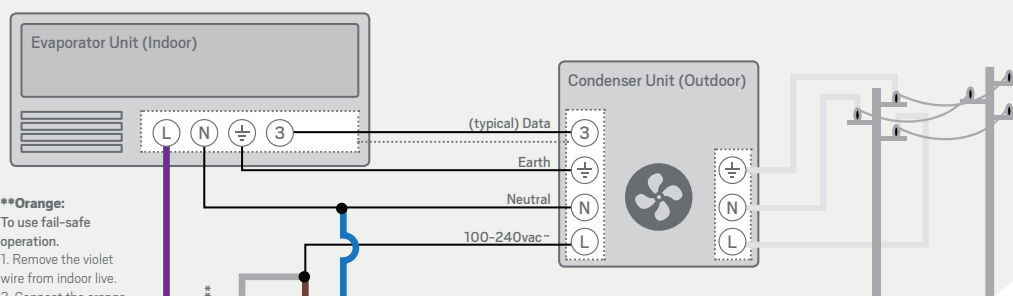

****Orange:**
To use fail-safe operation.
1. Remove the violet wire from indoor live.
2. Connect the orange wire to indoor live.
3. Change alarm relay to fail-safe operation.

Alarm Relay Operation Table

Power Up LED Sequence			
Pump Status	Condensate Level	Default Operation	Fail-Safe Operation
Unpowered	N/A		
Powered	Below Alarm Level		
Powered	Alarm-Activated		

To change Alarm Relay Operation:

- Unplug pump
- Move DIP switch positions to
- Plug pump in
- Wait for one green LED blink
- Move DIP switch positions to
- Wait for one red LED blink
- Reset DIP switch positions to
- Wait for one green LED blink
- Unplug pump
- Set the DIP switches back to the desired capacity configuration. (Low, Medium-Low, Medium-High, High)
- Plug Pump in and check that power up LED sequence matches the desired alarm relay operation
- Done.

To reset default alarm relay operation repeat steps 1 thru 11.

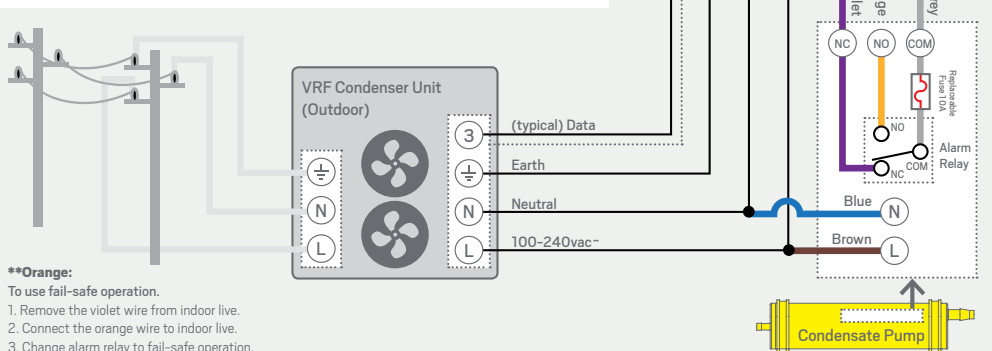

****Orange:**
To use fail-safe operation.
1. Remove the violet wire from indoor live.
2. Connect the orange wire to indoor live.
3. Change alarm relay to fail-safe operation.

4a

Horizontal installation

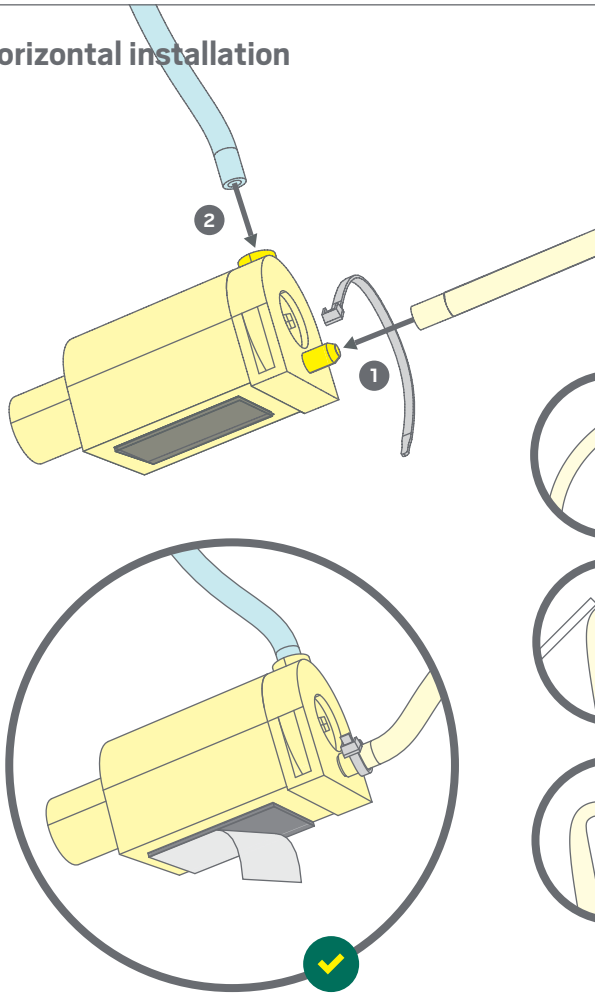

4b

Vertical installation

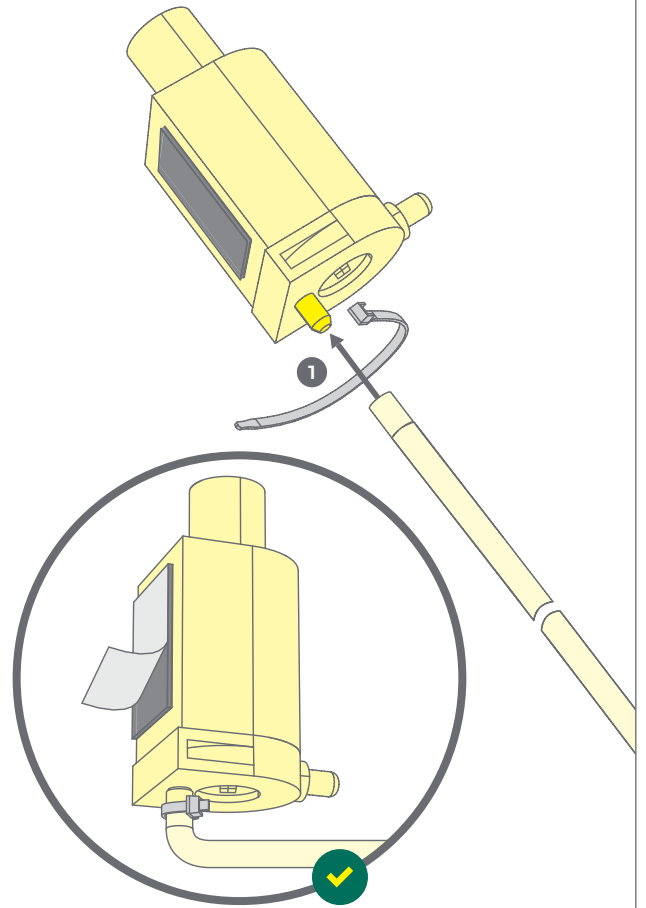

5a

Horizontal installation

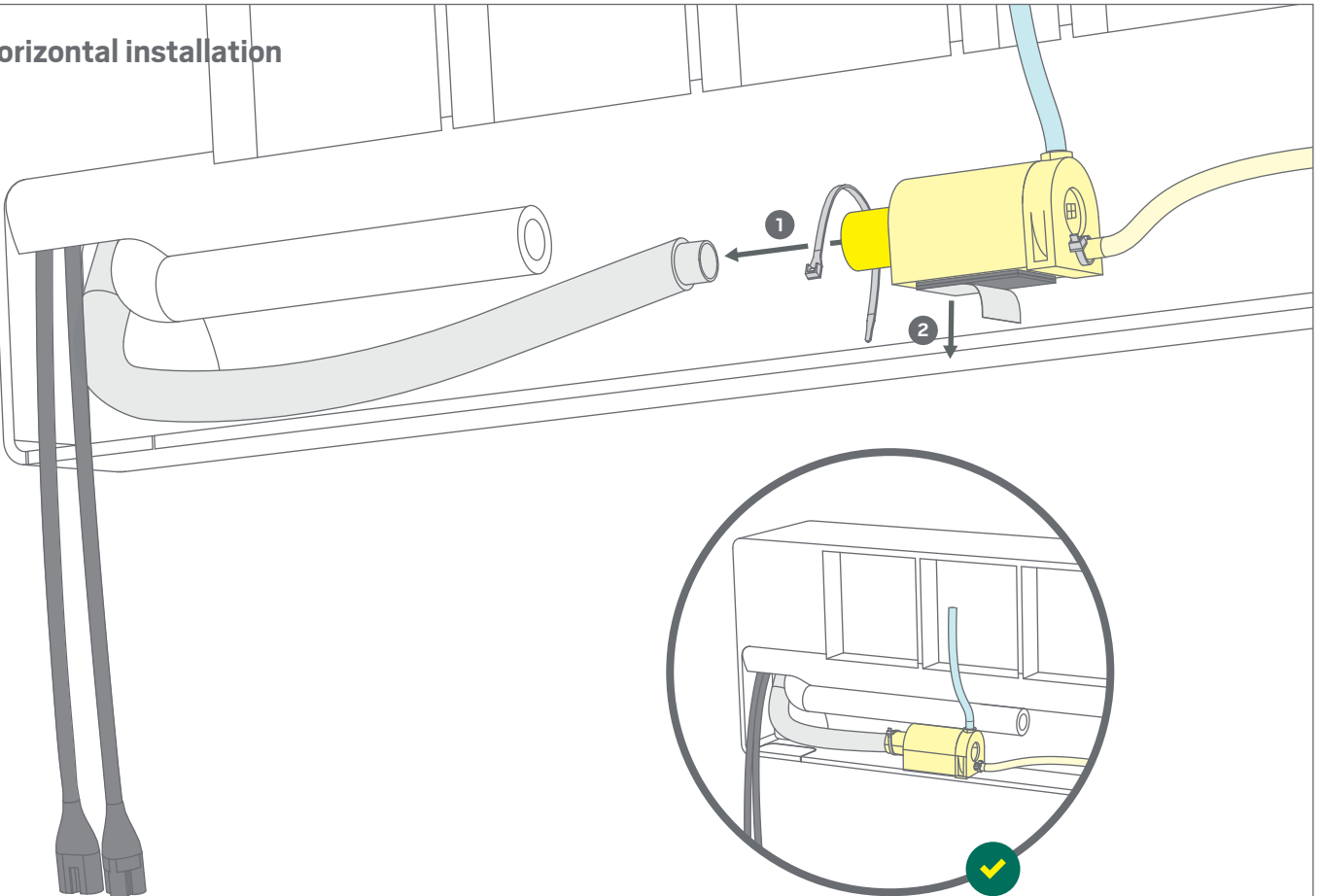

5b

Vertical installation

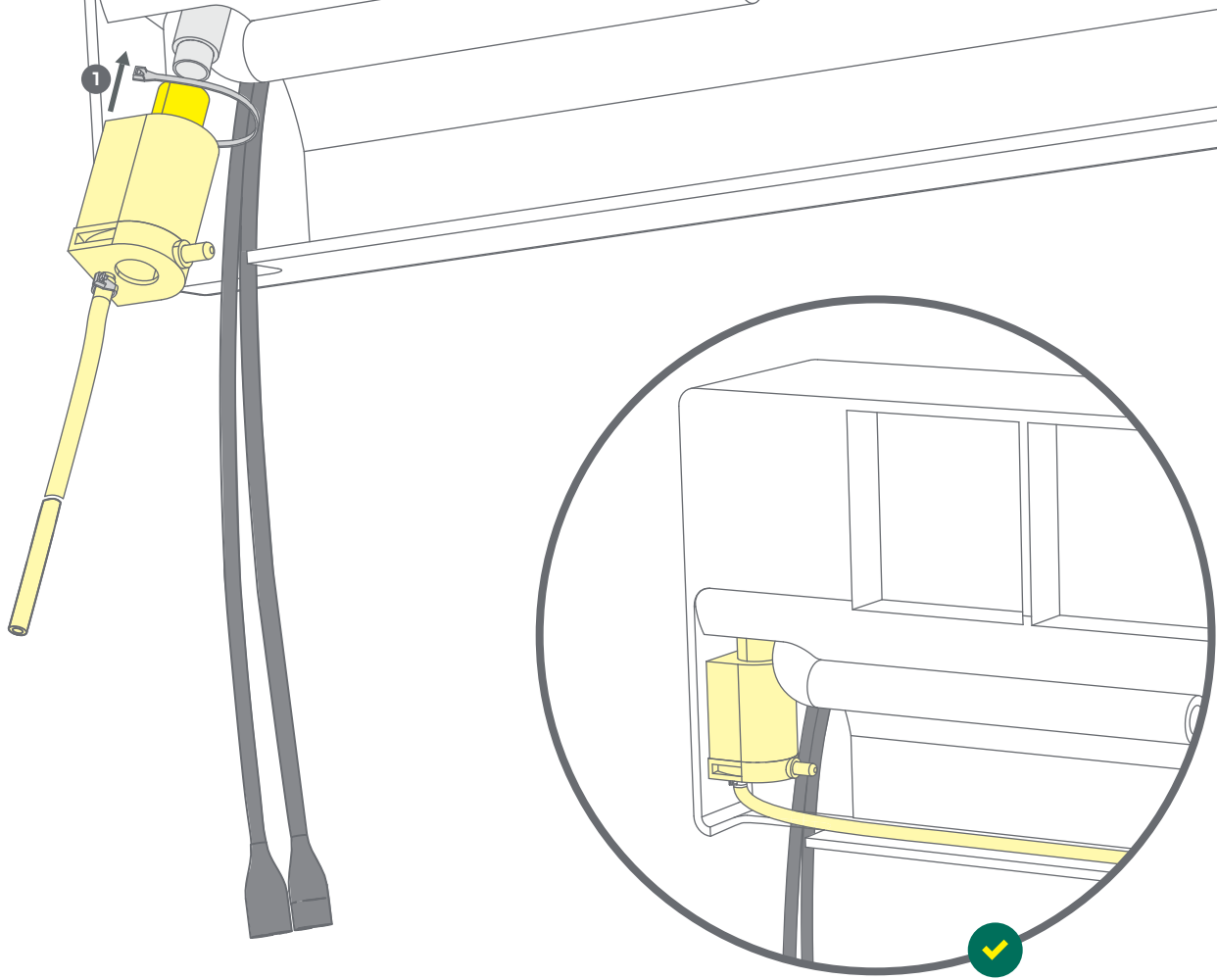

6

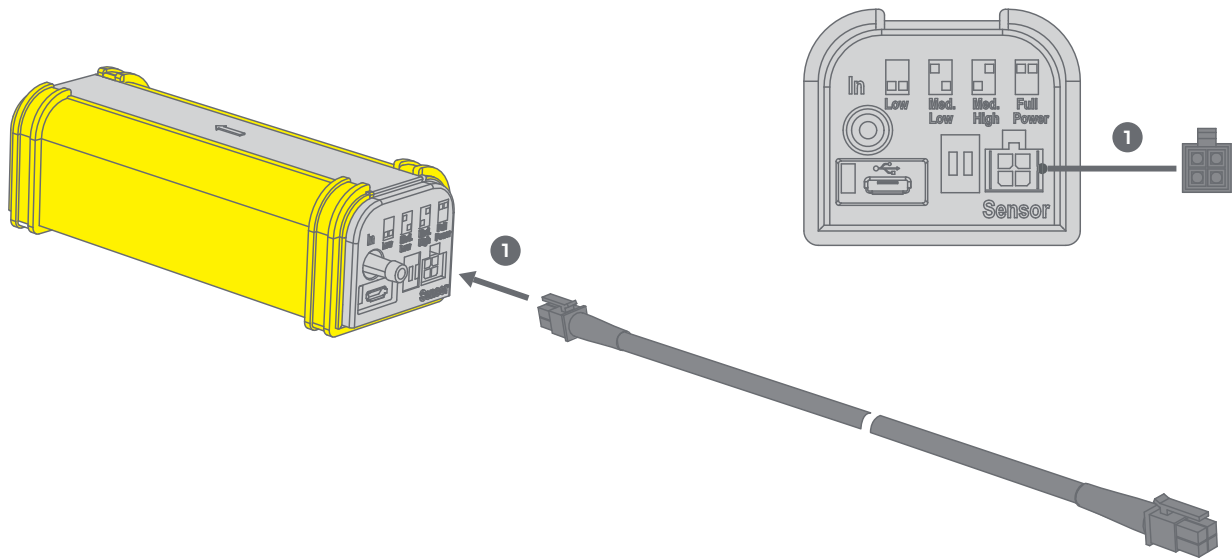

7

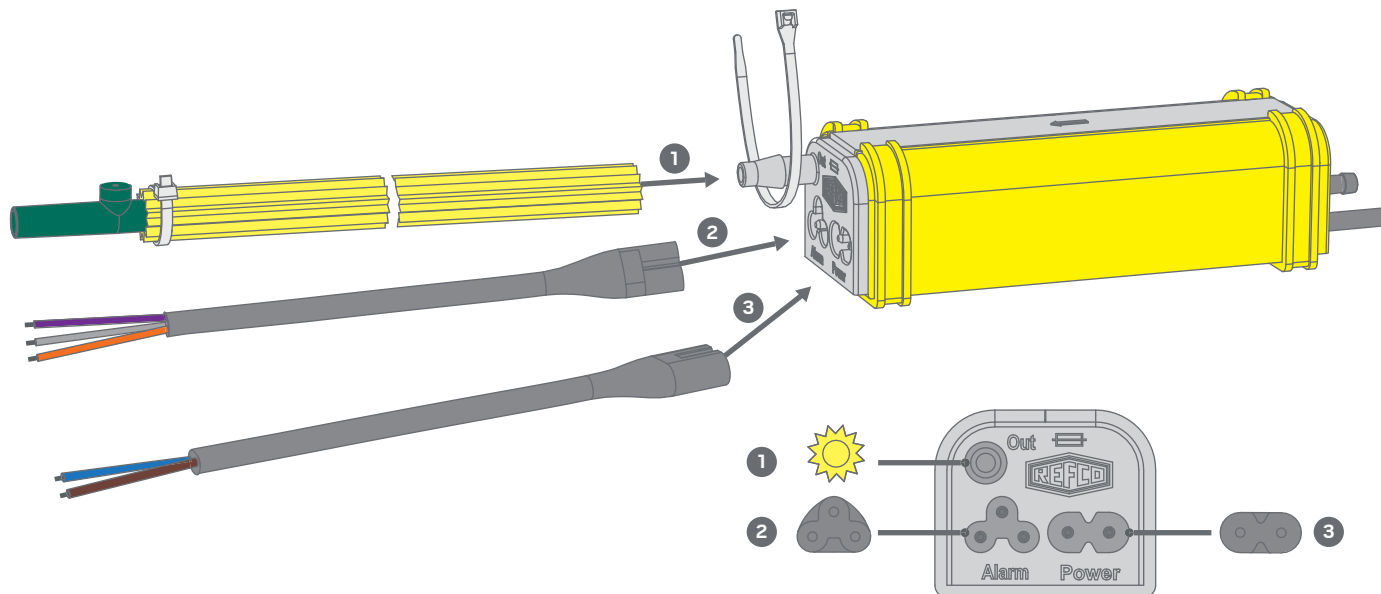

8a

Horizontal installation

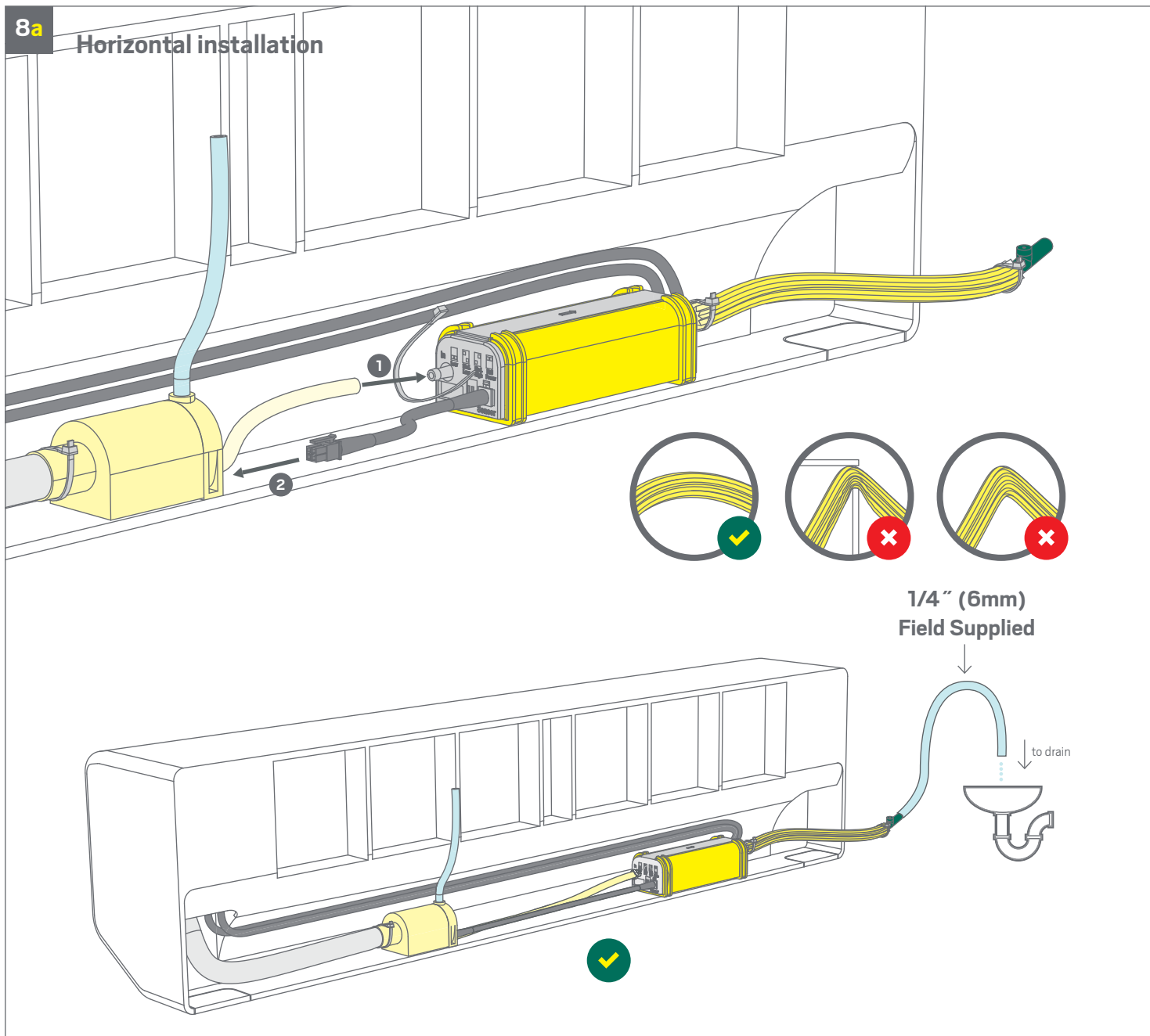



LED check

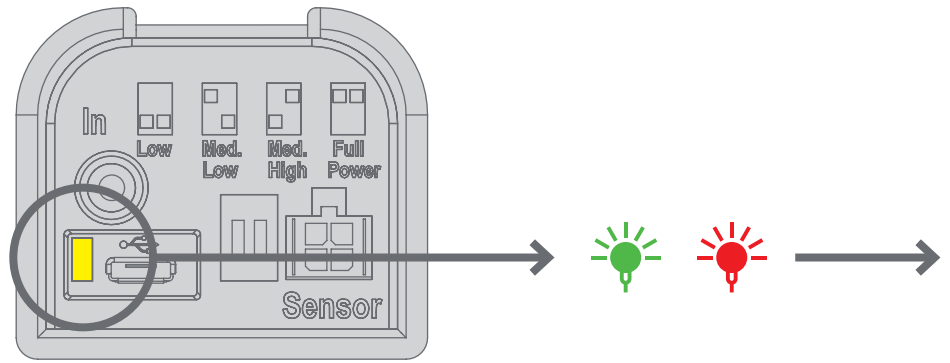

8b

Vertical installation

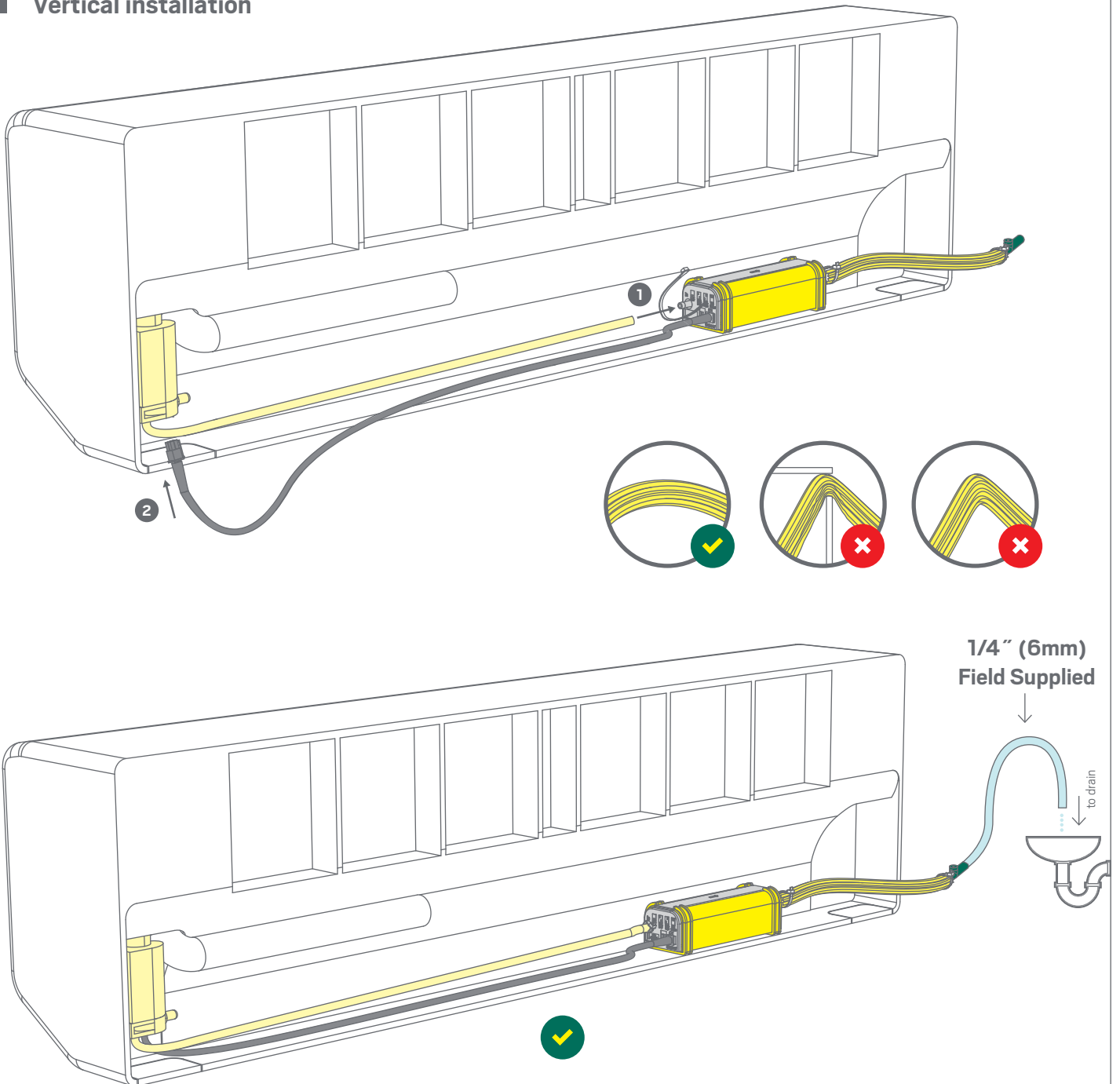

LED Check	No Power	○ (off)	○ (off)	○ (off)	○ (off)	○ (off)	Pump is miswired or no incoming voltage. Alarm fuse has been burned. Problem with A/C system or alarm is miswired.
	Power up LED sequence	●● 1 sec Red/Green	○ (off)	●● 1 sec Red/Green	○ (off)	●● 1 sec Red/Green	Alternating red/ green flashes 5x only then stop and go to standby (default relay operation).
	Standby waiting for water	● 1 sec Green	○ (off)	● 1 sec Green	○ (off)	● 1 sec Green	Blinking Green continuously.
	Pumping water	● Solid Green on	●	●	●	●	Running in low, med low, med high, or high power config. normal operation.
	High water level mode	● 1 sec Red	○ (off)	● 1 sec Red	○ (off)	● 1 sec Red	Running above high water level.
	Alarm relay activated	● Solid Red on	●	●	●	●	Pump cannot keep up with water input. Prevent flooding break power to A/C.
	Reconfigure code	●●●●● 3x red, 3x green	○ (off)	●●●●● 3x red, 3x green	○ (off)	●●●●● 3x red, 3x green	Pump has had 3 extra long run cycles, reconfigure for more power.

LED Check	Kein Strom	○ (aus)	○ (aus)	○ (aus)	○ (aus)	○ (aus)	Pumpe ist falsch angeschlossen oder es liegt keine Spannung am Stromversorgungseingang an. Alarmsicherung ist durchgebrannt. Problem mit dem A/C [Wechselstrom] System oder Alarm ist falsch angeschlossen.
	LED Einschalt-Sequenz	●● 1 Sek Rot / Grün	○ (off)	●● 1 Sek Rot / Grün	○ (aus)	●● 1 Sek Rot / Grün	Blinkt abwechselnd 5 x nur Rot / Grün, stoppt dann und geht in den Standby über (Standard Relais-Betrieb).
	Standby Auf Wasser warten	● 1 Sek Grün	○ (aus)	● 1 Sek Grün	○ (aus)	● 1 Sek Grün	Blinkt kontinuierlich grün.
	Wasser wird gepumpt	● Grün ständig an	●	●	●	●	Lauf in niedriger, mittlerer niedriger, mittlerer hoher oder hoher Leistungskonfiguration, normaler Betrieb.
	Hoher Wasserstand Modus	● 1 Sek Rot	○ (aus)	● 1 Sek Rot	○ (aus)	● 1 Sek Rot	Läuft über Hochwasser-Stand.
	Alarmrelais aktiviert	● Rot ständig an	●	●	●	●	Pumpe kann mit Wasserzufuhr nicht mithalten. Zur Vermeidung von Überschwemmungen / Überlauf die Stromversorgung abschalten.
	Code für Neukonfiguration	●●●●● 3x Rot, 3x Grün	○ (aus)	●●●●● 3x Rot, 3x Grün	○ (aus)	●●●●● 3x Rot, 3x Grün	Pumpe hatte 3 zusätzliche lange Laufzyklen, Neukonfiguration für mehr Leistung.

Voyants LED	Pas de courant	○ (éteint)	○ (éteint)	○ (éteint)	○ (éteint)	○ (éteint)	La pompe est mal câblée, ou aucune tension n'arrive. Le fusible d'alarme a grillé. Problème d'A/C ou alarme mal câblée.
	Séquence LED d'allumage	●● 1 sec Rouge/Vert	○ (éteint)	●● 1 sec Rouge/Vert	○ (éteint)	●● 1 sec Rouge/Vert	Clignotement alternatif rouge/ vert 5 fois, puis arrêt et passage en veille (fonctionnement relais par défaut).
	Veille en attente d'eau	● 1 sec Vert	○ (éteint)	● 1 sec Vert	○ (éteint)	● 1 sec Vert	Clignotement vert continu.
	Pompage de l'eau	● Vert allumé en fixe	●	●	●	●	Marche en configuration normale puissance basse, moyenne basse, moyenne haute ou haute.
	Mode niveau d'eau élevé	● 1 sec Rouge	○ (éteint)	● 1 sec Rouge	○ (éteint)	● 1 sec Rouge	Dépassement du niveau d'eau élevé.
	Relais d'alarme activé	● Rouge allumé en fixe	●	●	●	●	La pompe ne peut absorber l'eau entrante. Pour éviter l'inondation, coupure du courant de l'A/C.
	Code de reconfiguration	●●●●● 3 x rouge, 3 x vert	○ (éteint)	●●●●● 3 x rouge, 3 x vert	○ (éteint)	●●●●● 3 x rouge, 3 x vert	La pompe dispose de 3 cycles de fonctionnement très longs, reconfigurez pour plus de puissance.

Chequeo de los LEDs	Falta de energía de alimentación	○ (off)	○ (off)	○ (off)	○ (off)	○ (off)	La bomba no ha sido correctamente cableada o no tiene tensión de entrada. El fusible de alarma se ha fundido. Problema con el sistema A/C o la alarma no está correctamente cableado.
	Energía al cabo de la secuencia de luces LED	●● 1 segundo luz roja y verde	○ (off)	●● 1 segundo luz roja y verde	○ (off)	●● 1 segundo luz roja y verde	Las luces roja y verde se encienden alternadamente 5 veces, después de lo cual se activa el STOP y la bomba pasa al estado standby (el relé funciona por defecto).
	Standby del sistema esperando la presencia de agua	● 1 segundo luz verde	○ (off)	● 1 segundo luz verde	○ (off)	● 1 segundo luz verde	La luz verde parpadea de modo continuo.
	Agua bombeada	● luz verde permanente	●	●	●	●	Funcionamiento a potencia "baja", "media", "medio baja", "medio alta" o "alta". Configuración normal: potencia "alta".
	Modo "elevado nivel de agua"	● 1 segundo luz roja	○ (off)	● 1 segundo luz roja	○ (off)	● 1 segundo luz roja	Funcionamiento por encima del nivel de agua.
	El relé de alarma se ha activado	● luz roja permanente	●	●	●	●	La bomba no puede con el caudal de agua entrante. Prevenir inundación. Ajustar la potencia a A/C.
	Reconfigurar el correspondiente código	●●●●● 3 x luz roja / 3 x luz verde	○ (off)	●●●●● 3 x luz roja / 3 x luz verde	○ (off)	●●●●● 3 x luz roja / 3 x luz verde	La bomba ha ejecutado 3 ciclos de servicio extra prolongados. Reconfigurar para obtener más potencia.

Spie LED	Tutto spento	○ (off)	○ (off)	○ (off)	○ (off)	○ (off)	La pompa è cablata male o non vi è tensione in ingresso. Il fusibile dell'allarme è bruciato. Problema con il Sistema A/C Oppure l'allarme è cablato male.
	Sequenza LED di accensione	●● 1 sec Rosso/Verde	○ (off)	●● 1 sec Rosso/Verde	○ (off)	●● 1 sec Rosso/Verde	Rosso/Verde in alternanza lampeggia solo 5x quindi si ferma e va in standby (mancanza funzionamento relè).
	Standby in attesa di acqua	● 1 sec Verde	○ (off)	● 1 sec Verde	○ (off)	● 1 sec Verde	Verde lampeggiante in continuo.
	Pompeggio acqua	● Verde fisso on	●	●	●	●	Funzionante in basso, med basso, med alto, o config alta potenza funzionamento normale.
	Modalità alto livello acqua	● 1 sec Rosso	○ (off)	● 1 sec Rosso	○ (off)	● 1 sec Rosso	Funzionante al di sopra livello alto acqua.
	Relè di allarme attivo	● Rosso fisso acceso	●	●	●	●	La pompa non può far fronte all'ingresso di acqua. Per prevenire allagamento si interrompe alimentazione ad A/C.
	Codice riconfigurazione	●●●●● 3x rosso, 3x verde	○ (off)	●●●●● 3x rosso, 3x verde	○ (off)	●●●●● 3x rosso, 3x verde	La pompa ha avuto 3 cicli di funzionamento eccessivamente lunghi, riconfigurazione per maggiore potenza.

LED 检查	无通电	○ (灭)	○ (灭)	○ (灭)	○ (灭)	○ (灭)	泵接线错误或无进入电压。报警保险丝已烧毁。空调系统故障 或报警接线错误。
	通电 LED 序列	●● 1 秒红/绿	○ (灭)	●● 1 秒红/绿	○ (灭)	●● 1 秒红/绿	交替红/绿闪烁 5 次, 然后停止并进入待机状态 (默认继电器操作)。
	待机等待水	● 1 秒绿	○ (灭)	● 1 秒绿	○ (灭)	● 1 秒绿	持续闪烁绿灯。
	泵水	● 持续亮绿灯	●	●	●	●	以低、中低、中高或高功率配置正常操作运行。
	高水位模式	● 1 秒红	○ (灭)	● 1 秒红	○ (灭)	● 1 秒红	在高水位以上运行。
	报警继电器激活	● 持续亮红灯	●	●	●	●	泵跟不上水输入速度。防止溢流, 断开空调电源。
	重新配置代码	●●●●● 3x 红, 3x 绿	○ (灭)	●●●●● 3x 红, 3x 绿	○ (灭)	●●●●● 3x 红, 3x 绿	泵经过 3 次超长运行循环, 重新配置以获得更大功率。



Change fuse

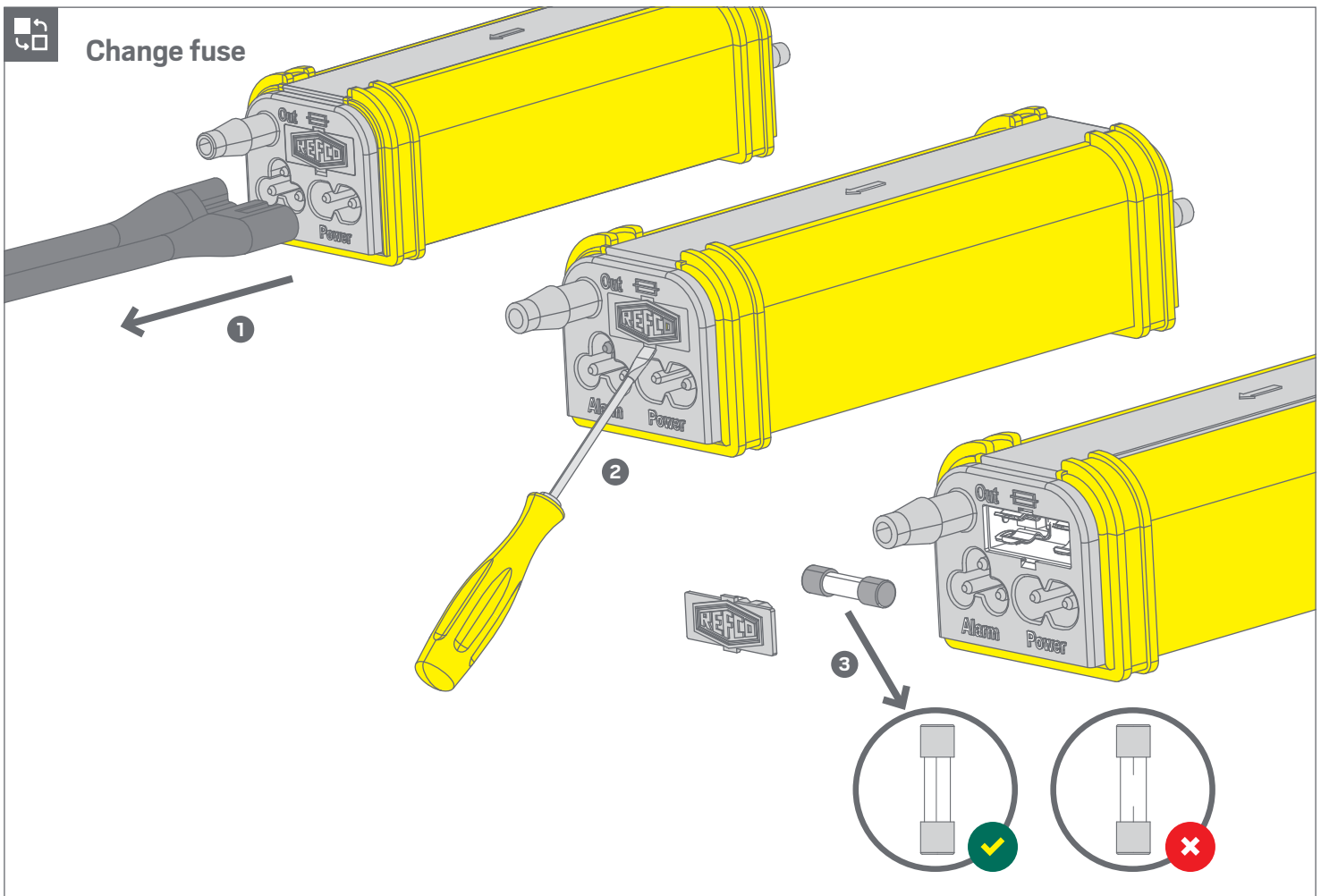

Corrected Flow Based on Installation L/Hr. 1/4" (6mm) discharge tube @ full power

A	B	C				
		Total Length (Run) Meters				
Suction (lift)	Discharge (Rise) Meters	5	10	15	20	30
0.0 m	0	42	42	40	40	40
	1 (3.3ft.)	42	42	40	40	36
	3 (9.9 ft.)	37	37	35	35	34
	5 (16.4 ft.)	31	30	29	29	29
	10 (32.8 ft.)	17	16	15	14	14
	15 (49.2 ft.)	9	9	9	9	8
1.0 m (3.3 Ft)	0	42	42	42	40	40
	1 (3.3ft.)	42	42	42	40	39
	3 (9.9 ft.)	36	36	35	35	34
	5 (16.4 ft.)	30	30	29	29	29
	10 (32.8 ft.)	16	16	16	16	15
	15 (49.2 ft.)	10	10	10	10	10
2.0 m (6.6 Ft.)	0	35	35	35	35	34
	1 (3.3ft.)	33	33	33	32	31
	3 (9.9 ft.)	33	32	31	31	30
	5 (16.4 ft.)	27	26	26	26	25
	10 (32.8 ft.)	17	17	16	16	15
	15 (49.2 ft.)	10	10	10	9	9
3.0 m (9.9 Ft.)	0	30	30	30	30	29
	1 (3.3ft.)	28	28	28	28	27
	3 (9.9 ft.)	28	28	28	27	26
	5 (16.4 ft.)	23	23	23	23	22
	10 (32.8 ft.)	15	15	15	15	15
	15 (49.2 ft.)	7	7	6	5	5

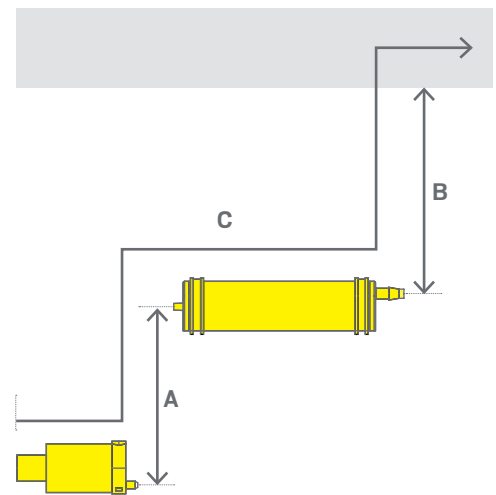

Conversion formula for US Gallons/Hr:

$$\text{L/Hr.} \times 0.264 = \text{G/Hr.}$$

REFCO®

REFCO is a registered trademark in various countries. Patent Pending.
 © Copyright 2016 by REFCO Manufacturing Ltd. Switzerland – all rights reserved.
 More information: visit www.refco.ch