

Cembrit Multi Force

Datasheet

Cembrit Multi Force functional board is the ideal solution in cases where lightweight walls and ceilings have to be able to withstand exceptionally hard use and protect in case of fire. Cembrit Multi Force functional boards are made of cement and limestone filler, reinforced with a specially selected fibre material. They have a special surface that is particularly resistant to moisture, impact and other kinds of heavy-duty use.

This surface is easy to paint, or to treat with other kinds of finish. It also makes these boards easy to clean. In addition, Cembrit Multi Force functional boards are sound absorbent and non-combustible, and also resistant to both rot and mould. Their exceptional durability results in an extremely long service life. Cembrit Multi Force is a high quality multi-purpose fibercement board for demanding use.

Standard sizes

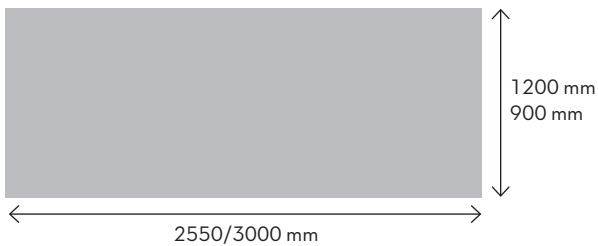

Project sales



Long edges

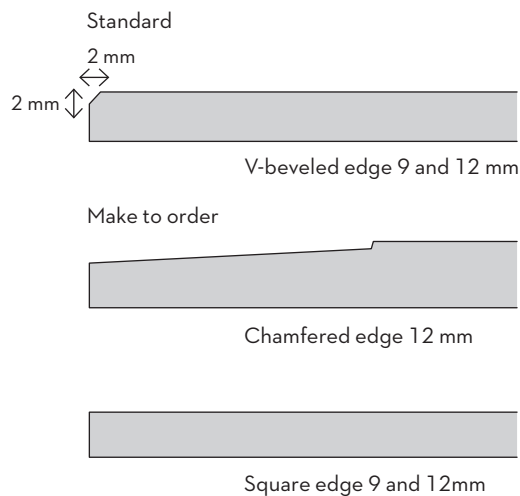

Cembrit Multi Force

Dimension (nominal)			
Thickness	mm	9.0	12.0
Tolerances (EN 12467, Level 1)			
Thickness	mm	± 0.9	± 1.2
Width	mm	± 3	± 3
Length	mm	± 5	± 5
Physical properties			
Density, dry, minimum (EN 12467)	Kg/m ³	1000	1000
Density, dry, average (EN 12467)	Kg/m ³	1150	1150
Weight (Average incl. 5% moisture)	Kg/m ²	10.9	14.5
Moisture content (on dispatch ex works, ASTM C1185)	%	3-6	3-6
Mechanical properties (EN 12467)			
Bending modulus of elasticity			
Dry E-module with grain	GPa	4	4
Dry E-module across grain	GPa	3	3
Wet E-module with grain	GPa	3	3
Wet E-module across grain	GPa	2	2
Bending strength (EN 12467)			
Dry with grain	MPa	10	10
Dry across grain	MPa	8	8
Wet with grain	MPa	5	5
Wet across grain	MPa	4	4
Tensile strength (30-50% RH)			
With grain	MPa	5	5
Across grain	MPa	4	4
Interlaminar bond			
Dry	MPa	Min. 0.3	Min. 0.3
Impact strength (Charpy)			
Dry with grain	kJ/m ²	1.5	1.5
Dry across grain	kJ/m ²	1.2	1.2
Thermal properties			
Coefficient of thermal expansion	mm/m °C	0.007	0.007
Specific heat	kJ/kg °C	0.9	0.9
Temperature range	°C	Max. 150	Max. 150
Thermal conductivity (ISO 8301, EN 12667)	λ ₁₀ W/(mK) λ ₃₀ W/(mK)	0.23	-

Cembrit Multi Force

Hygrothermal properties			
Water absorption (24 hrs 105°C, 24 hrs in water, EN 12467)	%	32.0	32.0
Moisture movement (wet-dry-wet)	mm/m	2.2	2.2
Water vapour transmission properties (EN 12572-C)			
Vapour transmission resistance (Z-value)	Gpa * m ² * s/kg	1.44	1.96
Vapour transmission resistance	s/m	10549	14356
Vapour diffusion equivalent air layer thickness	Sd (m)	0.28	0.38
Vapour resistivity	MNs/g * m	157	162
Vapour resistance factor	μ	30.5	31.4
Vapour resistance	MNs/g	1.4	2.0
Vapour transmission	USPerm	12.2	9
Fire properties			
Reaction to fire (EN 13501-1)	EN 13501	A1	A1
Fire protection classification (EN 13501-2)		K ₁ 10 & K ₂ 10	K ₁ 10, K ₂ 10, K ₂ 30*
Fire performance (ASTM E136)		Pass	Pass
Other properties			
pH surface		11	11
Category, Class (EN 12467)		NT C21	NT C21

Soft- and hard body impact resistance (ETAG 034, ISO 7892), 9 mm

Type of impact	Energy	Category IV	Category III	Category II	Category I
Hard body	1 Joule	passed	-	-	-
	3 Joule	-	passed	passed	passed
	10 Joule	-	-	passed	passed
Soft body	10 Joule	passed	passed	-	-
	60 Joule	-	-	not passed	not passed
	300 Joule	-	-	not passed	-
	400 Joule	-	-	-	not passed

Soft- and hard body impact resistance (ETAG 034, ISO 7892), 12 mm

Type of impact	Energy	Category IV	Category III	Category II	Category I
Hard body	1 Joule	passed	-	-	-
	3 Joule	-	passed	passed	passed
	10 Joule	-	-	passed	passed
Soft body	10 Joule	passed	passed	-	-
	60 Joule	-	-	not passed	not passed
	300 Joule	-	-	not passed	-
	400 Joule	-	-	-	not passed

* Two layer, 12mm Multi Force fixed directly to the substrate + 9mm Windstopper Extreme facing the fire exposure

www.cembrit.com

Please visit the local website for contact details and further information.

Cembrit Multi Force

Soft- and hard body impact resistance (ETAG 034, ISO 7892), double layer 9 mm

Type of impact	Energy	Category IV	Category III	Category II	Category I
Hard body	1 Joule	passed	-	-	-
	3 Joule	-	passed	passed	passed
	10 Joule	-	-	passed	passed
Soft body	10 Joule	passed	passed	-	-
	60 Joule	-	-	not passed	not passed
	300 Joule	-	-	not passed	-
	400 Joule	-	-	-	not passed

Soft- and hard body impact resistance (ETAG 034, ISO 7892), double layer 12 mm

Type of impact	Energy	Category IV	Category III	Category II	Category I
Hard body	1 Joule	passed	-	-	-
	3 Joule	-	passed	passed	passed
	10 Joule	-	-	passed	passed
Soft body	10 Joule	passed	passed	-	-
	60 Joule	-	-	passed	passed
	300 Joule	-	-	passed	-
	400 Joule	-	-	-	not passed