

Compac flange kits

To increase the flexibility for units with standard threaded connections, SWEP offer a range of Compac flange kits. The threaded part is easily assembled to the connections and the counter flange welded to your pipe.

SWEP accessories meet the same high standards as the company's BPHEs. They are produced according to SWEP's specification by rigorously selected suppliers. The high-quality materials are carefully chosen for compatibility, while the accurate dimensions save you time and money on installation. With SWEP accessories you have the assurance that everything will fit and perform the way the design engineers intended.

Standard connections

SWEP screw-on flanges are used to convert our ISO-G connections to weld neck DN Compac flanges. This package is equipped with bolts, washers and nuts.

For more information, please contact your local SWEP representative.



Technical data *	
Max working temperature	200°C
Min working temperature	-15°C
Max working pressure	40 bar

Material options	
Stainless steel	1.4404 alt 1.4571
Carbon steel	C22.8

* According properties of SWEP gasket

Size	A (mm)	B (mm)	C	D (mm)	E	F (mm)	G (mm)	N
2"	12	37	DN50	39,0	G 2"	91	112	8
2 1/2"	12	37	DN65	60,0	G 2 1/2"	106	125	8

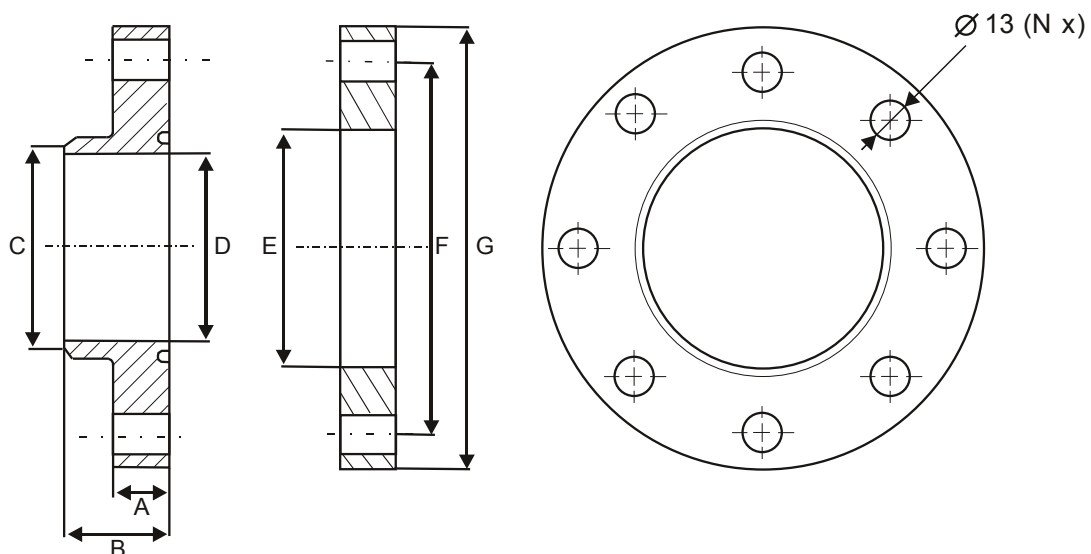

www.swep.net