

Approval body for construction products  
and types of construction

Bautechnisches Prüfamt

An institution established by the Federal and  
Laender Governments



## European Technical Assessment

**ETA-13/1068**  
**of 28 February 2014**

### General Part

Technical Assessment Body issuing the  
European Technical Assessment:

Deutsches Institut für Bautechnik

Trade name of the construction product

SPIT B-LONG

Product family  
to which the construction product belongs

Plastic anchor for multiple use in concrete and masonry  
for non-structural applications

Manufacturer

ITW Construction Products Italy S.r.l.  
V.le Regione Veneto, 5  
35127 PADOVA (PD)  
ITALIEN

Manufacturing plant

ITW Construction Products Italy S.r.l.  
V.le Regione Veneto, 5  
35127 PADOVA (PD)  
ITALIEN

This European Technical Assessment  
contains

18 pages including 14 annexes which form an integral part  
of this assessment

This European Technical Assessment is  
issued in accordance with Regulation (EU)  
No 305/2011, on the basis of

Guideline for European technical approval of "plastic  
anchors for multiple use in concrete and masonry for  
non-structural applications", ETAG 020, Edition  
March 2012  
used as European Assessment Document (EAD)  
according to Article 66 Paragraph 3 of Regulation (EU)  
No 305/2011.

The European Technical Assessment is issued by the Technical Assessment Body in its official language. Translations of this European Technical Assessment in other languages shall fully correspond to the original issued document and shall be identified as such.

Communication of this European Technical Assessment, including transmission by electronic means, shall be in full. However, partial reproduction may only be made with the written consent of the issuing Technical Assessment Body. Any partial reproduction has to be identified as such.

This European Technical Assessment may be withdrawn by the issuing Technical Assessment Body, in particular pursuant to information by the Commission according to Article 25 Paragraph 3 of Regulation (EU) No 305/2011.

## Specific part

### 1 Technical description of the product

The frame anchor SPIT B-LONG is a plastic anchor consisting of a plastic sleeve made of polyamide and an accompanying specific screw of galvanised steel or of stainless steel.

The plastic sleeve is expanded by screwing in the specific screw which presses the sleeve against the wall of the drilled hole.

The Illustration and the description of the product are given in Annex A.

### 2 Specification of the intended use in accordance with the applicable European Assessment Document

The performances given in Section 3 are only valid if the anchor is used in compliance with the specifications and conditions given in Annex B.

The verifications and assessment methods on which this European Technical Assessment is based lead to the assumption of a working life of the anchor of 50 years. The indications given on the working life cannot be interpreted as a guarantee given by the producer, but are to be regarded only as a means for choosing the right products in relation to the expected economically reasonable working life of the works.

### 3 Performance of the product and references to the methods used for its assessment

#### 3.1 Mechanical resistance and stability (BWR 1)

Requirements with respect to the mechanical resistance and stability of non load bearing parts of the works are not included in this Basic requirement but are under the Basic Requirement safety in use.

#### 3.2 Safety in case of fire (BWR 2)

Essential characteristic	Performance
Reaction to fire	Anchorage satisfy requirements for Class A1
Resistance to fire	No performance determined (NPD)

#### 3.3 Hygiene, health and the environment (BWR 3)

Not relevant.

#### 3.4 Safety in use (BWR 4)

Essential characteristic	Performance
Characteristic resistance for tension and shear loads	See Annex C 1 - C 6
Characteristic resistance for bending moments	See Annex C 1
Displacements under shear and tension loads	See Annex C 1, C 6
Edge distances and spacings	See Annex B 3, B 4

**3.5 Protection against noise (BWR 5)**

Not relevant.

**3.6 Energy economy and heat retention (BWR 6)**

Not relevant.

**3.7 Sustainable use of natural resources (BWR 7)**

For the sustainable use of natural resources no performance was investigated for this product.

**3.8 General aspects**

The verification of durability is part of testing of the essential characteristics. Durability is only ensured if the specifications of intended use according to Annex B are kept.

**4 Assessment and verification of constancy of performance (AVCP) system applied, with reference to its legal base**

According to Decision of the Commission of 27 June 1997 (97/463/EC) (Official Journal of the European Communities L 198 of 25.07.1997, p. 31-32) the system of assessment and verification of constancy of performance (see Annex V and Article 65 Paragraph 2 to Regulation (EU) No 305/2011) given in the following table applies.

Product	Intended use(s)	Level or class	System
Plastic anchors for use in concrete and masonry	For use in systems, such as façade systems, for fixing or supporting elements which contribute to the stability of the systems	-	2+

**5 Technical details necessary for the implementation of the AVCP system, as provided in the applicable European Assessment Document**

Technical details necessary for the implementation of the AVCP system are laid down in the control plan deposited at Deutsches Institut für Bautechnik.

Issued in Berlin on 28 February 2014 by Deutsches Institut für Bautechnik

Dr.-Ing. Karsten Kathage  
Vice-President

*beglaubigt:*  
E. Aksünger

CONCRETE

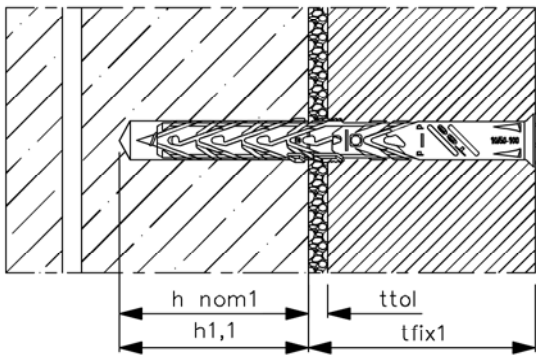

CONCRETE

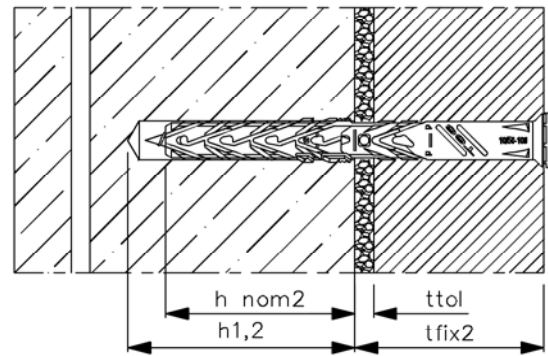

HOLLOW

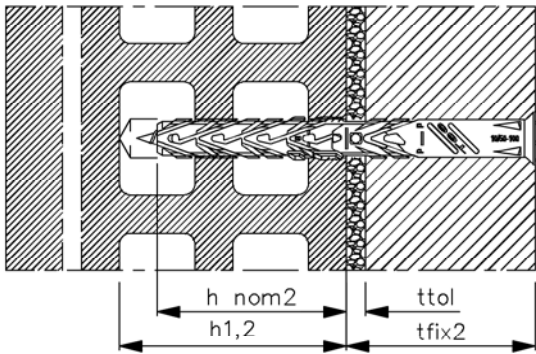

HOLLOW

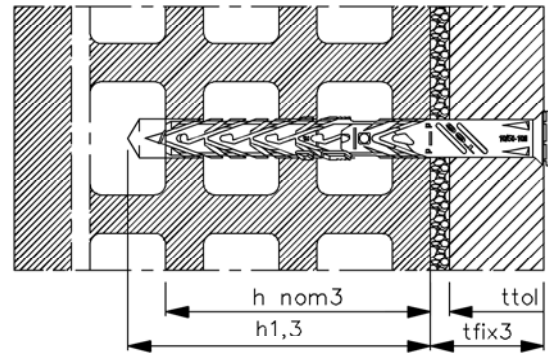

AAC

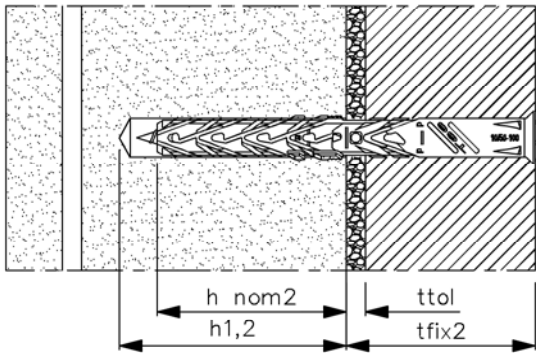

AAC

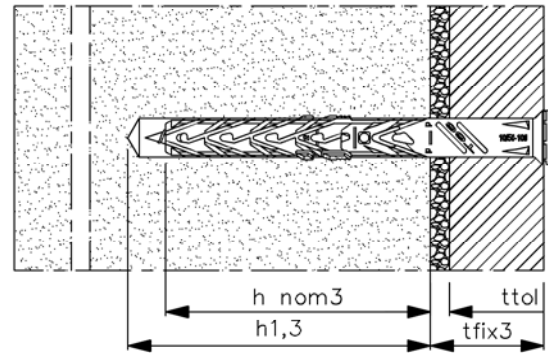

Legend:  $h_{nom,1}$ ,  $h_{nom,2}$ ,  $h_{nom,3}$  = overall plastic anchor embedment depth in the base material  
 $h_{1,1}$ ,  $h_{1,2}$ ,  $h_{1,3}$  = depth of drilled hole to deepest point  
 $t_{fix1}$ ,  $t_{fix2}$ ,  $t_{fix3}$  =  $t_{tol}$  + thickness of fixture  
 $t_{tol}$  = thickness of equalizing layer or non-load bearing coating

SPIT B-LONG

**Product description**  
Installed condition

Annex A 1

### B-LONG D8

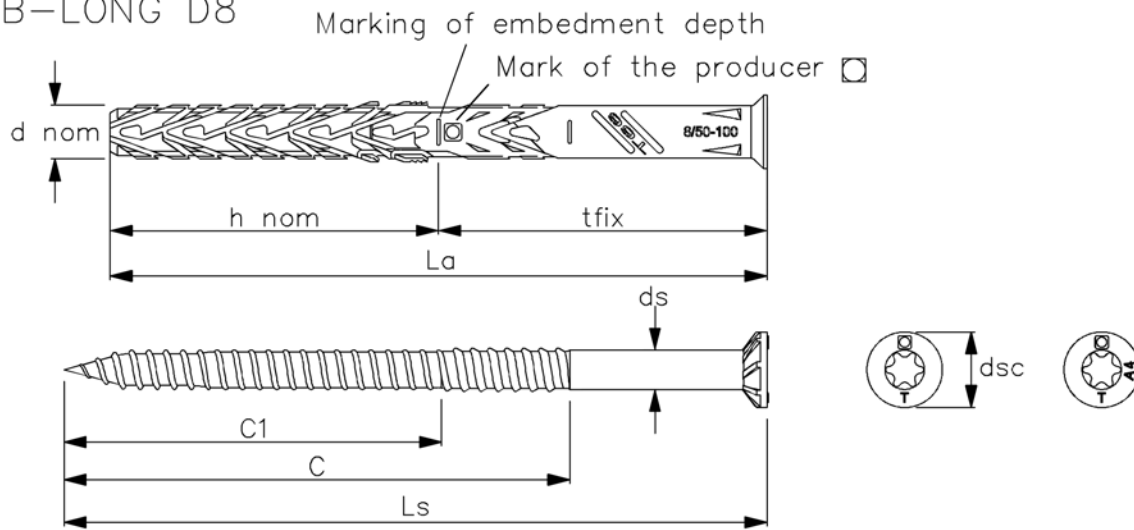

### B-LONG D10

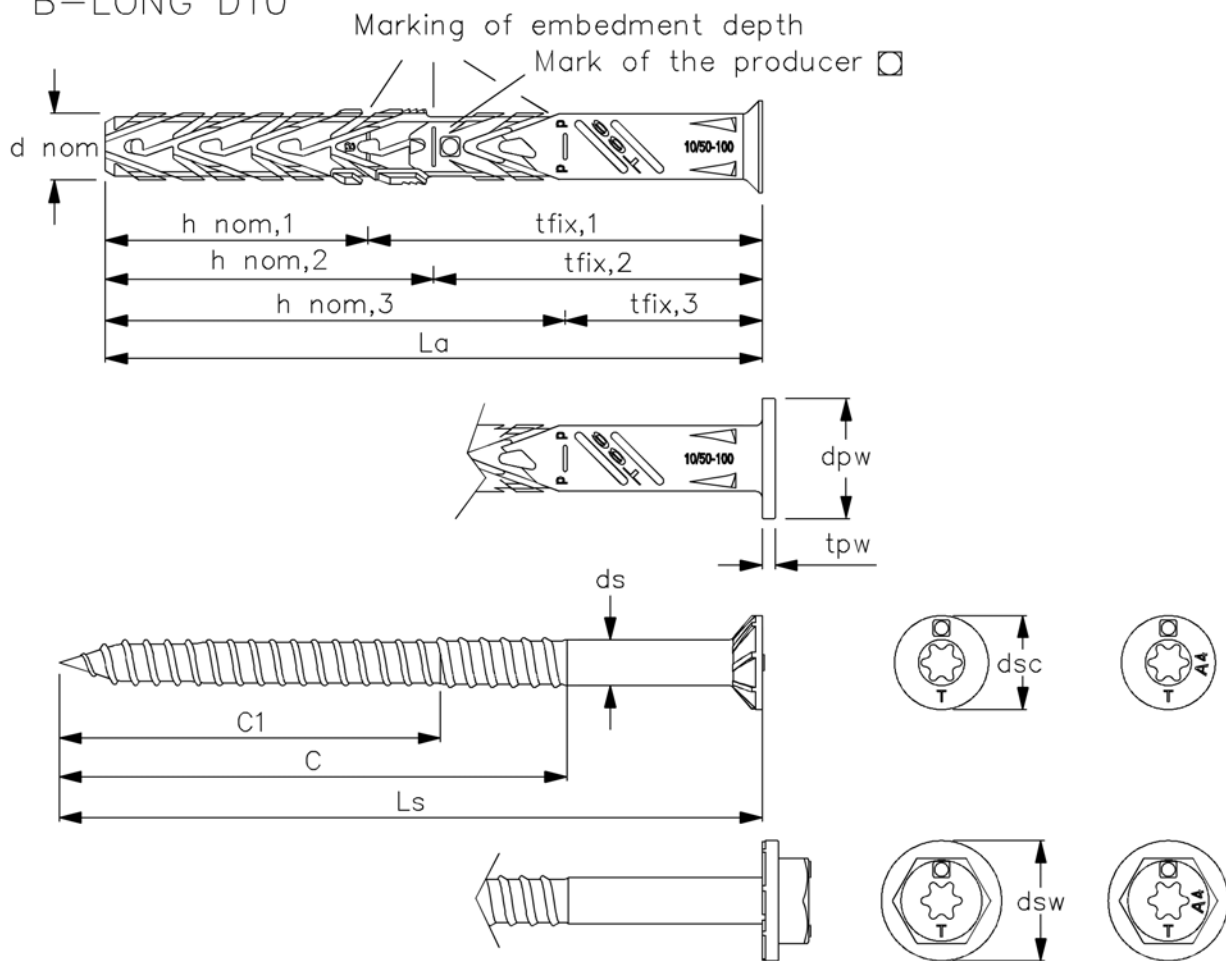

SPIT B-LONG

**Product description**  
Anchor types and specific screw

Annex A 2

Table A1: Dimensions [mm]

Anchor Type	Anchor sleeve						Special screw			
	$d_{nom}$	$h_{nom,1}$	$h_{nom,2}$	$h_{nom,3}$	min $L_a$	max $L_a$	$d_s$	$c_1$	$c$	$L_s$
B-LONG 8	8	-	50	-	60	150	6	57	77 <sup>1)</sup>	67-157
B-LONG 10	10	40	50	70	60	300	7	57	77 <sup>1)</sup>	67-307

<sup>1)</sup> not valid for  $L_s = 67$  mm

Table A2: Materials

Designation	Material
Anchor sleeve	polyamide, colour grey
Special screw	steel, zinc coated (electro galvanized) $\geq 5 \mu\text{m}$ according EN ISO 4042: 2001-01 $f_{yk} \geq 480\text{N/mm}^2$ ; $f_{uk} \geq 600\text{N/mm}^2$
	stainless steel, material number 1.4401 / 1.4404 / 1.4571 / 1.4578 (A4 according to ISO 3506 - 01: 2010-04) $f_{yk} \geq 600\text{N/mm}^2$ ; $f_{uk} \geq 800\text{N/mm}^2$

SPIT B-LONG

**Product description**  
Dimensions and materials

Annex A 3

### Specifications of intended use

#### Anchorage subject to:

- Static and quasi-static loads
- Multiple fixing of non-structural applications

#### Base materials:

- Reinforced or unreinforced normal weight concrete with strength classes  $\geq$  C12/15 (use category a), according to EN 206-1:2000.
- Solid brick masonry (use category b), according to Annex C 2.  
Note: The characteristic resistance is also valid for larger brick sizes and larger compressive strength of the masonry unit.
- Hollow brick masonry (use category c), according to Annex B 2, C 3, C 4 and C 5.
- Autoclaved aerated concrete (use category d), according to Annex C 6.
- Mortar strength class of the masonry M2.5 at minimum according to EN 998-2:2010.
- For other base materials of the use categories a, b, c and d (only B-LONG Ø10) the characteristic resistance of the anchor may be determined by job site tests according to ETAG 020 Edition March 2012, Annex B.

#### Temperature Range:

- c:  $-40^{\circ}\text{C}$  to  $+50^{\circ}\text{C}$  (max. short term temperature  $+50^{\circ}\text{C}$  and max. long term temperature  $+30^{\circ}\text{C}$ )
- b:  $-40^{\circ}\text{C}$  to  $+80^{\circ}\text{C}$  (max. short term temperature  $+80^{\circ}\text{C}$  and max. long term temperature  $+50^{\circ}\text{C}$ )

#### Use conditions (Environmental conditions):

- Structures subject to dry internal conditions (zinc coated steel, stainless steel).
- Structures subject to external atmospheric exposure including industrial and marine environment (stainless steel).
- Structures subject to permanently damp internal condition, if no particular aggressive conditions exist (stainless steel).

Note: Particular aggressive conditions are e.g. permanent, alternating immersion in seawater or the splash zone of seawater, chloride atmosphere of indoor swimming pools or atmosphere with extreme chemical pollution (e.g. in desulphurization plants or road tunnels where de-icing materials are used).

#### Design:

- The anchorages are designed in accordance with the ETAG 020 Edition March 2012, Annex C under the responsibility of an engineer experienced in anchorages and masonry work.
- Verifiable calculation notes and drawings shall be prepared taking account of the loads to be anchored, the nature and strength of the base materials and the dimensions of the anchorage members as well as of the relevant tolerances. The position of the anchor is indicated on the design drawings.
- Fasteners are only to be used for multiple fixings for non-structural application, according to ETAG 020 Edition March 2012.

#### Installation:

- Hole drilling by the drill modes given in Annexes C1 to C8 for use categories b, c and d; the influence of other drilling methods may be determined by job side tests according to ETAG 020 Edition March 2012, Annex B.
- Anchor installation carried out by appropriately qualified personnel and under the supervision of the person responsible for technical matters of the site.
- Installation temperature from  $-5^{\circ}\text{C}$  to  $+40^{\circ}\text{C}$ .
- Exposure to UV due to solar radiation of the anchor not protected  $\leq$  6 weeks.

SPIT B-LONG	
<b>Intended use</b> Specifications	Annex B 1



Table B1: Geometry and dimensions of hollow or perforated brick

<p>Figure 1</p>	<p>Figure 2</p>
<p>Figure 3</p>	<p>Figure 4</p>
<p>Figure 5</p>	

SPIT B-LONG

**Intended use**  
Geometry and dimensions of hollow or perforated brick

Annex B 2

Table B2: Installation parameters

Anchor type				B-LONG 8	B-LONG 10		
				a,b,c	a	b	c <sup>1),d</sup>
Use category				a,b,c	a	b	c <sup>1),d</sup>
Drilling hole diameter	$d_0$	[mm]	=	8	10		
Cutting diameter of drill bit	$d_{cut}$	[mm]	≤	8,45	10,45		
Depth of drilled hole to deepest point $h_{1,1}$	$h_{1,1}$	[mm]	≥	-	50	-	-
Overall plastic anchor embedment depth in the base material $h_{nom,1}$	$h_{nom,1}$	[mm]	≥	-	40	-	-
Depth of drilled hole to deepest point $h_{1,2}$	$h_{1,2}$	[mm]	≥	60	60	60	60
Overall plastic anchor embedment depth in the base material $h_{nom,2}$	$h_{nom,2}$	[mm]	≥	50	50	50	50
Depth of drilled hole to deepest point $h_{1,3}$	$h_{1,3}$	[mm]	≥	-	-	-	80
Overall plastic anchor embedment depth in the base material $h_{nom,3}$	$h_{nom,3}$	[mm]	≥	-	-	-	70
Diameter of the clearance hole in the fixture	$d_f$	[mm]	≤	8,5	10,5		

<sup>1)</sup> For hollow or perforated masonry the influence of  $h_{nom} > 50$  mm has to be detected by job side tests according to ETAG 020 Edition March 2012, Annex B

Table B3: Minimum thickness of member, edge distance and spacing in concrete

Anchor type		Minimum thickness of member	Characteristic edge distance	Minimum allowable spacing and edge distances
		$h_{min}$ [mm]	$c_{cr,N}$ [mm]	[mm]
B-LONG 8 ( $h_{nom}=50$ )	concrete ≥ C16/20	100	50	$s_{min} = 50$ for $c_{min} = 50$
	concrete C12/15		70	$s_{min} = 70$ for $c_{min} = 70$
B-LONG 10 ( $h_{nom}=40$ )	concrete ≥ C16/20		80	$s_{min} = 60$ for $c_{min} = 50$
	concrete C12/15		110	$s_{min} = 85$ for $c_{min} = 70$
B-LONG 10 ( $h_{nom}=50$ )	concrete ≥ C16/20		100	$s_{min} = 70$ for $c_{min} = 60$
	concrete C12/15		140	$s_{min} = 100$ for $c_{min} = 85$

Scheme of distances and spacings in concrete

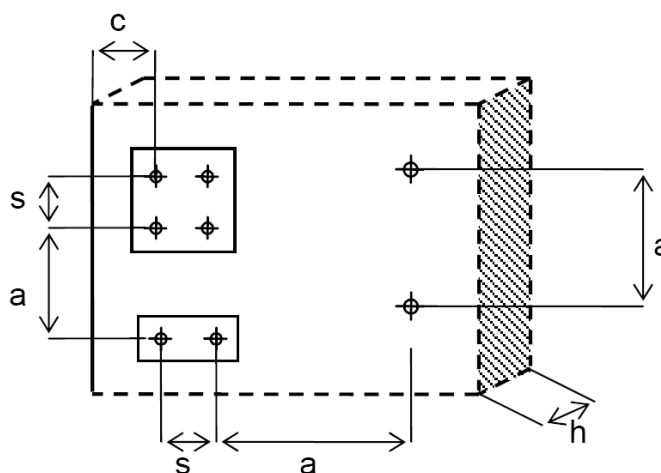

SPIT B-LONG

**Intended use**

Installation parameters, edge distances and spacings for use in concrete

Annex B 3

Table B4: Minimum distances and dimensions in masonry

Anchor type		B-LONG 8	B-LONG 10
Minimum thickness of member	$h_{min}$ [mm]	110	110
Single anchor			
Minimum allowable spacing	$a_{min}$ [mm]	250	250
Minimum allowable edge distance	$c_{min}$ [mm]	100	100
Anchor group			
Minimum allowable spacing perpendicular to free edge	$s_{1,min}$ [mm]	200	200
Minimum allowable spacing parallel to free edge	$s_{2,min}$ [mm]	400	400
Minimum allowable edge distance	$c_{min}$ [mm]	100	100

Table B5: Minimum distances and dimensions in AAC

Anchor type		B-LONG 10
Minimum thickness of member	$h_{min}$ [mm]	100
Single anchor		
Minimum allowable spacing	$a_{min}$ [mm]	250
Minimum allowable edge distance	$c_{min}$ [mm]	100
Anchor group		
Minimum allowable spacing perpendicular to free edge	$s_{1,min}$ [mm]	200
Minimum allowable spacing parallel to free edge	$s_{2,min}$ [mm]	400
Minimum allowable edge distance	$c_{min}$ [mm]	100

Scheme of distances and spacings in masonry and AAC

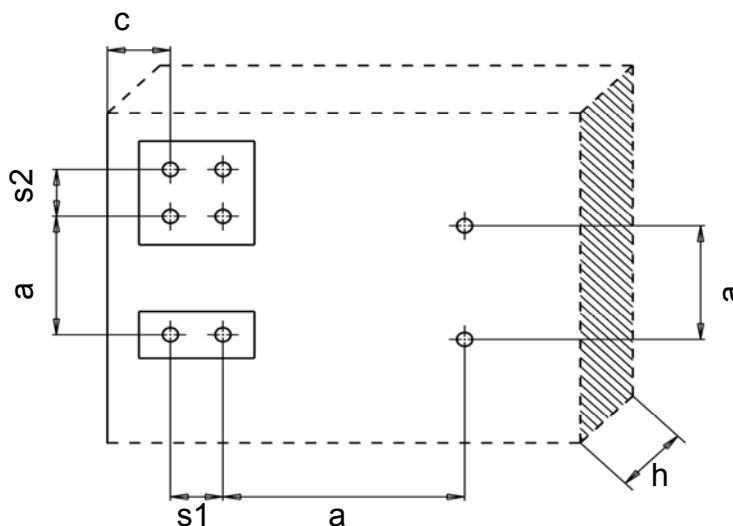

SPIT B-LONG

**Intended use**  
Edge distances and spacings for use in masonry and AAC

Annex B 4

### Installation instructions

Example for B-LONG 8 and B-LONG 10 with  $h_{nom} = 50$  mm

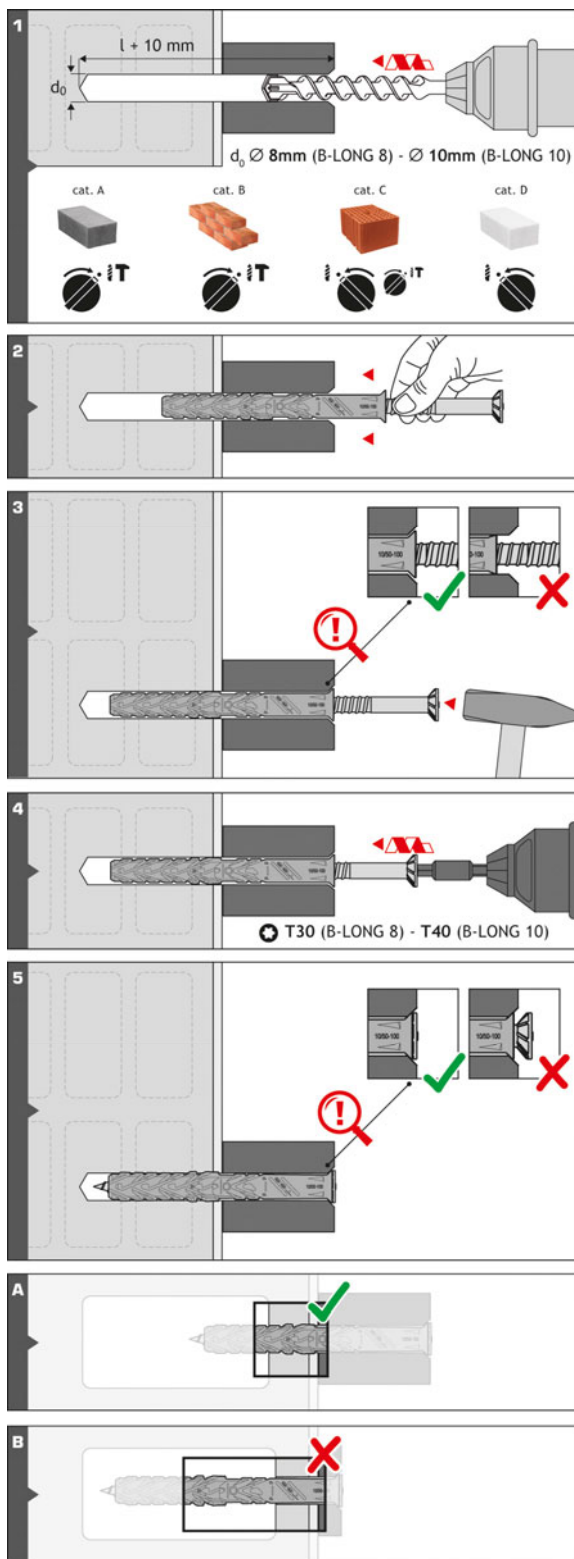

1) Drill the hole considering the drilling method.  
Holes to be cleaned of drilling dust.

2) + 3) The plastic sleeve is inserted through the fixture  
by slight hammer blows.

4) + 5) The special screw is screwed in until the head of  
the screw touches the sleeve. The anchor is  
correct mounted, if there is no turn-through of the  
plastic sleeve in the drill hole and if slightly move  
on turning of the screw is impossible after the  
complete turn-in of the screw.

A) + B) Observation of the overall plastic anchor  
embedment depth.

SPIT B-LONG

**Intended use**  
Installation instructions

Annex B 5

Table C1: Characteristic bending resistance of the screw

Anchor type		B-LONG 8		B-LONG 10	
		galvanised steel	stainless steel	galvanised steel	stainless steel
Characteristic bending resistance	$M_{Rk,s}$ [Nm]	11,13	14,84	16,85	22,46

Table C2: Characteristic resistance of the screw

Failure of expansion element ( special screw )		B-LONG 8		B-LONG 10	
		galvanised steel	stainless steel	galvanised steel	stainless steel
Characteristic tension resistance	$N_{Rk,s}$ [kN]	13,74	18,32	18,11	24,15
Characteristic shear resistance	$V_{Rk,s}$ [kN]	6,87	9,16	9,06	12,08

Table C3: Characteristic resistance for use in concrete (hammer drilling)

Pull-out failure ( plastic sleeve )		B-LONG 8		B-LONG 10		B-LONG 10	
		$h_{nom} = 50$		$h_{nom,1} = 40$		$h_{nom,2} = 50$	
Temperature range		30/50 °C	50/80 °C	30/50 °C	50/80 °C	30/50 °C	50/80 °C
Concrete C12/15							
Characteristic tension resistance	$N_{Rk,p}$ [kN]	2	2	2,5	2	4	3
Concrete $\geq$ C20/25							
Characteristic tension resistance	$N_{Rk,p}$ [kN]	3	2,5	3,5	3	5,5	4

Table C4: Displacements under tension and shear loading in concrete and masonry

Anchor type	$h_{nom}$ [mm]	Tension load			Shear load		
		F [kN]	$\delta_{N0}$ [mm]	$\delta_{N\infty}$ [mm]	F [kN]	$\delta_{V0}$ [mm]	$\delta_{V\infty}$ [mm]
concrete							
B-LONG 8	50	1,0	0,14	0,14	1,7	0,94	1,41
B-LONG 10	40	1,2	0,21	0,07	2,0	0,55	0,83
B-LONG 10	50	2,2	0,12	0,19	3,1	1,08	1,62
solid masonry							
B-LONG 8	50	1,0	0,12	0,24	1,0	0,83	1,25
B-LONG 10	50	1,0	0,39	0,77	1,0	0,83	1,25
hollow or perforated masonry							
B-LONG 8	50	0,26	0,57	1,14	0,34	0,29	0,43
B-LONG 10	50	0,34	0,55	1,10	0,34	0,29	0,43
B-LONG 10	70	0,26	0,09	0,18	0,34	0,29	0,43

SPIT B-LONG

**Performances**

Characteristic resistance of the screw, characteristic resistance for use in concrete

Annex C 1

Table C5: B-LONG 8 - characteristic resistance  $F_{Rk}$  in [kN] in solid masonry (use category "b")

Base Material [Supplier / Title]	minimum size (L x W x H) [mm]	Bulk density class $\rho$ [kg/dm <sup>3</sup> ]	Minimum compressive strength $f_b$ [N/mm <sup>2</sup> ]	Drill method	Thickness of the wall h [mm]	Characteristic resistance $F_{Rk}$ $h_{nom} = 50$ mm	
						30/50°C	50/80°C
Clay brick EN 771-1:2011 HD brick	237x110x54	≥ 1,6	20	hammer	110	3	3
					240	3,5	3,5
			10		110	2	2
					240	2,5	2,5
Clay brick EN 771-1:2011 e.g. Wienerberger Poroton MZ-NF	240x115x71	≥ 1,8	20	hammer	110	3	3
					240	3,5	3,5
			10		110	2	2
					240	2,5	2,5

Table C6: B-LONG 10 - characteristic resistance  $F_{Rk}$  in [kN] in solid masonry (use category "b")

Base Material [Supplier / Title]	minimum size (L x W x H) [mm]	Bulk density class $\rho$ [kg/dm <sup>3</sup> ]	Minimum compressive strength $f_b$ [N/mm <sup>2</sup> ]	Drill method	Thickness of the wall h [mm]	Characteristic resistance $F_{Rk}$ $h_{nom} = 50$ mm	
						30/50°C	50/80°C
Clay brick EN 771-1:2011 e.g. Danesi HD brick	237x110x54	≥ 1,6	20	hammer	110	3	3
					240	3,5	3,5
			10		110	2	2
					240	2,5	2,5
Clay brick EN 771-1:2011 e.g. Wienerberger Poroton MZ-NF	240x115x71	≥ 1,8	20	hammer	110	3	3
					240	3,5	3,5
			10		110	2	2
					240	2,5	2,5

SPIT B-LONG

**Performances**

Characteristic resistance for use in solid masonry

Annex C 2

Table C7: B-LONG 8 - characteristic resistance  $F_{Rk}$  in [kN] in hollow or perforated masonry  
(use category "c" ) with  $h_{nom,2} = 50$  mm

Base Material [Supplier / Title]	minimum size (L x W x H)  [mm]	Bulk density class  $\rho$ [kg/dm <sup>3</sup> ]	Minimum compressive strength  $f_b$ [N/mm <sup>2</sup> ]	Drill method	Characteristic resistance $F_{Rk}$ $h_{nom,2} = 50$ mm	
					30/50°C	50/80°C
Vertically perforated clay brick EN 771-1:2011 e.g. Dosson Doppio Uni see Annex B 2; Fig. 1	250x120x190	≥ 0,9	20	rotary	1,5	0,9
Vertically perforated clay brick EN 771-1:2011 e.g. Wienerberger Porotherm Bioplan see Annex B 2; Fig. 2	300x250x249	≥ 0,8	12	rotary	2	1,5
Vertically perforated clay brick EN 771-1:2011 e.g. Dosson Alveolater see Annex B 2; Fig. 3	300x250x190	≥ 0,8	12	rotary	1,2	0,9
Concrete hollow block EN 771-3:2011 e.g. Fabemi Creux B40 see Annex B 2; Fig. 4	500x200x200	≥ 0,9	4	rotary	1,5	0,9
Concrete hollow block EN 771-3:2011 e.g. KLB Plan Hohlblock see Annex B 2; Fig. 5	497x249x175	≥ 1,0	5	rotary	1,5	1,2

SPIT B-LONG

**Performances**

Characteristic resistance for use in hollow or perforated masonry

Annex C 3

Table C8: B-LONG 10 - characteristic resistance  $F_{Rk}$  in [kN] in hollow or perforated masonry  
(use category "c") with  $h_{nom,2} = 50$  mm

Base Material [Supplier / Title]	minimum size (L x W x H)  [mm]	Bulk density class  $\rho$ [kg/dm <sup>3</sup> ]	Minimum compressive strength  $f_b$ [N/mm <sup>2</sup> ]	Drill method	Characteristic resistance $F_{Rk}$ $h_{nom,2} = 50$ mm	
					30/50°C	50/80°C
Vertically perforated clay brick EN 771-1:2011 e.g. Dosson Doppio Uni see Annex B 2; Fig. 1	250x120x190	≥ 0,9	20	rotary	1,5	1,2
Vertically perforated clay brick EN 771-1:2011 e.g. Wienerberger Porotherm Bioplan see Annex B 2; Fig. 2	300x250x249	≥ 0,8	12	rotary	2	1,5
Vertically perforated clay brick EN 771-1:2011 e.g. Dosson Alveolater see Annex B 2; Fig. 3	300x250x190	≥ 0,8	12	rotary	1,2	0,9
Concrete hollow block EN 771-3:2011 e.g. Fabemi Creux B40 see Annex B 2; Fig. 4	500x200x200	≥ 0,9	4	rotary	1,2	0,9
Concrete hollow block EN 771-3:2011 e.g. KLB Plan Hohlblock see Annex B 2; Fig. 5	497x249x175	≥ 1,0	5	rotary	1,5	1,2

SPIT B-LONG

**Performances**

Characteristic resistance for use in hollow or perforated masonry

Annex C 4



Table C9: B-LONG 8 - characteristic resistance  $F_{Rk}$  in [kN] in hollow or perforated masonry  
(use category "c") with  $h_{nom,3} = 70$  mm

Base Material [Supplier / Title]	minimum size (L x W x H)  [mm]	Bulk density class  $\rho$ [kg/dm <sup>3</sup> ]	Minimum compressive strength  $f_b$ [N/mm <sup>2</sup> ]	Drill method	Characteristic resistance $F_{Rk}$ [kN] $h_{nom,3} = 70$ mm	
					30/50°C	50/80°C
Vertically perforated clay brick EN 771-1:2011 e.g. Dosson Alveolater see Annex B 2; Fig. 3	300x250x190	≥ 0,8	12	rotary	1,2	0,9

Table C10: B-LONG 10 - characteristic resistance  $F_{Rk}$  in [kN] in hollow or perforated masonry  
(use category "c") with  $h_{nom,3} = 70$  mm

Base Material [Supplier / Title]	minimum size (L x W x H)  [mm]	Bulk density class  $\rho$ [kg/dm <sup>3</sup> ]	Minimum compressive strength  $f_b$ [N/mm <sup>2</sup> ]	Drill method	Characteristic resistance $F_{Rk}$ [kN] $h_{nom,3} = 70$ mm	
					30/50°C	50/80°C
Vertically perforated clay brick EN 771-1:2011 e.g. Dosson Alveolater see Annex B 2; Fig. 3	300x250x190	≥ 0,8	12	rotary	1,2	0,9

SPIT B-LONG

**Performances**  
Characteristic resistance for use in hollow or perforated masonry

Annex C 5

Table C11: B-LONG 10 characteristic resistance  $F_{Rk}$  in [kN] in autoclaved aerated concrete (AAC)  
(use category "d")

Base material	Bulk density $\rho$ [kg/m <sup>3</sup> ]	Minimum compressive strength $f_{ck}$ [N/mm <sup>2</sup> ]	Drill method	Characteristic resistance $F_{Rk}$ [kN] B-LONG 10		Characteristic resistance $F_{Rk}$ [kN] B-LONG 10	
				$h_{nom,2} = 50$ mm		$h_{nom,3} = 70$ mm	
				30/50 °C	50/80 °C	30/50 °C	50/80 °C
LS AAC YTONG "clima" block EN 771-4:2011 minimum size [cm] 62,5x25x24	≥ 350	2	rotary	0,6	0,3	0,6	0,5
HS AAC YTONG "sismico" block EN 771-4:2011 minimum size [cm] 62,5x25x24	≥ 500	4	rotary	1,5	1,2	2	1,5

Table C12: Displacements under tension and shear loading in autoclaved aerated concrete AAC

Anchor type B-LONG 10	Tension load			Shear load		
	F [kN]	$\delta_{N0}$ [mm]	$\delta_{N\infty}$ [mm]	F [kN]	$\delta_{V0}$ [mm]	$\delta_{V\infty}$ [mm]
LS AAC YTONG "clima" block EN 771-4:2011 minimum size [cm] 62,5x25x24	0,2	0,08	0,16	0,2	0,43	0,64
HS AAC YTONG "sismico" block EN 771-4:2011 minimum size [cm] 62,5x25x24	0,5	0,46	0,92	0,5	1,43	2,14

SPIT B-LONG

**Performances**  
Characteristic resistance and displacements for use in autoclaved aerated concrete

Annex C 6