

DE	Gebrauchsanleitung / Montageanleitung	2
FR	Mode d'emploi / Instructions de montage	3
EN	Instructions for use / assembly instructions	4
IT	Istruzioni per l'uso / Istruzioni per Installazione	5
ES	Modo de empleo / Instrucciones de montaje	6
NL	Gebruiksaanwijzing / Handleiding	7
DK	Brugsanvisning / Monteringsvejledning	8
PT	Instruções para uso / Manual de Instalação	9
PL	Instrukcja obsługi / Instrukcja montażu	10
CS	Návod k použití / Montážní návod	11
SK	Návod na použitie / Montážny návod	12
ZH	用户手册 / 组装说明	13
RU	Руководство пользователя / Инструкция по монтажу	14
FI	Käyttöohje / Asennusohje	15
SV	Bruksanvisning / Monteringsanvisning	16
LT	Vartotojo instrukcija / Montavimo instrukcijos	17
HR	Upute za uporabu / Uputstva za instalaciju	18
TR	Kullanım kılavuzu / Montaj kılavuzu	19
RO	Manual de utilizare / Instrucțiuni de montare	20
EL	Οδηγίες χρήσης / Οδηγία συναρμολόγησης	21
SL	Navodilo za uporabo / Navodila za montažo	22
ET	Kasutusjuhend / Paigaldusjuhend	23
LV	Lietošanas pamācība / Montāžas instrukcija	24
SR	Uputstvo za upotrebu / Uputstvo za montažu	25
NO	Bruksanvisning / Montasjeveiledning	26
BG	Инструкция за употреба / Ръководство за монтаж	27
SQ	Udhëzuesi i përdorimit / Udhëzime rreth montimit	28
AR	دليل الاستخدام / تعليمات التجميع	29
HU	Használati útmutató / Szerelési útmutató	30

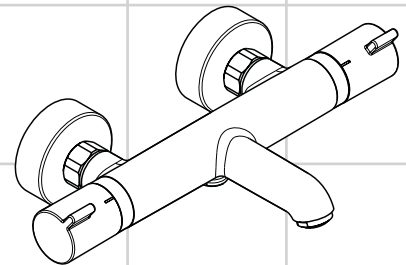

Ecostat Comfort HQ

13112000

Ecostat Comfort

13114XXX

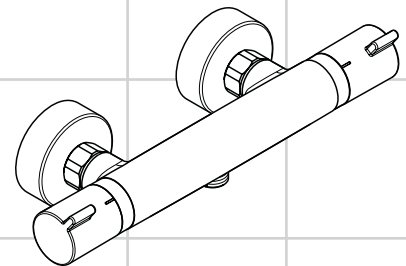

Ecostat Comfort HQ

13113000

Ecostat Comfort

13116XXX

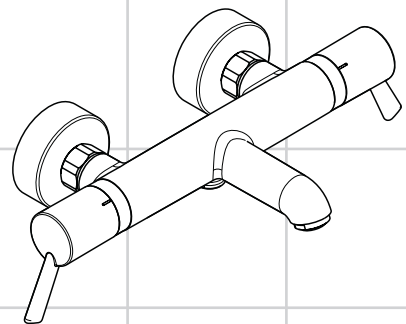

Ecostat Comfort Care

13115000

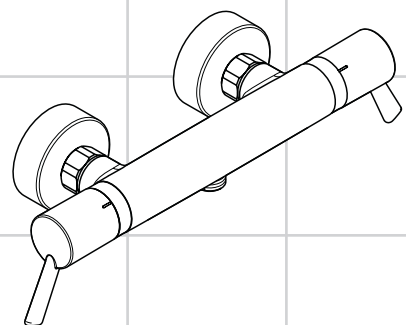

Ecostat Comfort Care

13117000



Sikkerhetshenvisninger

- △ Bruk hansker under montasjen for å unngå klem- og kuttskader.
- △ Produktet skal kun brukes for bade-, hygiene- og kroppshygiene.
- △ Produktet skal ikke brukes som holdegrep. Det skal monteres en separat holdegrep.
- △ Barn og voksne med fysiske og psykiske og/eller sensoriske handicap skal ikke bruke dusjsystemet uten oppsyn. Personer som er påvirket av alkohol eller narkotika skal ikke bruke dusjsystemet.
- △ Store trykkdifferanser mellom kaldt- og varmtvannstilkoblinger skal utlignes.

Montagehenvisninger

- Før montasjen skal produktet sjekkes for transportskader. Etter monteringen aksepteres ikke noen transport- eller overflateskader.
- Ledningene og armaturen skal monteres, spyles og sjekkes iht. de gyldige normer.
- Gjeldende retningslinjer for rørleggerarbeid i de enkelte land skal følges.
- Produktet er ikke påtenkt for bruk sammen med et dampbad!

ECOSTAT i forbindelse med gjennomstrømningsvarmer.

- Når det tilkobles en hånddusj, skal en eventuell allerede innbygd drossel i hånddusjen fjernes.
- Når det oppstår problemer med gjennomstrømningsvarmer eller ved store trykkdifferanser skal det monteres en drossel i kaldtvannsforsyningen. Denne kan leveres som ekstrautstyr (artikkelnummer 97510000).

Tekniske data

Driftstrykk	maks. 1 MPa
Anbefalt driftstrykk:	0,1 - 0,5 MPa
Prøvetrykk	1,6 MPa
	(1 MPa = 10 bar = 147 PSI)
Varmtvannstemperatur	maks. 70 °C
Anbefalt temperatur for varmt vann	65 °C
Tilkoblingsmål:	150±12 mm
Tilkoblinger G 1/2:	kaldt høyre - varm venstre
Termisk desinfisering:	maks. 70 °C / 4 min

- Egensikker mot tilbakeflyt
- Produktet er utelukkende designet for drikkevann!

Symbolbeskrivelse



Ikke bruk silikon som inneholder eddiksyre!



Justering (se side 32)

Etter avsluttet montering skal termostatens utløpstemperatur kontrolleres. Det er nødvendig med korrektur når temperaturen målt ved uttaksstedet avviker fra temperaturen som er innstilt på termostaten.

max. ≈ 42 °C Safety Function (se side 32)

Takket være egenskapen "Safety Function" kan det forhåndsinnstilles en ønsket maks. temperatur, f.eks. 42 °C.



Rengjøring (se side 34)



Vedlikehold (se side 34)

- Funksjonen til returløpssperren skal iht. DIN EN 1717 og i samsvar med de nasjonale og lokale forskrifter sjekkes regelmessig (minst en gang i året).
- For å holde regulerings-enheten bevegelig, skal termostaten stilles fra tid til annen på helt varmt og helt kaldt.)



Mål (se side 35)



Gjennomstrømningsdiagram (se side 35)

- ① Utgang dusj
- ② Utgang kar



Servicedeler (se side 36)

XXX = Fargekode
 000 = Krom
 340 = Brushed Black Chrome
 670 = Matt Black
 700 = Matt White
 800 = Rustfritt Stål Optikk
 990 = Gull-Optikk



Betjening (se side 33)



Prøvermerke (se side 31)

Feil	Årsak	Feilrettelse
Lite vann	- Forsyningsstrykk er ikke tilstrekkelig - Smussfangersil til reguleringsenheten skitten.	- Ledningsstrykk sjekkes - Smussfangersil før termostaten og på reguleringsenheten rengjøres
Krysstrømning, varmt vann presses ved lukket armatur inn i kaldtvannsledning eller omvendt	- Dusjens silpakning er skitten - Returløpstopper skitten / defekt	- Silpakning mellom dusj og slangen rengjøres - Returløpstopper rengjøres, byttes hvis nødvendig
Utløpstemperatur samsvarer ikke med innstilt temperatur	- Termostat ble ikke justert - For lav varmtvannstemperatur	- Termostat justeres - Varmtvannstemperatur økes til mellom 42 °C og 65 °C
Temperaturregulering er ikke mulig	- reguleringsenhet forkalket - Smuss eller avleiringer på tetningen, avsperrings-overdel skadet	- reguleringsenhet byttes - Avsperrings-overdel rengjøres hhv. Byttes
gjennomstrømningsvarmer innkobler ikke under termostatdrift	- Smussfangersil skitten - Returløpstopper sitter fast - Drossel til hånddusjen ikke fjernet	- Smussfangersil rengjøres / byttes - Returløpstopper byttes - Drossel fjernes fra hånddusjen
Dusj eller utløp drypper	- Smuss eller avleiringer på tetningen, avsperrings-overdel skadet	- Avsperrings-overdel rengjøres hhv. Byttes

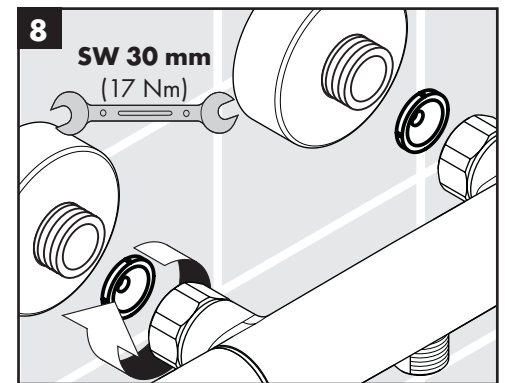
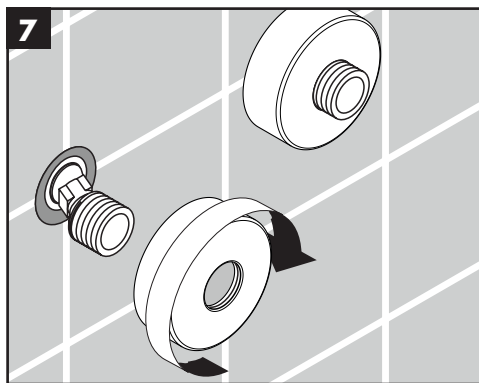
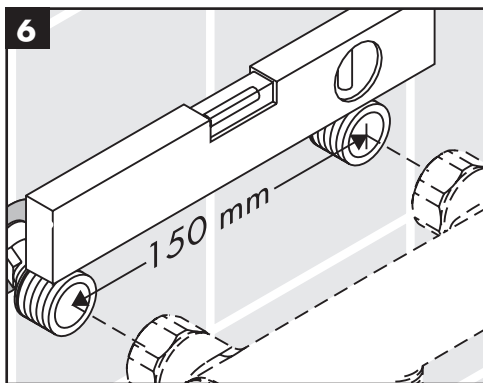
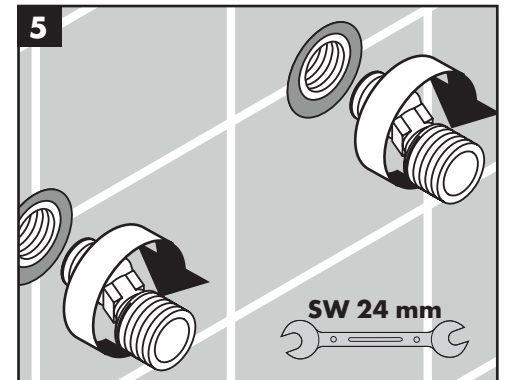
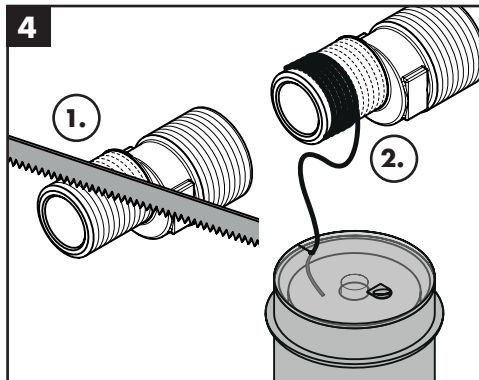
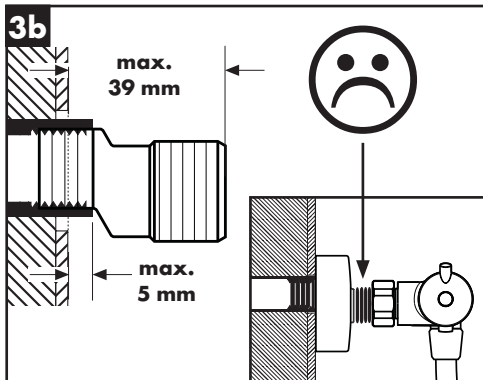
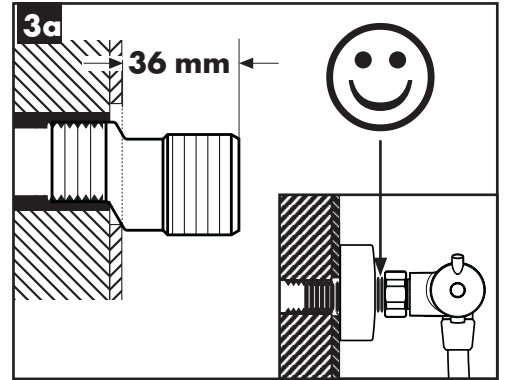
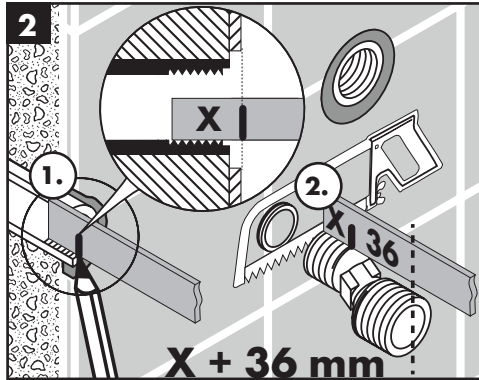
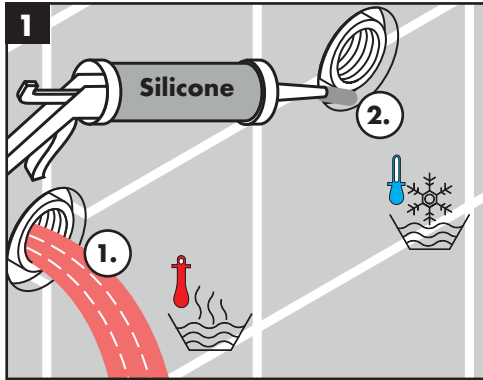

	P-IX	DVGW	SE 4	SVGW	ACS	NF	WRAS	KIWA		ETA
13112000	PA-IX 19693/ICB	CN0422	1377		X		X	X		1.43/20147
13113000	PA-IX 19692/IB	CN0422	1377		X		X	X		1.43/20148
13114000	PA-IX 19693/ICB	CN0422	1377		X		X	X		1.43/20147
13115000	PA-IX 19693/ICB	CN0422	1377		X		X	X		1.43/20147
13116000	PA-IX 19692/IB	CN0422	1377		X		X	X		1.43/20148
13117000	PA-IX 19692/IB	CN0422	1377		X		X	X		1.43/20148

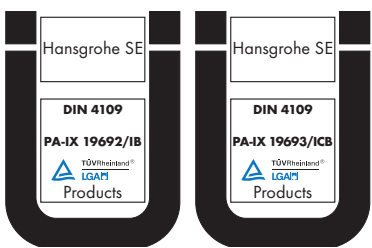

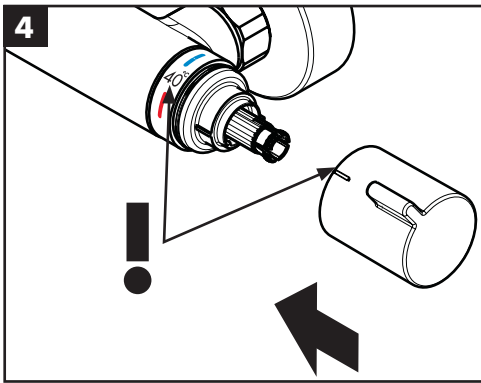
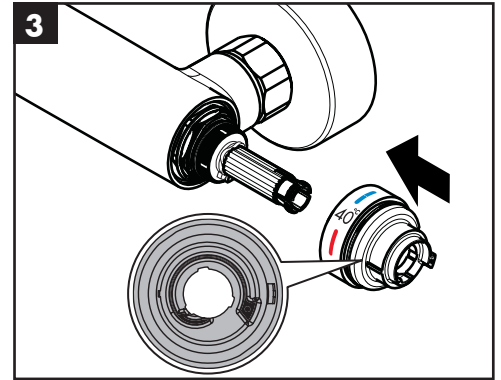
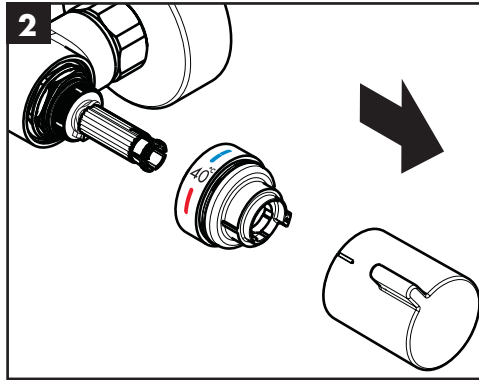
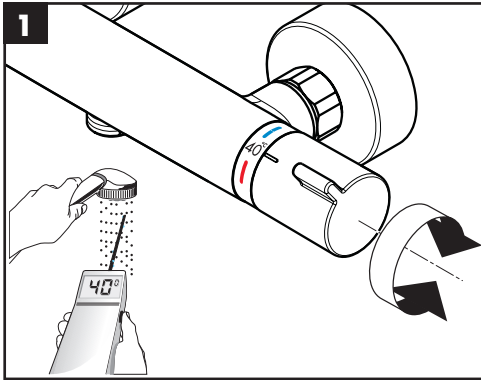

max.
≈ 42° C

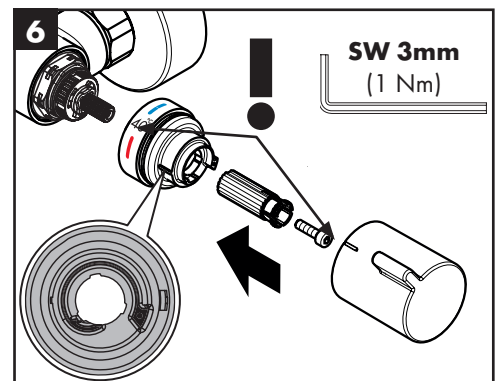
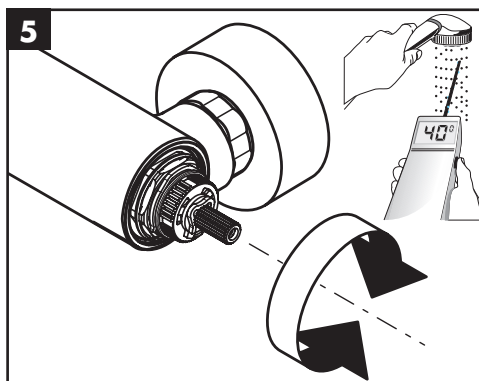
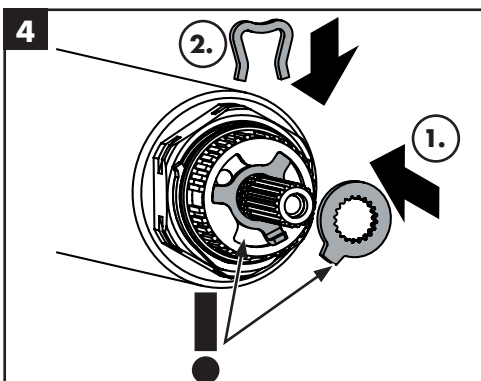
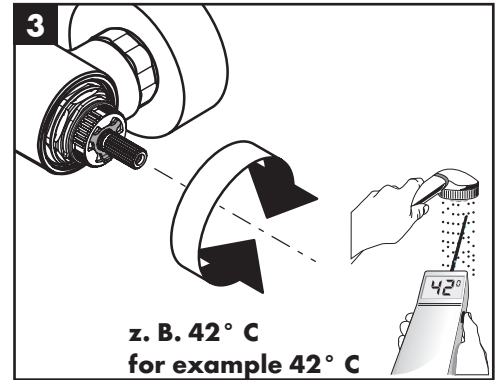
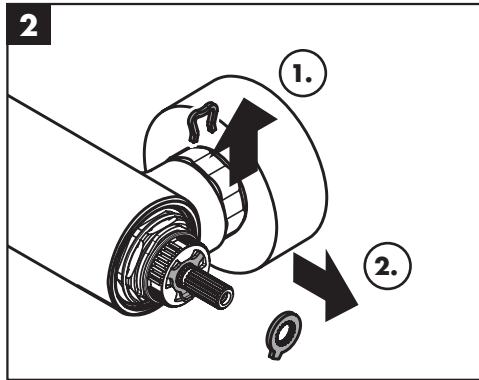
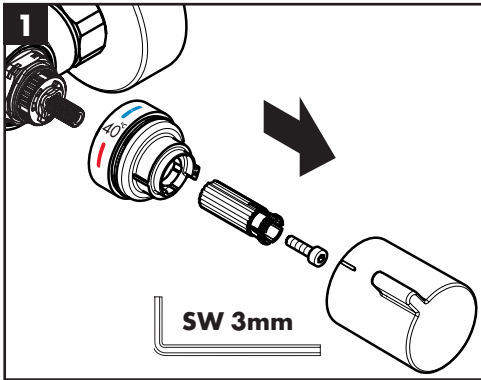

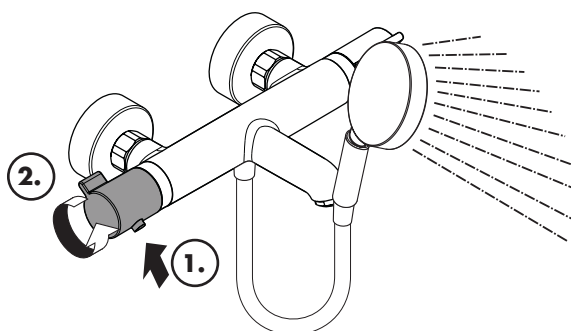
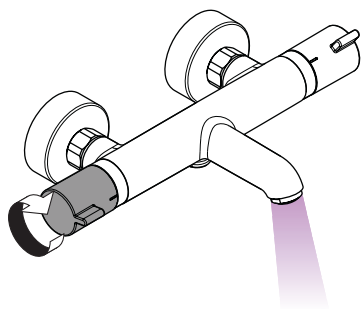

öffnen / ouvert / open / aperto / abierto / open / åbne / abrir / otworzyć / otevřít / otvorit / 开 / открыть / nyítás / avaaminen / öppna / atidaryti / Otvaranje / açmak / deschide / ανοικτό / odpreti / avage / atvērt / otvoriti / åpne / отварање / hare / فتح

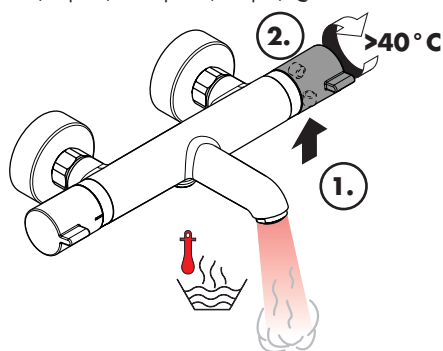

warm / chaud / hot / caldo / caliente / warm / varmt / quente / ciepła / teplá / teplá / 热 / горячая / meleg / lämmin / varmt / karštas / Vruća voda / sıcak / cald / ζεστό / toplo / kuum / karsts / topla / varm / топло / i ngrohtë / ساخن

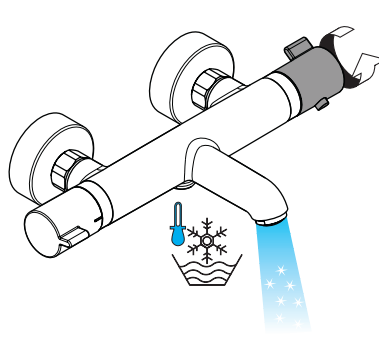

kalt / froid / cold / freddo / frío / koud / koldt / fría / zimna / studená / studená / 冷 / холодная / hideg / kylmä / kallt / šaltas / Hladno / soğuk / reze / κρύο / mrzlo / külm / auksts / hladno / kaldt / студено / i ftohtë / با

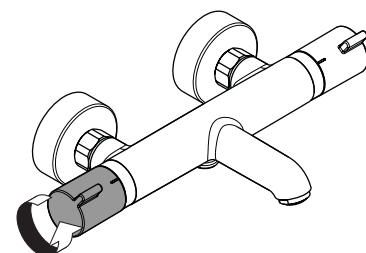

schließen / fermé / close / chiudere / cerrar / sluiten / lukke / fechar / zamknąć / zavřít / uzavrieť / 关 / закрыть / bezárás / sulkeminen / stänga / uždaryti / Zatvaranje / kapatmak / închide / κλειστό / zarpeti / sulgege / aizvērt / zatvori / lukke / затваряне / mbylle / إغلاق

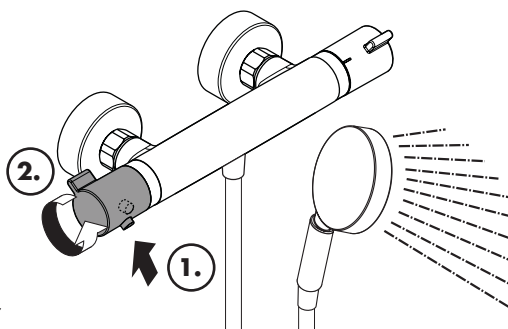
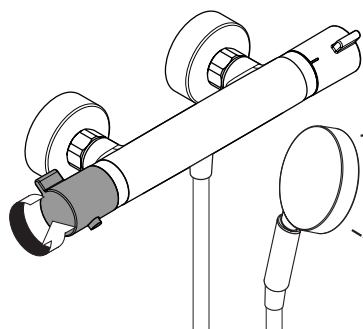

öffnen / ouvert / open / aperto / abierto / open / åbne / abrir / otworzyć / otevřít / otvorit / 开 / открыть / nyítás / avaaminen / öppna / atidaryti / Otvaranje / açmak / deschide / ανοικτό / odpreti / avage / atvērt / otvoriti / åpne / отварање / hare / فتح

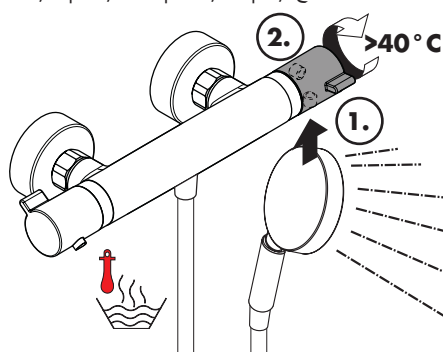

warm / chaud / hot / caldo / caliente / warm / varmt / quente / ciepła / teplá / teplá / 热 / горячая / meleg / lämmin / varmt / karštas / Vruća voda / sıcak / cald / ζεστό / toplo / kuum / karsts / topla / varm / топло / i ngrohtë / ساخن

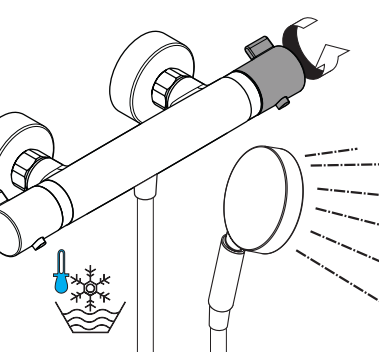

kalt / froid / cold / freddo / frío / koud / koldt / fría / zimna / studená / studená / 冷 / холодная / hideg / kylmä / kallt / šaltas / Hladno / soğuk / reze / κρύο / mrzlo / külm / auksts / hladno / kaldt / студено / i ftohtë / با

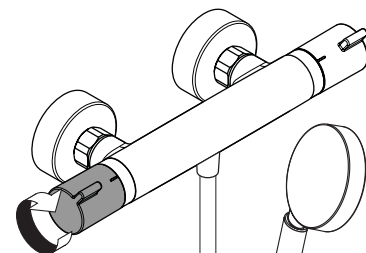

schließen / fermé / close / chiudere / cerrar / sluiten / lukke / fechar / zamknąć / zavřít / uzavrieť / 关 / закрыть / bezárás / sulkeminen / stänga / uždaryti / Zatvaranje / kapatmak / închide / κλειστό / zarpeti / sulgege / aizvērt / zatvori / lukke / затваряне / mbylle / إغلاق



www.hansgrohe.com/
cleaning-recommendation

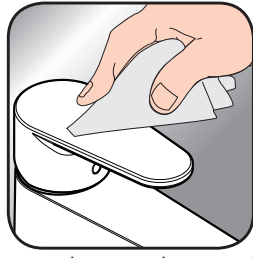

www.hansgrohe.com/
cleaning-recommendation



www.hansgrohe.com/
cleaning-recommendation



www.hansgrohe.com/
cleaning-recommendation

DE Reinigungsempfehlung / Garantie / Kontakt

FR Recommandation pour le nettoyage / Garanties / Contact

EN Cleaning recommendation / Warranty / Contact

IT Raccomandazione di pulizia / Garanzia / Contatto

ES Recomendaciones para la limpieza / Garantía / Contacto

NL Aanbevelingen inzake reiniging / Garantie / Contact

DK Rensning, anbefaling / Garanti / Kontakt

PT Recomendações de limpeza / Garantia / Contacto

PL Zalecenie dotyczące pielęgnacji / Gwarancja / Kontakt

CS Doporučení k čištění / Záruka / Kontakt

SK Odporúčania pre čistenie / Záruka / Kontakt

ZH 清洁指南 / 担保 / 接触

RU Рекомендации по очистке / Гарантия / Контакты

HU Tisztítási tanácsok / Garancia / érintkezés

F Puhdistussuositus / Takuu / Kosketus

SV Rengöringsrekommendationer / Garanti / Kontakt

LT Valymo rekomendacijos / Garantija / Kontaktai

HR Preporuke za čišćenje / Garancija / Kontakt

TR Temizleme önerisi / Garanti / Temas

RO Recomandări pentru curățare / Garanție / Contact

EL Σύσταση καθαρισμού / Εγγύηση / επαφή

SL Priporočilo za čiščenje / Garancija / Kontakt

ET Puhastussuovitused / Garantii / Kontakt

LV Tīrīšanas ieteikumi / Garantija / Kontakti

SR Preporuke za čišćenje / Garancija / Kontakt

NO Anbefaling for rengjøring / Garanti / Kontakt

BG Препоръка за почистване / Гаранция / Контакт

SQ Këshilla rreth pastrimit / Garancia / Kontakt

KO 세정시 권장사항 / 품질보증 / 접촉

AR توصيات التنظيف / الضمان (الولايات المتحدة الأمريكية) / اتصال

max.
≈ 42°C

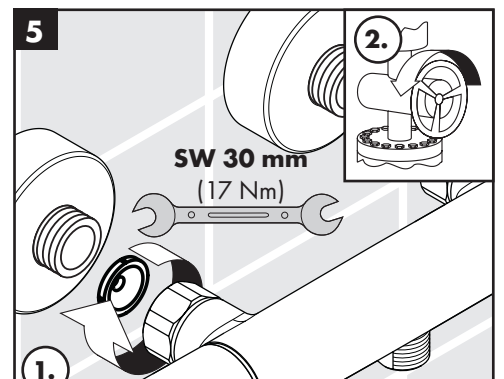
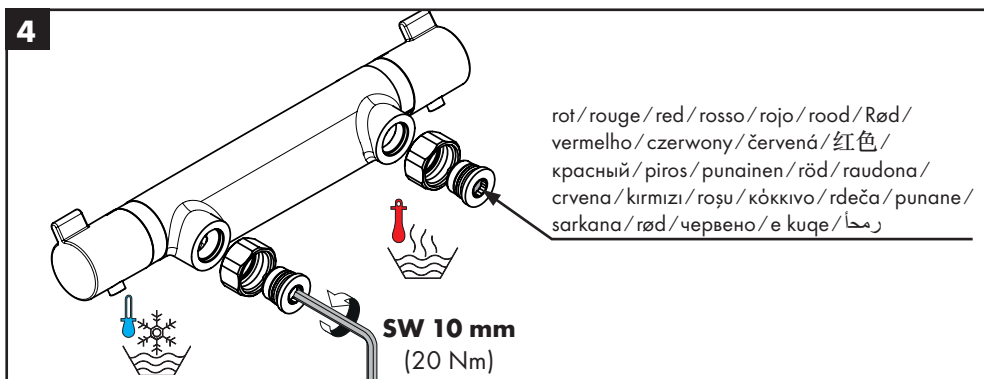
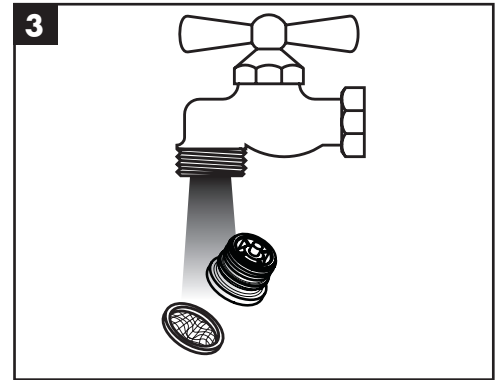
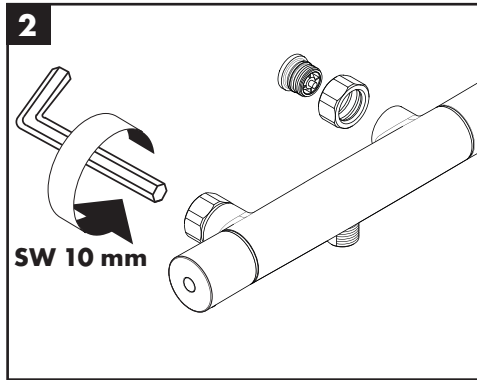
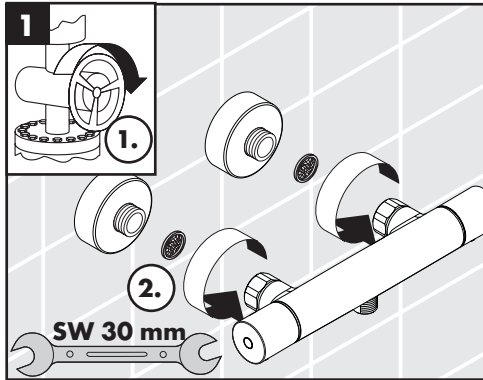

Ecostat Comfort HQ
13112000

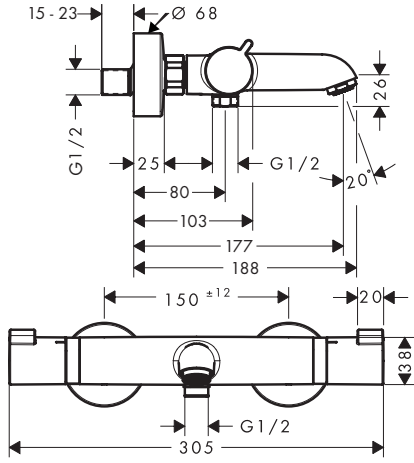

Ecostat Comfort HQ
13113000

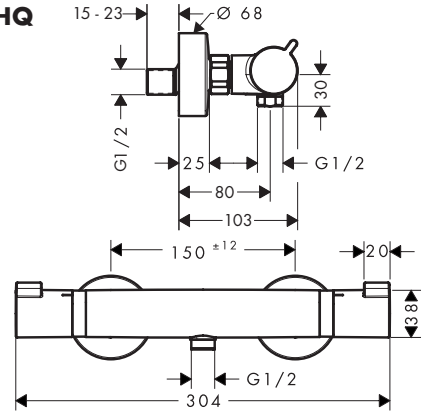

Ecostat Comfort
13114XXX

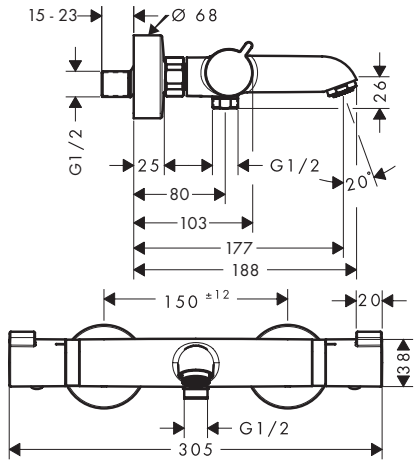

Ecostat Comfort
13116XXX

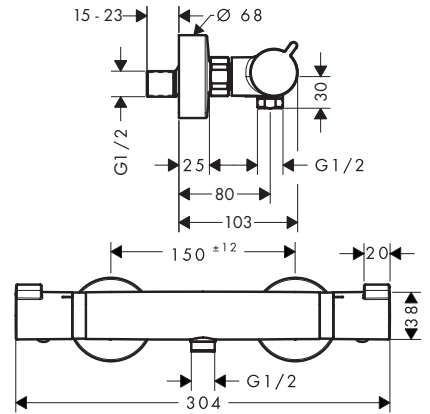

Ecostat Comfort Care
13115000

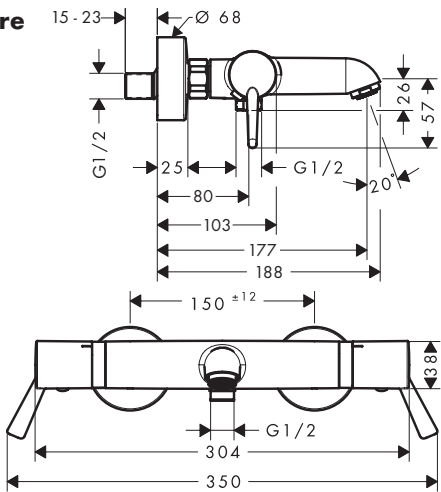

Ecostat Comfort Care
13117000

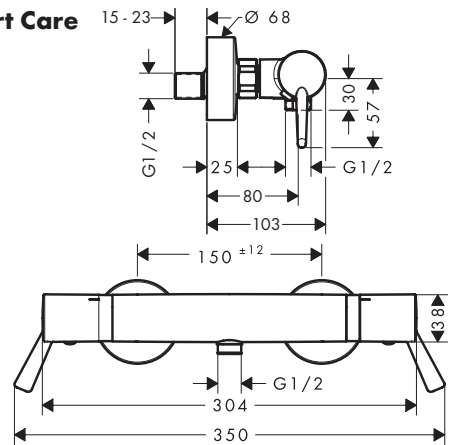

Ecostat Comfort HQ 13112000
Ecostat Comfort 13114XXX
Ecostat Comfort Care 13115000

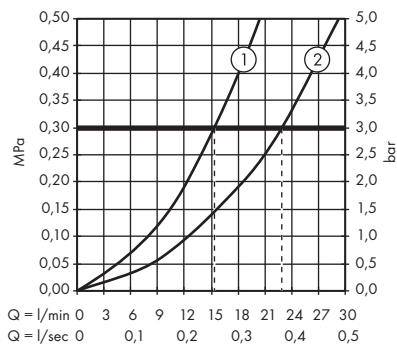

Ecostat Comfort HQ 13113000
Ecostat Comfort 13116XXX
Ecostat Comfort Care 13117000

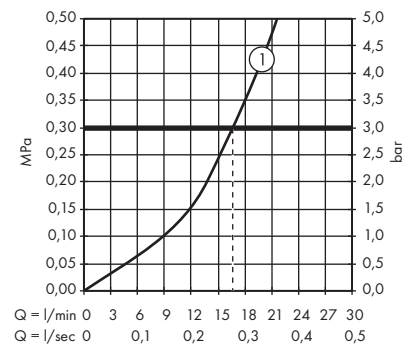



Ecostat Comfort 13114XXX

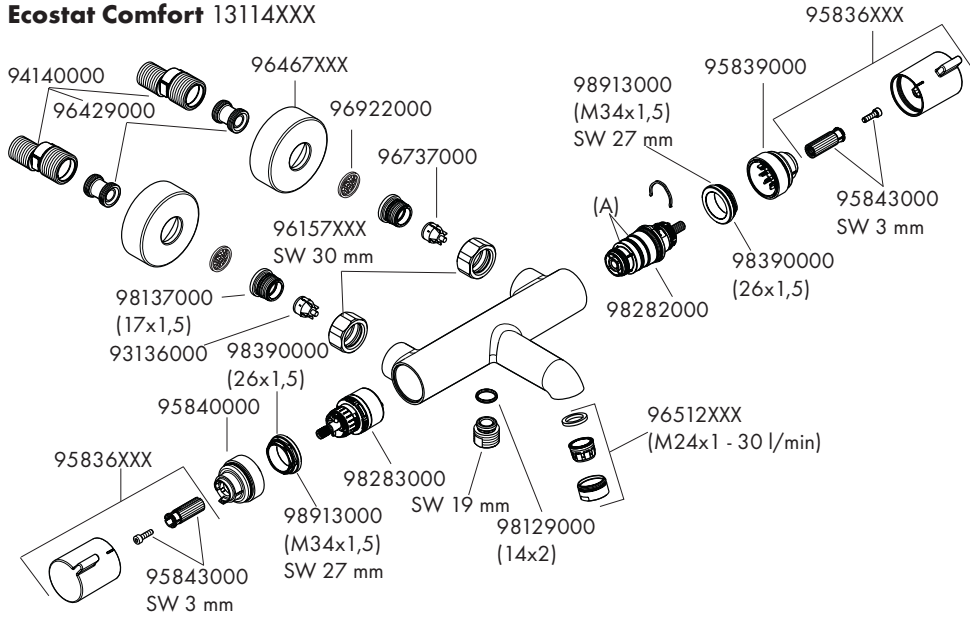

Ecostat Comfort HQ 13112000

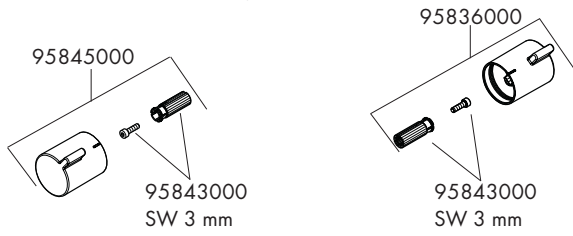

Ecostat Comfort Care 13115000

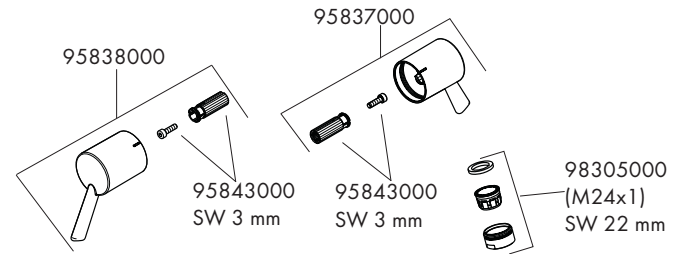

Ecostat Comfort 13116XXX

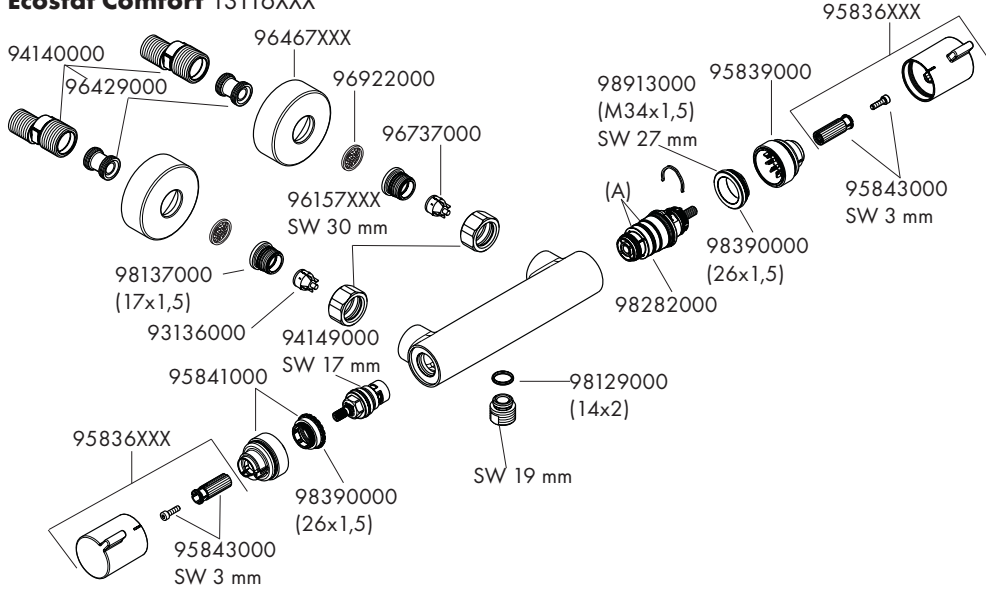

Ecostat Comfort HQ 13113000

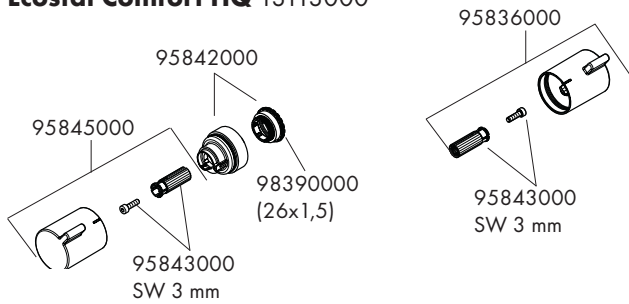

Ecostat Comfort Care 13117000

