

# Installation Manual

Montageanleitung  
Instructions de montage  
Istruzioni per il montaggio

**KNOW  
HOW**  
INSTALLED





**GEFAHR**  
**Gefahr eines**  
**elektrischen Schlags**

- ▶ Das Gerät darf nur an Steckdosen oder Festanschlüssen mit Schutzerdung betrieben werden.



**DANGER**  
**Electric shock hazard**

- ▶ The device may only be operated at power outlets or fixed connections with protective earthing.



**DANGER**  
**Risque de décharge**  
**électrique**

- ▶ L'appareil ne doit être raccordé qu'à des prises électriques ou des branchements fixes avec mise à la terre.



**PERICOLO**  
**Pericolo di scossa**  
**elettrica**

- ▶ L'apparecchio può essere utilizzato esclusivamente con prese elettriche o allacciamenti fissi provvisti di messa a terra.



**GEVAAR**  
**Gevaar van een**  
**elektrische schok**

- ▶ Het apparaat mag alleen aan stopcontacten of vaste aansluitingen met randaarding worden gebruikt.



**PELIGRO**  
**Peligro de descarga**  
**eléctrica**

- ▶ El dispositivo debe utilizarse solamente en salidas de corriente o conexiones fijas con puesta a tierra de protección.



## **PERIGO**

### **Perigo de choque eléctrico**

- ▶ O aparelho só pode ser utilizado em tomadas ou ligações fixas com ligação à terra de protecção.



## **FARE**

### **Fare for elektrisk stød**

- ▶ Enheden må kun anvendes på stikdåser eller fastopkoblede forbindelser med arbejdsjording.



## **FARE**

### **Fare for elektrisk støt**

- ▶ Apparatet skal kun drives i stikkontakter eller faste tilkoblinger med jordet ledning.



## **FARA**

### **Risk för elektriska stötar**

- ▶ Apparaten får endast anslutas till eluttag eller fasta anslutningar med skyddsjordning.



## **VAARA**

### **Sähköiskun vaara**

- ▶ Laitetta saa käyttää vain sellaisissa pistorasioissa tai kiinteissä liitännöissä, jotka on maadoitettu.



## **NIEBEZPIECZEŃSTWO**

### **Niebezpieczeństwo porażenia prądem elektrycznym**

- ▶ Urządzenie można eksploatować wyłącznie po podłączeniu do gniazdek elektrycznych lub przyłączy stacjonarnych wyposażonych w uziemienie ochronne.



### **VESZÉLY** **Áramütés veszélye**

- ▶ A készüléket csak védőföldeléssel rendelkező dugaszoló aljzatokkal vagy rögzített csatlakozókkal szabad üzemeltetni.



### **NEBEZPEČENSTVO** **Nebezpečnostvo zásahu elektrickým proudem**

- ▶ Přístroj smie byť prevádzkovaný len vtedy, keď je pripojený k zásuvkám alebo pevným prípojkám s ochranným uzemnením.



### **NEBEZPEČÍ** **Nebezpečí úrazu elektrickým proudem**

- ▶ Přístroj se smí provozovat připojený pouze na zásuvky nebo pevná připojení s ochranným uzemněním.



### **NEVARNOST** **Nevarnost električnega udara**

- ▶ Napravo lahko uporabljate le pri vtičnicah ali stalni priključitvi z ozemljitvijo.



### **OPASNOST** **Opasnost od električnega udara**

- ▶ Uređaj se smije puštati u pogon samo na utičnicama ili fiksnim priključcima sa zaštitnim uzemljenjem.



### **OPASNOST** **Opasnost od strujnog udara**

- ▶ Uređaj sme da se uključuje samo u utičnice ili fiksne priključke sa zaštitnim uzemljenjem.



## **ОПАСНОСТ**

### **Опасност от токов удар**

- ▶ Уредът трябва да функционира само на контакти или постоянни връзки със защитно заземяване.



## **PERICOL**

### **Pericol de electrocutare**

- ▶ Aparatul poate fi dat în exploatare numai dacă este conectat la prize sau conexiuni fixe cu legare la pământ de protecție.



## **TEHLIKE**

### **Elektrik çarpma tehlikesi**

- ▶ Cihaz sadece koruyucu toprak hattı olan prizlerde veya sabit bağlantılarla çalıştırılmalıdır.



## **ОПАСНО**

### **Опасность удара током**

- ▶ Прибор разрешено эксплуатировать только от штепсельных розеток или неразъемных соединений с защитным заземлением.



## **警告**

### **电击危险**

- ▶ 设备仅允许在插入电源插座或带保护性接地的固定接头时运行。

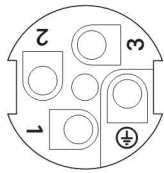

1		L
2		N
3		-

1

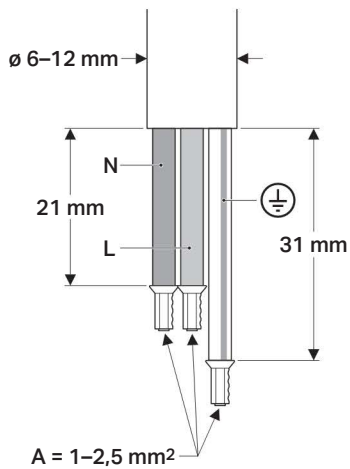

2

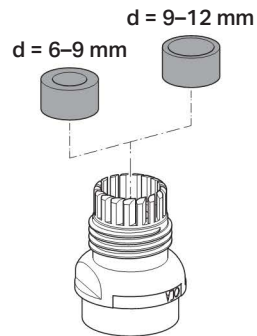
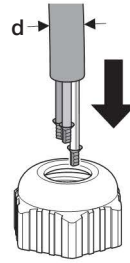

3

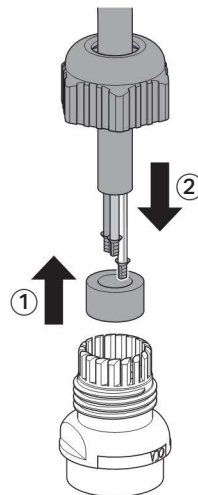

4

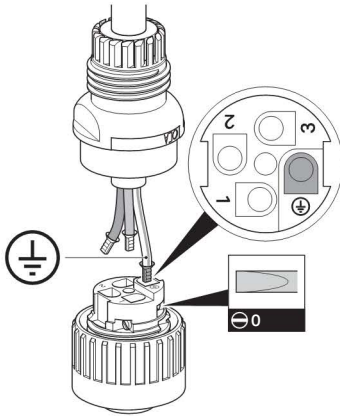

5

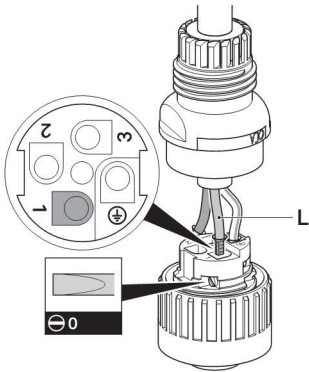

6

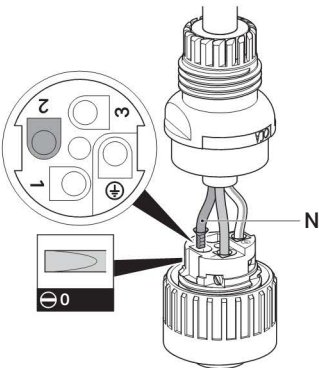

7

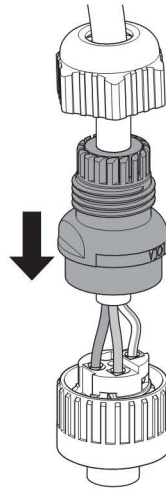

8

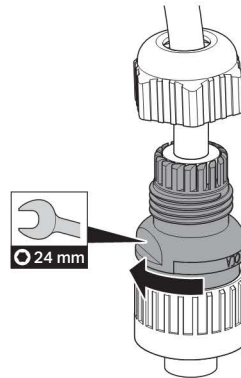

9

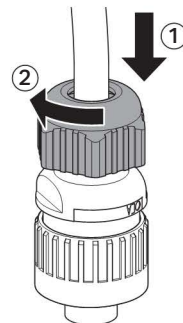

**Geberit International AG**  
**Schachenstrasse 77**  
**CH-8645 Jona**

**T +41 55 221 63 00**  
**F +41 55 221 63 16**  
**documentation@geberit.com**

**→ [www.geberit.com](http://www.geberit.com)**