

ABA NOVA



- ① **Specially designed screw** – Improved idle torque
- ② **Compact housing** – Better and more evenly spread clamping force
- ③ **Mechanically locked** – No welding points
- ④ **Band marking** – Material & size marked on each clamp
- ⑤ **Traceability** code of each clamp

The highly versatile clamp

ABA Nova clamps incorporate a newly designed housing positioned to more evenly distribute a high clamping force and give safer guidance of the emerging band. The short housing saddle also provides optimal contact pressure on the hose.

The New Generation design results in a clamping force reserve that resists breaks for a safe seal connection. In addition, smooth undersides and rolled-up band edges are gentle on the hose and reduce risk of leakage as well.

Advantages at a glance

- High clamping force
- High break torque
- Lower idle torque
- Every clamp is date stamped for traceability
- Requires very low packing space

Materials



The highly versatile ABA Nova clamp is an ideal choice for smaller dimensions of hoses.

Typical applications

- Machine building
- Chemical industry
- Irrigation systems
- Railway
- Agricultural machines
- Building machines
- Marine

ABA Nova Aluzink S20

- The band is made of Aluzink for added corrosion resistance, this gives three times the protection offered by conventional galvanized steel

ABA Nova Stainless S40

- All parts are made of SS 2333/AISI 304 stainless steel

ABA Nova Acid-Resistant S50

- All parts are made of SS 2343/AISI 316 stainless steel
- Natural choice for applications where premium corrosion resistance is required
- This not only ensures premium corrosion resistance, it also prevents abrasion caused by using different material grades.

Dimensions

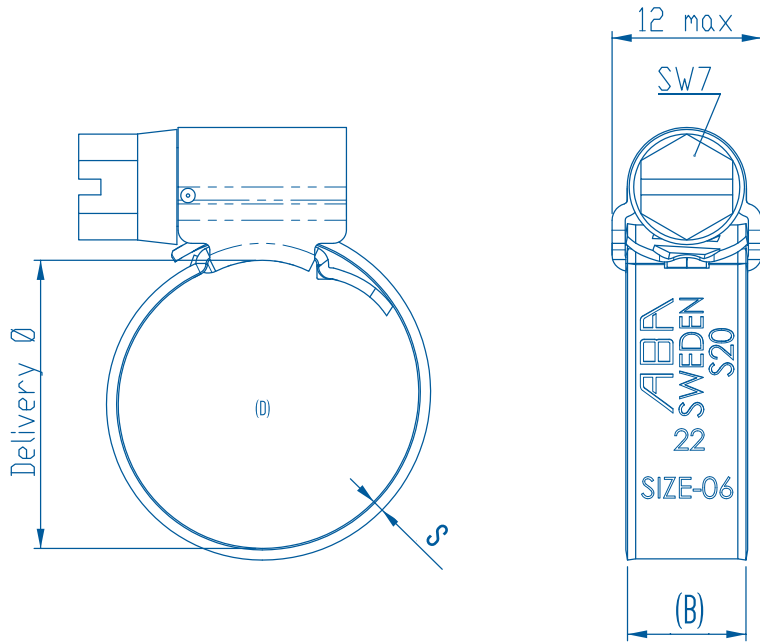

Specifications

ABA NOVA 9 MM						
Width (B mm)	Clamping ranges (D mm)	Clamping ranges (D in.)	Thickness (S mm)	S20 Product No.	S40 Product No.	S50 Product No.
9	8-14	5/16-9/16	0.8	0811 6108 011	0811 6110 011	0811 6112 011
	11-17	7/16-11/16	0.8	0811 6108 014	0811 6110 014	0811 6112 014
	13-20	1/2-13/16	0.8	0811 6108 017	0811 6110 017	0811 6112 017
	15-24	9/16-15/16	0.8	0811 6108 020	0811 6110 020	
	19-28	3/4-11/8	0.8	0811 6108 024	0811 6110 024	
	22-32	7/8-11/4	0.8	0811 6108 027	0811 6110 027	
	26-38	1-1 1/2	0.8	0811 6108 032	0811 6110 032	
	32-44	1 1/4-1 3/4	0.8*	0811 6108 038		
	38-50	1 1/2-2	0.8*	0811 6108 044		
	44-56	1 3/4-2 3/16	0.8*	0811 6108 050		
	50-65	2-2 9/16	0.8*	0811 6108 058		
	58-75	2 1/4-2 15/16	0.8*	0811 6108 067		
	68-85	2 11/16-3 3/8	0.8*	0811 6108 077		
	70-90	2 3/4-3 9/16	0.8*	0811 6109 080		
	80-100	3 1/8-3 15/16	0.8*	0811 6109 090		
	90-110	3 9/16-4 5/16	0.8*	0811 6109 100		
	100-120	3 15/16-4 3/4	0.8*	0811 6109 110		
	110-130	4 5/16-5 1/8	0.8*	0811 6109 120		
	120-140	4 3/4-5 1/2	0.8*	0811 6109 130		
	130-150	5 1/8-5 15/16	0.8*	0811 6109 140		
140-160	5 1/2-6 5/16	0.8*	0811 6109 150			

*1.0 for S20