

**FEATURES:**

- Built-in ISO 5211 Direct Mounting Pad and Square Stem for Easy Automation
- Anti-Static Devices for Ball-Stem-Body
- Blow-out Proof Stem
- Pressure Balance Hole in Ball Slot
- Pre-Load 2 Belleville Washers to Self-adjust Packing
- **TA-LUFT** Design Approved
- Options: 1. Actuator 2. Limit Switch 3. Positioner

**STANDARDS:**

- Design: ASME B16.34, API 608
- Wall Thickness: EN 12516-3
- Pipe Thread **KV-L30**: ASME B1.20.1, BS21  
DIN 2999 / 259, ISO 228 / 1  
JIS B 0203, ISO 7 / 1
- Butt Weld **KV-L31**: ASME B16.25 (φB2 Sch 40)  
φB2 Available in Sch 10, 20
- Socket Weld **KV-L32**: ASME B16.11
- Flanged End **KV-L3F**: ASME B16.5 CLASS 150/300  
DIN 2501 PN10-PN40  
JIS B2238 10K / 20K
- Inspection & Testing: API 598, EN 12266

NO.	PART NAME	MATERIALS
1	Body	CF8M   CF8   WCB
2	Cap (Thread)	CF8M
	Cap (Welding)	CF3M
3	Ball	CF8M   CF8
4	Ball Seat	TFM 1600 / PTFE / RTFE
5	Stem	SUS 316   SUS 304
6	Anti-Static Device	SUS 316   SUS 304
7	Thrust Washer	PTFE
8	O-Ring	FKM (VITON)
9	Stem Packing	PTFE
10	Bushing	50%SS+50%PTFE
11	Gland	SUS 316
12	Belleville Washer	SUS 301
13	Stem Nut	A194-8
14	Stop-Lock-Cap	SUS 304
15	Bolting	A193-B8
16	Bolt Washer	SUS 304
17	Bolt Nut	A194-8
18	Body Gasket	PTFE
19	Hex Bolting	A193-B8
20	Actuator	Pneumatic KP / Electric KQ

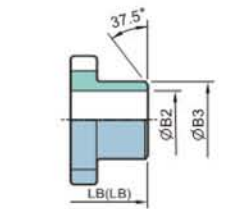
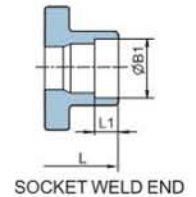
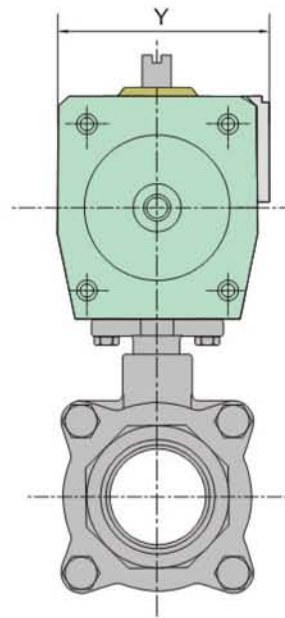
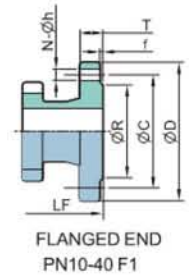
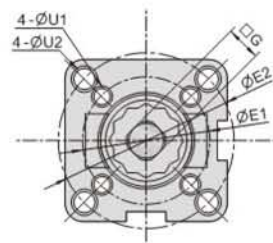
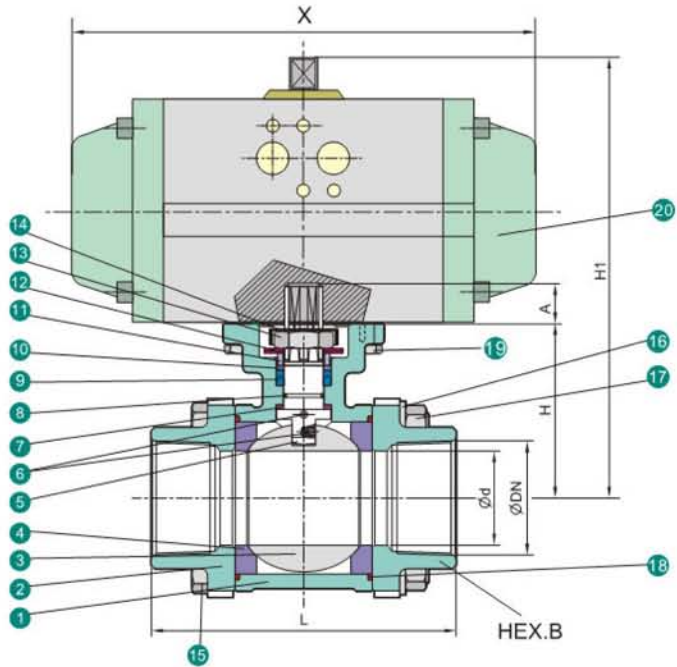

LB (Butt-welding End)  
LE (Extended Butt-welding End)

Unit: mm

SIZE	φd	L	LB	LE	LF	H	H1	φE1	φE2	G	φU1	φU2	A	φD	φC	φR	T	f	N	φh	L1	φB1	φB2	φB3	X	Y	P-Actuator	E-Actuator	Pressure
1/4"	10.6	75	72	165	—	42.0	—	36	42	9	6	6	9	—	—	—	—	—	—	—	10	14.2	10.6	18	142	72	KP50	KQ006	80PSI
3/8"	12.7	75	72	165	—	42.0	—	36	42	9	6	6	9	—	—	—	—	—	—	—	10	17.8	12.7	18	142	72	KP50	KQ006	80PSI
1/2"	15.0	75	75	165	130	42.0	169	36	42	9	6	6	9	95	65	45	16	2	4	14	10	21.8	15.8	22	142	72	KP50	KQ006	80PSI
3/4"	20.0	80	90	190	150	48.5	177	36	50	9	6	7	9	105	75	58	18	2	4	14	13	27.3	20.9	28	142	72	KP50	KQ006	80PSI
1"	25.0	90	100	216	160	58.5	200	42	50	11	6	7	11	115	85	68	18	2	4	14	13	34.0	26.7	34	162	84	KP63	KQ006	80PSI
1-1/4"	32.0	110	110	229	180	63.0	215	42	70	11	6	9	11	140	100	78	18	2	4	18	16	42.8	35.1	43	162	84	KP63	KQ006	80PSI
1-1/2"	38.0	120	125	241	200	71.3	234	50	70	14	7	9	14	150	110	88	18	3	4	18	16	48.9	40.9	50	208	96	KP75	KQ008	80PSI
2"	50.0	140	150	292	230	78.2	241	50	70	14	7	9	14	165	125	102	20	3	4	18	17	61.4	52.5	61	208	96	KP75	KQ008	80PSI
2-1/2"	63.5	185	190	330	290	100.0	291	70	102	17	9	11	17	185	145	122	22	3	8	18	17	74.0	62.7	76	246	108	KP88	KQ015	80PSI
3"	76.0	205	220	356	310	108.5	313	70	102	17	9	11	17	200	160	138	24	3	8	18	17	90.0	78.0	92	266	123	KP100	KQ015	80PSI
4"	100.0	240	270	432	350	140.0	400	—	102	22	—	11	22	235	190	162	24	3	8	22	20	115.4	102.4	115	347	151	KP125	KQ020	80PSI