

# ANGLE BRACKET



- |  |   |
|--|---|
| 1. Product type identification code  | Angle connector<br>Dimensions: see ETA-08/0214  |
| 2. Type, batch, series numbers or other identification code  | ETA-08/0214<br>Batch number: see label  |
| 3. Intended use  | Fasteners for supporting wooden structures, as well as for the fastening of beams and purlins in accordance with ETA-08/0214  |
| 4. Manufacturer contact address  | BB Stanz- und Umformtechnik GmbH<br>Nordhäuser Str. 44<br>06536 Berga<br>Germany  |
| 5. System of systems for durability assessment and testing   | System 2+   |
| 6. Reference document  | ETA-08/0214   |
| 7. Eota ref. / number  | ETA-Danmark A/S, Nordhavn   |
| 8. Conducted by the certification authority  | - Initial inspection of the manufacturing plant and of factory production control<br>- Current monitoring, analysis and assessment of factory production control<br>- Result in conformity certificate<br>0769-CPD-6016 |
| 9. Declared performance  | See ETA-08/0214   |
| 10. Product performance pursuant to item 1 and 2 corresponds to the declared performance pursuant to item 9. The manufacturer pursuant to item 4 is liable for this Performance Declaration. |   |

Signed for the manufacturer and on behalf of the manufacturer by:

Fredrik Toth

Thomé Gruppen AB

Bjurögatan 28, Box 50304, SE-202 13 Malmö, Sweden

Phone: +46 40 38 60 00, Fax: +46 40 18 57 80,

E-mail: [info@fast-fastening.com](mailto:info@fast-fastening.com), [www.fast-fastening.com](http://www.fast-fastening.com)



ETA-Danmark A/S  
Göteborg Plads 1  
DK-2150 Nordhavn  
Tel. +45 72 24 59 00  
Fax +45 72 24 59 04  
Internet [www.etadanmark.dk](http://www.etadanmark.dk)

Authorised and notified according  
to Article 29 of the Regulation (EU)  
No 305/2011 of the European  
Parliament and of the Council of 9  
March 2011

MEMBER OF EOTA



## European Technical Assessment ETA-08/0214 of 04/09/2015

### I General Part

**Technical Assessment Body issuing the ETA and designated according to Article 29 of the Regulation (EU) No 305/2011: ETA-Danmark A/S**

**Trade name of the construction product:**

BB Angle Bracket type KR 95, KR 135, KR 137 and KR 285

**Product family to which the above construction product belongs:**

Three-dimensional nailing plate (Angle brackets for timber-to-timber, timber-to-steel or timber-to-concrete connections)

**Manufacturer:**

BB Stanz- und Umformtechnik  
Nordhäuser Str. 42  
D-06536 Berga  
Tel. +49 34651 2988 0  
Fax +49 34651 2988 20  
Internet [www.bb-berga.de](http://www.bb-berga.de)

**Manufacturing plant:**

BB Stanz- und Umformtechnik  
Nordhäuser Str. 42  
D-06536 Berga

**This European Technical Assessment contains:**

21 pages including 2 annexes which form an integral part of the document

**This European Technical Assessment is issued in accordance with Regulation (EU) No 305/2011, on the basis of:**

Guideline for European Technical Approval (ETAG) No. 015 Three Dimensional Nailing Plates, April 2013, used as European Assessment Document (EAD).

**This version replaces:**

The previous ETA with the same number issued on 2013-06-19 and expiry on 2018-06-19

Translations of this European Technical Assessment in other languages shall fully correspond to the original issued document and should be identified as such.

Communication of this European Technical Assessment, including transmission by electronic means, shall be in full (excepted the confidential Annex(es) referred to above). However, partial reproduction may be made, with the written consent of the issuing Technical Assessment Body. Any partial reproduction has to be identified as such.

## II SPECIFIC PART OF THE EUROPEAN TECHNICAL ASSESSMENT

### 1 Technical description of product and intended use

#### Technical description of the product

Angle Brackets Type KR 95, 135, 137 and 285 are one-piece non-welded, face-fixed angle brackets to be used in timber to concrete and timber to steel connections. They are connected to the timber elements by ringed shank nails or screws and to the concrete and steel elements by bolts.

The angle brackets are made from steel DD 11 according to EN 10111 with a minimum yield strength of  $R_{el} \geq 251 \text{ N/mm}^2$ . Dimensions and hole are shown in Annex A. The angle brackets are made from steel with tolerances according to EN 10143.

### 2 Specification of the intended use in accordance with the applicable EAD

The angle brackets are intended for use in making connections in load bearing structures, as a connection between a timber component and a concrete or steel component, where requirements for mechanical resistance and stability and safety in use in the sense of the Basic Works Requirements 1 and 4 of Regulation (EU) 305/2011 shall be fulfilled.

The connection may be with a single angle bracket or with an angle bracket on each side of the fastened timber member (see Annex B).

The static and kinematic behaviour of the timber members or the supports shall be as described in Annex B.

The wood members can be of solid timber, glued laminated timber and similar glued members, or wood-based structural members with a characteristic density from  $290 \text{ kg/m}^3$  to  $420 \text{ kg/m}^3$ . This requirement to the material of the wood members can be fulfilled by using the following materials:

- Structural solid timber classified to C24-C40 according to EN 338 / EN 14081,
- Glulam classified to GL24-GL36 according to EN 1194 / EN 14080,
- LVL according to EN 14374,
- Parallam PSL,

- Intrallam LSL,
- Glued solid timber according to EN 14080,
- Cross laminated timber,
- Plywood according to EN 636

Annex B states the load-carrying capacities of the angle bracket connections for a characteristic density of  $350 \text{ kg/m}^3$ . For timber or wood based material with a lower characteristic density than  $350 \text{ kg/m}^3$  the load-carrying capacities shall be reduced by the  $k_{\text{dens}}$  factor:

$$k_{\text{dens}} = \left( \frac{\rho_k}{350} \right)^2$$

Where  $\rho_k$  is the characteristic density of the timber in  $\text{kg/m}^3$ .

The design of the connections shall be in accordance with Eurocode 5 or a similar national Timber Code. The wood members shall have a thickness which is larger than the penetration depth of the nails into the members.

The angle brackets are primarily for use in timber structures subject to the dry, internal conditions defined by service class 1 and 2 or wet conditions defined by service class 3 of Eurocode 5 and for connections subject to static or quasi-static loading.

The angle brackets can also be used in outdoor timber structures, service class 3, when a corrosion protection in accordance with Euro Code 5 is applied, or when stainless steel with similar or better characteristic yield and ultimate strength is employed.

The scope of the brackets regarding resistance to corrosion shall be defined according to national provisions that apply at the installation site considering environmental conditions.

The provisions made in this European Technical Assessment are based on an assumed intended working life of the connectors of 50 years.

The indications given on the working life cannot be interpreted as a guarantee given by the producer or Assessment Body, but are to be regarded only as a means for choosing the right products in relation to the expected economically reasonable working life of the works.

### 3 Performance of the product and references to the methods used for its assessment

Characteristic	Assessment of characteristic
<b>3.1 Mechanical resistance and stability*) (BWR1)</b>	
Characteristic load-carrying capacity	See Annex B
Stiffness	No performance determined
Ductility in cyclic testing	No performance determined
<b>3.2 Safety in case of fire (BWR2)</b>	
Reaction to fire	The angle brackets are made from steel classified as Euroclass A1 in accordance with EN 1350-1 and EC decision 96/603/EC, amended by EC Decision 2000/605/EC
<b>3.3 Hygiene, health and the environment (BWR3)</b>	
Influence on air quality	The product does not contain/release dangerous substances specified in TR 034, dated March 2012 0**)
<b>3.7 Sustainable use of natural resources (BWR7)</b>	
	No Performance Determined
<b>3.8 General aspects related to the performance of the product</b>	
	The angle brackets have been assessed as having satisfactory durability and serviceability when used in timber structures using the timber species described in Eurocode 5 and subject to the conditions defined by service class 1 and 2
Identification	See Annex A

\*) See additional information in section 3.8 – 3.9.

\*\*) In addition to the specific clauses relating to dangerous substances contained in this European technical Assessment, there may be other requirements applicable to the products falling within its scope (e.g. transposed European legislation and national laws, regulations and administrative provisions). In order to meet the provisions of the Construction Products Regulation, these requirements need also to be complied with, when and where they apply.

### 3.9 Methods of verification

The characteristic load-carrying capacities are based on the characteristic values of the connectors and the steel plates.

According to EN 1990 (Eurocode – Basis of design) paragraph 6.3.5 the design value of load-carrying capacity can be determined by reducing the characteristic values of the load-carrying capacity with different partial factors.

Therefore, to obtain design values according to the Eurocodes or appropriate national codes of practice, the capacities have to be multiplied with different partial factors for the material properties and – for the connectors mounted in wood – also the coefficient  $k_{mod}$  that takes into account the load duration class.

Thus, the characteristic values of the load-carrying capacity are determined also for timber failure  $F_{Rk,H}$  (obtaining the embedment strength of connectors subjected to shear or the withdrawal capacity of the most loaded connector, respectively) as well as for steel plate failure  $F_{Rk,S}$ . The design value of the load-carrying capacity is the smaller value of both load-carrying capacities.

$$F_{Rd} = \min \left\{ \frac{k_{mod} \cdot F_{Rk,H}}{\gamma_{M,H}}; \frac{F_{Rk,S}}{\gamma_{M,S}} \right\}$$

Therefore, for timber failure the load duration class and the service class are included. The different partial factors  $\gamma_M$  for steel or timber, respectively, are also correctly taken into account.

### 3.10 Mechanical resistance and stability

See annex B for the characteristic load-carrying capacity in the different directions  $F_1$  to  $F_7$ .

The characteristic capacities of the angle brackets are determined by calculation assisted by testing as described in the EOTA Guideline 015 clause 5.1.2. They should be used for designs in accordance with Eurocode 5 or a similar national Timber Code.

No performance has been determined in relation to ductility of a joint under cyclic testing. The contribution to the performance of structures in seismic zones, therefore, has not been assessed.

No performance has been determined in relation to the joint's stiffness properties - to be used for the analysis of the serviceability limit state.

### 3.11 Aspects related to the performance of the product

#### 3.11.1 Corrosion protection in service class 1 and 2.

In accordance with ETAG 015 the angle brackets are made from steel DD 11 according to EN 10111 with a minimum yield strength of  $R_{el} \geq 251 \text{ N/mm}^2$ .

### 3.12 General aspects related to the fitness for use of the product

BB KR angle brackets are manufactured in accordance with the provisions of this European Technical Assessment using the manufacturing processes as identified in the inspection of the plant by the notified inspection body and laid down in the technical documentation.

The nailing pattern used shall be either the maximum or the minimum pattern as defined in Annex B.

The following provisions concerning installation apply:

There shall be nails or screws in all holes or at least in holes as specified on technical drawings in accordance with this document.

All minimum spacing's and edge/end distances in accordance with Eurocode 5 or an appropriate national code shall be complied with.

The angle bracket connection shall be designed in accordance with Eurocode 5 or an appropriate national code.

The cross section of the connected wooden elements shall have a plane surface against the whole angle bracket.

Nails or screws to be used shall have a diameter which fits the holes of the angle brackets.

The structural members – the components 1 and 2 - to which the brackets are fixed shall be:

- Restrained against rotation. At a load  $F_2/F_3$  and  $F_4/F_5$ , the timber component is allowed to be restrained against rotation by the Angle brackets
- Strength class C14 or better, see section 1 of this ETA
- Free from wane under the bracket.
- The actual end bearing capacity of the timber member to be used in conjunction with the bracket is checked by the designer of the structure to ensure it is not less than the bracket capacity and, if

necessary, the bracket capacity reduced accordingly.

- The gap between the timber members does not exceed 3 mm.
- There are no specific requirements relating to preparation of the timber members.
- The execution of the connection shall be in accordance with the assessment holder's technical literature.

## **4 Attestation and verification of constancy of performance (AVCP)**

### **4.1 AVCP system**

According to the decision 97/638/EC of the European Commission<sup>1</sup>, as amended, the system(s) of assessment and verification of constancy of performance (see Annex V to Regulation (EU) No 305/2011) is 2+.

## **5 Technical details necessary for the implementation of the AVCP system, as foreseen in the applicable EAD**

Technical details necessary for the implementation of the AVCP system are laid down in the control plan deposited at ETA-Danmark

Issued in Copenhagen on 2015-09-04 by

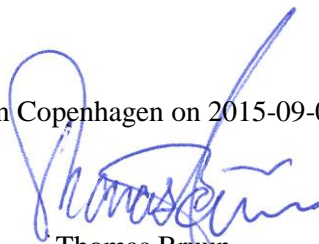

Thomas Bruun  
Managing Director, ETA-Danmark



**Annex A**  
**Product details definitions**

Table A.1 Materials specification

Bracket type	Thickness (mm)	Steel specification	Coating specification
<b>KR 95</b>	4,0	DD 11	55µm according to EN 1461 or galvanic zinc coating with 8µm
<b>KR 135</b>	4,0	DD 11	
<b>KR 137</b>	4,0	DD 11	
<b>KR 285</b>	4,0	DD 11	

Table A.2 Range of sizes

Bracket type	Height (mm)		Width (mm)	
	Min	max	min	max
<b>KR 95</b>	94	96	64	66
<b>KR 135</b>	134	136	64	66
<b>KR 137</b>	136	138	64	66
<b>KR 285</b>	284	286	64	66

Table A.3 Fastener specification

Fastener	Size (mm)			Type	Finish
	Diameter	Length	Threaded Length		
Threaded nail	4,0 / 4,4	40	30	Ringed shank nail according to EN 14592	Electroplated zinc
Screw	5,0	30	25	Self-tapping screw according to ETA 11/0190	Electroplated zinc
Screw	10,0	60	50	Self-tapping screw according to ETA 11/0190	Electroplated zinc

In the load-carrying-capacities of the connection the capacities for threaded nails calculated from the formulas of Eurocode 5 are used assuming a thick steel plate when calculating the lateral nail load-carrying-capacity.

The characteristic withdrawal capacity of the nails has to be determined by calculation in accordance with EN 1995-1-1:2004, paragraph 8.3.2 (head pull-through is not relevant):

$$F_{ax,Rk} = f_{ax,k} \times d \times t_{pen}$$

Where:

$f_{ax,k}$  Characteristic value of the withdrawal parameter in N/mm<sup>2</sup>

$d$  Nail diameter in mm

$t_{pen}$  Penetration depth of the profiled shank including the nail point in mm,  $t_{pen} \geq 30$  mm

Based on tests by Versuchsanstalt für Stahl, Holz und Steine, University of Karlsruhe, the characteristic value of the withdrawal resistance for the threaded nails can be calculated as:

$$f_{ax,k} = 50 \times 10^{-6} \times \rho_k^2$$

Where:

$\rho_k$  Characteristic density of the timber in kg/m<sup>3</sup>

The shape of the nail directly under the head shall be in the form of a truncated cone with a diameter under the nail head which exceeds the hole diameter.

<b>BOLT or METAL ANCHOR diameter</b>	<b>Correspondent Hole diameter</b>	<b>Bolt or metal anchor type</b>
10.0 mm 12.0 mm	Max. 2 mm. larger than the bolt or anchor diameter	Bolt according to EN 14592, Anchor according to ETA (see specification of the manufacturer)

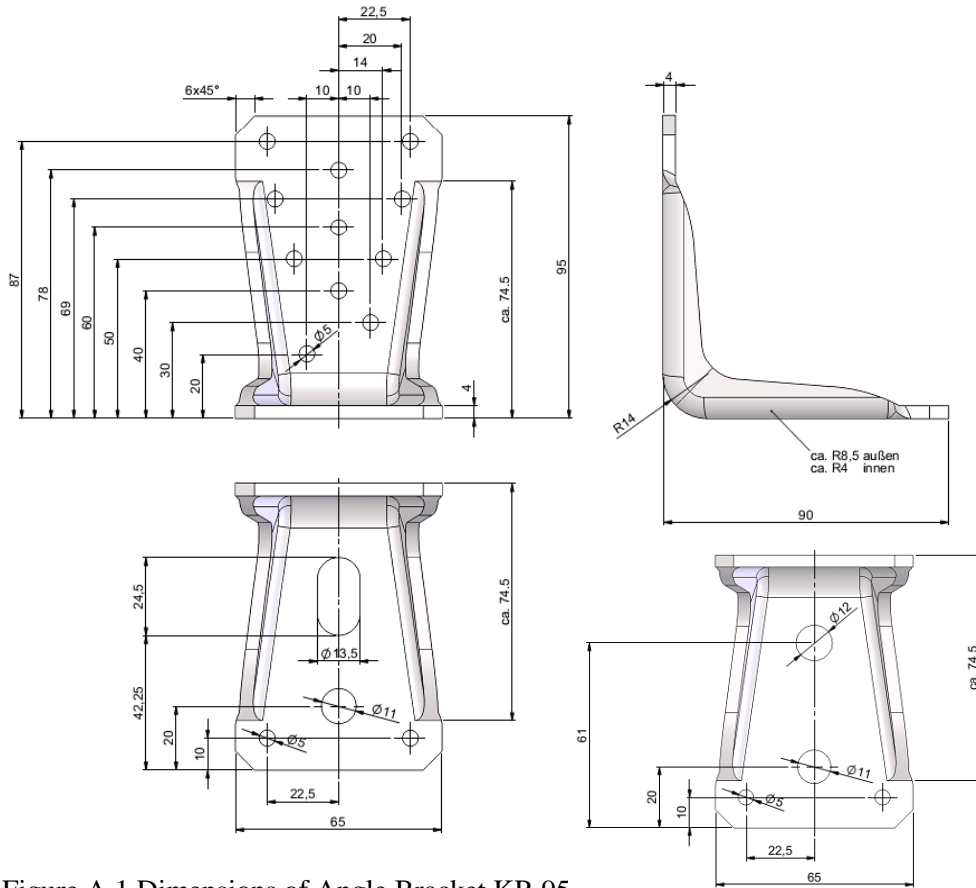

Figure A.1 Dimensions of Angle Bracket KR 95

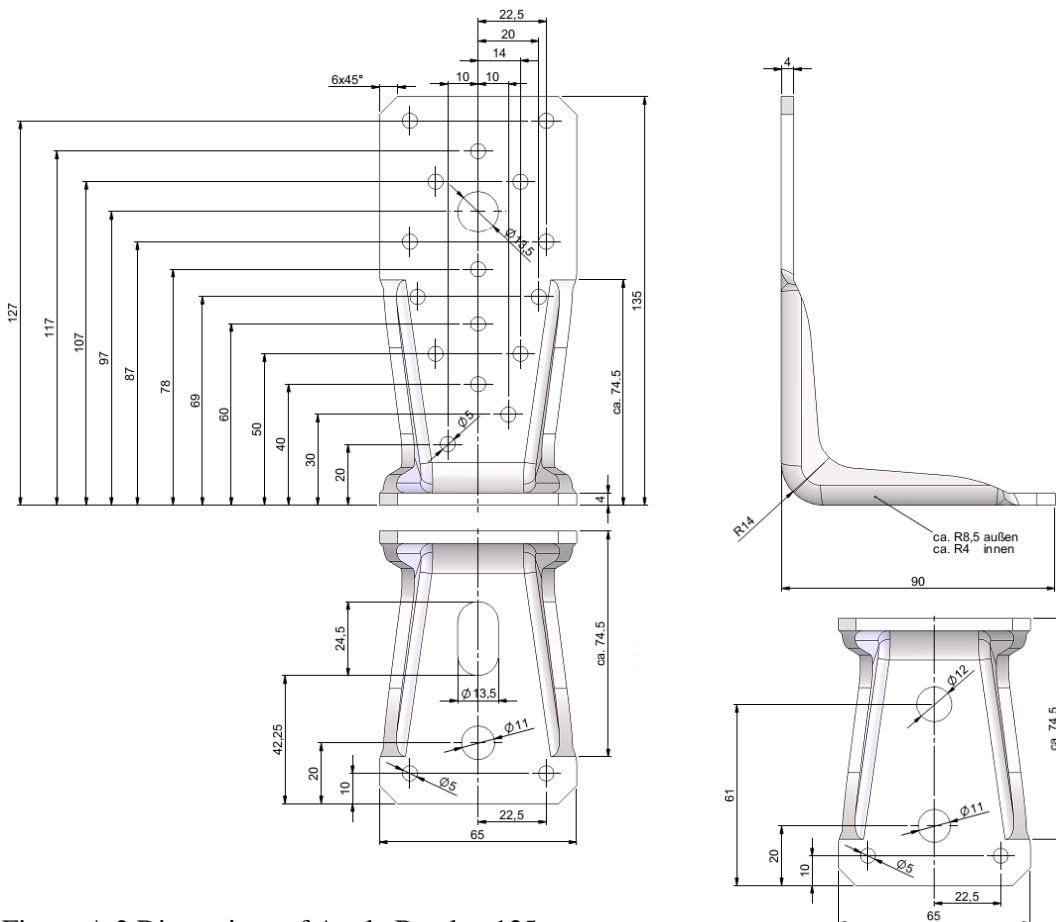

Figure A.2 Dimensions of Angle Bracket 135

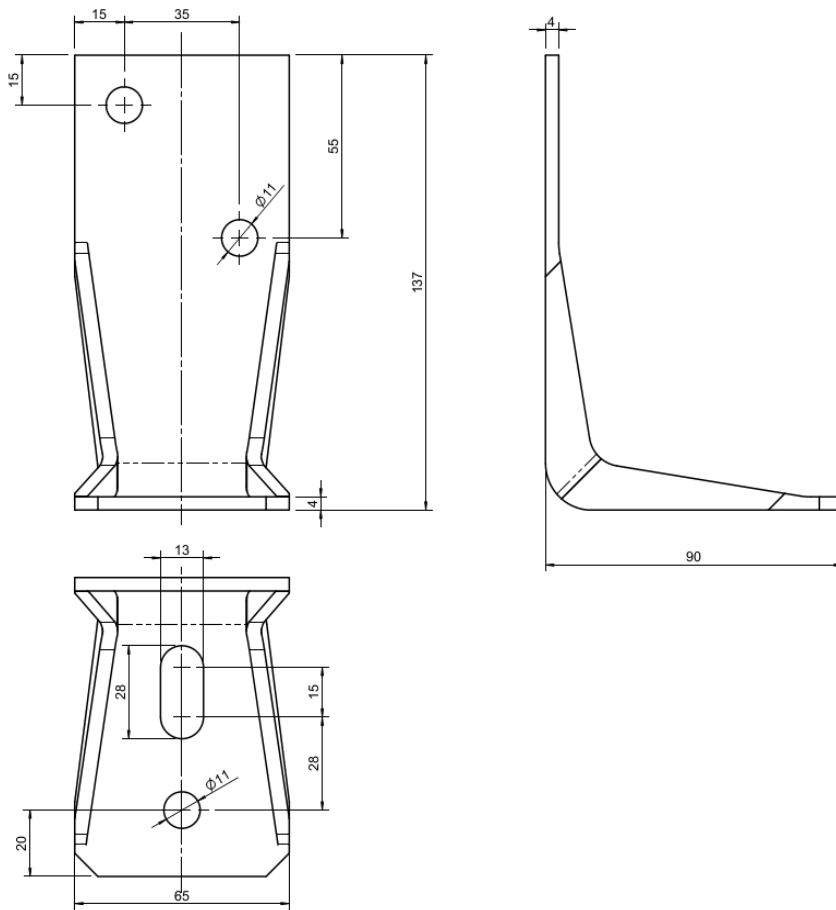

Figure A.3 Dimensions of Angle Bracket KR 137



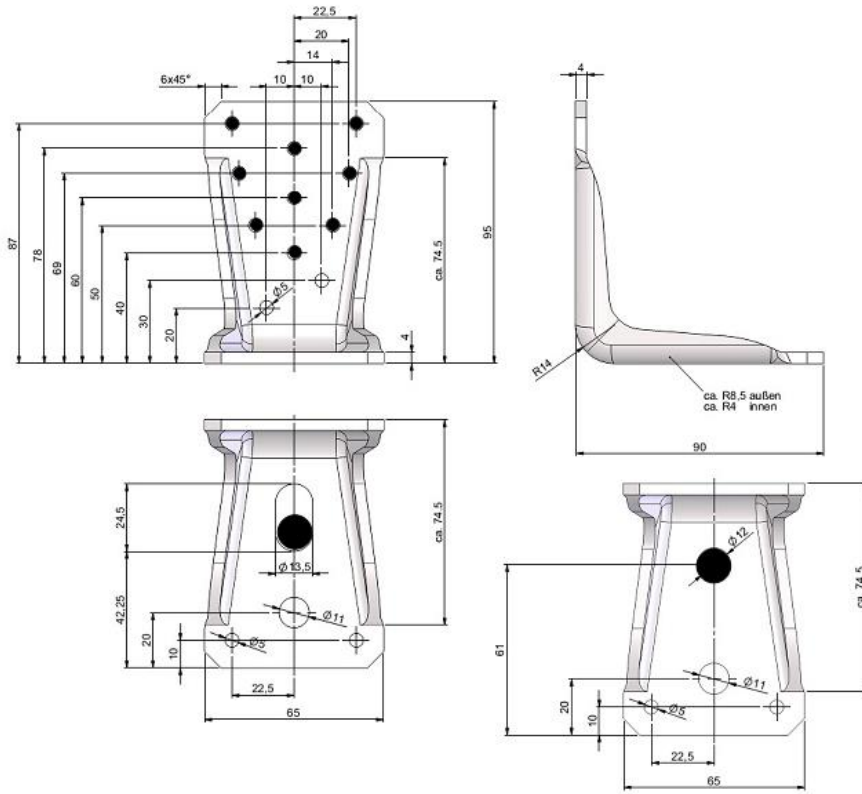

Figure A.5 Nail Patterns of Angle Bracket  
KR 95 – purlin connection

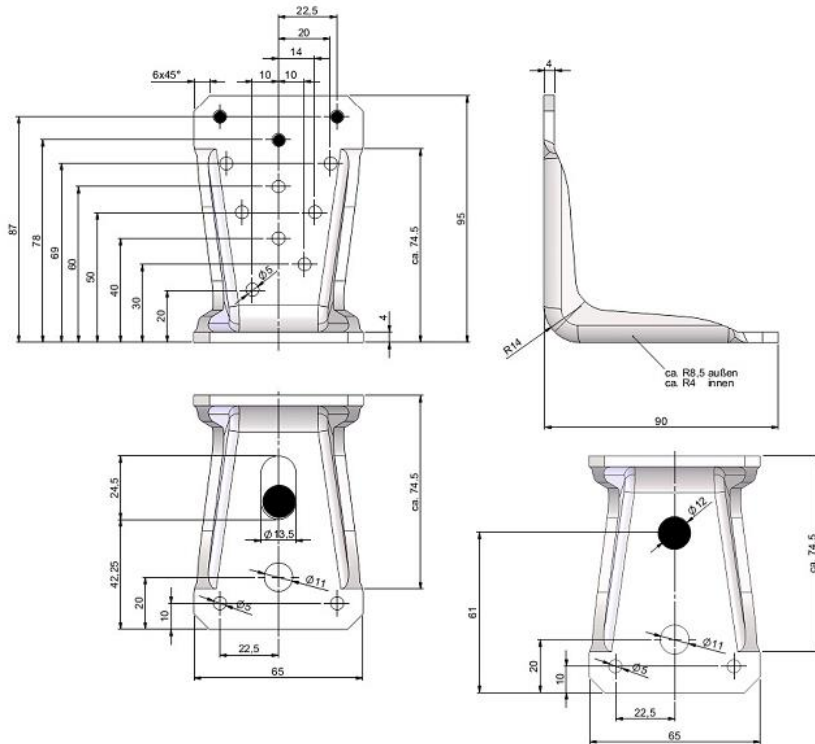

Figure A.6 Nail Patterns of Angle Bracket  
KR 95 – column connection

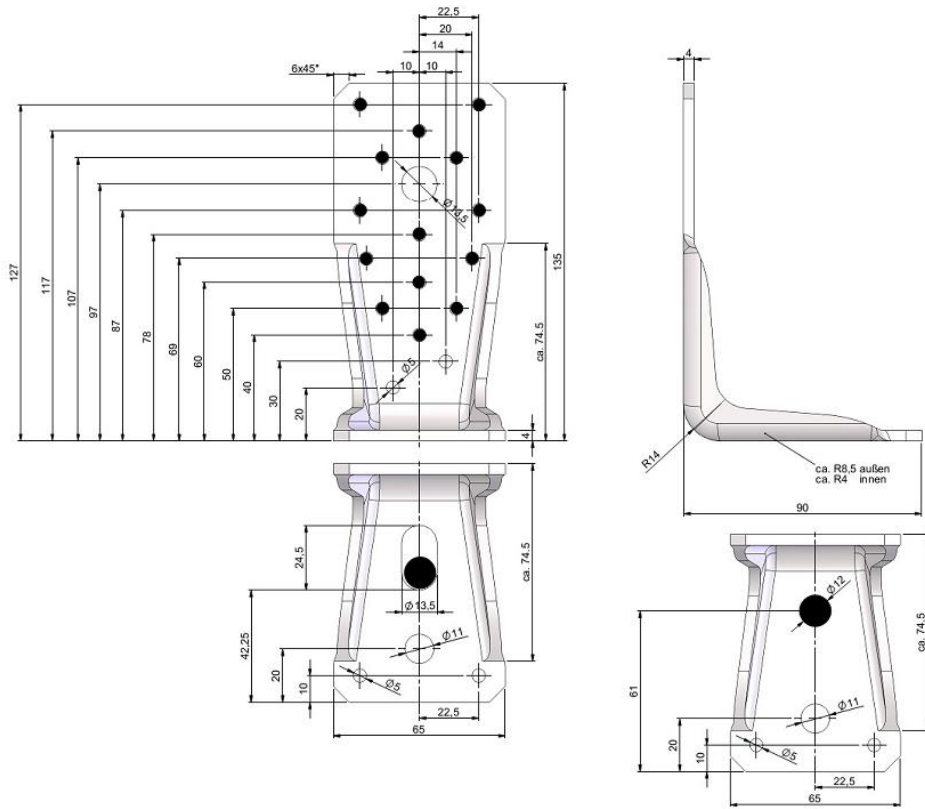

Figure A.7 Nail Patterns of Angle Bracket  
KR 135 - purlin connection

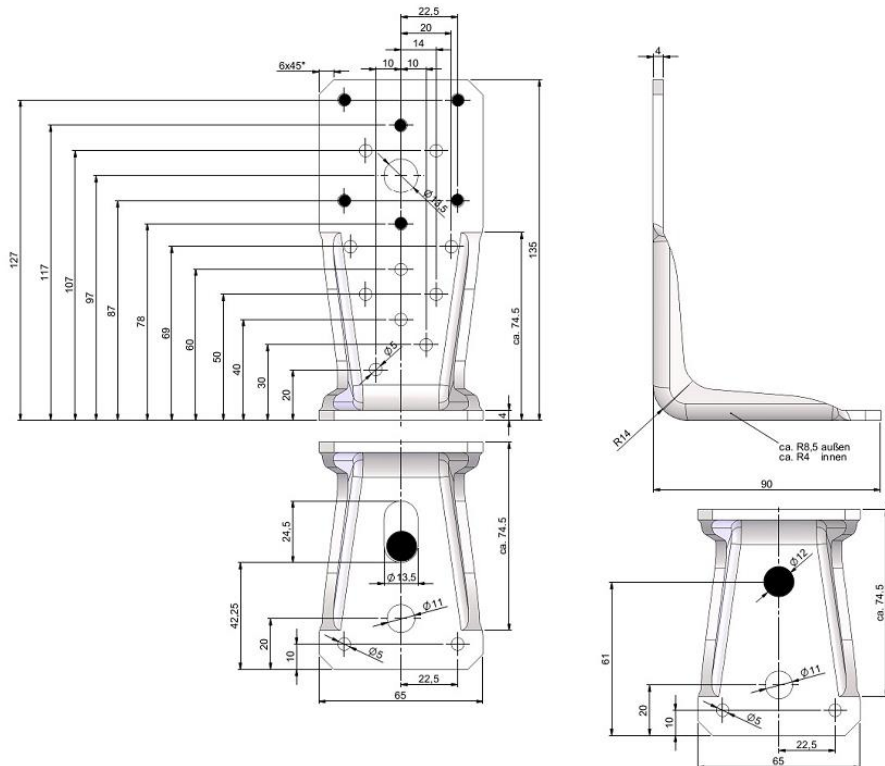

Figure A.8 Nail Patterns of Angle Bracket  
KR 135 - column connection

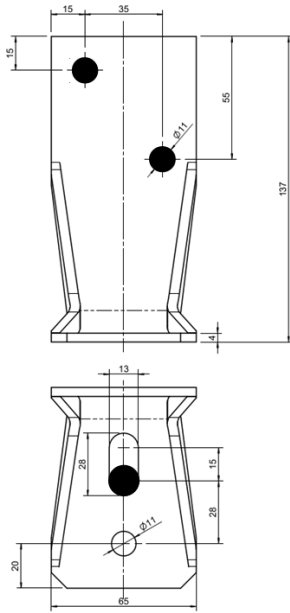

Figure A.9 Nail patterns of Angle Bracket KR 137

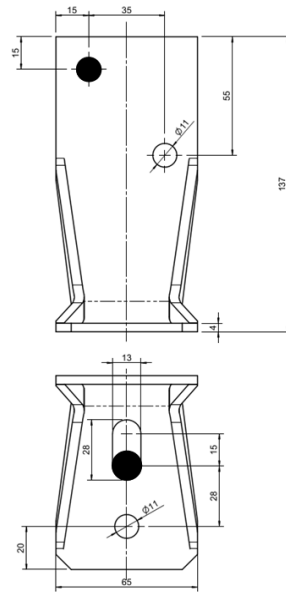

Figure A.10 Nail patterns of Angle Bracket

KR 137

- Purlin -

- Column -

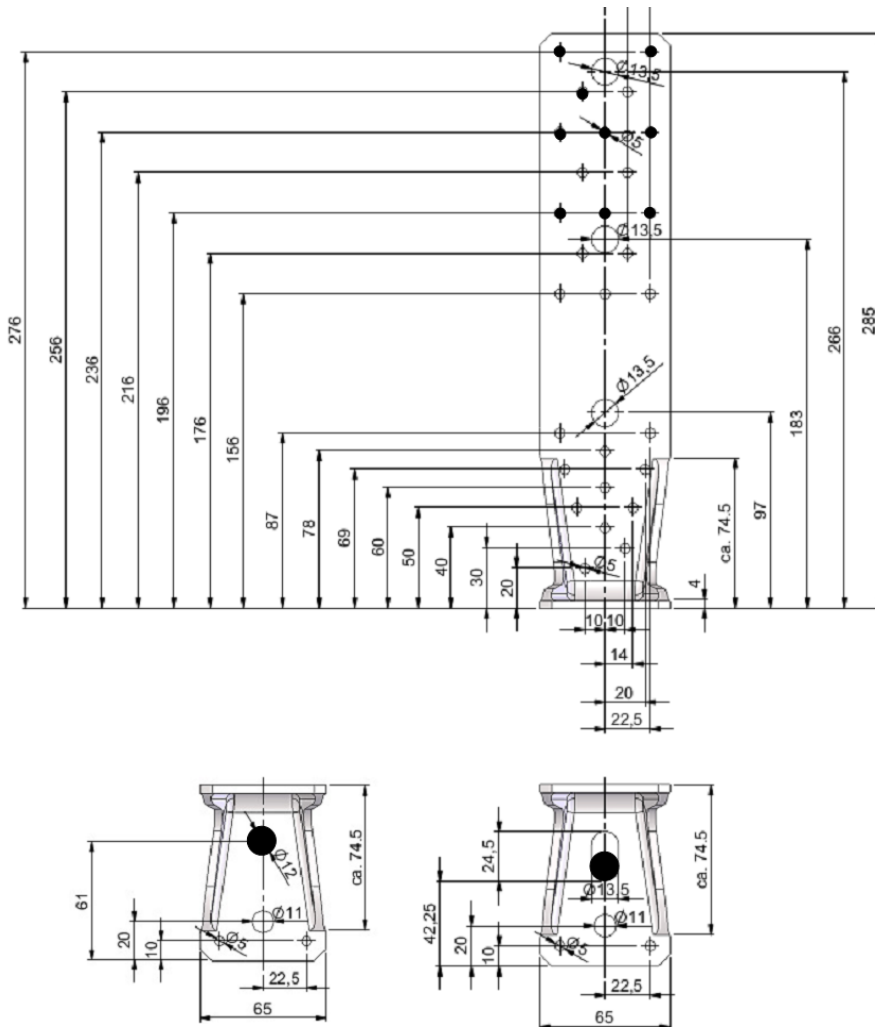

Figure A.11 Nail Patterns of Angle Bracket KR 285 - column connection

## Annex B Characteristic load-carrying capacities

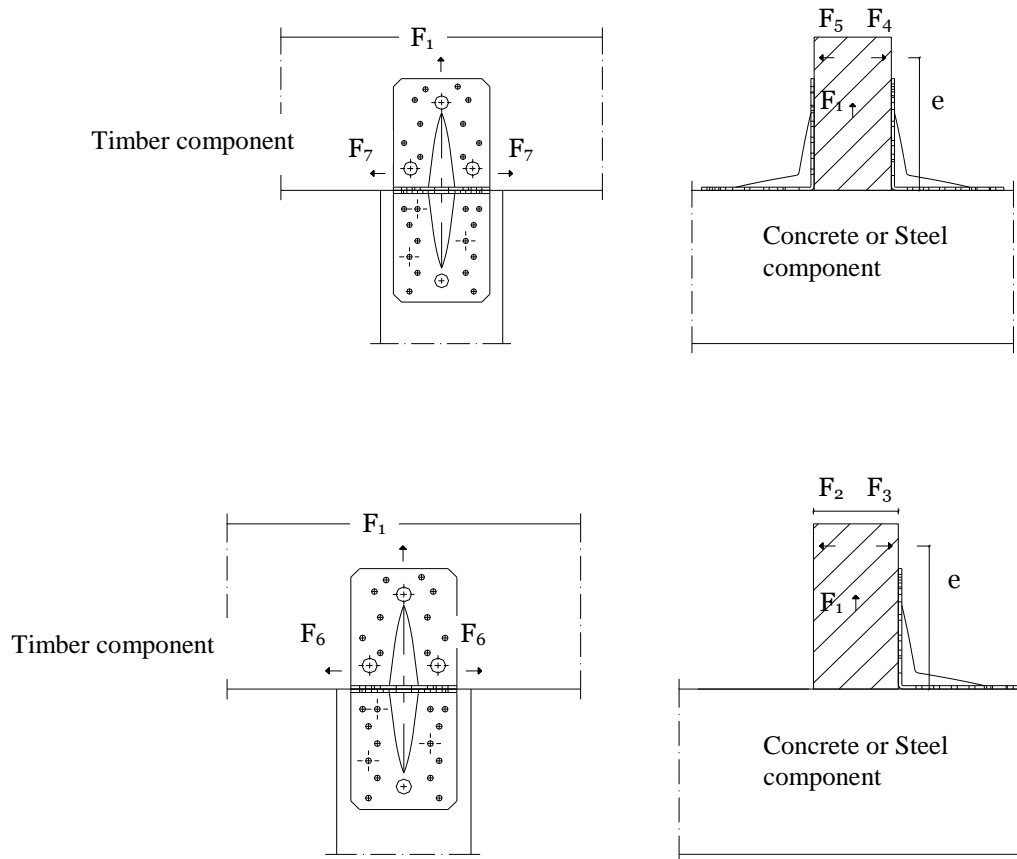

Figure B.1 Definitions of forces, their directions and eccentricity for timber to concrete and timber to steel connections

### Fastener specification

Holes are marked with numbers referring to the nailing pattern in Annex A.

### Double angle brackets per connection

The angle brackets must be placed symmetrically to the component axis.

Acting forces

- $F_1$  Lifting force acting along the central axis of the joint.
- $F_4$  and  $F_5$  Lateral force acting perpendicular to the central axis of timber component. If the load is applied with an eccentricity  $e$ , a design for combined loading is required.
- $F_6$  Lateral force acting in the timber component direction.

### Single angle bracket per connection

Acting forces

- $F_1$  Lifting force acting in the central axis of the angle bracket. The timber component shall be prevented from rotation. If the timber component is prevented from rotation the load-carrying capacity will be half of a connection with double angle brackets.
- $F_2$  and  $F_3$  Lateral force acting perpendicular to the central axis of timber component in the distance  $e$  to the joint.  $F_2$  is the lateral force away from the angle bracket,  $F_3$  is the lateral force towards the angle bracket
- $F_7$  Lateral force acting in the timber component direction. The timber component shall be prevented from rotation. The load-carrying capacity will be half of a connection with double angle brackets.



**Wane**

Wane is not allowed, the timber has to be sharp-edged in the area of the angle brackets.

**Timber splitting**

For the lifting force  $F_1$  it must be checked in accordance with Eurocode 5 or a similar national Timber Code that splitting will not occur.

**Combined forces**

If the forces  $F_1$ ,  $F_2/F_3$  and  $F_7$  act at the same time to a single angle bracket connection, the following inequality shall be fulfilled:

$$\left(\frac{F_{1,d}}{F_{Rd,1}}\right)^2 + \left(\frac{F_{2,d}}{F_{Rd,2}}\right)^2 + \left(\frac{F_{3,d}}{F_{Rd,3}}\right)^2 + \left(\frac{F_{7,d}}{F_{Rd,7}}\right)^2 \leq 1$$

If the forces  $F_1$ ,  $F_4/F_5$  and  $F_6$  act at the same time to a double angle bracket connection, the following inequality shall be fulfilled:

$$\left(\frac{F_{1,d}}{F_{Rd,1}}\right)^2 + \left(\frac{F_{4,d}}{F_{Rd,4}}\right)^2 + \left(\frac{F_{5,d}}{F_{Rd,5}}\right)^2 + \left(\frac{F_{6,d}}{F_{Rd,6}}\right)^2 \leq 1$$

The forces  $F_2$  and  $F_3$  or  $F_4$  and  $F_5$  are forces with opposite direction. Therefore only one force  $F_2$  or  $F_3$ , respectively, and  $F_4$  or  $F_5$ , respectively, is able to act simultaneously with  $F_1$ ,  $F_6$  or  $F_7$ , while the other shall be set to zero.

If the load  $F_4/F_5$  is applied with an eccentricity  $e$ , a design for combined loading for connections with double angle brackets is required. Here, an additional force  $\Delta F_1$  has to be added to the existing force  $F_1$ .

$$\Delta F_{1,d} = F_{4,d} / F_{5,d} \cdot \frac{e}{B}$$

$B$  is the width of the timber component.

### Load-carrying capacities with 1 or 2 angle brackets per connection

**Table B.1:** Characteristic values in the F1a - purlin, 1 angle bracket / connection

Angle Bracket	Number of nails	$F_{1a,k}$ in kN	$k_t$
KR 95	9	13,7	2,85
KR 135	14	21,2	
KR 137	2	10,9	

**Table B.2:** Characteristic values in the F1b - column, 1 angle bracket / connection

Angle Bracket	Number of nails	$F_{1b,k}$ in kN	$k_t$
KR 95	3	4,6	2,85
KR 135	6	9,1	
KR 137	1	2,9	
KR 285	9	13,7	

**Table B.3:** Characteristic values in the F1a - purlin, 2 angle brackets / connection

Angle Bracket	Number of nails	$F_{1a,k}$ in kN	$k_t$
KR 95	9	27,4	1,43
KR 135	14	42,4	
KR 137	2	21,9	

**Table B.4:** Characteristic values in the F1b - column, 2 angle brackets / connection

Angle Bracket	Number of nails	$F_{1b,k}$ in kN	$k_t$
KR 95	3	9,2	1,43
KR 135	6	18,3	
KR 137	1	11,5	
KR 285	9	27,5	

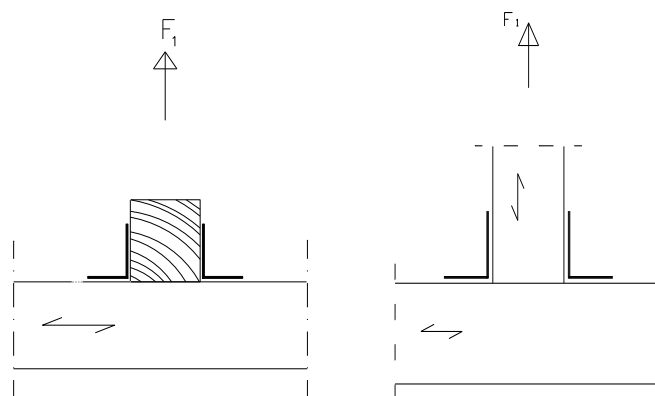

Figure B.2 Load  $F_1$ , purlin (left) and column (right)

**Table B.5:** Characteristic values in the F2 for KR 95, 1 angle bracket / connection

KR 95			
	$F_{2,Rk}$ in kN		
	H in m		
B in m	0,12	0,14	0,18
0,06	4,29	4,58	4,68
0,10	3,72	3,81	3,98
0,14	3,56	3,61	3,70

**Table B.6:** Factor  $k_t$  for angle bracket KR 95 force F2

KR 95			
	$k_t$		
	H in m		
B in m	0,12	0,14	0,18
0,06	2,16	2,24	2,44
0,10	2,05	2,08	2,15
0,14	2,01	2,03	2,07

**Table B.7:** Characteristic values F2 for KR 135, 1 angle bracket / connection

KR 135			
	$F_{2,Rk}$ in kN		
	H in m		
B in m	0,16	0,18	0,22
0,06	4,45	4,94	5,03
0,10	3,91	3,98	4,06
0,14	3,73	3,77	3,83

**Table B.8:** Factor  $k_t$  for angle bracket KR 135 force 2

KR 135			
	$k_t$		
	H in m		
B in m	0,16	0,18	0,22
0,06	1,94	2,82	4,50
0,10	2,02	2,06	2,04
0,14	1,94	1,97	2,02

**Table B.9:** Characteristic values F2 for KR 137, 1 angle bracket / connection

KR 137			
	F <sub>2,Rk</sub> in kN		
	H in m		
B in m	0,16	0,18	0,22
0,06	3,83	3,73	3,95
0,10	3,45	3,55	3,71
0,14	3,71	3,34	3,44

**Table B.10:** Factor k<sub>t</sub> for angle bracket KR 137 force 2

KR 137			
	k <sub>t</sub>		
	H in m		
B in m	0,16	0,18	0,22
0,06	1,70	1,73	2,04
0,10	1,61	1,63	1,65
0,14	1,65	1,59	1,61

**Table B.11:** Characteristic values F3 for KR 95, 1 angle bracket / connection

KR 95		
H in m	F <sub>3,Rk</sub> in kN	
	Steel	Timber
0,12	1,15	2,06
0,14	0,90	1,35
0,18	0,62	0,79

**Table B.12:** Characteristic values F3 for KR 135, 1 angle bracket / connection

KR 135	
H in m	F <sub>3,Rk</sub> in kN
	Steel
0,16	1,24
0,18	0,94
0,22	0,48

**Table B.13:** Characteristic values F3 for KR 137, 1 angle bracket / connection

KR 137	
H in m	F <sub>3,Rk</sub> in kN
	Steel
0,16	0,65
0,18	0,53
0,22	0,38

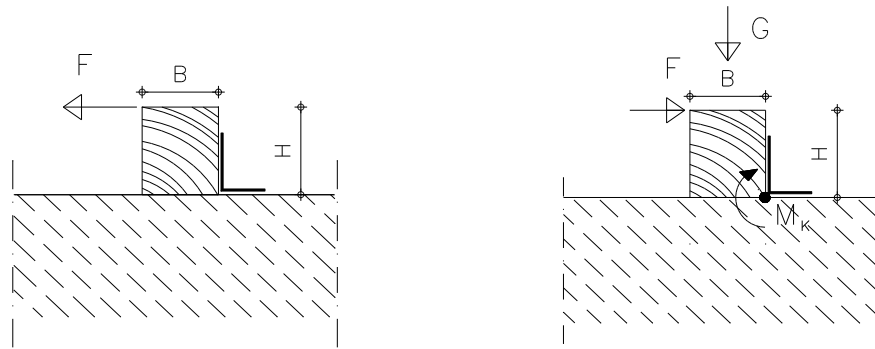

Figure B.3 Load  $F_2$  (left) and Load  $F_3$  (right)

**Table B.14:** Characteristic values for Force  $F_4/F_5$

Angle Bracket	$F_{4/5,Rk}$ in kN
<b>KR 95</b>	7,58
<b>KR 135</b>	7,99
<b>KR 137</b>	8,57

For different purlin widths and depths, the interaction equations were evaluated. The results are given in the tables 15 and 16.

**Table B.15:** Characteristic values  $F_4/F_5$  for KR 95

<b>KR 95</b>			
	$F_{4,5Rk}$ in kN		
	H in m		
B in m	0,12	0,14	0,18
<b>0,06</b>	6,63	6,37	5,83
<b>0,10</b>	7,19	7,07	6,79
<b>0,14</b>	7,38	7,31	7,14

**Table B.16:** Characteristic values  $F_4/F_5$  for KR 135

<b>KR 135</b>			
	$F_{4/5,Rk}$ in kN		
	H in m		
B in m	0,16	0,18	0,22
<b>0,06</b>	7,14	6,96	6,57
<b>0,10</b>	7,65	7,57	7,38
<b>0,14</b>	7,81	7,77	7,66

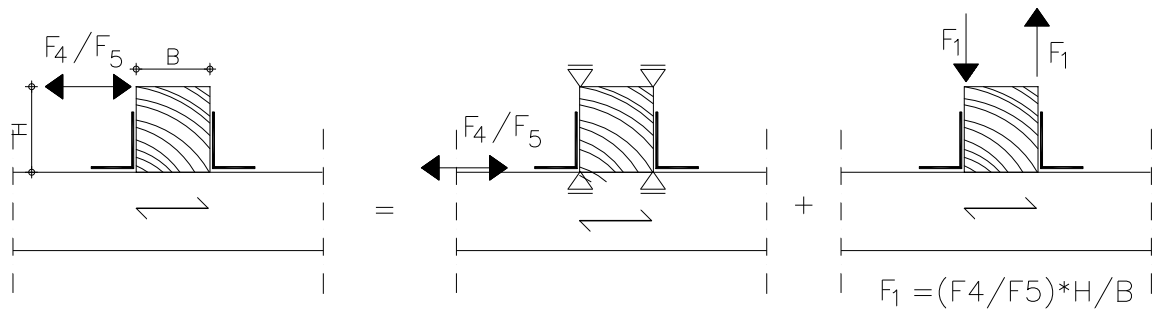

Figure B.4 Load Case  $F_4/F_5$  reduced to two basic load cases

**Table B.17:** Characteristic values  $F_6$  (1 angle bracket / connection) and  $F_7$  (2 angle brackets / connection)

Angle Bracket	$F_{6,Rk}$ in kN	$F_{7,Rk}$ in kN
<b>KR 95</b>	1,72	3,44
<b>KR 135</b>	2,76	5,53
<b>KR 137</b>	2,14	4,28