

# Victaulic® FireLock™ Automatic Sprinklers

⚠ **WARNING**



- Read and understand all instructions before attempting to install any Victaulic products.
- Always verify that the piping system has been completely depressurized and drained immediately prior to installation, removal, adjustment, or maintenance of any Victaulic products.
- Confirm that any equipment, branch lines, or sections of piping that may have been isolated for/ during testing or due to valve closures/positioning are identified, depressurized, and drained immediately prior to installation, removal, adjustment, or maintenance of any Victaulic products.
- Wear safety glasses, hardhat, and foot protection.

Failure to follow these instructions could result in death or serious personal injury and property damage.

- Victaulic® FireLock™ Automatic Sprinklers shall be used only in fire protection systems that are designed and installed in accordance with current, applicable National Fire Protection Association (NFPA 13, 13D, 13R, etc.) standards, or equivalent standards, and in accordance with applicable building and fire codes. These standards and codes contain important information regarding protection of systems from freezing temperatures, corrosion, mechanical damage, etc.
- These installation instructions are intended for an experienced, trained installer. The installer shall understand the use of this product and why it was specified for the particular application.
- The installer shall understand common industry safety standards and potential consequences of improper product installation.

Failure to follow installation requirements and local and national codes and standards could compromise system integrity or cause system failure, resulting in death or serious personal injury and property damage.

## IMPORTANT INSTALLATION INFORMATION

- Victaulic® FireLock™ Automatic Sprinklers shall be installed according to current, applicable Factory Mutual (FM) standards, VdS standards, CEA 4001 standards, National Fire Protection Association (NFPA 13, 13D, 13R, etc.) standards or equivalent standards and in accordance with applicable building and fire codes. Deviations from these standards or alterations to sprinklers (including painting and coating) will void any Victaulic warranty and will impact system integrity. Installations shall meet the provisions of the local authority having jurisdiction and local codes, as applicable, and shall comply with all design specifications.
- Refer to the specific Victaulic product publication for applications and listing information. Product publications can be downloaded at victaulic.com.**
- Transport and store sprinklers in a cool, dry environment in their original packaging. To prevent damage, **DO NOT** empty sprinklers into bags or buckets.
- Size the piping system to meet or exceed the minimum required flow rate for the sprinkler system.
- Per NFPA requirements, flush the system to remove foreign material. Continue to flush the system until water runs clear.
- DO NOT** install sprinkler system piping through heating ducts.
- DO NOT** connect sprinkler system piping to domestic hot water systems.
- DO NOT** allow electrical wiring or other cabling to be hung or wrapped around the sprinkler piping system.
- DO NOT** install sprinklers and sprinkler fittings where ambient conditions may fall below or exceed the maximum listed or approved temperature ratings.
- DO NOT** install sprinklers that have been dropped or struck by another object, even if they do not appear damaged. Never install glass bulb sprinklers if the bulb is cracked or if there is a loss of liquid from the bulb. Discard and replace any sprinklers that are damaged or show signs of corrosion.
- Before installation, verify that the sprinkler is the proper model, orifice size, and temperature rating for the intended application.
- Protect wet piping systems from freezing temperatures.
- To avoid damage, install sprinklers into the fittings only after the sprinkler system piping is in place.

- DO NOT** paint, coat, plate, or alter sprinklers. Sprinklers that have been altered from their manufactured condition may not function properly and will void any agency listings and/or approvals and impact system integrity.
- DO NOT** test sprinklers with a heat source. The glass bulb can weaken or shatter if exposed to a heat source during testing.
- DO NOT** clean sprinklers with soapy water, detergents, ammonia, cleaning fluids, or other chemicals. Remove any dust, lint, etc. with a soft, dry cloth.
- Sprinklers that have operated **SHALL NOT** be reassembled or reused. When replacing sprinklers, use new sprinklers of the same type, orifice, temperature, and response.
- Inspect sprinklers on a regular basis for corrosion, mechanical damage, obstructions, etc. The frequency of inspections may vary due to corrosive atmospheres/water supplies and activities around the sprinklers.
- DO NOT** hang anything from or attach anything to sprinklers. Obstructing the discharge pattern will affect the sprinkler's performance in the event of a fire.
- If construction is altered, the building owner or their representative is responsible for referencing applicable standards to determine if additional sprinklers or other system adjustments are required.
- The building owner or their representative is responsible for maintaining the fire protection system in proper operating condition.
- After installation is complete, the entire sprinkler system shall be tested in accordance with applicable standards (NFPA 13, NFPA 25, etc.) that describe the care and maintenance of sprinkler systems. In addition, the authority having jurisdiction may have additional maintenance, testing, and inspection requirements that shall be followed. **NOTE:** A successful test is not a substitute for proper system installation and maintenance.

⚠ **WARNING**

- Replacement/relocation of Victaulic® FireLock™ Automatic Sprinklers SHALL be performed by qualified personnel familiar with the system's original design criteria, sprinkler listings/ approvals, and state and local codes (including NFPA 13 standards).**

Failure to follow this instruction could affect system performance during a fire, resulting in death or serious personal injury and property damage.

## STANDARD SPRINKLER INSTALLATION

Each Victaulic® FireLock™ Automatic Sprinkler is shipped with a bulb protector, which protects the glass bulb from damage during shipment and installation. Bulb protectors shall remain installed until the sprinkler system is ready to be placed into service, or as instructed in step 6 on this page.

1. Inspect the sprinkler for any signs of physical damage and the glass bulb for cracks and loss of fluid. **DO NOT** install a sprinkler that has been dropped or damaged during handling.

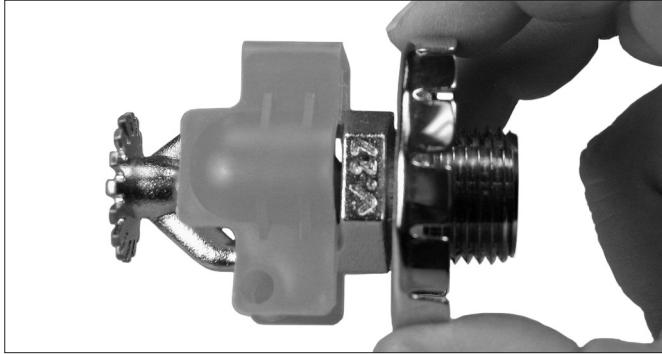

2. **FOR RECESSED PRODUCT:** Install the collar onto the sprinkler. Verify that the collar is tightened completely up against the wrench boss, as shown above.
3. Apply two to three wraps of tape or a non-hardening pipe-joint compound to the male threads only.

### WARNING

- **DO NOT** allow sealing material to enter the sprinkler's orifice or to contact the bulb or seal.
- **DO NOT** handle sprinklers by the deflector.
- **DO NOT** exceed the specified assembly torques.
- Verify that the sprinkler wrench engages **ONLY** the wrench boss of the sprinkler and not the frame, deflector, or bulb.

Failure to follow these instructions could cause improper sprinkler operation, resulting in death or serious personal injury and property damage.

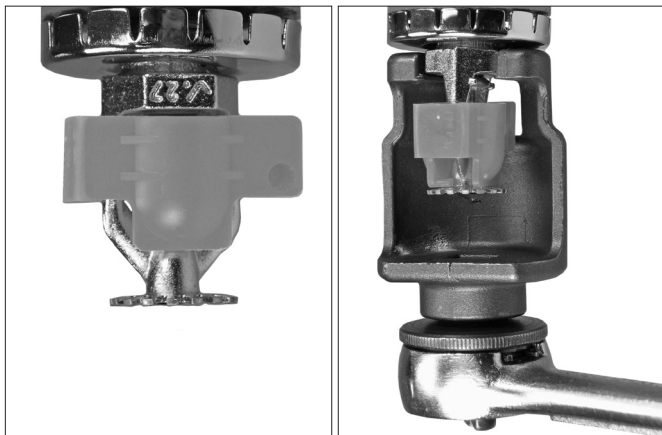

4. Install the sprinkler in its intended orientation only. Thread the sprinkler into the fitting by hand, then tighten the sprinkler into the fitting by using the proper model sprinkler wrench (refer to the "Available Sprinkler Wrenches" table). Verify that the sprinkler wrench engages **ONLY** the wrench boss of the sprinkler. **DO NOT** engage the sprinkler wrench on the frame, deflector, or bulb. To obtain a proper seal, tighten the sprinkler securely to prevent leakage. **DO NOT** exceed the maximum assembly torque values listed in the "Maximum Assembly Torque Values" table.

5. **FOR RECESSED PRODUCT:** Install the escutcheon by centering it over the sprinkler. Push the escutcheon onto the recess collar until it contacts the ceiling.

### WARNING

- Sprinklers cannot operate properly with bulb protectors in place.
  - Bulb protectors shall be removed from all sprinklers before the sprinkler system is placed into service.
  - **DO NOT** use any tools to remove bulb protectors.
- Failure to follow these instructions will cause improper sprinkler operation, resulting in death or serious personal injury and property damage.

6. Remove the bulb protector from all sprinklers carefully by hand before the sprinkler system is placed into service. **NOTE:** Bulb protectors on all upright sprinklers, or on any sprinklers installed more than 10 feet/3 meters above the floor, can be removed immediately following installation.

### MAXIMUM ASSEMBLY TORQUE VALUES

Orifice Size	Maximum Torque ft-lbs/N•m	Orifice Size	Maximum Torque ft-lbs/N•m
½-inch NPT	14 19	1-inch NPT	30 41
¾-inch NPT	20 27		

### AVAILABLE SPRINKLER WRENCHES

Frame Style	Sprinkler Wrench Style/Sprinkler Wrench Model			
	Open End	Recessed	Concealed	Tee-Handle
V28/V42/V56	½-inch	½-inch	–	–
V11/V81	¾-inch	¾-inch	–	–
V25/V27	V27	V27-2	V39	–
V29	–	–	V29-2	V29-1
V31/V33	–	–	V31/V33	–
V34/V40	V34/V40	V34/V40	–	–
V36	V36	V36	V36	–
V38	–	–	V38-4	V38-5
V44/V47	V44/V47	–	–	–
V46/V48	V46	–	–	–
V49 ESFR	V49	–	–	–
V49/V56/V81 "Inch"	–	–	1-inch	–
V10	Use any commercially available wrench			

### HOLE SIZES FOR ESCUTCHEONS

Escutcheon Style(s)	Hole Sizes for Escutcheons inches/millimeters	
	Minimum	Maximum
Semi-Recessed	2 51	2 ¾ 60
V27 Concealed	2 ¾ 60	2 13/16 71
V29 Flush Pendant	1 ⅝ 41	2 51
V31/V33/V35 Concealed	2 ⅝ 67	2 ¾ 70
V36/V40 Plain, Extended, and Flush	1 ½ 38	2 ½ 63
V36/V40 Sleeve/Skirt	1 ¾ 44	2 ½ 63
V38 Concealed	2 ¾ 60	2 11/16 68
V56/V81 "Inch" Concealed*	2 ¼ 57	2 ½ 63
V49 "Inch" Concealed	2 ¾ 70	2 ⅞ 73

\* Hole size can go up to 3 ⅞ inches/98 mm maximum with seismic cover plate

### DRY SPRINKLER INSTALLATION

- Victaulic FireLock™ Dry Sprinklers shall be installed in accordance with current, applicable NFPA (NFPA 13, 13D, 13R, etc.) standards, or equivalent standards, and in accordance with applicable building and fire codes.
- Apply two to three wraps of tape or a non-hardening pipe-joint compound to the male threads only.
- Install dry sprinklers by using a wrench on the brass inlet fitting. When these installation methods are not possible, the proper sprinkler wrench can be used with extreme care for dry sprinkler lengths up to 18 inches/457 mm.
- **DO NOT** use excessive torque during installation. Excessive torque can distort the sprinkler frame. When a Model V36 Sprinkler Wrench is used with a Model V36 Dry Sprinkler, or when a Model V34 Sprinkler Wrench is used with a Model V40 Dry Sprinkler, do not exceed 30ft-lbs/41 N•m. When a pipe wrench is used on the outer tube, do not exceed 40ft-lbs/54 N•m.

**DRY SYSTEMS:** Dry sprinklers shall be installed only into the outlet of a fitting (excluding elbows) or welded outlet that meets the dimensional requirements of ANSI B16.3 and ANSI B16.4, Class 125 and Class 150. Use a sample fitting to confirm proper engagement and to verify that there is no interference between the sprinkler and fitting. To ensure unobstructed flow during operation, and for applications where systems are subjected to freezing temperatures, the dry sprinkler shall be installed into a fitting that will prevent condensation from accumulating above the seal.

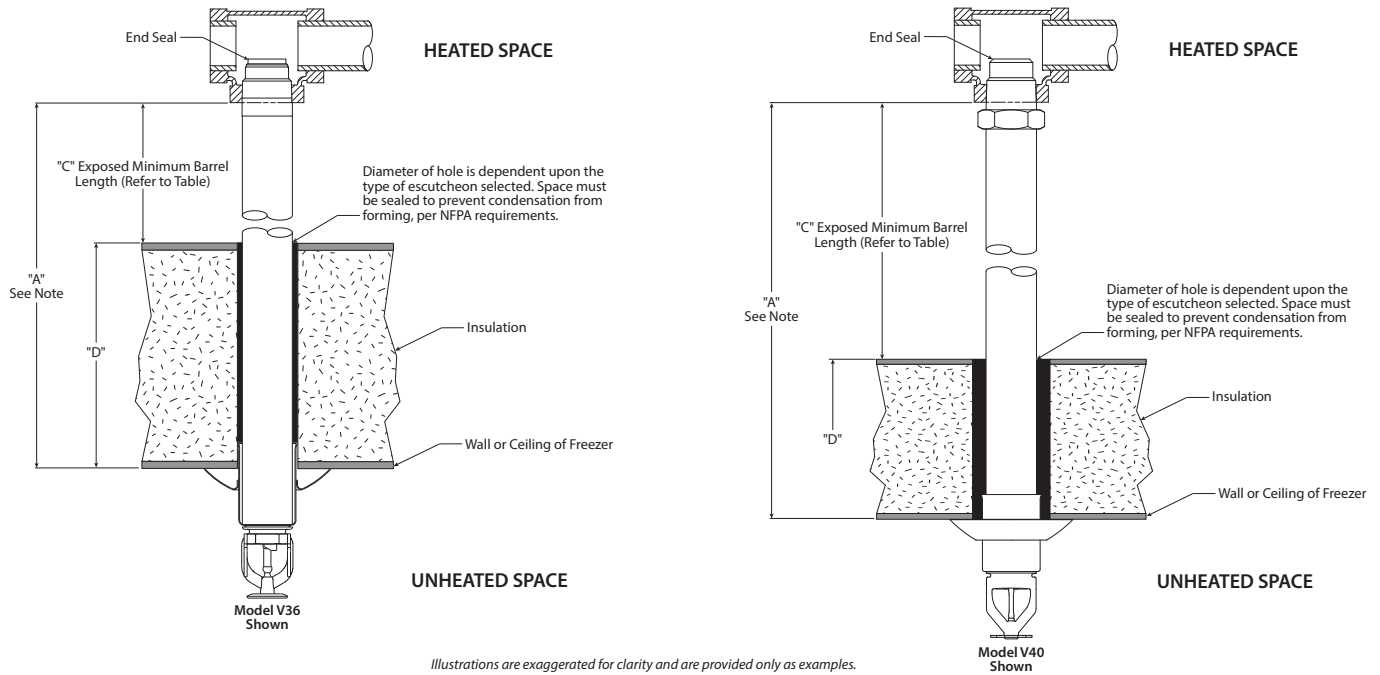

**NOTE:** The “A” dimension of a dry sprinkler, which extends into a freezer from a wet piping system, shall take into account the wall or ceiling thickness of the freezer. The minimum length of the dry sprinkler should not be less than the lengths specified in the table to the right, plus the thickness of the freezer’s wall or ceiling (“A” = “C” + “D”).

Refer to the drawing above for a representation of the “A” dimension.

**DO NOT** attempt to modify dry sprinklers, since they are manufactured to this specific “A” dimension.

**WET SYSTEMS:** The inlet of the dry sprinkler **SHALL NOT** bottom out in the fitting. **DO NOT** install dry sprinklers into any threaded elbow, thread-by-thread coupling, or fitting that interferes with thread penetration. Dry sprinklers can be installed into the outlets of Style 920/Style 920N Mechanical-T Bolted Branch Outlets, Style 922 FireLock™ Outlet-T products, and No. 141 IGS™ Grooved x Female Threaded Adapter Nipples. Dry Sprinklers can be installed into CPVC fittings (excluding elbows) that do not interfere with thread penetration. Use a sample fitting to confirm proper engagement. Verify that the exposed minimum barrel length in the heated space is measured and maintained in accordance with the table to the right.

Where wet systems incorporate IGS grooves for sprinkler connection, the Style V9 Victaulic® FireLock™ IGS™ Installation-Ready™ Sprinkler Coupling shall be used.

The table to the right is used when the ambient temperature is maintained between 40°F/4°C and 60°F/16°C around the wet piping system.

**EXPOSED BARREL AMBIENT TEMPERATURE (°F/°C)**

Ambient Temperature Exposed to Discharge End of Sprinkler °F/°C	“C” – Exposed Minimum Barrel Length inches/mm		
	40°F/4°C	50°F/10°C	60°F/16°C
40	0	0	0
4	0	0	0
30	0	0	0
-1	0	0	0
20	4	0	0
-7	102	0	0
10	8	1	0
-12	203	25	0
0	12	3	0
-18	305	76	0
-10	14	4	1
-23	356	102	25
-20	14	6	3
-29	356	152	76
-30	16	8	4
-34	406	203	102
-40	18	8	4
-40	457	203	102
-50	20	10	6
-46	508	254	152
-60	20	10	6
-51	508	254	152

**NOTE:** Exposed minimum barrel lengths are inclusive up to 30-mph/48-kph wind velocities

# Victaulic® FireLock™ Automatic Sprinklers

## SPRINKLER GUARD INSTALLATION

**WARNING**

- Sprinkler guards shall be installed **AFTER** the sprinkler is installed and before the system is tested.
- Avoid damage to the frame, deflector, and bulb during sprinkler guard installation.

Failure to follow these instructions could cause improper sprinkler operation, resulting in death or serious personal injury and property damage.

**NOTICE**

- The photo below is intended only to show the clarity of guard and sprinkler features. Sprinkler guards shall be installed **AFTER** the sprinkler is installed properly into the fitting.

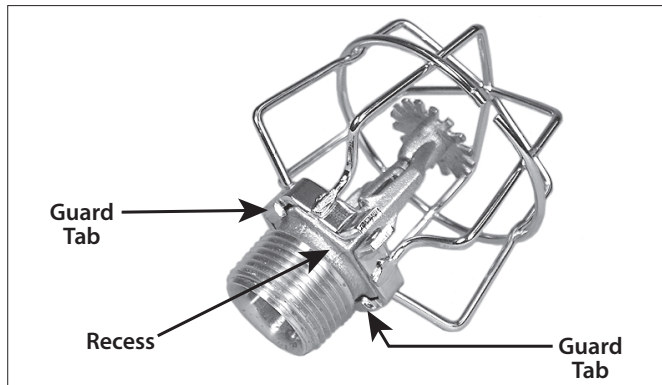

1. Install the guard onto the sprinkler. Verify that the tabs on the guard engage the recess between the wrench boss and the threads of the sprinkler.
2. Insert the two screws (provided) and tighten evenly.

## TESTING SPRINKLER SYSTEMS

After installation is complete, the entire sprinkler system shall be tested in accordance with current, applicable NFPA (NFPA 13, 13D, 13R, etc.) standards, or equivalent standards, and in accordance with applicable building and fire codes. In addition, the authority having jurisdiction may have additional maintenance, testing, and inspection requirements that shall be followed.

**NOTICE**



- A successful sprinkler system test is not a substitute for proper system installation and maintenance.

### VdS Approval Information

SIN	Approval Number	EC Certificate of Conformity
V2703	G 402 0046	0786-CPD-40235 0786-CPD-40004
V2704	G 402 0043	0786-CPD-40258 0786-CPD-40001
V2725	G 402 0048	0786-CPD-40262 0786-CPD-40006
V2726	G 402 0045	0786-CPD-40260 0786-CPD-40003
V2727	G 402 0047	0786-CPD-40261 0786-CPD-40005

## SPRINKLER REPLACEMENT

**WARNING**

- Always verify that the piping system has been completely depressurized and drained immediately prior to installation, removal, adjustment, or maintenance of any Victaulic products.
- Confirm that any equipment, branch lines, or sections of piping that may have been isolated for/during testing or due to valve closures/positioning are identified, depressurized, and drained immediately prior to installation, removal, adjustment, or maintenance of any Victaulic products.

• Any activities that require taking the valve out of service may eliminate the fire protection provided. A fire patrol is strongly recommended for the affected areas.

• Before servicing or testing the system, notify the authority having jurisdiction.

Failure to follow these instructions could result in death or serious personal injury and property damage.

1. **THE SYSTEM SHALL BE TAKEN OUT OF SERVICE IMMEDIATELY PRIOR TO REPLACEMENT OF SPRINKLERS.** Notify the authority having jurisdiction in the affected area that the fire protection system is being taken out of service and organize a fire patrol for the affected area.
2. Refer to the appropriate installation, maintenance, and testing manual for the system valve to relieve all pressure and drain all water from the system.
3. Remove the old sprinkler by using the proper sprinkler wrench. Install the new sprinkler in accordance with the instructions in the "Standard Sprinkler Installation" section on page 2 or the "Dry Sprinkler Installation" section on page 3. Verify that sprinklers are replaced with the proper model, style, orifice size, temperature rating, and response.
4. Place the system back in service by following the instructions in the appropriate installation, maintenance, and testing manual for the system valve.
5. Check the system for leaks and make any repairs immediately.
6. **SPRINKLER SYSTEMS THAT HAVE BEEN SUBJECTED TO A FIRE SHALL BE RETURNED TO SERVICE AS SOON AS POSSIBLE.** The entire system shall be inspected for damage and obstructions. Any damaged system components or any sprinklers that have operated shall be replaced. Sprinklers that have been exposed to corrosive, combustible products or high ambient temperatures shall be replaced. Contact the authority having jurisdiction in the local area for replacement requirements.

### VdS Approval Information

SIN	Approval Number	EC Certificate of Conformity
V2728	G 402 0044	0786-CPD-40259 0786-CPD-40002
V3401	G 402 0051	0786-CPD-40236 0786-CPD-40009
V3402	G 402 0049	0786-CPD-40263 0786-CPD-40007
V3423	G 402 0052	0786-CPD-40265 0786-CPD-40010
V3424	G 402 0050	0786-CPD-40264 0786-CPD-40008

For complete contact information, visit [victaulic.com](http://victaulic.com)

I-40 2239 REV U UPDATED 04/2021 Z000SPK002

VICTAULIC, FIRELOCK, IGS, AND INSTALLATION-READY ARE REGISTERED TRADEMARKS OR TRADEMARKS OF VICTAULIC COMPANY AND/OR ITS AFFILIATED ENTITIES IN THE UNITED STATES AND/OR OTHER COUNTRIES. © 2021 VICTAULIC COMPANY. ALL RIGHTS RESERVED.

