

- LMD RED7 18mm 2018.03.09.-

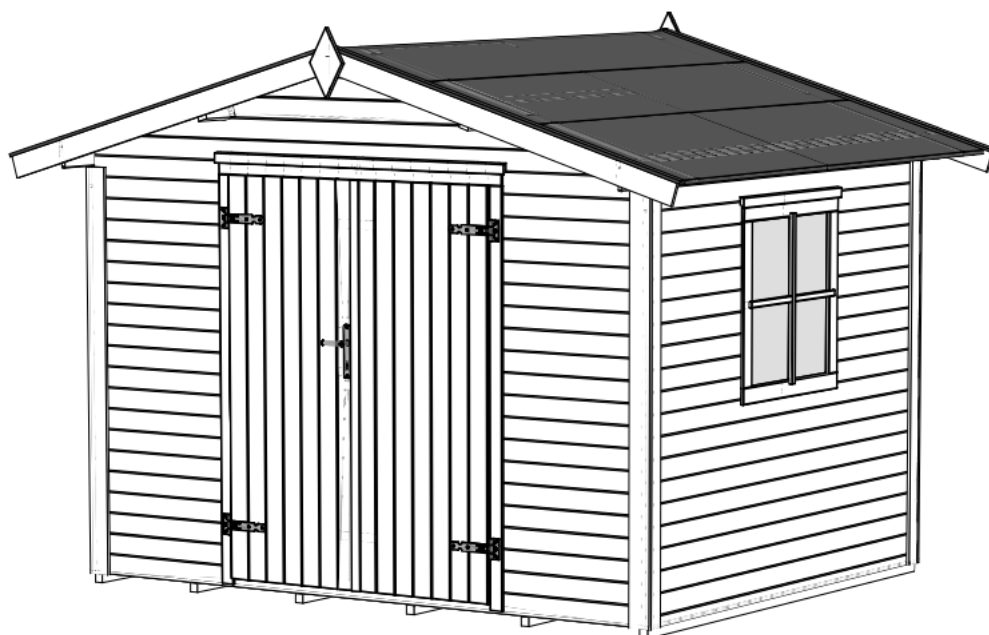

Nyt livet hjemme

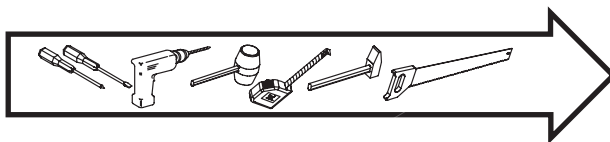

LMD REDSKAPSBOD 7' ern 2822 18MM FIX

Art.Nr. 59192800

Ean.Nr. 5999553064537



ETA-15/0873



Hout voor Outdoor Life Products blokhutten en tuinhuizen is vooral afkomstig uit gecertificeerde en goed beheerde bossen.
Wood used for our Outdoor Life Products cabins and garden houses is mostly sourced from certified and well-managed forests.
Das Holz für Outdoor Life Products Blockbohlenhäuser und Gartenhäuser wird größtenteils aus zertifizierten Wäldern bezogen.
Les bois pour chalets et maisons de jardin de Outdoor Life Products proviennent en grande partie de forêts certifiées et gérées durablement.

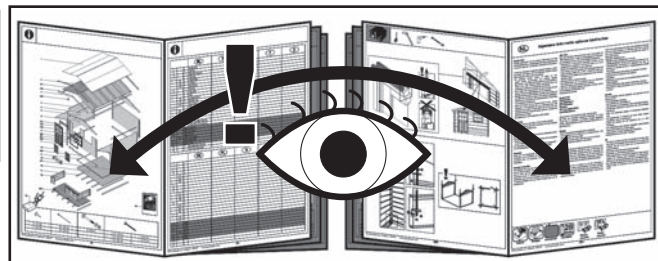

Gartenpro Kft., www.gartenpro.hu - www.outdoorlifegroup.eu
Soproni uti lpartelep, 9444 Fertöszentmiklos, Ungarn

1 Generelt



Les monteringsanvisningen grundig før du går i gang med å sette sammen huset!

- La huset være innpakket og oppbevar det på et tørt sted, ikke i direkte kontakt med bakken og godt beskyttet mot vær og vind (fuktighet, solskinn osv.), helt frem til det skal monteres. Huspakken må ikke oppbevares i et oppvarmet rom!
- Når du skal bestemme hvor hagehuset skal stå, må du ta hensyn til at det ikke bør utsettes for ekstreme værforhold (områder med kraftig snøfall eller sterk vind); ellers må du feste det med forsterkning til bakken.

Dette huset er fremstilt av høykvalitets furu og leveres ubehandlet. Dette huset har gjennomgått en grundig inspeksjon. Dersom du likevel skulle ha grunn til reklamasjon, ber vi deg fylle ut kontrollskjema og sende det sammen med kjøpsbeviset og kvitteringen til forhandleren.

OBS: Sørg for å oppbevare all dokumentasjon som følger med huspakken! Husets serienummer er oppført på kontrollskjema. Vi kan kun behandle en reklamasjon dersom du sender husets serienummer til forhandleren!

Garantien dekker ikke:



Garanti

- Særegenhet i treverket som et naturlig materiale
- Deler av huset som er blitt malt (behandlet med trebevaringsmidler)
- Deler av huset som inneholder hele kvister som ikke representerer en fare for husets stabilitet
- Variasjoner i fargetone som er forårsaket av forskjeller i trestrukturen og som ikke har betydning for treverkets levetid
- Deler av huset som sprekker (på grunn av tørking) små sprekker/riss som ikke er gjennomgående og som ikke påvirker husets struktur
- Deler av vridd tre som likevel kan monteres
- Tak- eller gulvplank som på skjulte overflater kan oppvise uhøvlede områder, fargeforskjeller og vankant
- Reklamasjoner fordi huset er blitt montert på ukyndig måte eller fordi huset siger på grunn av ukyndig utført fundament
- Reklamasjoner fordi det er blitt gjort endringer på huset på eget initiativ, som f.eks. formendringer på deler av tre eller dører/vinduer på grunn av ukyndig behandling av treverket; at stormavstivere er festet for stramt, dørkarmer er blitt skrudd inn i veggstokker osv.

Reklamasjonene som dekkes av garantien er begrenset til å omfatte erstatning av manglende/feil materiale. Alle andre krav utelukkes!

Maling og vedlikehold av hagehuset

Tre er et naturlig materiale som vokser og tilpasser seg i forhold til værforholdene. Større eller mindre sprekker, fargeforskjeller og endringer samt ulikheter i treets struktur er ikke feil, men et resultat av treets vekst og en særegenhet i treverket som et naturlig materiale.

Ubehandlet treverk (unntatt bærebjelker i fundamentet) blir grått hvis det blir værende ubehandlet over tid og kan bli blått og begynne å råtne. For å beskytte treverket i hagehuset, må det før montering behandles med grunning.

Alle deler må behandles med grunning (f. eks. Visir) på alle sider (innvendig og utvendig), laftespor, not og fjær, før montering.

- Husk:
- Endeved 3-4 strøk vått i vått.
 - Grunn vinduer og dører på alle sider.
 - Grunn tak/gulvbord på alle sider.



Hvorfor grunning?

Det er ekstra mye endeved i en laftehytte. Hvert eneste laftespor har endeved. Det er endeveden som tar til seg mest fuktighet i treverk. Ved produksjon av en laftehytte blir treverket tørket før det blir produsert. Dette gjør at delene lettere tar til seg fuktighet når pakken blir åpnet. Tørket trevirke som blir utsatt for fuktighetssvingninger vil ofte vri seg og skape spenninger i treverket som kan utløse mange problemer. En grunning sin viktigste funksjon er å redusere fuktopptak og dermed redusere spenningsproblemer. Den andre viktige funksjonen til en grunning er å hindre dannelse av sopp og råte. Dette oppstår gjerne på steder som har dårlig lufting, som f. eks. i laftesporene.

Når huset er ferdig montert, må det ferdige huset behandles med et værbestandig malingsstrøk utvendig som beskytter treverket mot fuktighet og UV-stråler. Innvendig må huset etterbehandlet i henhold til bruksmønster.

Bruk malerredskaper og maling av høy kvalitet når du maler huset. Følg anvisningene på malerspannet og malingsprodusentens sikkerhets- og bruksanvisninger. Du må aldri male en overflate i sterkt sollys eller i regnvær. Forhør deg hos en malerspesialist når det gjelder hvilken maling som egner seg for ubehandlet myktre, og følg anvisningene fra produsenten.

Dersom huset er blitt malt på riktig måte, vil husets levetid forlenges betraktelig. Vi anbefaler at du inspiserer huset grundig hvert halvår.

LMD REDSKAPSBOD 7' ern 2822 18MM FIX

Art.Nr. 59192800



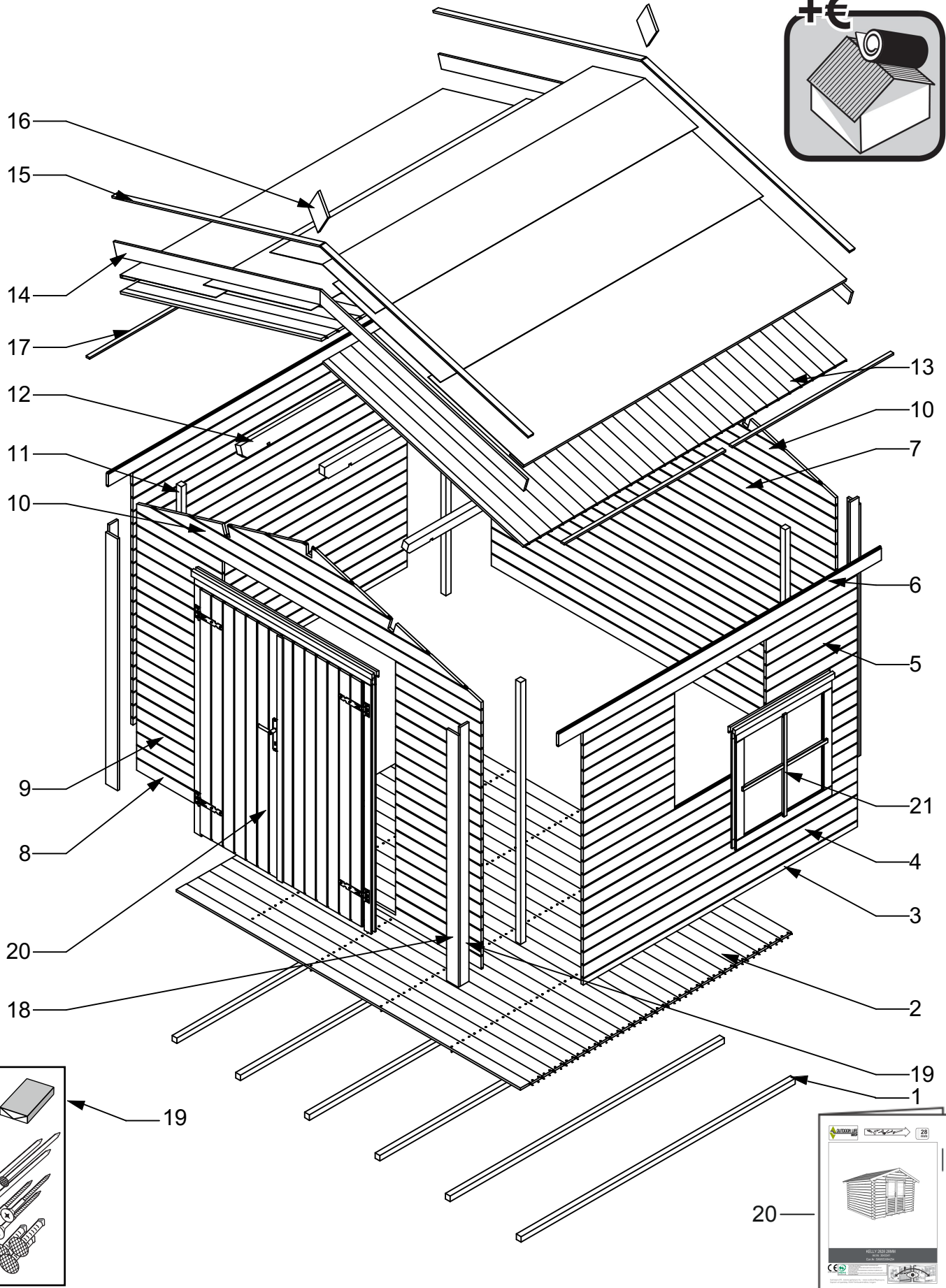









Ean.Nr. 5999553064537

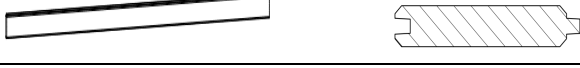
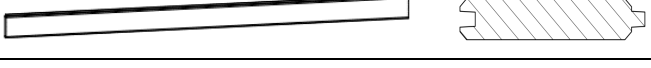
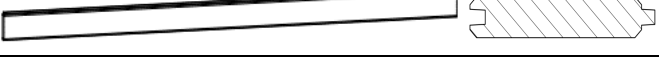
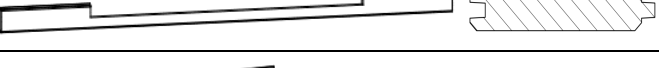
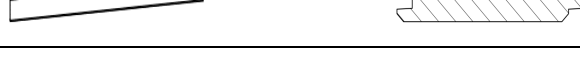
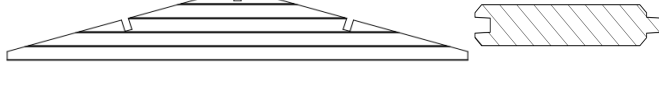

LMD REDSKAPSBOD 7' ern 2822 18MM FIX

Art.Nr. 59192800

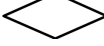
Ean.Nr. 5999553064537

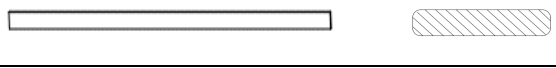
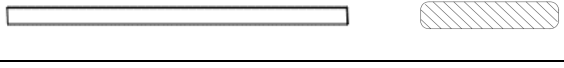
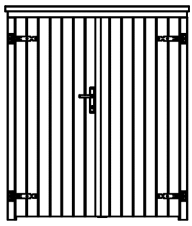

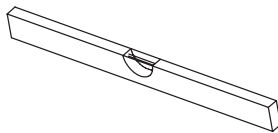
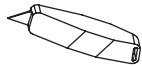
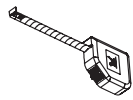
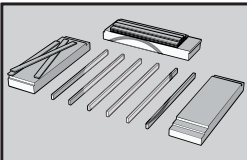
1.		40X60X2200	6X
2.		15X99X2762	25X
3.		18X52X2200	2X
4.		18X98X2200	29X
5.		18X98X732	18X
6.		18X98X2590	2X
7.		18X98X2764	20X
8.		18X98X2764	1X
9.		18x98x687	38X
10.		18X457X2764	2X
11.		43X43X1820	4X
12.		43X90X2590	3X
13.		15X99X1680	58X
14.		15X95X1720	4X
15.		12X26X1740	4X
16.			2X
17.		12X42X1290	4X
18.		15X95X1750	4X
19.		15X70X1800	4X
20.		D-HYBRID-18	1X



LMD REDSKAPSBOD 7' ern 2822 18MM FIX

Art.Nr. 59192800

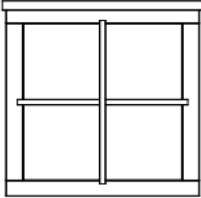
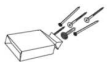
Ean.Nr. 5999553064537

21.		NEWPORT-FIX-P-18	1X
22.		7061208 Cs BAUHAUS 2323 18.	1X
23.		Reds 7' Ern 2822	1X

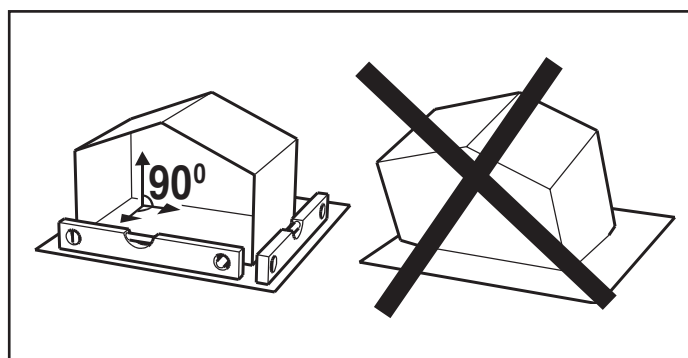
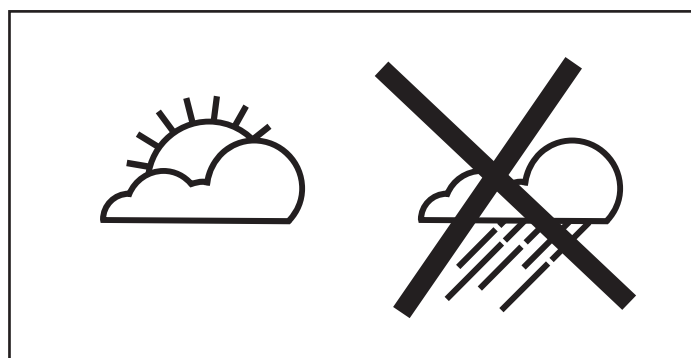
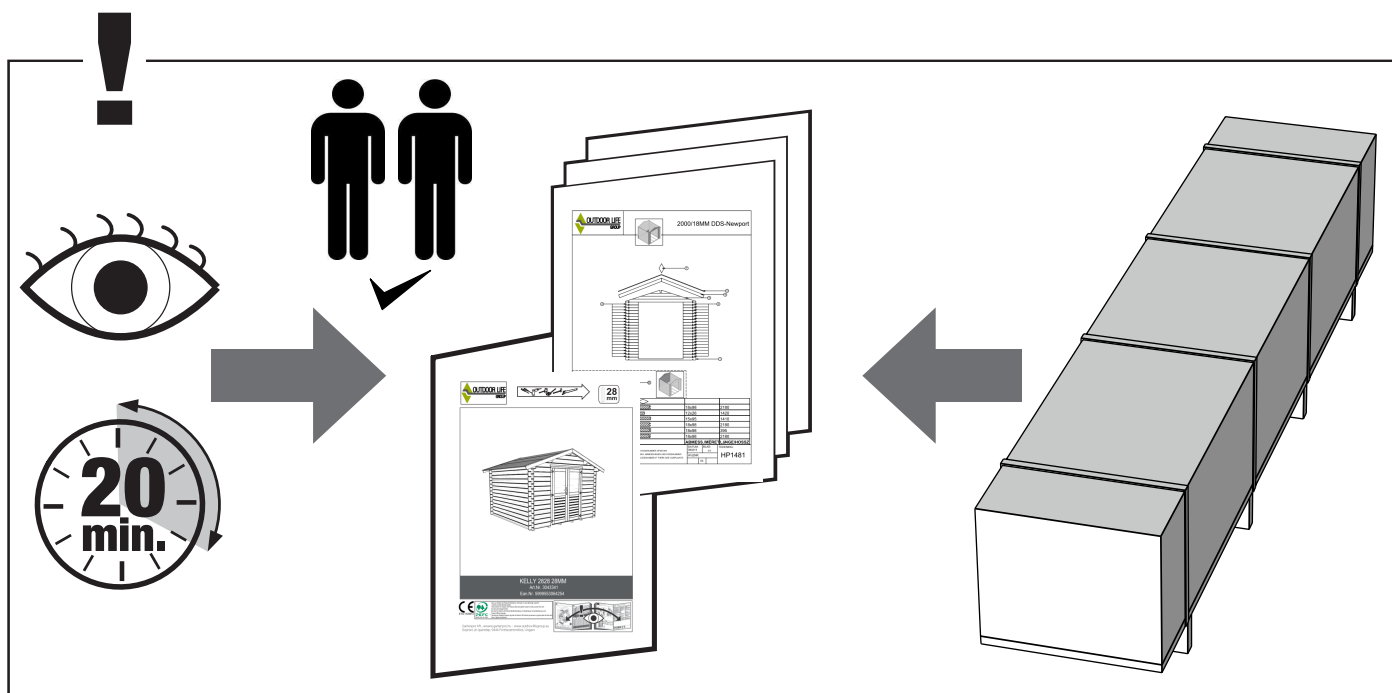

1

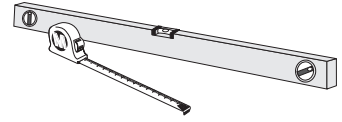
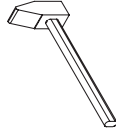

C

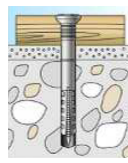
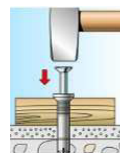
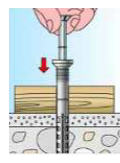
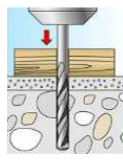
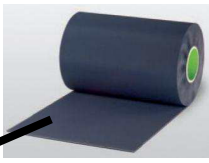
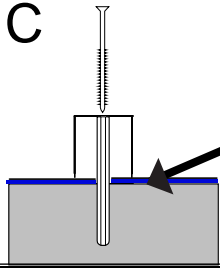

POS

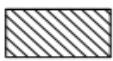
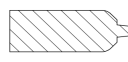
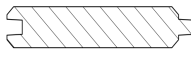
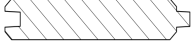
- 1.  40x60x2200 6X
- 3.  18x52x2200 2X
- 7.  18x98x2764 1X
- 8.  18x98x2764 1X

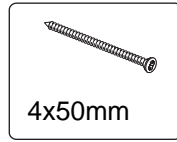

X16

4x50mm

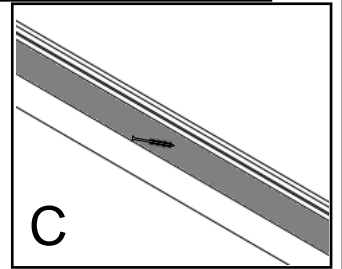

C

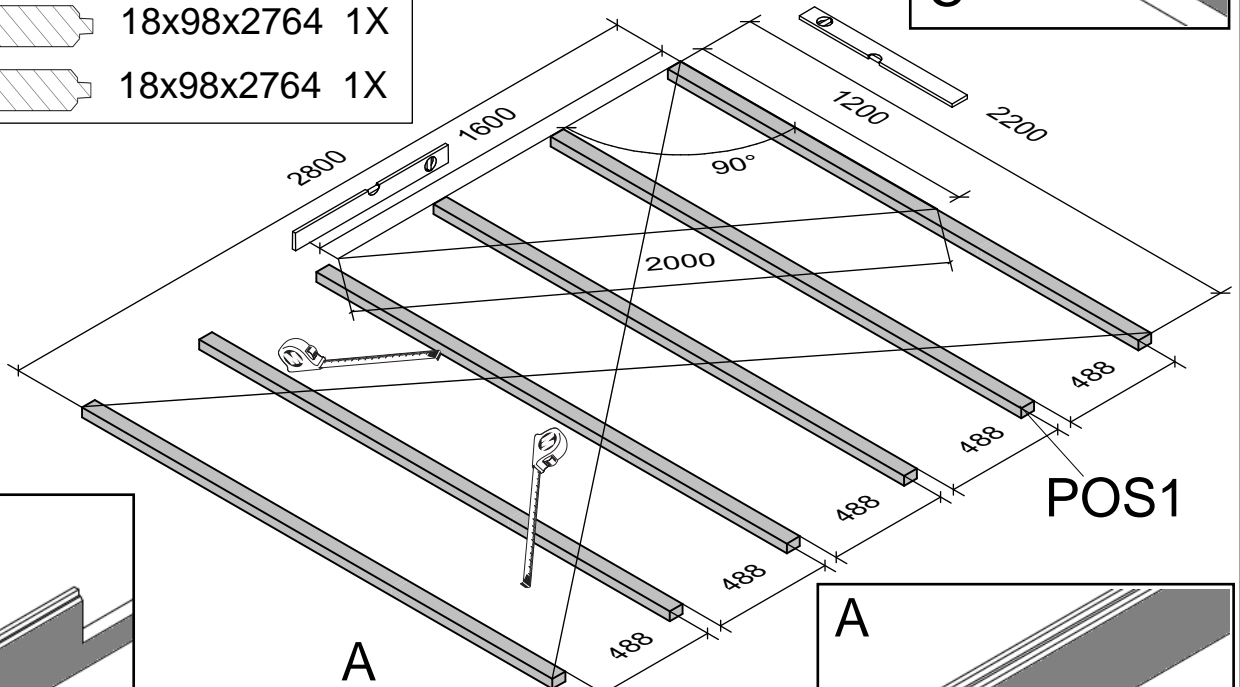

POS1

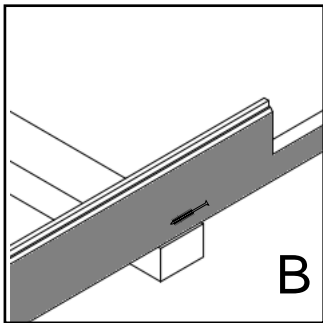

B

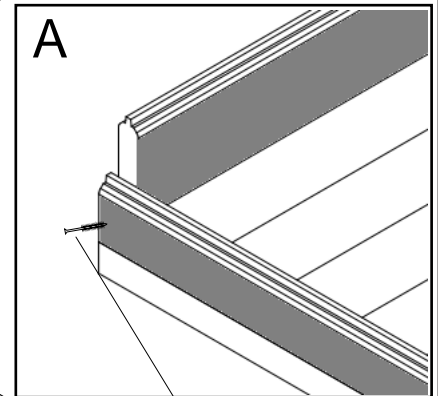

A

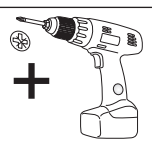
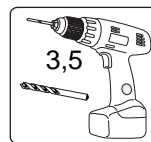
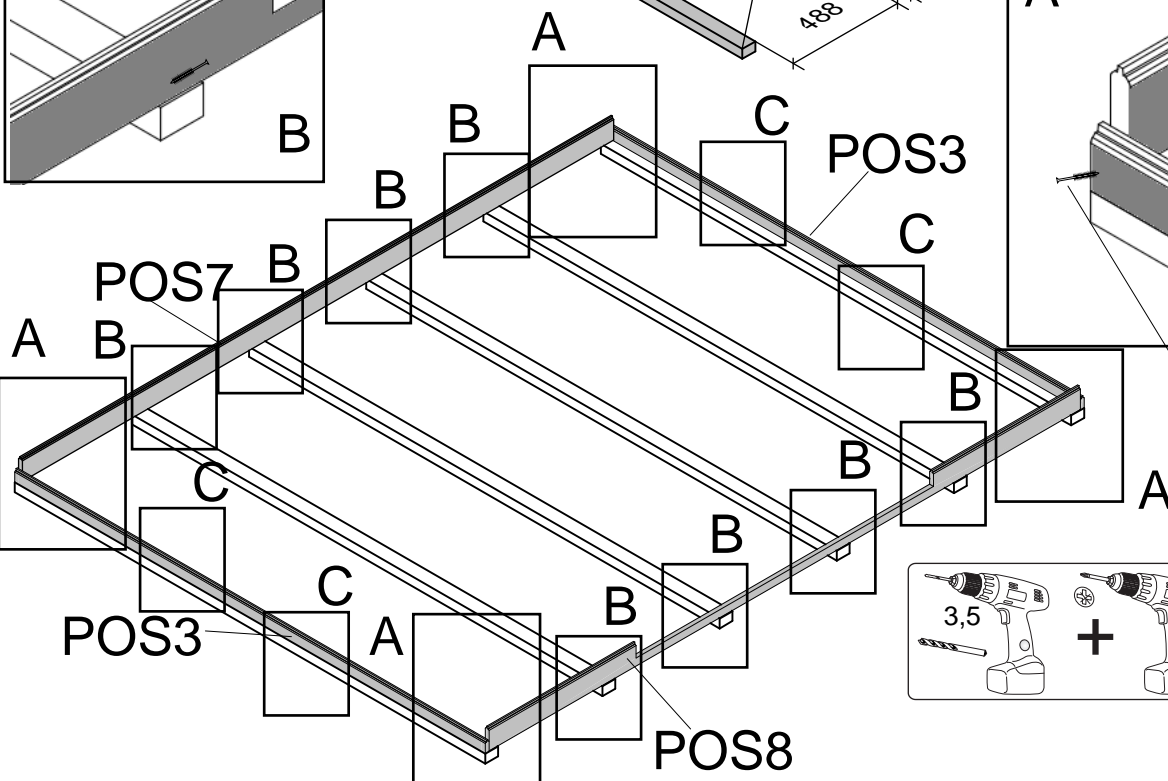

3,5

4x50mm

2

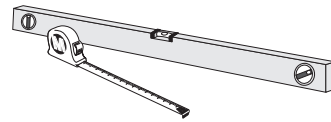
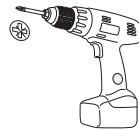
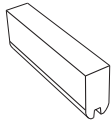
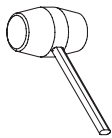

POS

2.



15X99X2762 25X

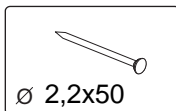

300X

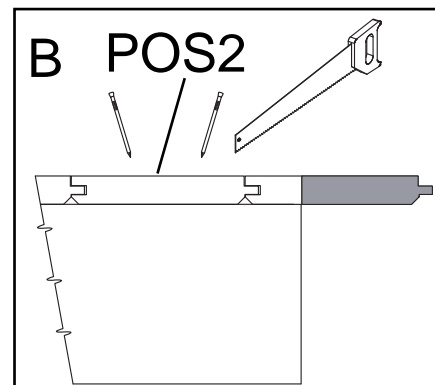
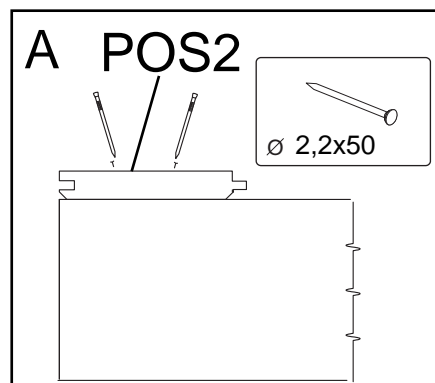
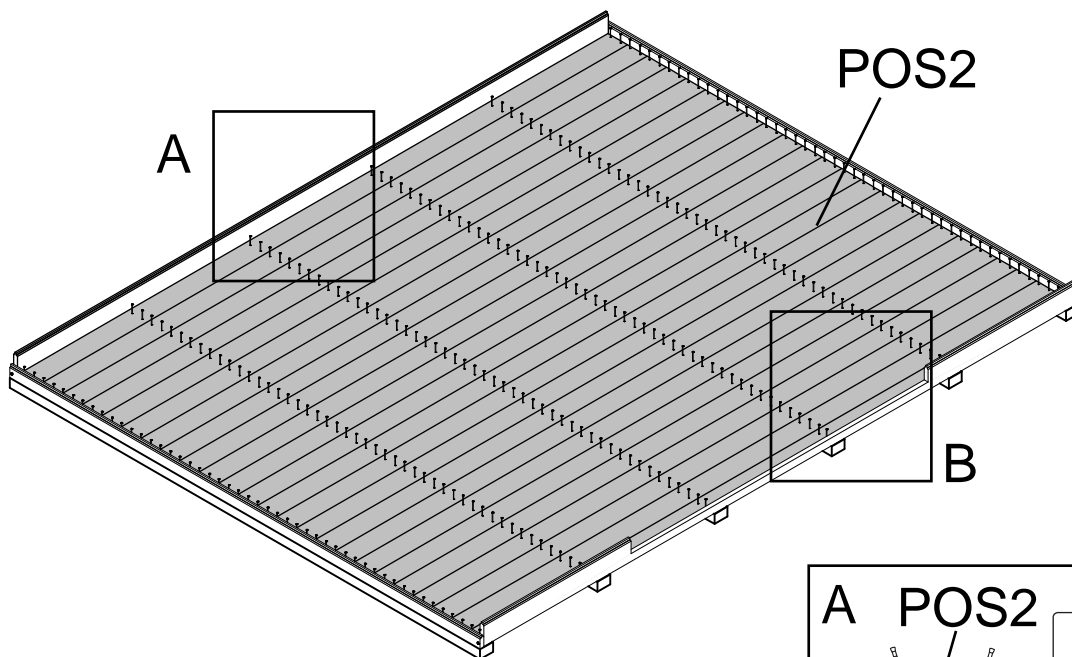
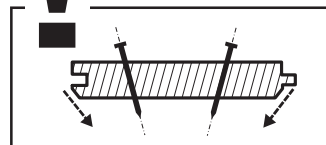
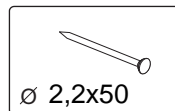

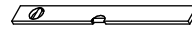
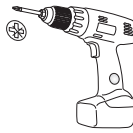
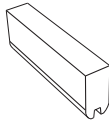
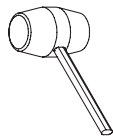
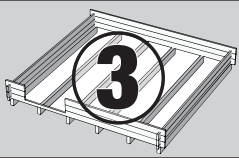

POS

11.  43X43X1820 4X

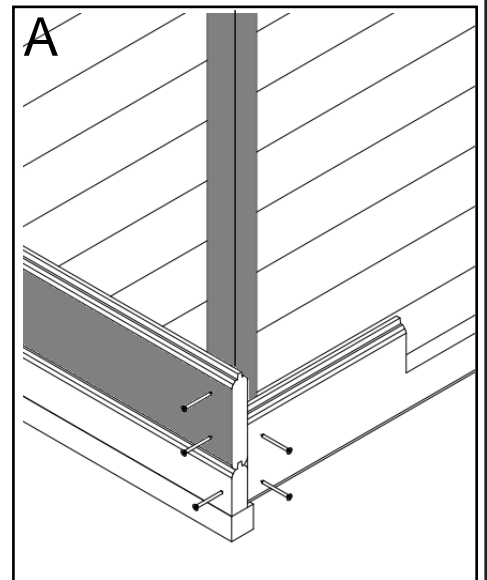
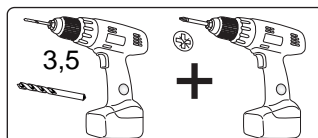
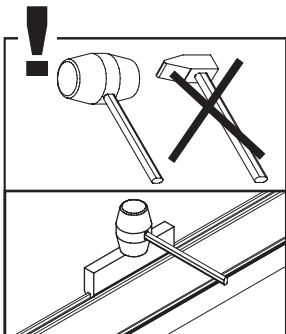
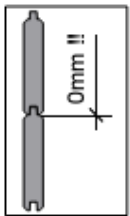
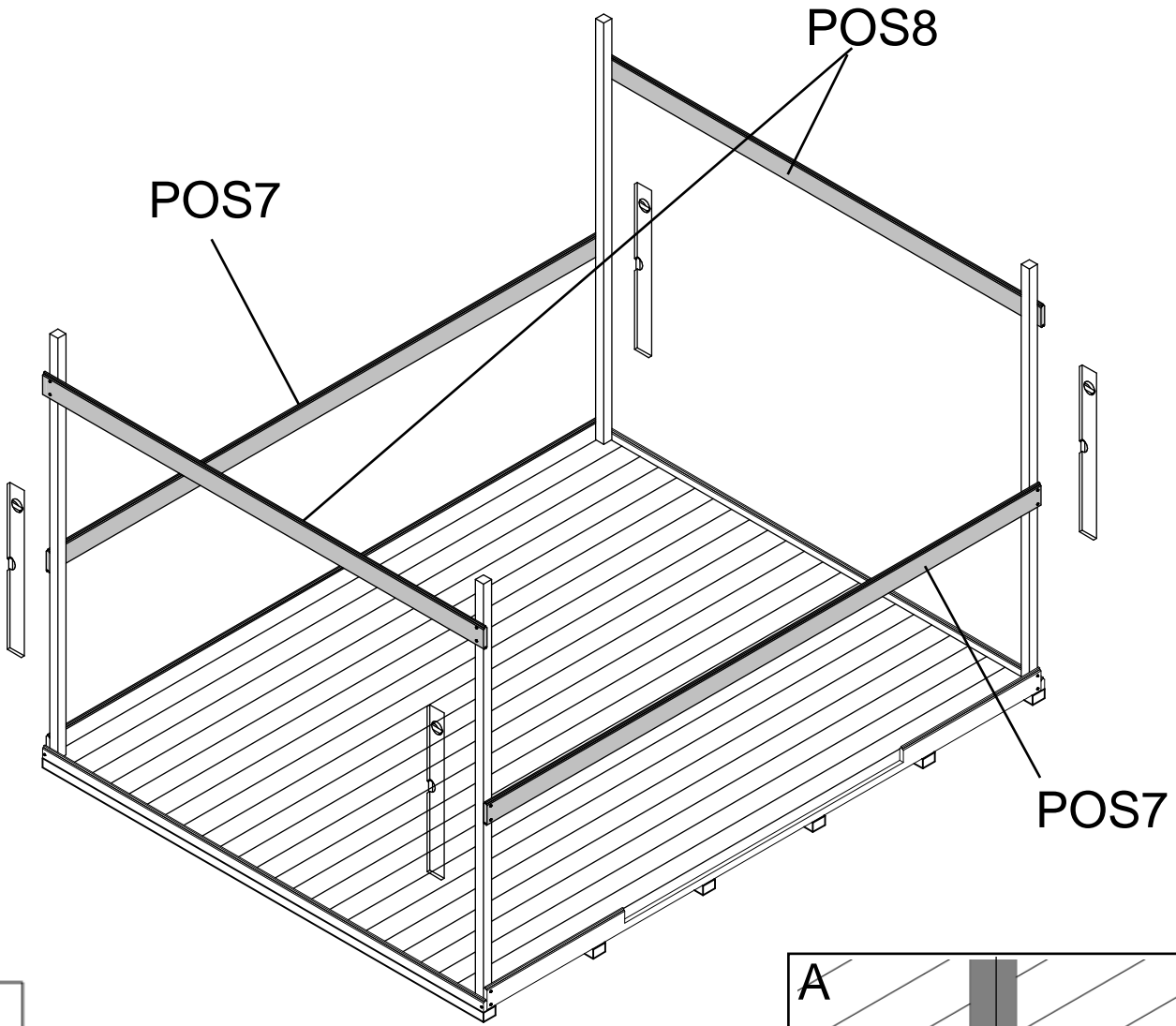
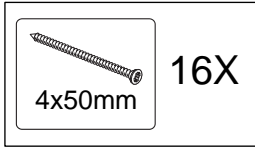

7.  18x98x2764 2X

8.  18x98x2200 2X

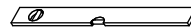
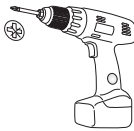
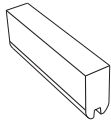
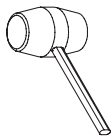
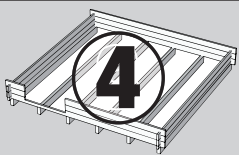



POS

- 7.  18x98x2764 4X
- 8.  18x98x2200 10X
- 9.  18x98x687 10X

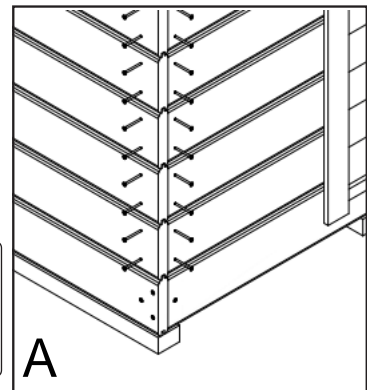
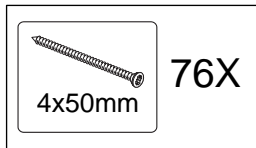

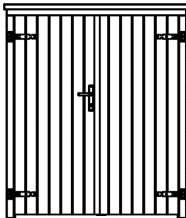
- 20.  D-HYBRID-1 1X

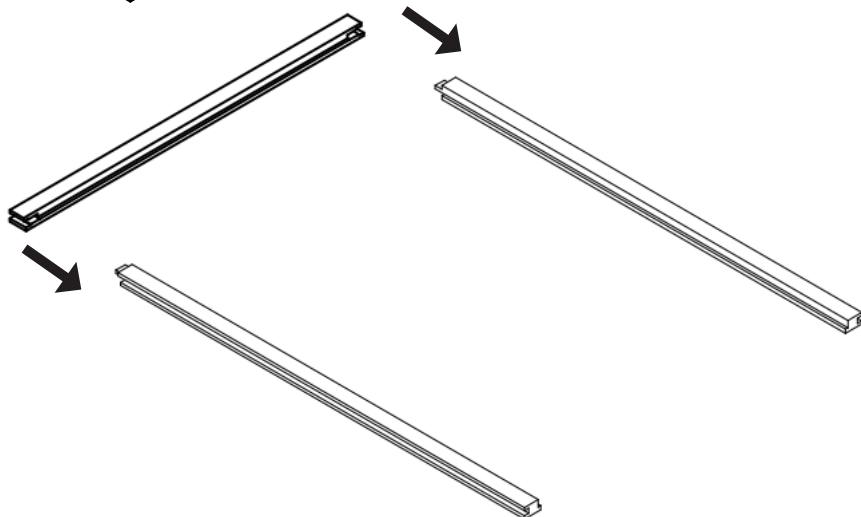
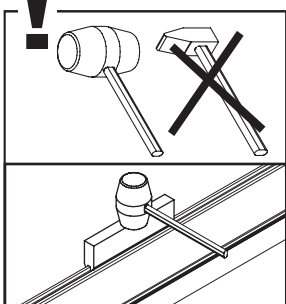
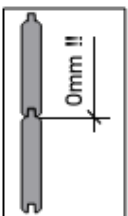
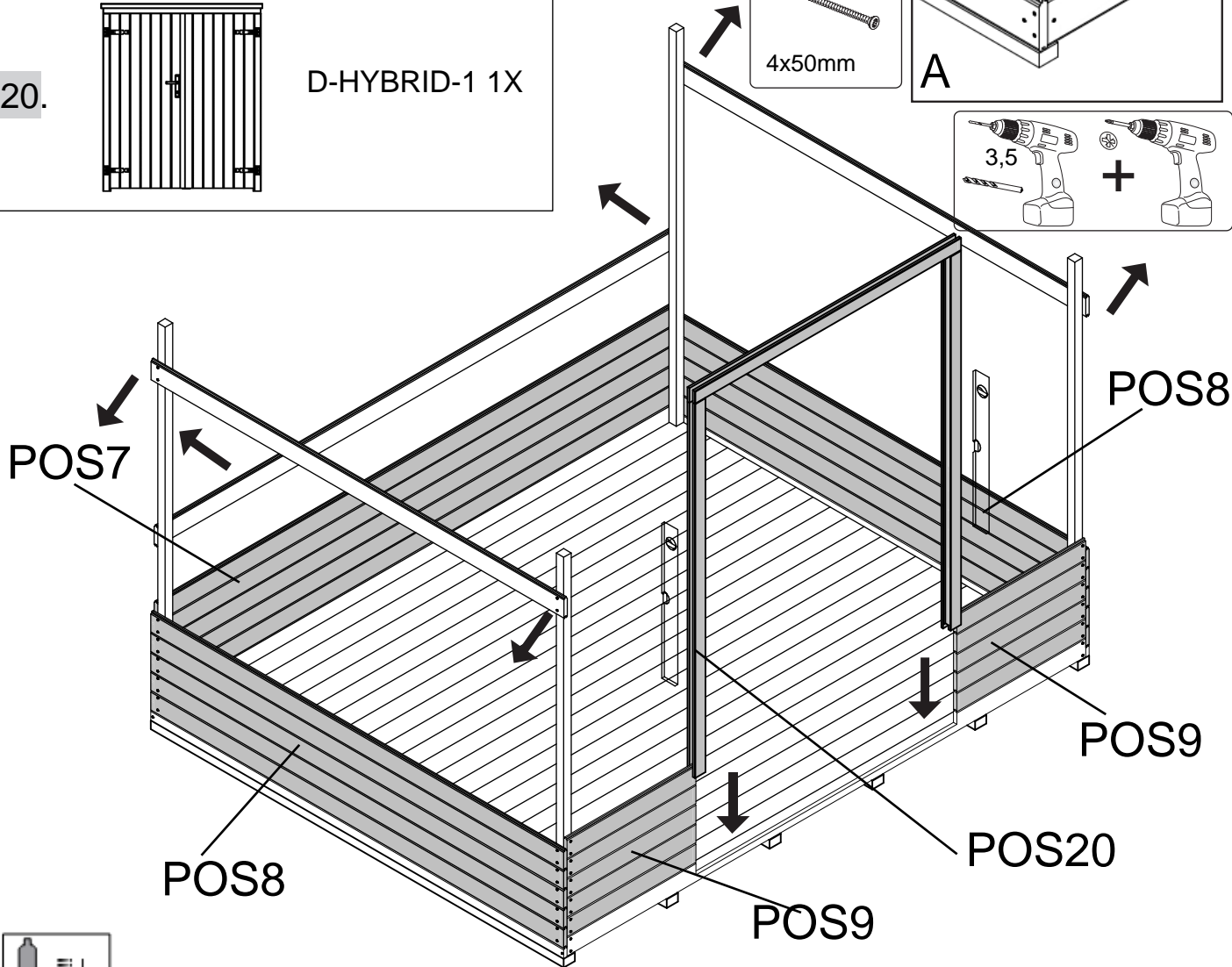
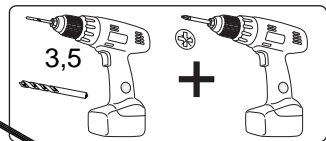

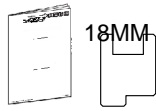
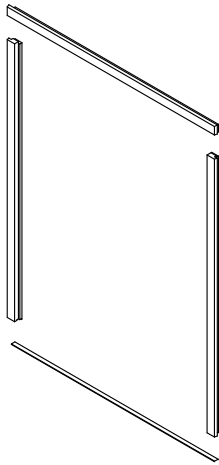
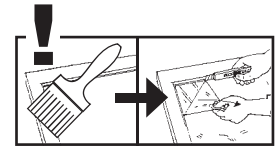
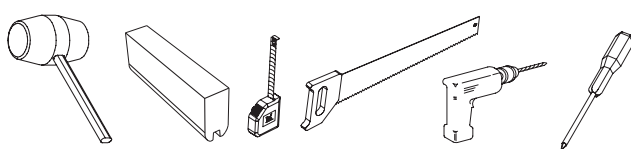

DDS
NEWP

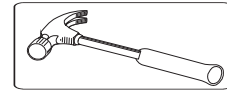
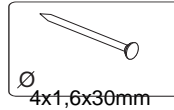
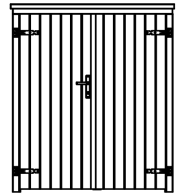

1.

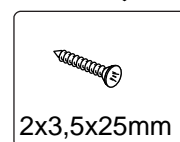
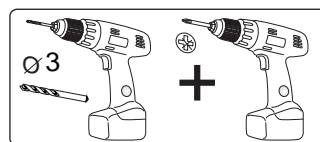
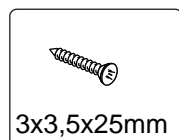
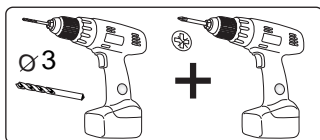
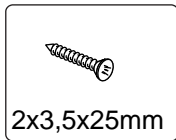
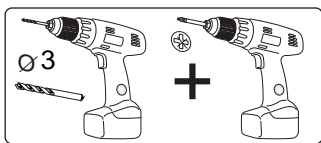
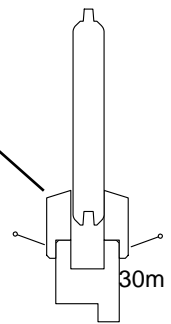
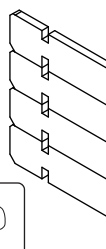
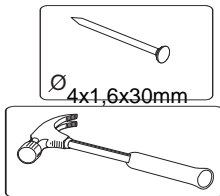
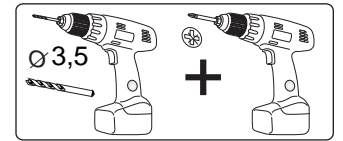
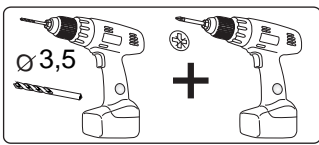

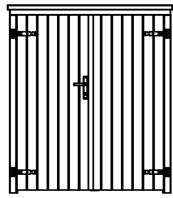
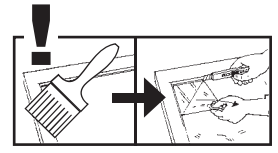
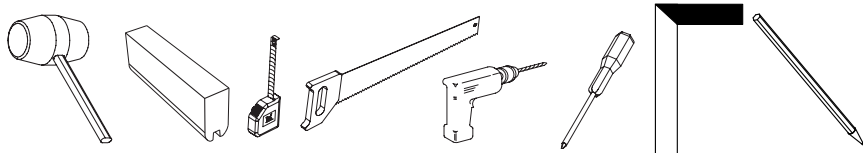

D-HYBRID

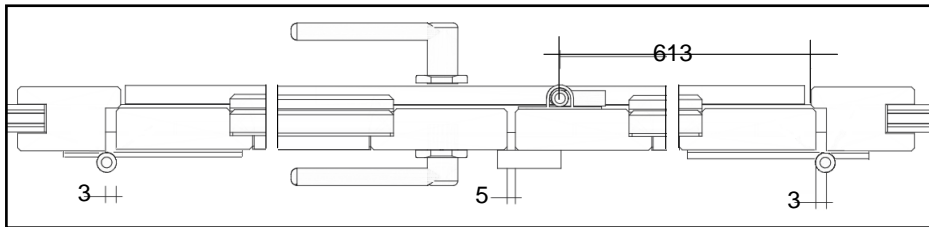
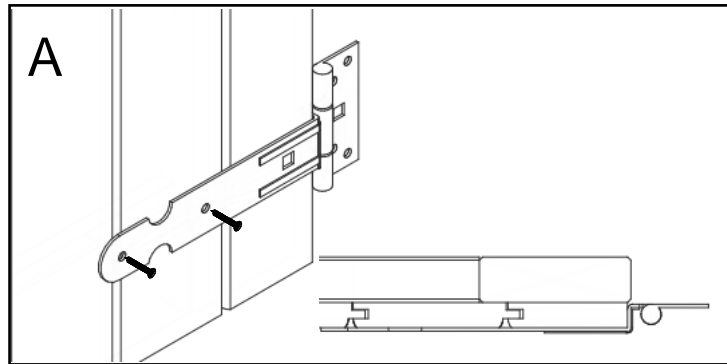
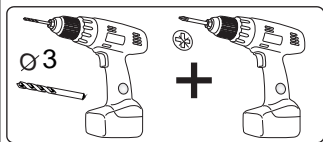
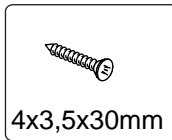
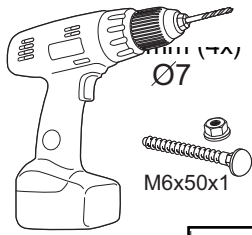
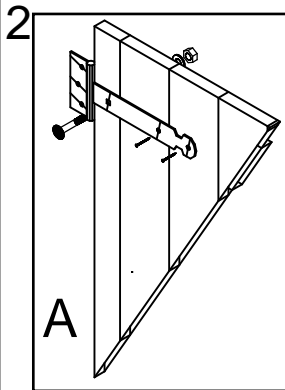
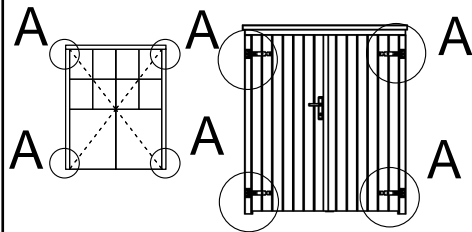

6.

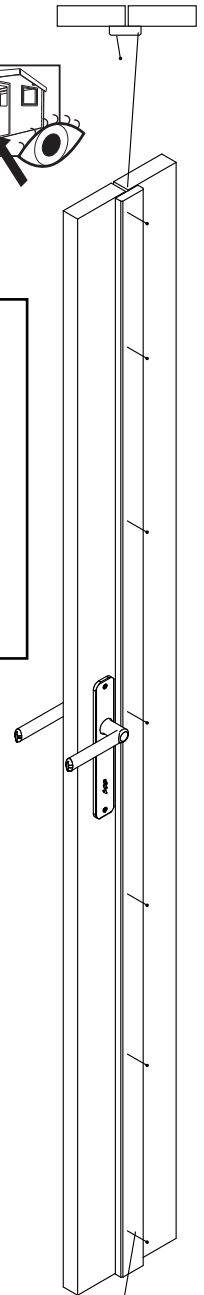
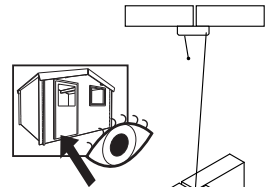

5.

6.

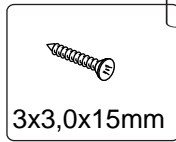
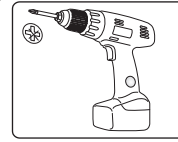
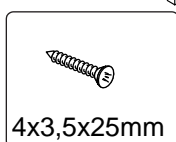
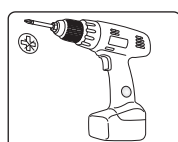
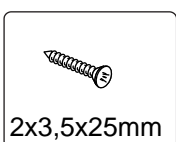
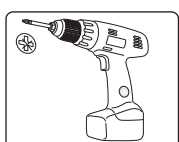
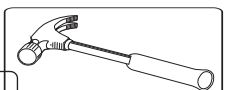
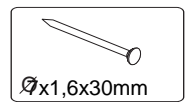
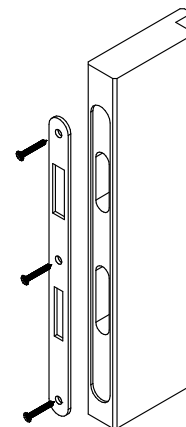
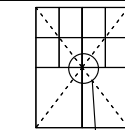
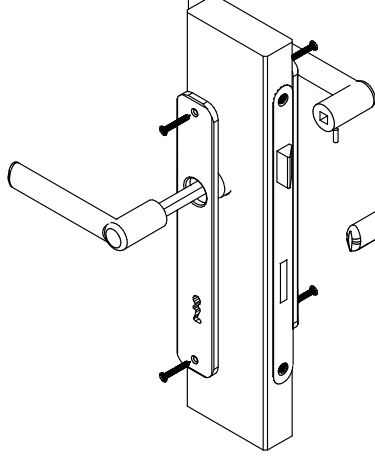
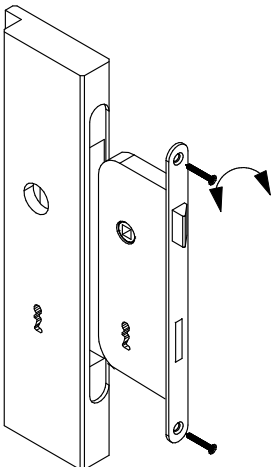

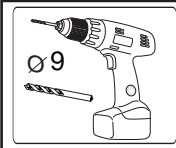
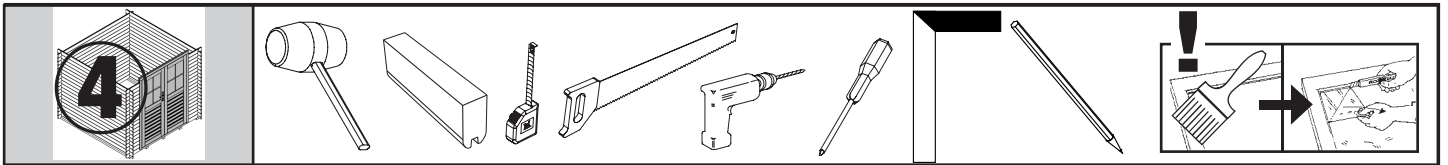



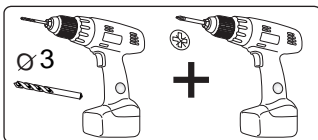
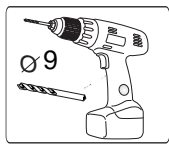
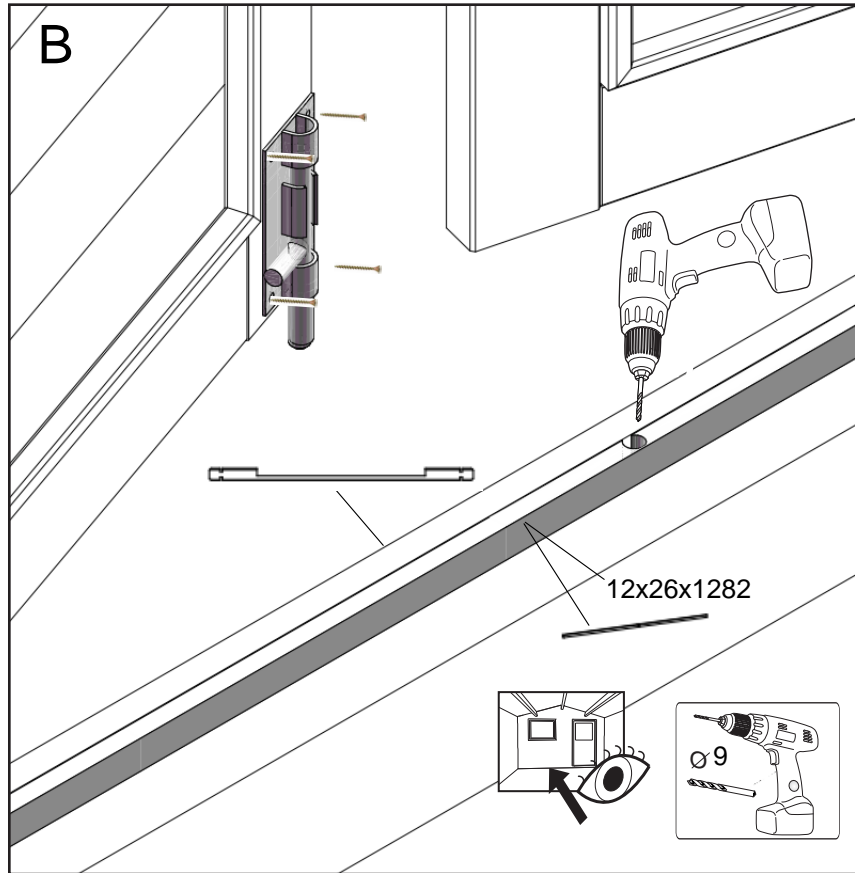
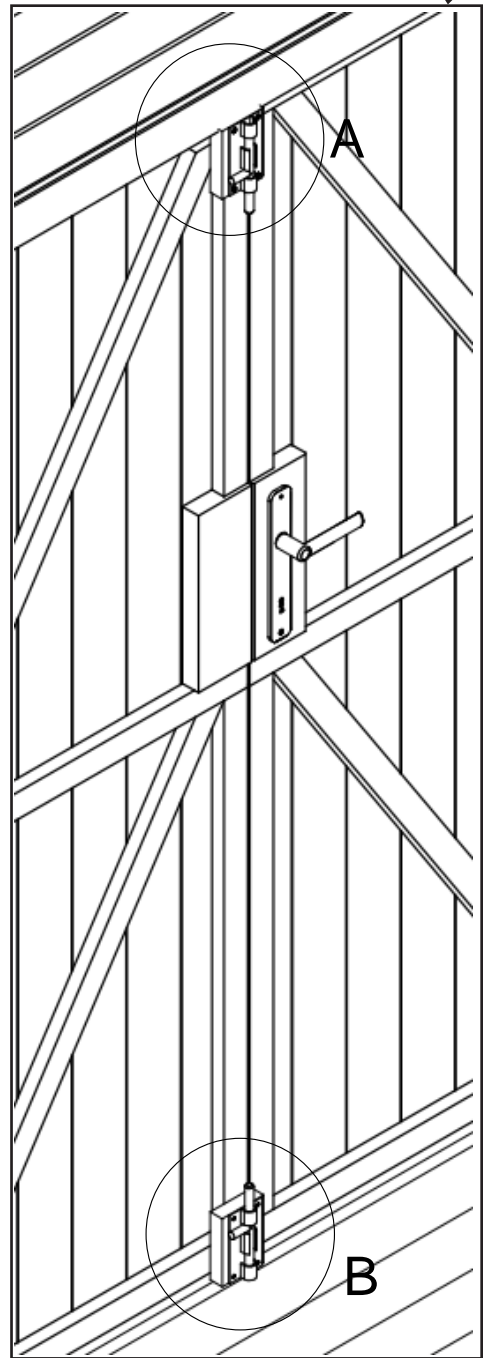
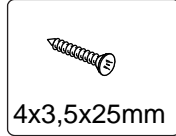
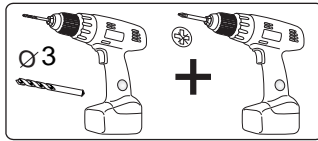
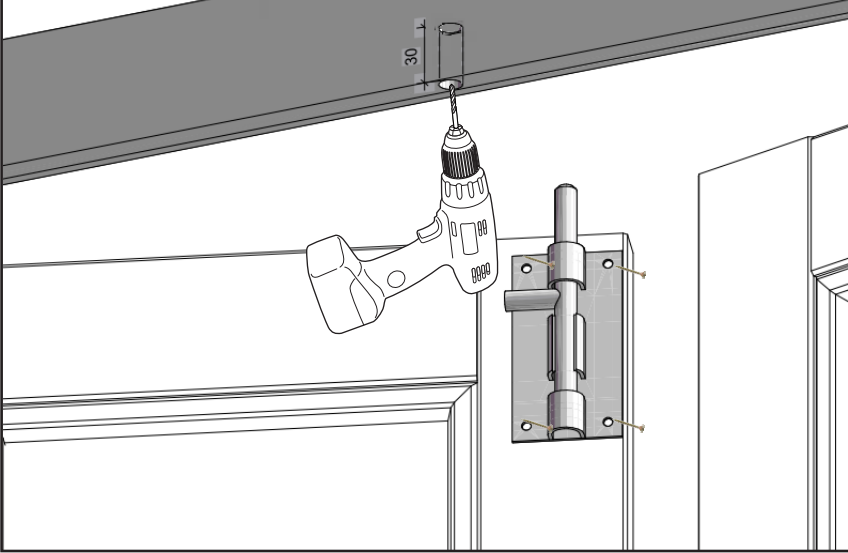

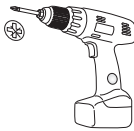
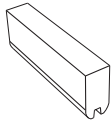
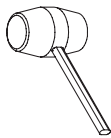
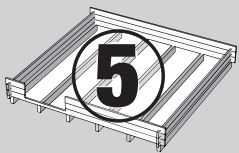
A





POS

- 7.  18x98x2764 15X
- 8.  18x98x2200 18X
- 9.  18x98x687 28X
- 5.  18x98x732 18X

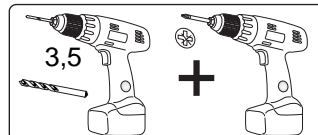
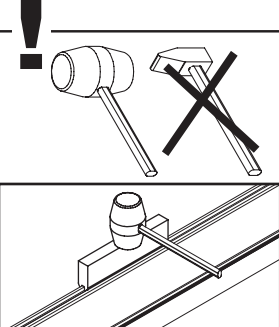
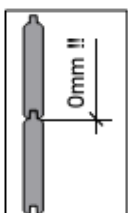
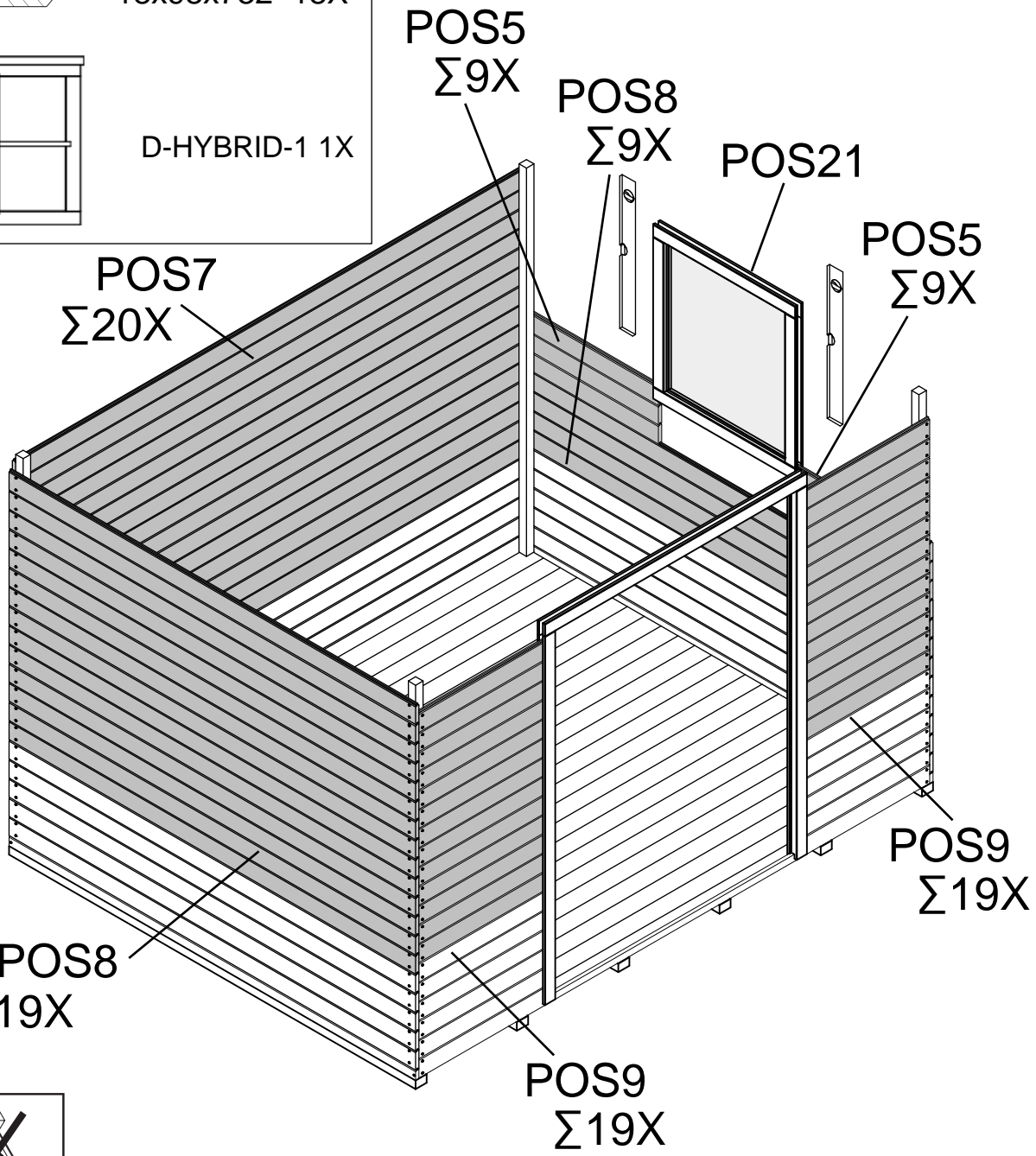
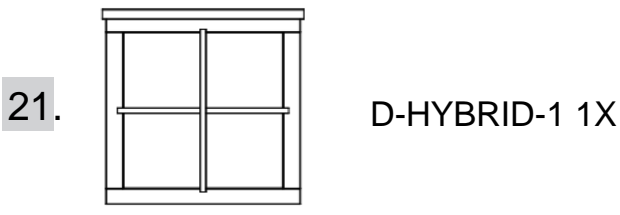
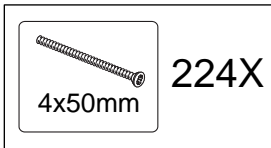

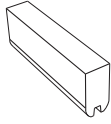
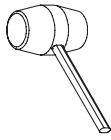
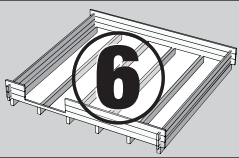

POS

6.  18x98x2590 2X

 12X
4x50mm

10.  18x457x2764 2X

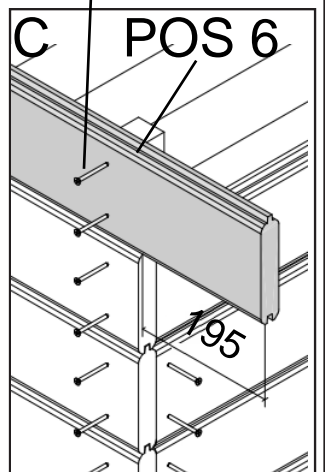
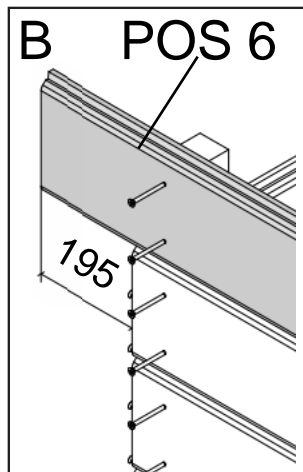
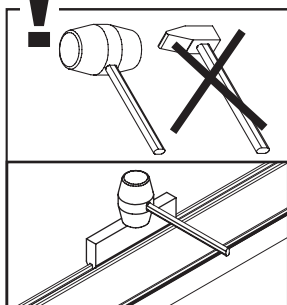
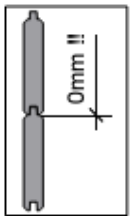
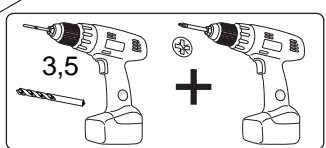
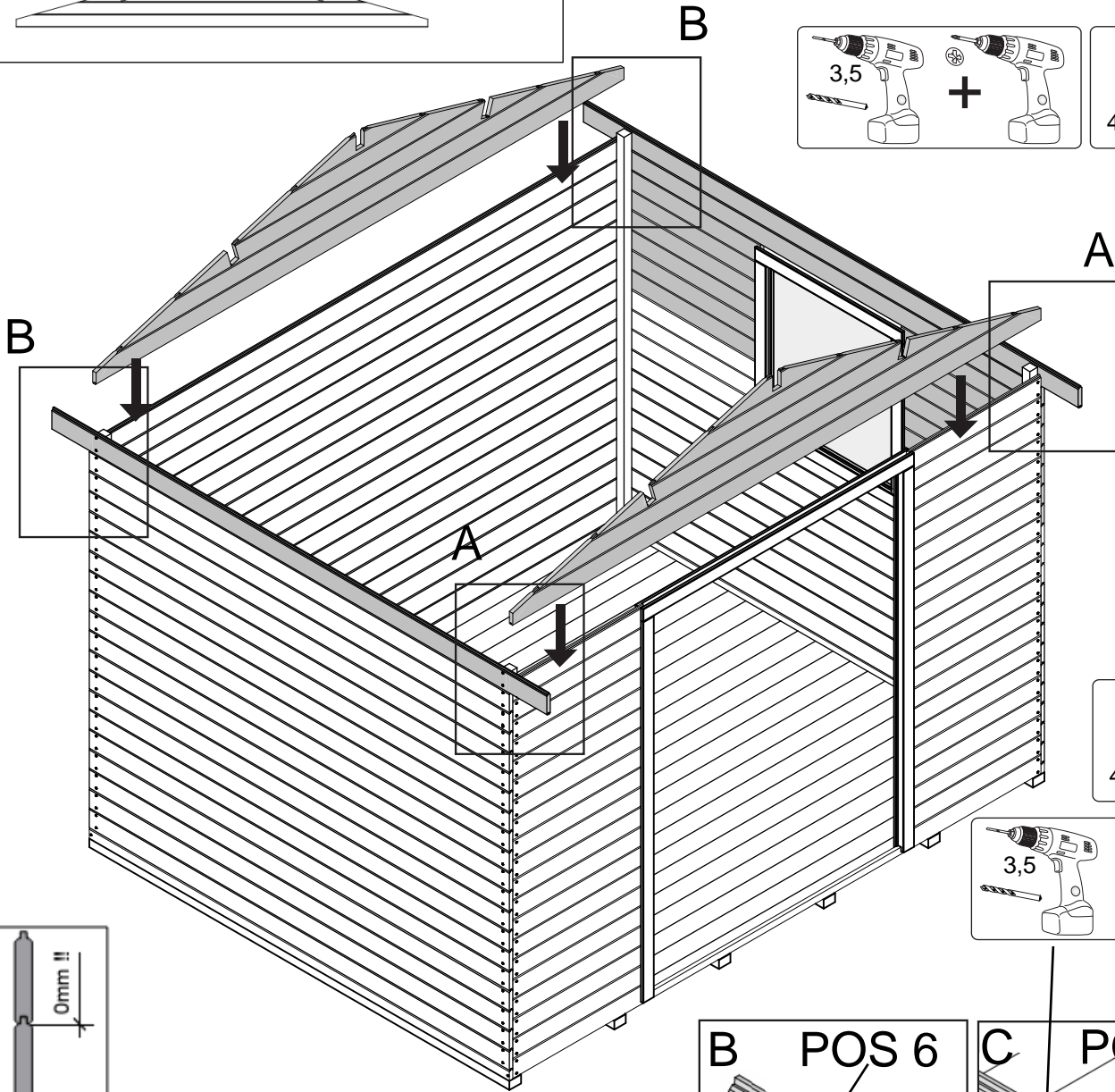
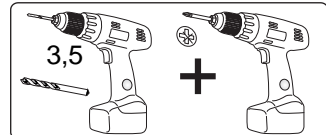

7

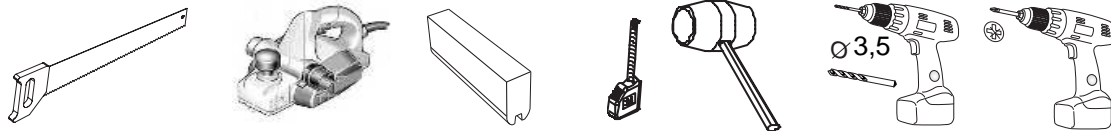

POS

12.



43x90x2590 3X

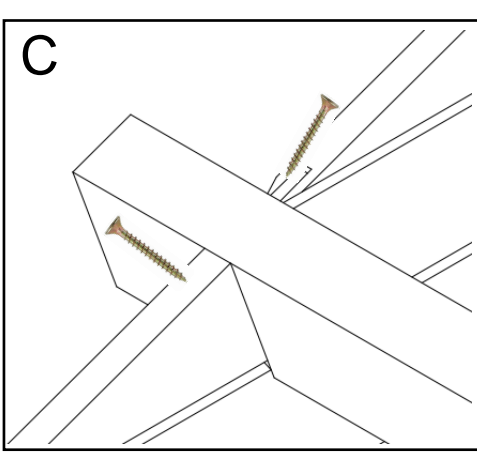
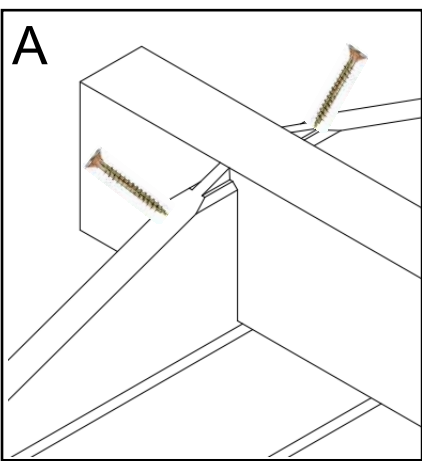
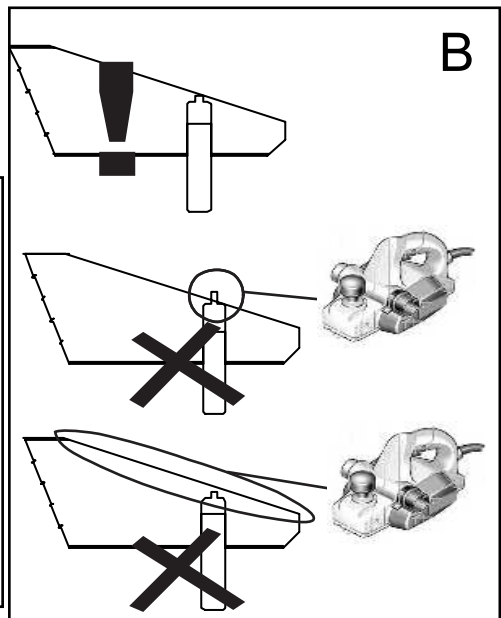
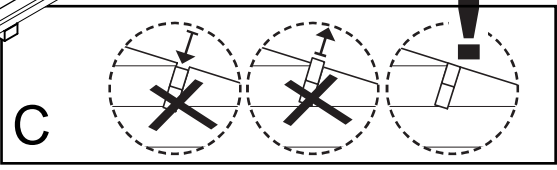
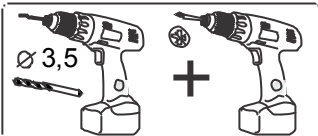
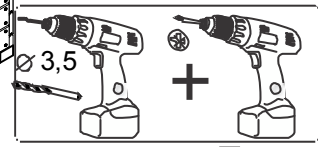
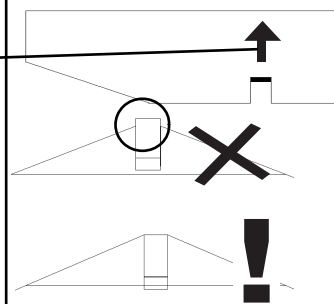
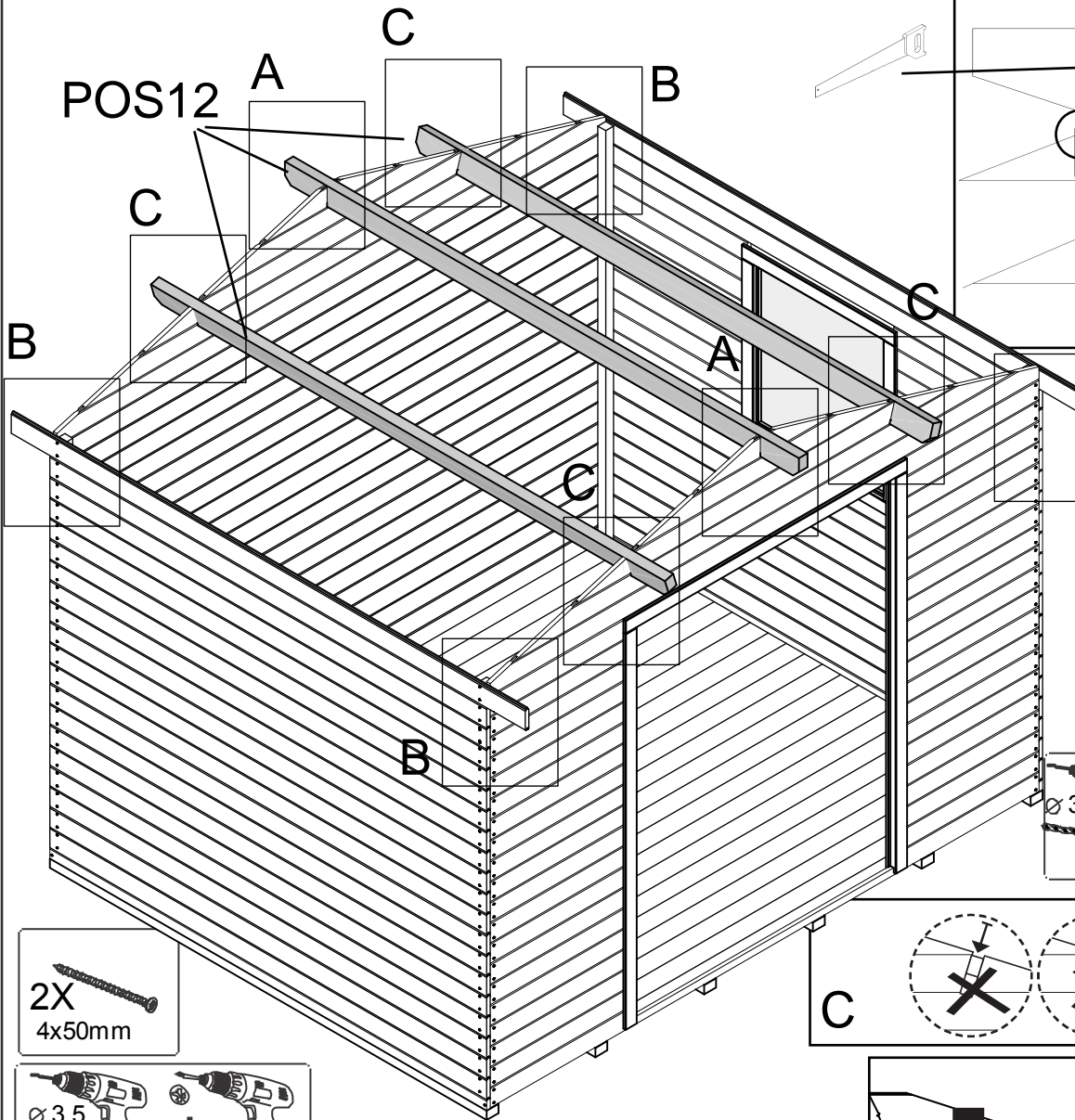
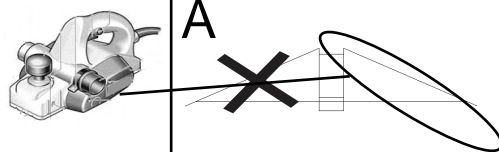
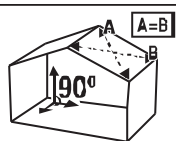

7

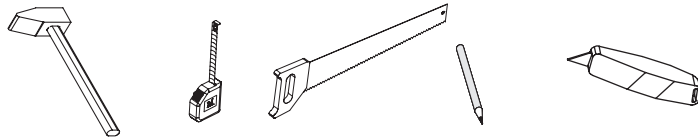



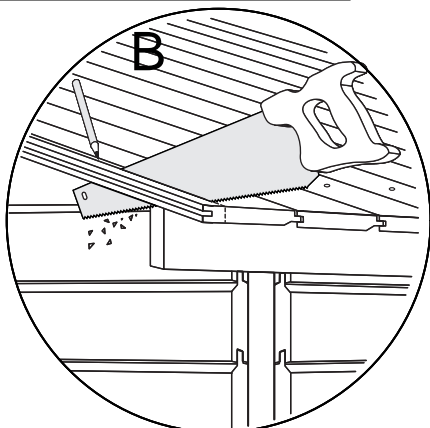
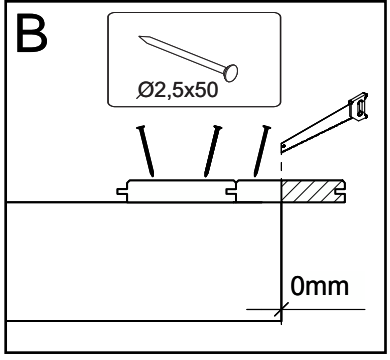
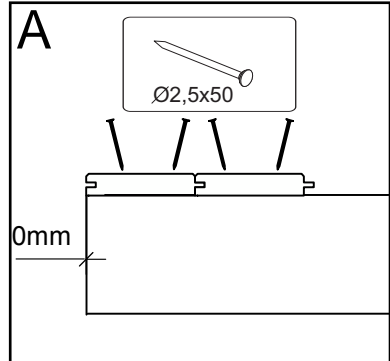
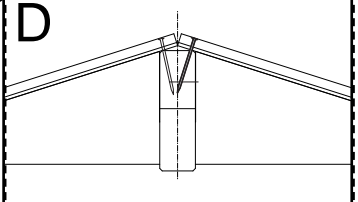
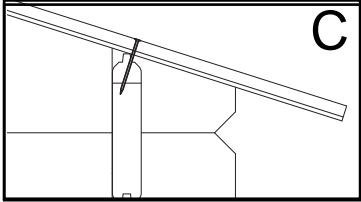
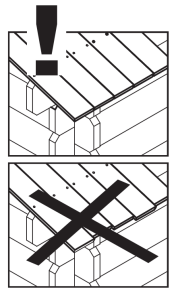
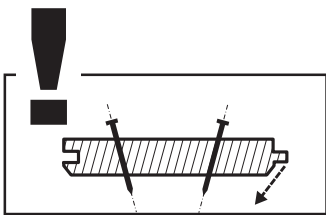
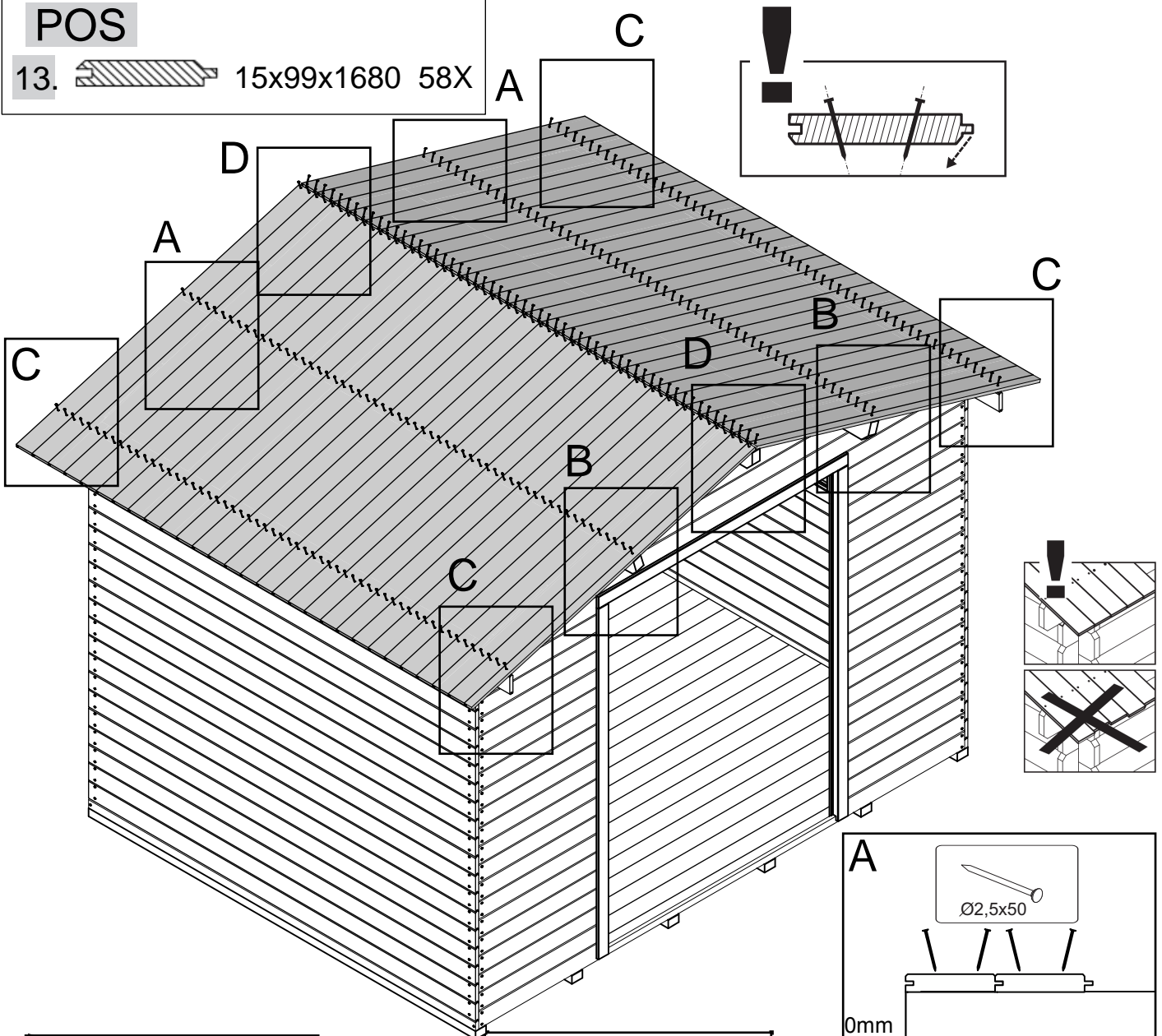

POS

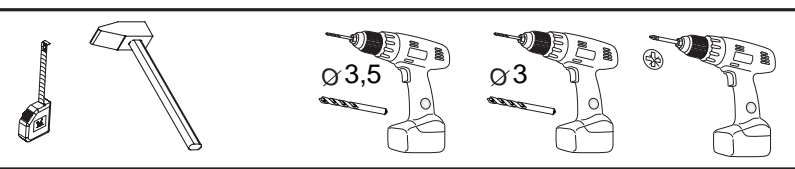

13.  15x99x1680 58X

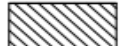

8

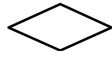

- POS**
- 14.  15x95x1730 4X
 - 15.  12x26x1740 4X
 - 17.  12x42x1290 4X

- 16.  2X
-  X24
3,5x25mm
-  X24
3,5x35mm

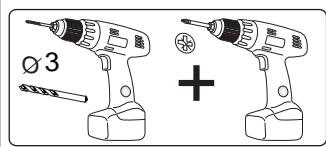
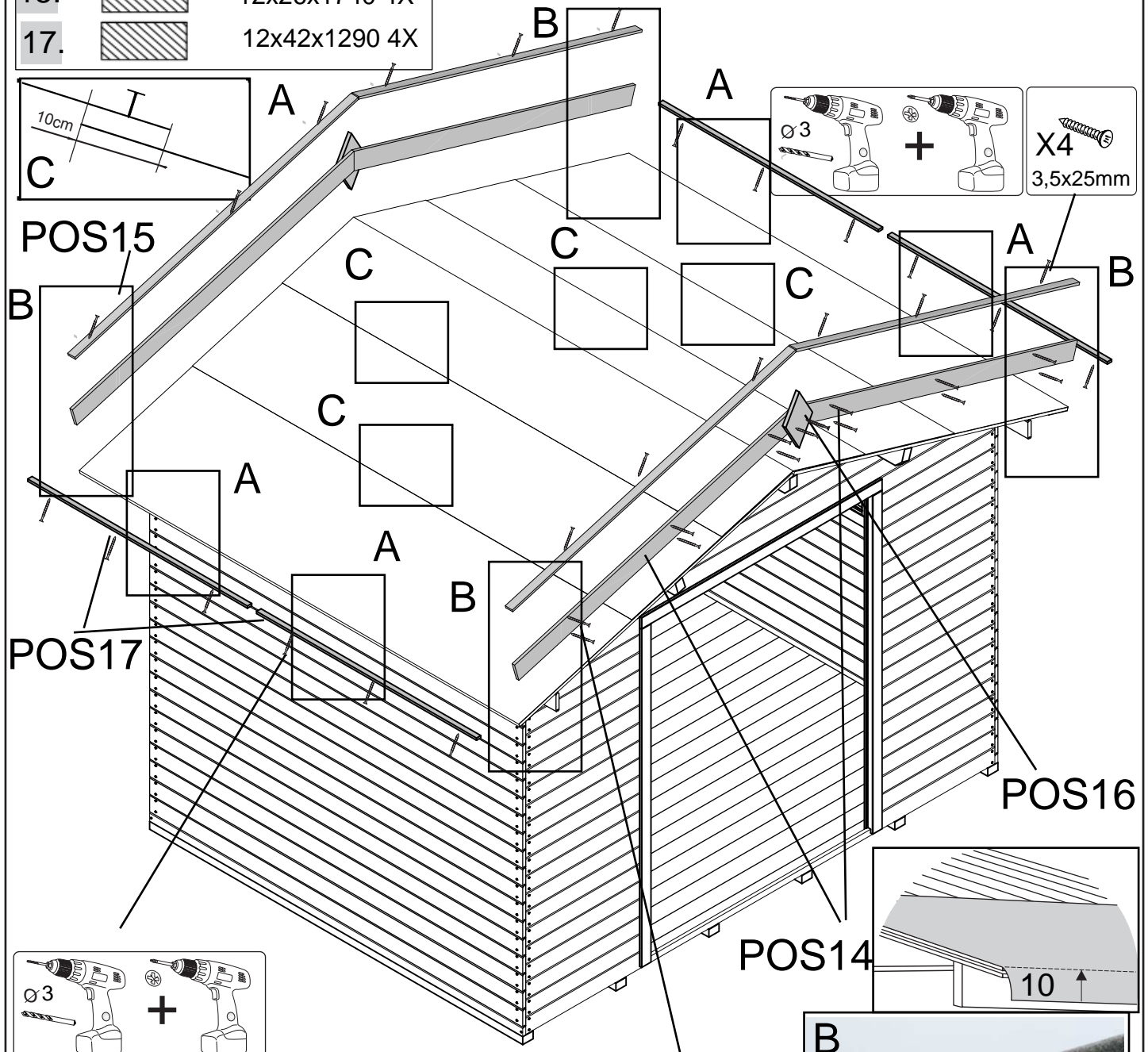

- X3
3,5x25mm

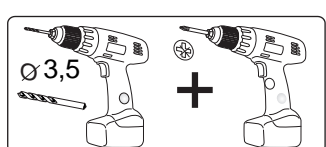

- X6
3,5x35mm

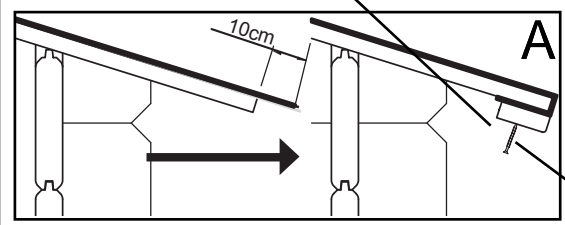

POS17

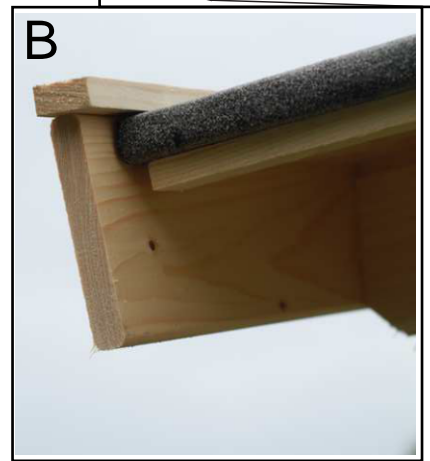

9



POS

- 18. 15x95x1750 4X
- 19. 15x70x1800 4X

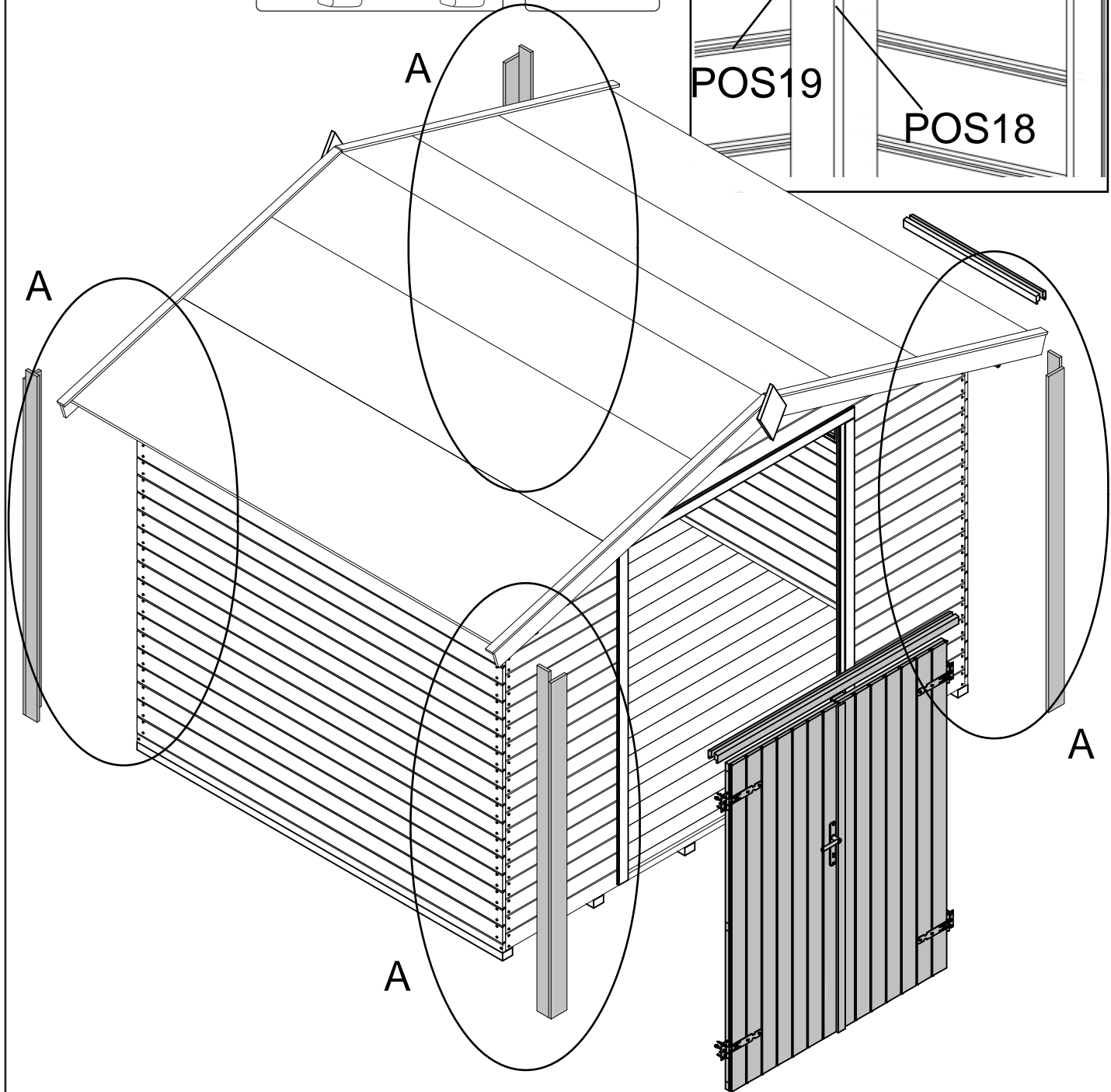
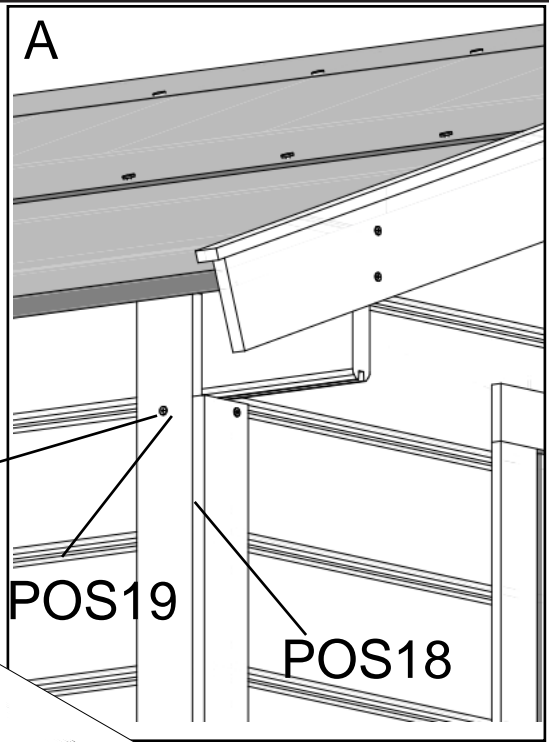
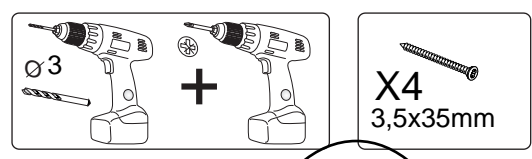
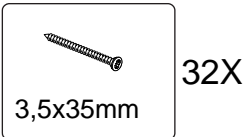

Kontrollskjema:**Ta vare på dette dokumentet!**

Produktet du har kjøpt, ble produsert i henhold til høye kvalitetskrav. Produktet har blitt kontrollert nøye og deretter omhyggelig pakket. For å unngå mulige problemer under monteringen, uansett om du gjør det selv eller får en godkjent håndverker til å gjøre det, anbefaler vi at du kontrollerer leveransen mot delelisten for å se om alle delene er inkludert. Denne kontrollen må gjøres innen 14 dager etter at delene ble levert til din adresse.

Garantikrav begrenser seg til bytte av defekte deler. Defekte elementer som allerede har blitt brukt eller malt/beiset/limt, vil ikke bli erstattet. Dersom du har en reklamasjon, vennligst gjør som følger:

- Fyll ut dette kontrollskjema med en forklaring av problemet og ønsket løsning
- Legg ved kopi av kjøpskvitteringen
- Send oversiktlige bilder som viser problemet

Lever/ send dette til salgsstedet. Bare når du har med disse dokumentene kan klagen behandles raskt og uten komplikasjoner.

Fabrikk kontroll utført av:	
Serienummer:	
Dato:	

Skal fylles ut av kunden:

Kjøpssted:	
Nr på kvittering og dato:	
Leveringsdato:	
Kundens adresse:	
Telefon:	

Reklamasjonsgrunn: