



Staple type: 17 Series Staples  
 Wire Ø: 1.51mm

**Suitable for the following tools:**

Duo-Fast SW17 48

Toolmatic S520.4805

*\*please check staple length compatibility with each tool before use*

Staple lengths available: 16mm – 38mm  
 Staples per strip: 63

**CORROSION PROTECTION**

Finish	Usage Environment	Label Colour on Packaging
Zinc Galv up to 3µm	INDOOR 	Blue

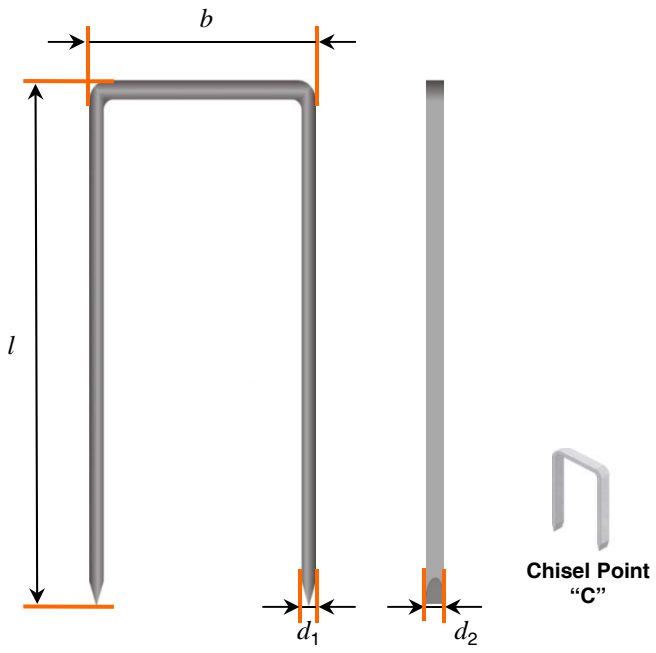

**STAPLE PROPERTIES / DIMENSIONS**

Tensile strength of wire:	min 850 N/mm <sup>2</sup>
Nominal diameter (d):	1.51mm
Flattened wire dimension:	(d <sub>1</sub> ): 1.29mm (d <sub>2</sub> ): 1.63mm
Outside crown width (b):	26.20mm
Strip length:	approx 103.00mm
Standard point:	“C”
Coated leg length:	Full

**STAPLE LENGTHS AVAILABLE\***

Finish	Lengths Available <small>*Other lengths on request</small>
Zinc Galv up to 3µm	16mm, 18mm, 25mm, 32mm, 38mm,

Duo-Fast is a brand of the ITW Group. ITW reserves the right to change specification without notice. All design using this data should be carried out by a qualified structural engineer, subject to relevant National and European standards or regulations.