

ENVIRONMENTAL PRODUCT DECLARATION

in accordance with ISO 14025, ISO 21930 and EN 15804

Owner of the declaration:	Leca International
Program operator:	The Norwegian EPD Foundation
Publisher:	The Norwegian EPD Foundation
Declaration number:	EPD-NOR-1742-715-EN
Registration number:	1742-715-EN
ECO Platform reference number:	EPD-NOR-1742-715-EN
Issue date:	01.01.2015
Valid to:	31.12.2016

Leca® ISO 10-20

Leca International



www.epd-norge.no



General information

Product:

Leca® ISO 10-20

Program operator:

The Norwegian EPD Foundation
 Pb. 5250 Majorstuen, 0303 Oslo
 Phone: +47 22 46 46 46
 e-mail: post@epd-norge.no

Declaration number:
ECO Platform reference number:
This declaration is based on Product Category Rules:

CEN Standard EN 15804:2012+A1:2013 serves as core PCR
 NPCR 012:2018 Part B for Thermal insulation products

Statement of liability:

The owner of the declaration shall be liable for the underlying information and evidence. EPD Norway shall not be liable with respect to manufacturer information, life cycle assessment data and evidences.

Declared unit:

1 m3 Leca® ISO 10-20

Declared unit with option:

A1,A2,A3,A4

Functional unit:
Verification:

Independent verification of data, other environmental information and the declaration according to ISO14025:2010, § 8.1.3 and § 8.1.4

External

Third party verifier:

Sign



Senior Research Scientist, Anne Rønning

(Independent verifier approved by EPD Norway)

Owner of the declaration:

Leca International
 Contact person: Tone Storbråten
 Phone: +47 41 43 71 00
 e-mail: info@leca.no

Manufacturer:

Leca International

Place of production:

Leca, Rælingen
 Årnesvegen 1
 N-2009 Nordby
 Norway

Management system:

ISO 14001 ISO 9001

Organisation no:

918 799 141

Issue date:

01.08.2017

Valid to:

31.07.2018

Year of study:

2017

Comparability:

EPD of construction products may not be comparable if they not comply with EN 15804 and seen in a building context.

Author of the Life Cycle Assessment:

The declaration is developed using eEPD v3.0 from LCA.no
 Approval:
 Company specific data are:

Collected/registered by: Tone Storbråten

Internal verification by: Jan Szanser

Approved:

Sign



Håkon Hauan
 Managing Director of EPD-Norway

Product

Product description:

Lightweight expanded clay aggregate is a granular ceramic material made from natural clay. The clay is mixed with organic material, dried and expanded to 3-4 times its original volume in rotary kilns at temperatures of about 1150 °C. The output lightweight expanded clay aggregate granules, in the range 0-32 mm, are sieved and blended into different grades of products and distributed in bulk or in bags.

Product specification

The EPD describes results for production of lightweight expanded clay aggregate, grading 8-20 mm, at Leca Rælingen. For calculations of environmental data for other types of Leca than ISO 10-20, densities from the table of different gradings should be used. The average annual production of lightweight expanded clay kiln material at Leca Rælingen has a weight of 0,30 ton/m³.

Materials	
Clay	97 - 100 %
Dolomite	1-3 %
Coating materials	< 1 %

Technical data:

The relevant technical properties for Leca® ISO 10-20 are provided below:

Technical property.....Test method.....Typical value
 Loose bulk density.....(NS-EN 1097-3).....245 kg/m³
 Grading.....(NS-EN 933-1).....8-20 mm
 Compressibility and confined compressive strength.....(NS-EN 13055-1)...0,8 MPa
 Thermal conductivity(NS-EN 14063-1)...0,107 W/mK,
 Reaction to fire.....(NS-EN 13820).....A1

Grading [mm]- Density [ton/m³]

0-32..... 0,28
 2-4..... 0,37
 4-10..... 0,29
 10-20..... 0,25
 Leca 800..... 0,80

Market:

Norway

Reference service life, product

Not relevant

Reference service life, building

Not relevant

LCA: Calculation rules

Declared unit:

1 m³ Leca® ISO 10-20

Cut-off criteria:

All major raw materials and all the essential energy is included. The production processes for raw materials and energy flows with very small amounts (less than 1%) are not included. These cut-off criteria do not apply for hazardous materials and substances.

Data quality:

Specific data for the product composition are provided by the manufacturer. They represent the production of the declared product and were collected for EPD development in the year of study. Background data is based on registered EPDs according to EN 15804, Ostfold Research databases, ecoinvent and other LCA databases. The data quality of the raw materials in A1 is presented in the table below.

Materials	Source	Data quality	Year
Coating materials	ecoinvent 3.4	Database	2017
Dolomite	ecoinvent 3.4	Database	2017
Oxygen	ecoinvent 3.4	Database	2017
Clay	Specific data	Database	2018

Allocation:

The allocation is made in accordance with the provisions of EN 15804. Incoming energy and water and waste production in-house is allocated equally among all products through mass allocation. Effects of primary production of recycled materials is allocated to the main product in which the material was used. The recycling process and transportation of the material is allocated to this analysis.

System boundary:

The system boundary of the EPD follows the modular structure in line with EN 15804. This section describes the modules which are contained within the scope of this study. As the scope of the assessment is up to the point at which the lightweight clay aggregate is manufactured modules A1- A4 have been considered in this LCA

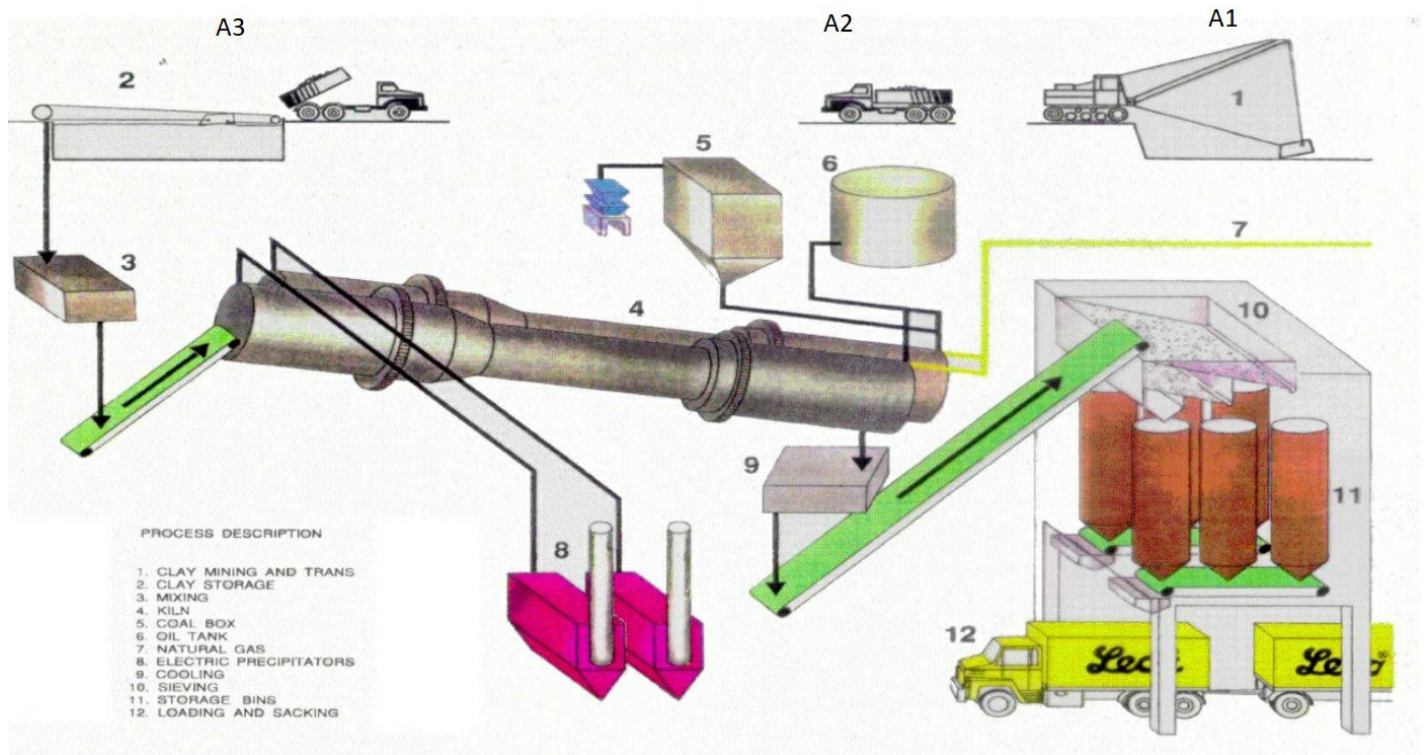

Additional technical information:

Leca® ISO 10-20 is a ceramic material with good resistance to frost, high temperatures and chemicals etc. Leca® ISO 10-20 has good insulation and drainage properties.

LCA: Scenarios and additional technical information

The following information describe the scenarios in the different modules of the EPD.

Transport from production place to user (A4)

Type	Capacity utilisation (incl. return) %	Type of vehicle	Distance km	Fuel/Energy consumption	Unit	Value (l/t)
Truck	55,0 %	Truck, lorry over 32 tonnes, EURO 6	300	0,022606	l/tkm	6,78
Railway					l/tkm	
Boat					l/tkm	
Other Transportation					l/tkm	

LCA: Results

System boundaries (X=included, MND=module not declared, MNR=module not relevant)

Product stage				Construction installation stage	User stage								End of life stage				Beyond the system boundaries
Raw materials	Transport	Manufacturing	Transport	Assembly	Use	Maintenance	Repair	Replacement	Refurbishment	Operational energy use	Operational water use	De-construction demolition	Transport	Waste processing	Disposal	Reuse-Recovery-Recycling-potential	
A1	A2	A3	A4	A5	B1	B2	B3	B4	B5	B6	B7	C1	C2	C3	C4	D	
X	X	X	X	MND	MND	MND	MND	MND	MND	MND	MND	MND	MND	MND	MND	MND	

Environmental impact

Parameter	Unit	A1	A2	A3	A4
GWP	kg CO ₂ -eq	3,32E+00	4,79E-01	5,77E+01	6,08E+00
ODP	kg CFC11 -eq	2,12E-07	9,00E-08	4,45E-07	1,25E-06
POCP	kg C ₂ H ₄ -eq	1,25E-03	8,50E-05	1,06E-02	9,52E-04
AP	kg SO ₂ -eq	1,36E-02	1,69E-03	1,83E-01	1,57E-02
EP	kg PO ₄ ³⁻ -eq	8,38E-03	3,51E-04	4,06E-02	3,32E-03
ADPM	kg Sb -eq	9,58E-06	1,05E-06	7,93E-06	1,45E-05
ADPE	MJ	4,00E+01	7,32E+00	4,74E+02	9,99E+01

GWP Global warming potential; ODP Depletion potential of the stratospheric ozone layer; POCP Formation potential of tropospheric photochemical oxidants; AP Acidification potential of land and water; EP Eutrophication potential; ADPM Abiotic depletion potential for non fossil resources; ADPE Abiotic depletion potential for fossil resources

Reading example: 9,0 E-03 = 9,0*10⁻³ = 0,009

*INA Indicator Not Assessed

Resource use

Parameter	Unit	A1	A2	A3	A4
RPEE	MJ	1,86E+01	1,13E-01	6,41E+01	1,82E+00
RPEM	MJ	0,00E+00	3,44E-02	0,00E+00	0,00E+00
TPE	MJ	1,86E+01	1,47E-01	6,41E+01	1,82E+00
NRPE	MJ	5,26E+01	7,47E+00	4,81E+02	1,03E+02
NRPM	MJ	0,00E+00	0,00E+00	0,00E+00	0,00E+00
TRPE	MJ	5,26E+01	7,47E+00	4,81E+02	1,03E+02
SM	kg	0,00E+00	0,00E+00	0,00E+00	0,00E+00
RSF	MJ	0,00E+00	0,00E+00	0,00E+00	0,00E+00
NRSF	MJ	0,00E+00	0,00E+00	3,42E+02	0,00E+00
W	m ³	1,73E-01	6,66E-03	6,60E-02	2,44E-02

RPEE Renewable primary energy resources used as energy carrier; RPEM Renewable primary energy resources used as raw materials; TPE Total use of renewable primary energy resources; NRPE Non renewable primary energy resources used as energy carrier; NRPM Non renewable primary energy resources used as materials; TRPE Total use of non renewable primary energy resources; SM Use of secondary materials; RSF Use of renewable secondary fuels; NRSF Use of non renewable secondary fuels; W Use of net fresh water

Reading example: 9,0 E-03 = $9,0 \cdot 10^{-3} = 0,009$

*INA Indicator Not Assessed

End of life - Waste

Parameter	Unit	A1	A2	A3	A4
HW	kg	4,76E-05	5,65E-06	3,48E-05	5,49E-05
NHW	kg	9,33E-01	7,40E-01	1,67E+01	9,41E+00
RW	kg	INA*	INA*	INA*	INA*

HW Hazardous waste disposed; NHW Non hazardous waste disposed; RW Radioactive waste disposed

Reading example: 9,0 E-03 = $9,0 \cdot 10^{-3} = 0,009$

*INA Indicator Not Assessed

End of life - Output flow

Parameter	Unit	A1	A2	A3	A4
CR	kg	0,00E+00	0,00E+00	0,00E+00	0,00E+00
MR	kg	0,00E+00	0,00E+00	3,10E-02	0,00E+00
MER	kg	0,00E+00	0,00E+00	0,00E+00	0,00E+00
EEE	MJ	INA*	INA*	INA*	INA*
ETE	MJ	INA*	INA*	INA*	INA*

CR Components for reuse; MR Materials for recycling; MER Materials for energy recovery; EEE Exported electric energy; ETE Exported thermal energy

Reading example: 9,0 E-03 = $9,0 \cdot 10^{-3} = 0,009$

*INA Indicator Not Assessed

Additional Norwegian requirements

Greenhouse gas emissions from the use of electricity in the manufacturing phase

National production mix from import, low voltage (production of transmission lines, in addition to direct emissions and losses in grid) of applied electricity for the manufacturing process (A3).

Electricity mix	Data source	Amount	Unit
Electricity, Norway (kWh)	ecoinvent 3.4 Alloc Rec	31,04	g CO2-ekv/kWh

Dangerous substances

The product contains no substances given by the REACH Candidate list or the Norwegian priority list.

Indoor environment

Bibliography

ISO 14025:2010 Environmental labels and declarations - Type III environmental declarations - Principles and procedures.

ISO 14044:2006 Environmental management - Life cycle assessment - Requirements and guidelines.

EN 15804:2012+A1:2013 Environmental product declaration - Core rules for the product category of construction products.

ISO 21930:2017 Sustainability in buildings and civil engineering works - Core rules for environmental product declarations of construction products.

ecoinvent v3, Alloc Rec, Swiss Centre of Life Cycle Inventories.

Iversen et al., (2018) eEPD v3.0 - Background information for EPD generator system. LCA.no Report number 04.18

NPCR Part A: Construction products and services. Ver. 1.0. April 2017.

NPCR 012:2018 Part B for Thermal insulation products

	Program operator and publisher The Norwegian EPD Foundation Post Box 5250 Majorstuen, 0303 Oslo 0303 Oslo Norway	Phone: +47 21 11 10 00 e-mail: post@epd-norge.no web: www.epd-norge.no
	Owner of the declaration Leca International Årnesvegen 1 2009 Nordby	Phone: +47 41 43 71 00 Fax: e-mail: info@leca.no web: www.leca.no
	Author of the Life Cycle Assessment Østfoldforskning AS Stadion 4 1671 Kråkerøy	Phone: +47 69 35 11 00 Fax: +47 69 34 24 94 e-mail: web: www.ostfoldforskning.no
	Developer of EPD generator LCA.no AS Dokka 1C 1671 Kråkerøy	Phone: +47 916 50 916 e-mail: post@lca.no web: www.lca.no