



ETA-Danmark A/S
Göteborg Plads 1
DK-2150 Nordhavn
Tel. +45 72 24 59 00
Fax +45 72 24 59 04
Internet www.etadanmark.dk

Authorised and notified according
to Article 29 of the Regulation (EU)
No 305/2011 of the European
Parliament and of the Council of 9
March 2011

MEMBER OF EOTA



European Technical Assessment ETA-04/0013 of 2019/11/12

I General Part

Technical Assessment Body issuing the ETA and designated according to Article 29 of the Regulation (EU) No 305/2011: ETA-Danmark A/S

Trade name of the construction product:

CNA Connector nails and CSA Connector screws

Product family to which the above construction product belongs:

Nails and screws for use in nailing plates in timber structures

Manufacturer:

Simpson Strong-Tie Int. Ltd
For local branch addresses refer to www.strongtie.eu

Manufacturing plant:

SIMPSON STRONG-TIE Manufacturing facilities

This European Technical Assessment contains:

11 pages including 2 annexes which form an integral part of the document

This European Technical Assessment is issued in accordance with Regulation (EU) No 305/2011, on the basis of:

EAD 130033-00-0603 - Nails and screws for use in nailing plates in timber structures, edition 2015-03

This version replaces:

The previous ETA with the same number issued on 2016-11-30

Translations of this European Technical Assessment in other languages shall fully correspond to the original issued document and should be identified as such.

Communication of this European Technical Assessment, including transmission by electronic means, shall be in full (excepted the confidential Annex(es) referred to above). However, partial reproduction may be made, with the written consent of the issuing Technical Assessment Body. Any partial reproduction has to be identified as such.

**Modifications and additions to the previous
ETA-04/0013 valid from 2008-08-13 to 2013-08-
13**

Pages	Update
4 and 10	4,0 mm CNA nails, length 35, 40, 50, 60 in stainless steel have been added
6	Overlapping nails in a three-member connection has been added
10	CNA3,1x50, CNA3,7x40 and CNA3,7x60 have been deleted
10	L for CNA4,0 mm has been added 1,5 mm except for CNA4,0x35
11, 12	Height of the screw head has been changed from 2,7 mm to min 2,3 mm
12	CSA5,0x50 is added
13	In table B2 $F_{lat,Rk}$ for CSA 5,0x35 has been reduced

**Modifications and additions to the previous
ETA-04/0013 valid from 2009-08-12 to 2014-08-
12**

Pages	Update
	Renewed

**Modifications and additions to the previous
ETA-04/0013 valid from 2013-06-29 to 2018-03-
11**

Pages	Update
3	Minimum length of CNA 4,0mm reduced to 30mm
3	Range of lengths of CSA screws increased to 25mm to 80mm
3	“Parallam” removed from timber range
4	Tensile capacity of 4,0mm screws added
4	Torsional strength of 4,0mm screws added
5	Formulae for determining lateral capacity modified to include k_1 factor and also can now applicable for use with screws
5	Yield moment properties for screws added
5	Withdrawal parameter for screws added
5	Table 3.1 added
6	Overlapping screws in a three-member connection has been added
6	Hole sizes for screws added
6	Rules for spacing and edge distances updated in line with Eurocode 5

8	New sizes of nails added to table
8	Drawing 1 – Nails, updated
9	New sizes of screws added
9	Drawing 2 – Screws updated
9	Materials grade for screws updated
10	New sizes and performance values added to tables
10	Characteristic capacities of screws updated in line with new method

**Modifications and additions to the previous
ETA-04/0013 valid from 2015-05-12**

Pages	Update
3	Stainless Steel added to materials for CSA Screws Text changes referring to Drawings in Annex A Text changes referring to use of stainless steel fasteners in Service Class 3
3	Addition of note referring to alternative coatings being used
6	Text changed regarding use of formulas to determine performance values for other timber grades
8	Text regarding No Equal Sign moved next to drawing Text regarding CNA Materials added from Page 9
9	Drawing updated to include all options for types of point Table updated to include Type 1 and Type 2 screws Table updated to include performance values for type 2 screws Text added detailing options for stainless steels that can be used to manufacture CSA Screws
11	Table update to include values for type 2 screws

Modifications and additions to the previous ETA-04/0013 valid from 30/11/2016	
Pages	Update
1, 5, 7, 8, 10, 12	4,2 mm PCR Nails deleted.
5	Hot Dip Galvanized (HDG) coating and Fe/ZnNi8/Cn/T2 (Impreg ^{®+}) coating added for use in Service Class 3.
5	Anti-friction coating added for screws and colored painted heads added for fasteners.
6	Tensile capacity for HDG Nails added.
6	f_{tor} changed into M_{tor}
6	Service Class 3 added in 3.8
7	Tensile strength for HDG added
7	Yield moment for Type 2 Screws corrected.
7	$d = d_{ef}$ added for screws
7	Modification for timber density added.
8	Regarding spacing for CSA, use the effective diameter added.
10	Head diameter for 4,0 mm CNA changed.
10	HDG coating added.
10, 11	Tolerances adjusted, drawings and abbreviations updated.
11	CSA5,0x30/45/55/60/65/70/75 added.
11	Fe/ZnNi8/Cn/T2 (Impreg ^{®+}) coating added.
12	Performance values for 290 kg/m ³ deleted and values for 420 and 460 kg/m ³ added.
12	$F_{lat,Rk}$ for CNA4,0x40 corrected.
13	Performance values for new sizes of CSA added.
13	Performance values for 290 kg/m ³ deleted and values for 420 and 460 kg/m ³ added.

II SPECIFIC PART OF THE EUROPEAN TECHNICAL ASSESSMENT

1 Technical description of product and intended use

Technical description of the product

CNA Connector nails are made from drawn non-alloy steel or austenitic stainless steel wire. The shank is cylindrical and made with annular ribs on part of the shank. The shank has a special conical part under the head. The nail head is cylindrical and the point is pyramid shaped in drawing 1, see Annex A

CSA Connector screws are made from drawn mild steel, carbon steel or drawn austenitic stainless steel wire and are threaded almost over the total length. The shank just below the head has a cylindrical and a conical part. The point can be any of the options shown in drawing 2, see Annex A. In the following, Type 1 refers to electroplated steel or the first set of stainless steel grades and Type 2 refers to a specific grade of stainless steel (1.4529).

The screws can be lubricated with an anti-friction coating.

The fasteners can be applied with a coloured paint on the head.

Range

The dimensions of the Connector Nails and Connector Screws are shown in Annex A

2 Specification of the intended use in accordance with the applicable EAD

The nails and screws are used in conjunction with 2D and 3D steel and aluminium nailing plates for connections in load bearing timber structures with members of solid timber, glued laminated timber and similar glued members or wood-based structural members, where requirements for mechanical resistance and stability and safety in use in the sense of the Basic Works Requirements 1 and 4 of Regulation (EU) 305/2011 shall be fulfilled.

Note: The requirement to the material of the wood members can be fulfilled by using the following materials:

- Solid timber classified to C14-C40 according to EN 338 / EN 14081
- Glued members of timber classified to C14 – C40

according to EN 338 / EN 14081.

- Glued laminated timber classified to GL24c or better according to EN 1194/EN 14080.
- Solid Wood Panels, SWP according to EN 13353.
- Laminated Veneer Lumber LVL according to EN 14374
- Plywood according to EN 636
- Oriented Strand Board, OSB according to EN 300

The design of the timber connections shall be based on the characteristic load-carrying capacities of the nails and screws. The design capacities shall be derived from the characteristic capacities in accordance with Eurocode 5 or a similar national Timber Code.

Electroplated fasteners (Fe/Zn) are for use in timber structures subject to dry, internal conditions defined by the service classes 1 and 2 of EN 1995-1-1:2014, (Eurocode 5).

Stainless steel fasteners, Hot Dip Galvanized (HDG) Nails and Fe/ZnNi8/Cn/T2 (Impreg[®]+) coated Screws are for use in timber structures subjected to dry, internal conditions defined by the service classes 1 and 2 of EN 1995-1-1:2004 (Eurocode 5) and also for outdoor conditions defined by the service class 3 of EN 1995-1-1:2014, (Eurocode 5).

The scope of the nails and screws regarding resistance to corrosion shall be defined according to national provisions that apply at the installation site considering environmental conditions.

Alternative coatings may be used, provided it has been documented that the corrosion protection is at least equivalent to the specification listed within this document. Such alternative coatings will be specified in annex A.

The provisions made in this European Technical Assessment are based on an assumed intended working life of the Connector Nails and Connector Screws of 50 years.

The indications given on the working life cannot be interpreted as a guarantee given by the producer or Assessment Body, but are to be regarded only as a means for choosing the right products in relation to the expected economically reasonable working life of the works.

3 Performance of the product and references to the methods used for its assessment

Characteristic	Assessment of characteristic
3.1 Mechanical resistance and stability*) (BWR1)	
Withdrawal and lateral load-carrying capacity	See Annex B
Tensile capacity	Nails: <ul style="list-style-type: none"> 3,1 mm: 4,5 kN 3,7 mm: 6,5 kN 4,0 mm: 7,5 kN 6,0 mm: 17,0 kN Nails (HDG): <ul style="list-style-type: none"> 4,0 mm: 6,5 kN Screws (Type 1): <ul style="list-style-type: none"> 4,0 mm: Min 6,0 kN 5,0 mm: Min 6,8 kN Screws (Type 2): <ul style="list-style-type: none"> 5,0 mm: Min 5,3 kN
Torsional strength of screws (Type 1 and 2) (5-percentile values)	4,0 mm: Characteristic value: $M_{tor,Rk} \geq 3,5 \text{ Nm}$ 5,0 mm: Characteristic value: $M_{tor,Rk} \geq 4,9 \text{ Nm}$ $M_{tor,Rk} \geq 1,5 M_{tor,Em}$
3.2 Safety in case of fire (BWR2)	
Reaction to fire	The nails and screws are made from steel classified as Euroclass A1 in accordance with EN 1350-1 and EC decision 96/603/EC, amended by EC Decision 2000/605/EC
3.3 Hygiene, health and the environment (BWR3)	
Influence on air quality	The product does not contain/release dangerous substances specified in TR 034, dated March 2012 (**))
3.8 General aspects related to the performance of the product	
Identification	See Annex A

*) See additional information in section 3.9 – 3.11.

**)) In addition to the specific clauses relating to dangerous substances contained in this European Technical Assessment, there may be other requirements applicable to the products falling within its scope (e.g. transposed European legislation and national laws, regulations and administrative provisions). In order to meet the provisions of the Construction Products Regulation, these requirements need also to be complied with, when and where they apply.

3.9 Mechanical resistance and stability

The load-carrying capacities for CNA Connector nails and CSA Connector screws are applicable to the wooden materials mentioned in clause 1 for intended use. The term timber has been used in the following meaning all materials mentioned under intended use.

The formulas for the load-carrying capacities are restricted to characteristic densities of the wooden materials up to 460 kg/m³. Even though the wood based material may have a larger density, this must not be used in the formulas.

The formulas are applicable to connections with metal plates manufactured from steel or aluminium.

3.9.1 Lateral capacity

The characteristic lateral load-carrying capacity of CNA Connector Nails and CSA Connector Screws, with plate thicknesses shown in the following table, shall be calculated from:

$$F_{lat,Rk} = F_{v,Rk} + (k_1 F_{ax,Rk})$$

Table 3.1 Thickness of plates

Product Type	Diameter [mm]	Steel Plates	Aluminium Plates
		Min. [mm]	Min. [mm]
Connector Nail	4,0 or less	1,0	2,0
	6,0	2,0	2,0
Connector Screw	5,0 or less	1,0	2,0

Where:

$F_{v,Rk}$ is the lateral dowel capacity per nail assuming a thick metal plate in N.

$$F_{v,Rk} = \min \left\{ \begin{array}{l} f_{h,k} t_1 d \quad (c) \\ f_{h,k} t_1 d \left[\sqrt{2 + \frac{4 M_{y,Rk}}{f_{h,k} d t_1^2}} - 1 \right] \quad (d) \\ 2,3 \sqrt{M_{y,Rk} f_{h,k} d} \quad (e) \end{array} \right.$$

$f_{h,k}$ is the characteristic embedment strength in the timber member in N/mm²;

$$f_{h,k} = 0,082 \rho_k d^{0,3}$$

ρ_k is the characteristic density of the timber in kg/m³

t_1 is the minimum of timber thickness or penetration in mm;

d is the fastener diameter in mm;

k_1 is the rope contribution factor;
0,6 for CNA Connector Nails
0,4 for CSA Connector Screws

$M_{y,Rk}$ is the characteristic fastener yield moment in Nmm;

$$\text{Nails; } M_{y,Rk} = 180 d^{2,6}$$

where the tensile strength of the wire for the nails is a minimum of 600 N/mm² and 580 N/mm² for HDG.

Screws (Type 1);

$$4,0 \text{ mm } M_{y,Rk} = 3500 \text{ Nmm}$$

$$5,0 \text{ mm } M_{y,Rk} = 5000 \text{ Nmm}$$

Screws (Type 2);

$$5,0 \text{ mm } M_{y,Rk} = 4660 \text{ Nmm}$$

3.9.2 Axial withdrawal capacity

The characteristic axial withdrawal capacity in N, shall be calculated from:

$$F_{ax,Rk} = f_{ax,k} d l_g$$

Where:

$f_{ax,k}$ is the characteristic withdrawal parameter in N/mm²

Nails:

$$f_{ax,k} = \min \left\{ \begin{array}{l} 6,125 \left(1 + \frac{1,5 d}{l_g} \right) \left(\frac{\rho_k}{350} \right) \\ (10,92 - 0,0158 d - 0,0968 l_g) \left(\frac{\rho_k}{320} \right)^2 \end{array} \right.$$

d Nominal diameter of the fastener in mm, for screws $d = d_{ef}$ acc. to EN1995-1-1, 8.7.1
 l_g the threaded length in the point side member in mm.

ρ_k characteristic density of the timber member in kg/m³

Screws; 4,0 mm: $f_{ax,k} = 13,8 (\rho_k/350)^{0,8}$ N/mm²
5,0 mm: $f_{ax,k} = 15,0 (\rho_k/350)^{0,8}$ N/mm²

Values for timber grades listed in section 2 can be determined using the formulas above.

For the relevant fastener sizes and timber densities Annex B states the characteristic load-carrying capacities.

3.10 Aspects related to the performance of the product

3.10.1 Corrosion protection in service class 1, 2 and 3. Annex A provides for the steel qualities and corrosion protection of the nails and screws.

3.10.2 Three-member connections.

CNA Connector nails with a diameter less than or equal to 4,2 mm may overlap in the central member provided $(t-t_2)$ is greater than or equal to $2,9d$, see figure below.

CSA Connector screws with a diameter less than or equal to 5,0 mm may overlap in the central member provided $(t-t_2)$ is greater than or equal to $4,0d$, see figure below

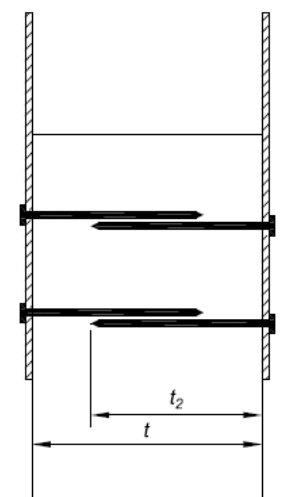

Figure 3.1 Geometry for overlapping fasteners. t : timber thickness, t_2 : point side penetration depth

3.11 General aspects related to the fitness for use of the product

The nails and screws are manufactured in accordance with the provisions of this European Technical Assessment using the manufacturing processes as identified in the inspection of the plant by the notified inspection body and laid down in the technical documentation.

The nails shall be driven into the wood by a hammer or a similar tool. The requirements for the holes in the metal plate depending on the diameter, d , of the nail is given in table 3.2

Nail diameter d [mm]	Min. hole diameter $d_{f,min}$ [mm]	Max. hole diameter $d_{f,max}$ [mm]
3,1	3,4	4,0
3,7	4,1	4,7
4,0	4,4	5,0
6,0	6,5	7,5

Table 3.2 Minimum and maximum diameter d_f of the holes in the metal plate depending on the diameter d , of the nails

The screws shall be screwed into the wood by a screwdriver or a screwing machine without pre drilling. The holes in the metal plate shall have a nominal diameter of 4,0 mm for 4,0 mm screws and 5,0 mm for 5,0 mm screws.

The CSA screws are to be installed using a non-impact driver to avoid high torques in excess of the torsional capacity

Minimum spacing and distances for CNA Connector Nails shall be determined in accordance with Eurocode 5, using the nominal diameter (d), unless predetermined by the connector being installed.

Minimum spacing and distances for CSA Connector Screws shall be determined in accordance with Eurocode 5, using the effective diameter (d_{ef}), unless predetermined by the connector being installed.

4 Attestation and verification of constancy of performance (AVCP)

4.1 AVCP system

According to the decision 97/638/EC of the European Commission¹, as amended, the system(s) of assessment and verification of constancy of performance (see Annex V to Regulation (EU) No 305/2011) is 2+.

5 Technical details necessary for the implementation of the AVCP system, as foreseen in the applicable EAD

Technical details necessary for the implementation of the AVCP system are laid down in the control plan deposited at ETA-Danmark prior to CE marking

Issued in Copenhagen on 2019-11-12 by



Thomas Bruun
Managing Director, ETA-Danmark

Annex A - Drawings and dimensions with tolerances

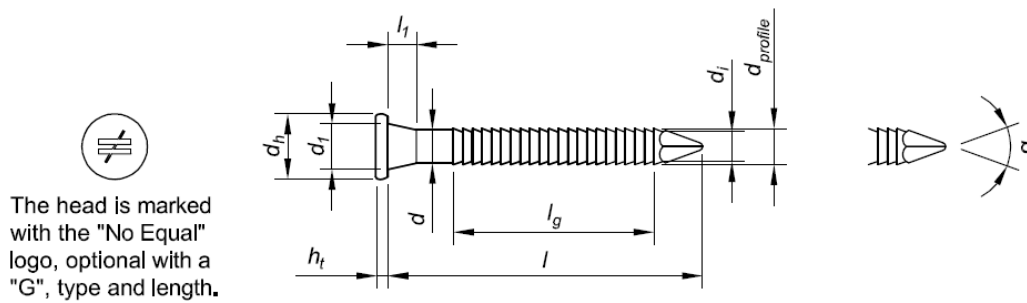

Drawing 1: CNA Connector nails

Tolerances are as follows:

- Length, l : $\pm 2,5 \%$
- Profiled length ex. point, l_g : $\pm 5 \%$
- Diameters, d, d_i : $\pm 2,5 \%$
- Diameter, $d_{profile} < 4 \text{ mm}$: $-0,1 / +0,2 \text{ mm}$
- Diameter, $d_{profile} \geq 4 \text{ mm}$: $\pm 2,5 \%$
- Head diameter, d_h : $\pm 5 \%$
- All other dimensions: $\pm 5 \%$

Connector Nail	Type ^{**)}	l	l_g	l_1	d	d_i	$d_{profile}$	d_h	d_1	h_t	$d_{profile} - d_i$	α
CNA3,1x40	1	40	25,4	2,1	3,1	2,7	3,4	6,2	4,6	1,0	0,7	40°
CNA3,1x60	1	60	45,4	2,1	3,1	2,7	3,4	6,2	4,6	1,0	0,7	40°
CNA3,7x50	1	50	34,5	2,3	3,7	3,3	4,1	7,4	5,4	1,4	0,8	40°
CNA4,0x35	1	33,5	20	3,5	4,0	3,6	4,4	7,0/8,0 ^{*)}	5,6	1,5	0,8	40°
	2	35	19	3,5	4,0	3,6	4,4	7,0/8,0 ^{*)}	5,6	1,5	0,8	40°
CNA4,0x40	1	38,5	25	3,5	4,0	3,6	4,4	7,0/8,0 ^{*)}	5,6	1,5	0,8	40°
	2	40	24	3,5	4,0	3,6	4,4	7,0/8,0 ^{*)}	5,6	1,5	0,8	40°
CNA4,0x50	1	48,5	35	3,5	4,0	3,6	4,4	7,0/8,0 ^{*)}	5,6	1,5	0,8	40°
	2	50	34	3,5	4,0	3,6	4,4	7,0/8,0 ^{*)}	5,6	1,5	0,8	40°
CNA4,0x60	1	58,5	45	3,5	4,0	3,6	4,4	7,0/8,0 ^{*)}	5,6	1,5	0,8	40°
	2	60	44	3,5	4,0	3,6	4,4	7,0/8,0 ^{*)}	5,6	1,5	0,8	40°
CNA4,0x75	1	75	59	3,5	4,0	3,6	4,4	7,0/8,0 ^{*)}	5,6	1,5	0,8	40°
CNA4,0x100	1	100	64	3,5	4,0	3,6	4,4	7,0/8,0 ^{*)}	5,6	1,5	0,8	40°
CNA6,0x60	1	60	41	2,7	6,0	5,5	6,5	12,0	8,0	2,0	1,0	40°
CNA6,0x80	1	80	61	2,7	6,0	5,5	6,5	12,0	8,0	2,0	1,0	40°
CNA6,0x100	1	100	61	2,7	6,0	5,5	6,5	12,0	8,0	2,0	1,0	40°

*) The head diameter can either be 7,0 or 8,0 mm

***) Type 1 and 2 refers to a different set of geometry

CNA Connector Nails manufactured from drawn non-alloy steel in accordance with EN 10016 (all parts), EN ISO 16120 (all parts) or ASTM A510-03, minimum characteristic tensile strength of the wire of 600 N/mm² (580 N/mm² for HDG) and are electroplated Fe/Zn12/A or equivalent in accordance with Table 1 of ISO 2081 or Hot Dip Galvanized with 50 μm Zinc according to EN ISO 1461.

CNA Connector Nails can also be manufactured from stainless steel wire number 1.4401, 1.4404 or 1.4571 in accordance with EN 10088-3:2006 or AISI 316, AISI 316L or 316Ti in accordance with ASTM A493-95 with minimum characteristic tensile strength of the wire of 600 N/mm²

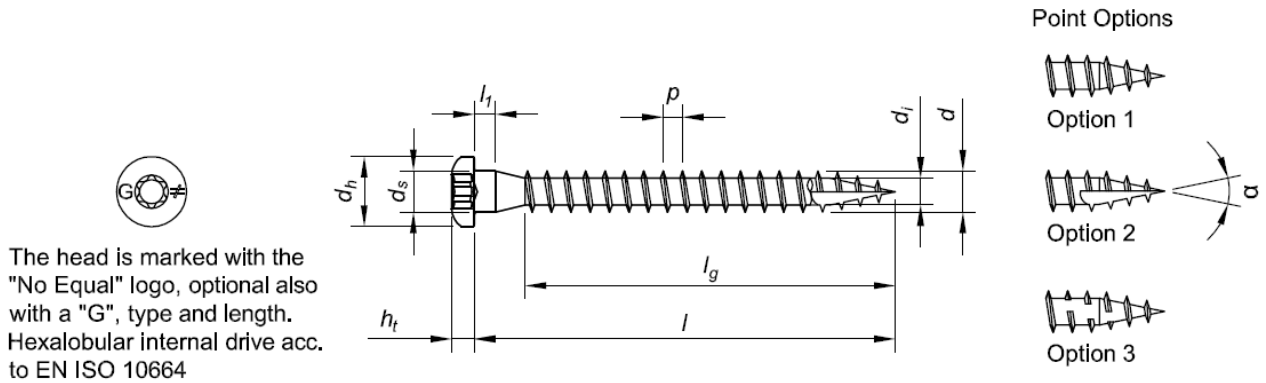

Drawing 2: CSA Connector screw

Tolerances are as follows:

- Lengths, l, l_g : $\pm 50 / (l^{0,6}) \%$
- Diameters, $d, d_i, d_s, d_l < 6 \text{ mm}$: $\pm 0,3 \text{ mm}$
- Diameters, $d, d_i, d_s, d_l \geq 6 \text{ mm}$: $\pm 5 \%$
- Head diameter, d_h : $\pm 5 \%$
- All other dimensions: $\pm 5 \%$

Connector Screw	Type*)	l	l_g	l_t	d	d_i	d_s	d_h	h_t	p	α
CSA4,0x30	1	30	24	2,5	3,85	2,5	3,83	7,3	2,0	1,6	23°
CSA5,0x25	1	25	19	2,5	4,85	3,15	4,9	8,3	2,3-2,7	2,3	23°
CSA5,0x30	1	30	24	2,5	4,85	3,15	4,9	8,3	2,3-2,7	2,3	23°
CSA5,0x35	1	35	29	2,5	4,85	3,15	4,9	8,3	2,3-2,7	2,3	23°
CSA5,0x40	1	40	34	2,5	4,85	3,15	4,9	8,3	2,3-2,7	2,3	23°
	2	40	35,2	2,5	4,85	3,0	4,9	8,3	2,3-2,7	2,3	23°
CSA5,0x45	1	45	39	2,5	4,85	3,15	4,9	8,3	2,3-2,7	2,3	23°
CSA5,0x50	1	50	44	2,5	4,85	3,15	4,9	8,3	2,3-2,7	2,3	23°
CSA5,0x55	1	55	49	2,5	4,85	3,15	4,9	8,3	2,3-2,7	2,3	23°
CSA5,0x60	1	60	54	2,5	4,85	3,15	4,9	8,3	2,3-2,7	2,3	23°
CSA5,0x65	1	65	49	2,5	4,85	3,15	4,9	8,3	2,3-2,7	2,3	23°
CSA5,0x70	1	70	64	2,5	4,85	3,15	4,9	8,3	2,3-2,7	2,3	23°
CSA5,0x75	1	75	69	2,5	4,85	3,15	4,9	8,3	2,3-2,7	2,3	23°
CSA5,0x80	1	80	74	2,5	4,85	3,15	4,9	8,3	2,3-2,7	2,3	23°

*) Type 1 and 2 refers to a different set of geometry

CSA Connector Screws are manufactured from drawn mild or carbon steel in accordance with EN 16120-2, minimum grade C18D or ASTM A510-03, minimum grade AISI 1018 and are electroplated Fe/Zn12/A or equivalent in accordance with Table 1 of ISO 2081 or /FeZnNi8/Cn/T2 (Impreg[®]+) coated according to EN ISO 4042:2018.

CSA Connector Screws can also be manufactured from stainless steel wire number 1.4401, 1.4404 or 1.4571 (Type 1) in accordance with EN 10088-3:2014 or number 1.4529 (Type 2) in accordance with EN10088-5:2011 or AISI 316, AISI 316L or 316Ti (Type 1) in accordance with ASTM A493-95.

Annex B - Characteristic capacities

Table B1: Characteristic capacities of CNA Connector nails for a characteristic density of the wood members as indicated in the table and a steel thickness of 2,0 mm. The fastener shall be driven completely into the wood or wood based material, which shall have a thickness of at least the length of the fastener. The performance of intermediate sizes or densities can be determined using the same methods stated in section 3 of this document.

Connector Nails	Density									
	320 kg/m ³		350 kg/m ³		380 kg/m ³		420 kg/m ³		460 kg/m ³	
	$F_{ax,Rk}$	$F_{lat,Rk}$	$F_{ax,Rk}$	$F_{lat,Rk}$	$F_{ax,Rk}$	$F_{lat,Rk}$	$F_{ax,Rk}$	$F_{lat,Rk}$	$F_{ax,Rk}$	$F_{lat,Rk}$
	[N]	[N]	[N]	[N]	[N]	[N]	[N]	[N]	[N]	[N]
CNA3,1x40	520	1330	570	1410	620	1490	680	1580	750	1670
CNA3,1x60	870	1540	950	1640	1030	1730	1140	1850	1250	1970
CNA3,7x50	830	1870	910	1980	980	2080	1090	2220	1190	2360
CNA4,0x35	560	1540	610	1660	670	1770	740	1930	810	2090
CNA4,0x40	670	1710	740	1850	800	1990	880	2170	970	2350
CNA4,0x50	900	2070	980	2220	1060	2330	1180	2490	1290	2640
CNA4,0x60	1120	2230	1230	2360	1330	2490	1470	2670	1610	2830
CNA4,0x75	1210	2290	1450	2500	1710	2720	1910	2930	2090	3120
CNA4,0x100	1190	2270	1430	2480	1680	2710	2060	3020	2250	3220
CNA6,0x60	1680	3670	1840	3970	2000	4270	2210	4680	2420	5080
CNA6,0x80	1800	4120	2150	4470	2540	4840	3090	5330	3380	5670
CNA6,0x100	1800	4120	2150	4470	2540	4840	3090	5330	3380	5670

The performance values for CNA4,0x35, CNA4,0x40, CNA4,0x50 and CNA4,0x60 are applicable for types 1 and 2. See page 10 for full details. Detailed calculation can be done by using the formulas on page 7. These performance values are applicable for Carbon Steel or Stainless Steel versions of the nails.

Table B2: Characteristic capacities of CSA Connector screws for a characteristic density of the wood members as indicated in the table and a steel thickness of 2,0 mm. The fastener shall be driven completely into the wood or wood based material, which shall have a thickness of at least the length of the fastener. The performance of intermediate sizes can be determined using the same methods stated in section 3 of this document.

Connector Screws	Type	Density									
		320 kg/m ³		350 kg/m ³		380 kg/m ³		420 kg/m ³		460 kg/m ³	
		$F_{ax,Rk}$	$F_{lat,Rk}$	$F_{ax,Rk}$	$F_{lat,Rk}$	$F_{ax,Rk}$	$F_{lat,Rk}$	$F_{ax,Rk}$	$F_{lat,Rk}$	$F_{ax,Rk}$	$F_{lat,Rk}$
		[N]	[N]	[N]	[N]	[N]	[N]	[N]	[N]	[N]	[N]
CSA4,0x30	1	1190	1260	1280	1360	1360	1450	1480	1570	1590	1690
CSA5,0x25	1	1290	1400	1380	1490	1480	1590	1600	1710	1720	1840
CSA5,0x30	1	1630	1620	1750	1730	1860	1850	2020	2000	2170	2160
CSA5,0x35	1	1960	1850	2110	1990	2250	2130	2440	2310	2630	2490
CSA5,0x40	1	2300	2090	2470	2250	2640	2410	2860	2620	3080	2770
	2	2380	2060	2560	2220	2730	2370	2960	2520	3190	2680
CSA5,0x45	1	2640	2330	2840	2480	3030	2610	3280	2790	3530	2960
CSA5,0x50	1	2980	2480	3200	2630	3420	2770	3700	2960	3980	3140
CSA5,0x55	1	3320	2610	3560	2770	3810	2930	4120	3120	4440	3320
CSA5,0x60	1	3660	2750	3930	2920	4200	3080	4550	3290	4890	3500
CSA5,0x65	1	4000	2890	4290	3060	4580	3240	4970	3460	5340	3680
CSA5,0x70	1	4330	3020	4660	3210	4970	3390	5390	3630	5790	3860
CSA5,0x75	1	4670	3160	5020	3350	5360	3550	5810	3800	6250	4040
CSA5,0x80	1	5010	3290	5380	3500	5750	3700	6230	3970	6700	4220

These performance values are applicable for Carbon Steel or Stainless Steel versions of the screws. Detailed calculation can be done by using the formulas on page 7.