

- SE MONTERINGSANVISNING TVÄTTSTÄLL
- DK MONTERINGSVEJLEDNING HÅNDVASK
- NO MONTERINGSANVISNING SERVANT
- FI PESUALLAS ASENNUSOHJEET
- GB INSTALLATION INSTRUCTIONS WASHBASIN
- EE PAIGALDUSJUHISED VALAMUTELE
- LV UZSTĀDĪŠANAS INSTRUKCIJA IZLIETNĒM
- LT PRAUSTUVO MONTAVIMO INSTRUKCIJA
- RU Инструкция по монтажу раковины

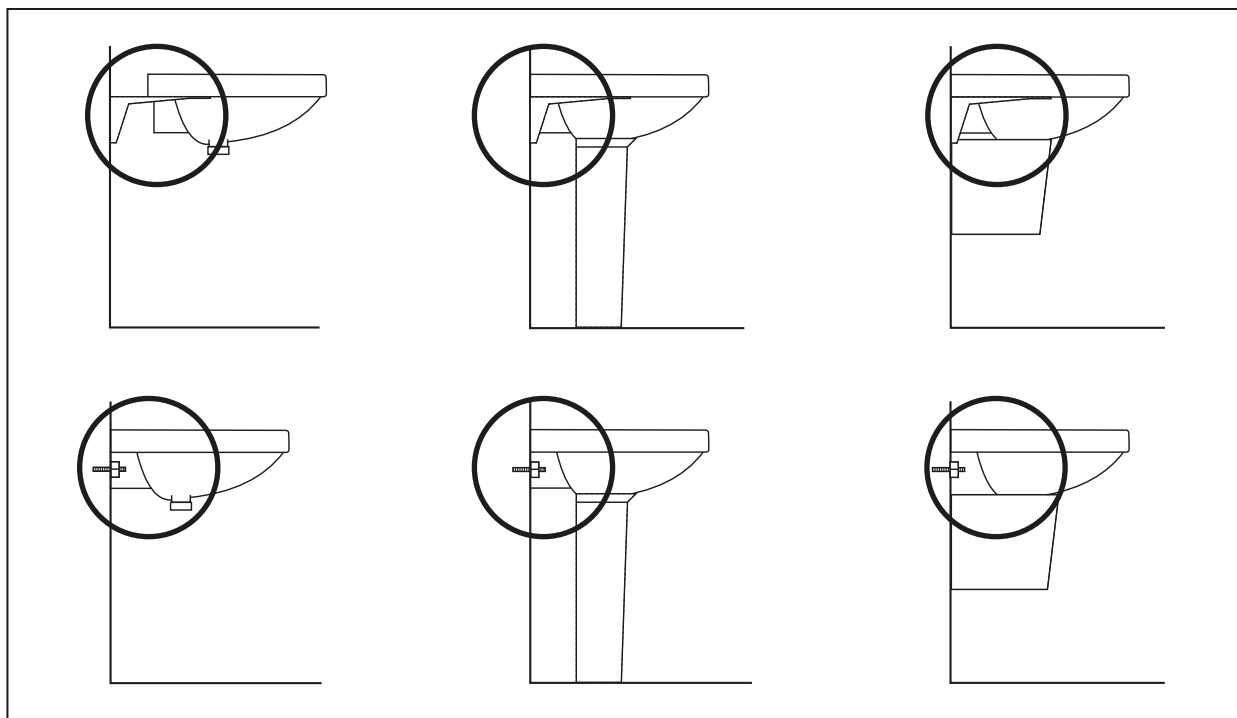
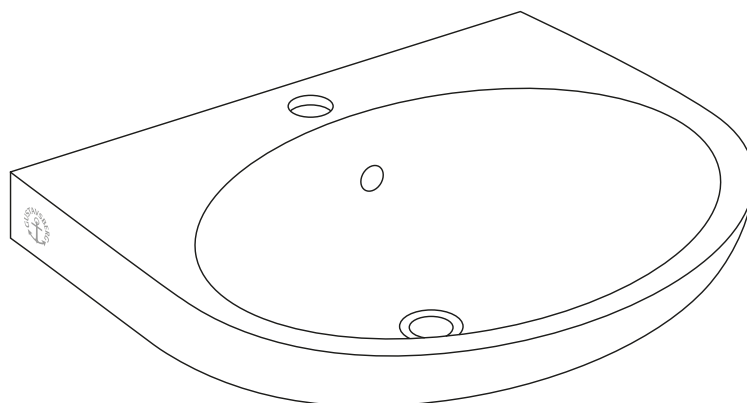

Accepterad
monteringsanvisning
2021:1

SE GARANTI

Produkten har garanti enligt respektive lands gällande branschvillkor.

Direktiv vid reklamation

Våra produkter är tillverkade enligt väldigt stränga kvalitetskrav. Om en produkt trots det är felaktig, ber vi er i första hand att kontakta din återförsäljare. Ärendet underlättas genom att uppvisa kvitto och uppge produktnummer och inköpsdatum.

DK GARANTI

Produktet har garanti i forhold til gældende dansk lovgivning.

Vejledning ved reklamation

Vores produkter er fremstillet i overensstemmelse med markedets strengeste krav til kvalitet. Skulle produktet mod forventning være behæftet med fejl henviser vi til den forhandler, hvor produktet er købt. Kvittering skal kunne fremvises, hvis forhandleren forlanger det, ligesom oplysninger om produktnummer og købsdato skal kunne dokumenteres.

NO GARANTI

Produktene har garanti i henhold til respektive lands gjeldende bransjevilkår.

Instrukser ved reklamasjon

Våre produkter er produsert i henhold til veldig strenge kvalitetskrav. Om et produkt til tross for dette skulle være feilaktig, ber vi deg vennligst ta kontakt med forhandleren. Vi ber deg medbringe kvittering og oppgi innkjøpsdato samt produktnummer.

FI TAKUU

Noudatamme alamme yleisiä toimitusehtoja.

Reklamaatio

Tuotteemme ovat valmistettu Villeroy & Boch ja Gustavsbergin laatuvaatimuksien mukaisesti. Mikäli tuote kuitenkin on virheellinen pyydämme teitä kääntymään ensisijaisesti tuotteen myyjän puoleen. Käsittelyn helpottamiseksi säilyttäkää tosite tuotteen ostosta.

GB GUARANTEE

The product has a guarantee accordingly to industry rules in every country.

Instructions for complaints

Our products are made according to very strict quality demands. If the product is faulty in spite of that we ask you kindly to take it to your reatailer. We also ask you to bring the receipt and be prepared to inform about the product number and purchasing date.

EE GARANTII

Antud tootel on garantii vastavalt tehase poolt kehtestatud tingimustele.

Juhised reklamatsioonide käsitlemiseks

Meie tooted on valmistatud silmas pidades väga täpseid kvaliteedistandardeid. Juhul kui olete saanud praaktoote, palume Teil toimetada see kas meie edasimüüja juurde või võtta ühendust esindusega. Samuti palume alles hoida ostutšekk ning vajadusel anda informatsiooni tootenumbri ja ostu sooritamise aja kohta.

LV GARANTIJA

Izstrādājumam ir garantija saskaņā ar ražotāja standartiem.

Instrukcija kvalitātes problēmu gadījumā

Mūsu produkcija tiek ražota pēc ļoti striktiem kvalitātes kritērijiem. Taču – gadījumā, ja produktam tiek konstatēta kvalitātes problēma – lūdzu, sazinieties ar pārdevēju. Lūdzu, esiet gatavi arī uzrādīt pirkuma čeku ar pirkuma datumu.

LT GARANTIJA

Gaminiams garantija suteikiama atsižvelgiant į konkrečios šalies kokybės reikalavimus.

Reklamacijos

Mūsų produkcija pagaminta vadovaujantis griežtais kokybės reikalavimais. Jei gaminys nekokybiškas – prašome jį gražinti pardavėjui, pateikiant pirkimo čekį, gaminio numerį bei nurodant pirkimo datą.

RU ГАРАНТИЯ

Гарантийные условия устанавливаются в соответствии с законами и правилами, которые действуют в стране сбыта.

Рассмотрение рекламаций

Наша продукция соответствует современным стандартам и требованиям к качеству. В случае возникновения неисправности Вы можете обратиться в торговую организацию, где было приобретено данное изделие. При заявлении рекламации необходимо предъявить сопроводительные документы к данной продукции и чек, подтверждающий дату покупки.

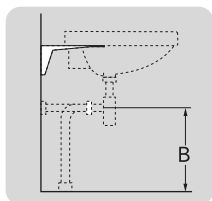

	B
SE	500 mm
FI	500 mm
NO	570 mm
DK	550 mm

* SE. Enligt Branschregler, Säker vatteninstallation

Infästning och tätning ska ske enligt Branschregler Säker Vatteninstallation.

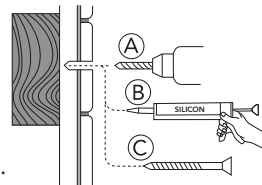

** SILICON
EN 15651-3. Class XS1
Ø5mm

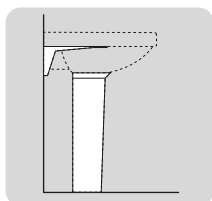
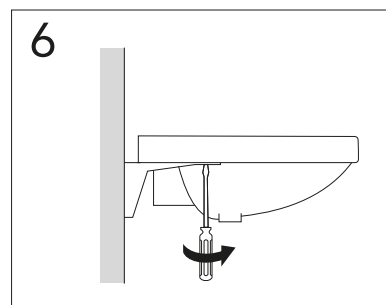
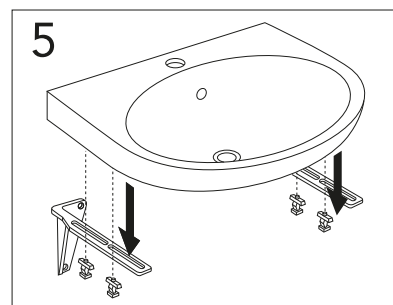
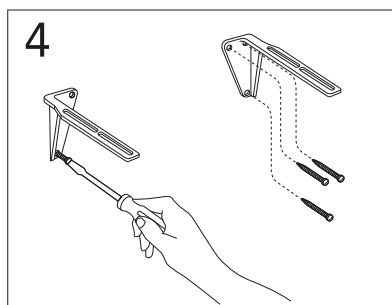
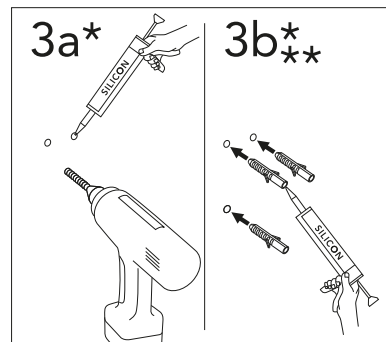
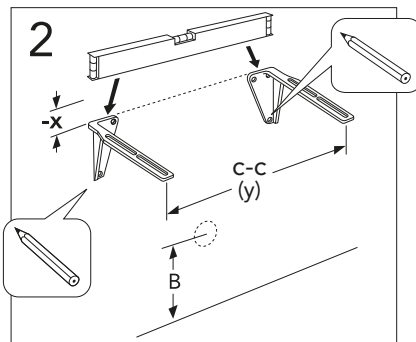
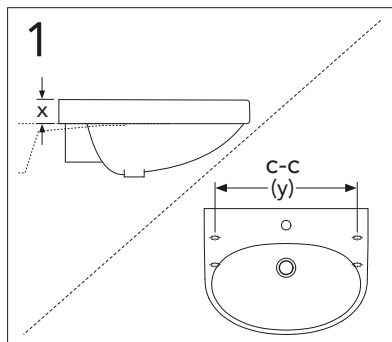

** SILICON
EN 15651-3. Class XS1
Ø5mm

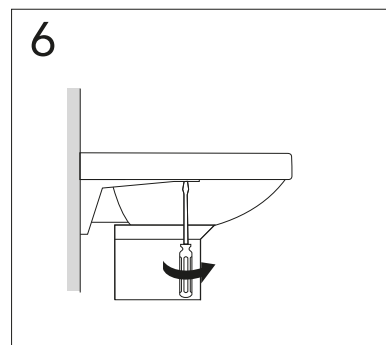
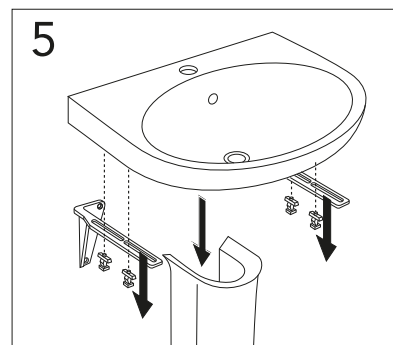
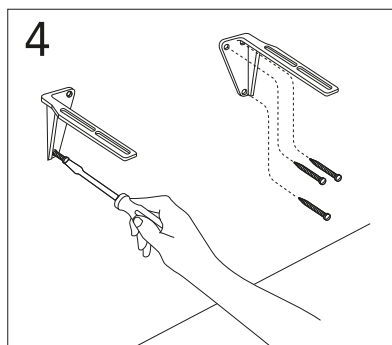
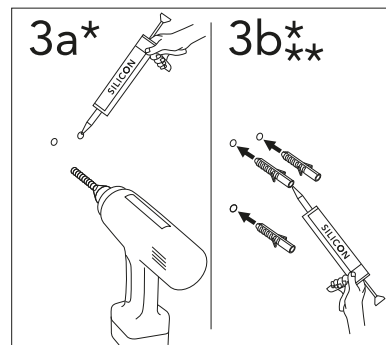
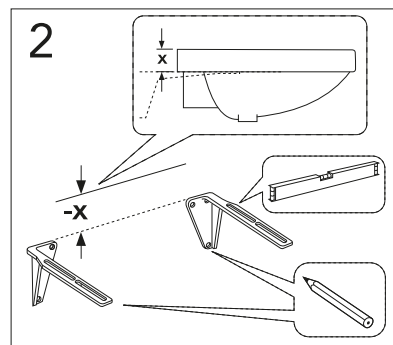
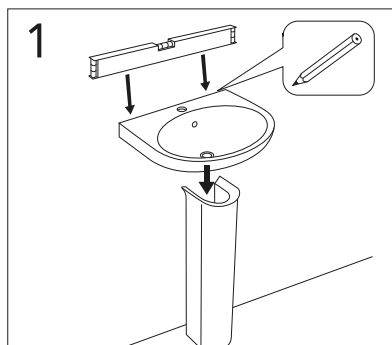

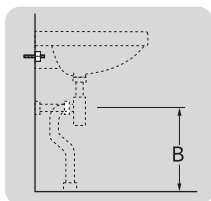

	B
SE	500 mm
FI	500 mm
NO	570mm
DK	550 mm

* SE. Enligt Branschregler, Säker vatteninstallation

Infästning och tätning ska ske enligt Branschregler Säker Vatteninstallation.

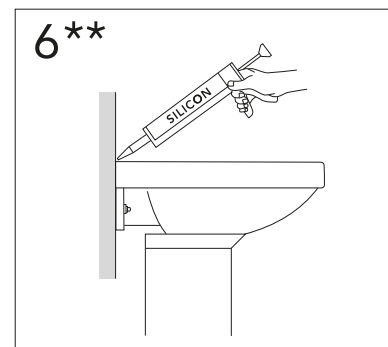
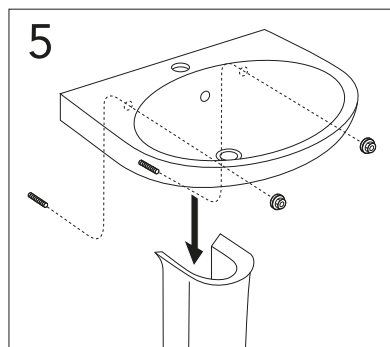
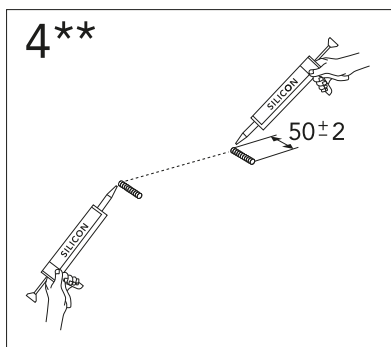
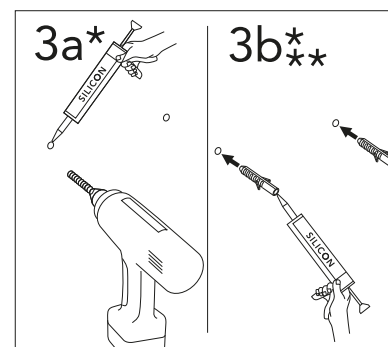
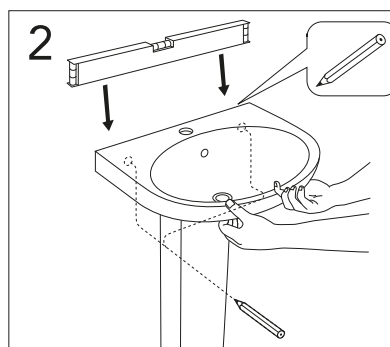
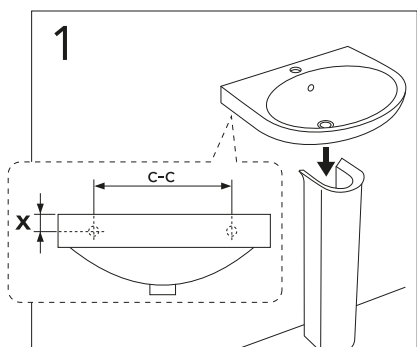
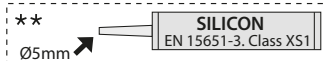
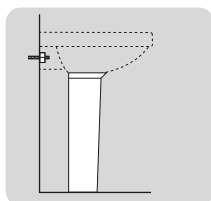
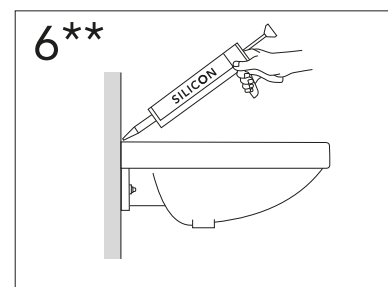
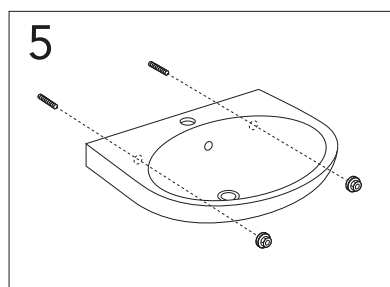
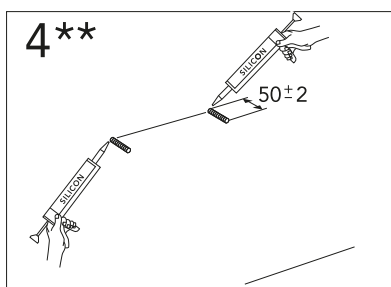
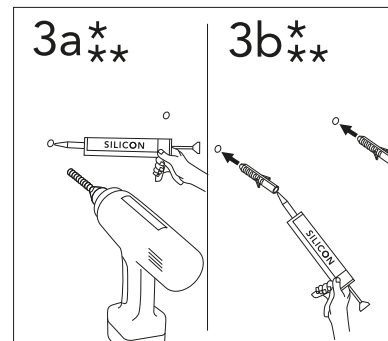
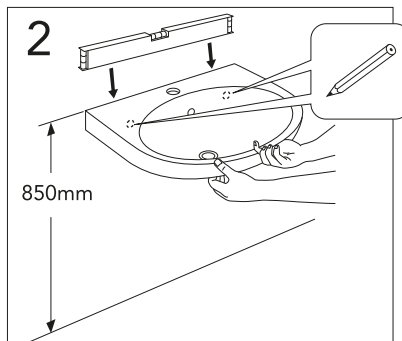
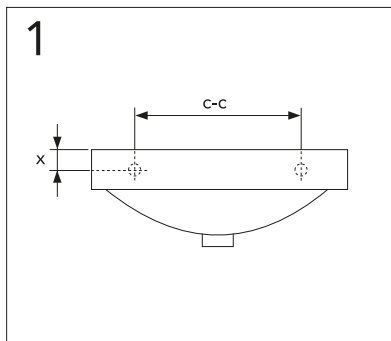
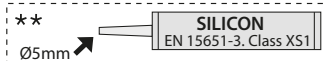
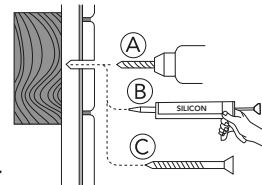

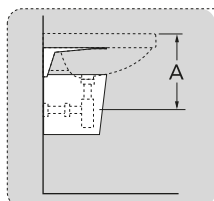

Modell	A
2930/5295	320 mm ± 15 mm
574-1	330 mm ± 25 mm
4930/4931	240 mm
5266	280 mm ± 15 mm

* SE. Enligt Branschregler, Säker vatteninstallation

Infästning och tätning ska ske enligt Branschregler Säker Vatteninstallation.

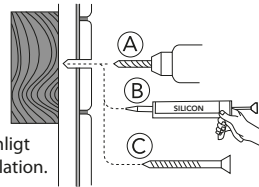

**
Ø5mm
SILICON
EN 15651-3, Class XS1

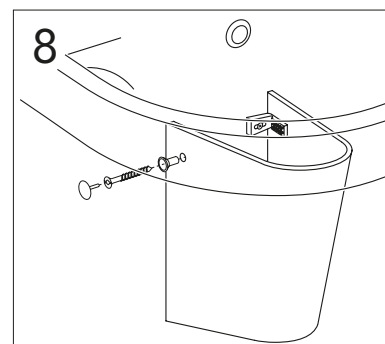
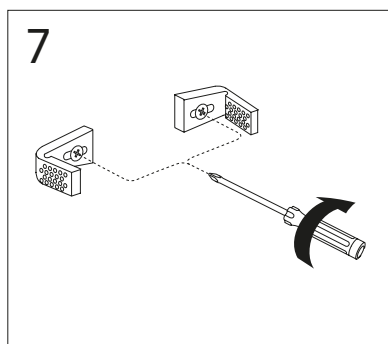
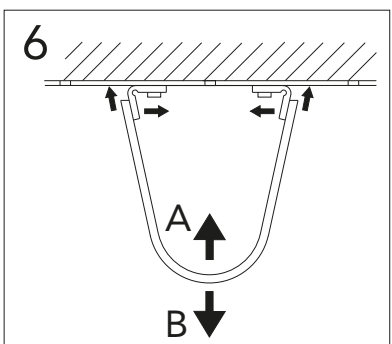
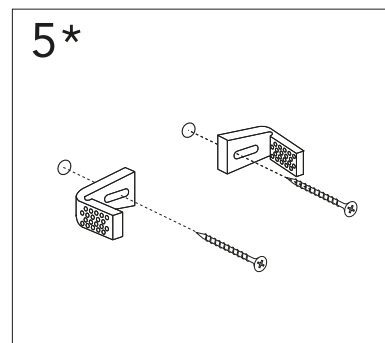
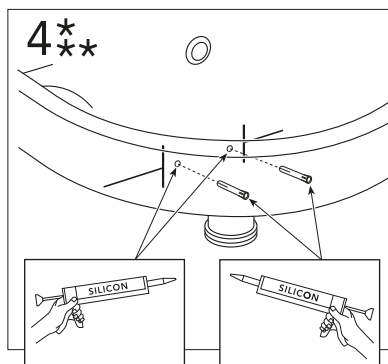
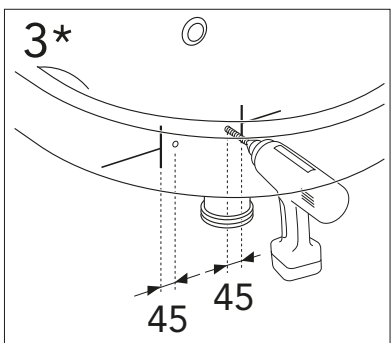
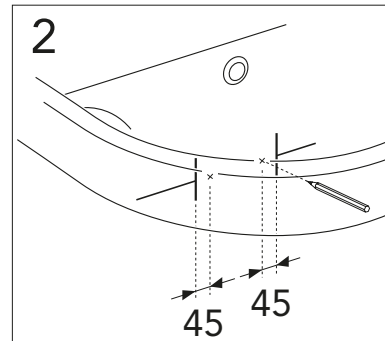
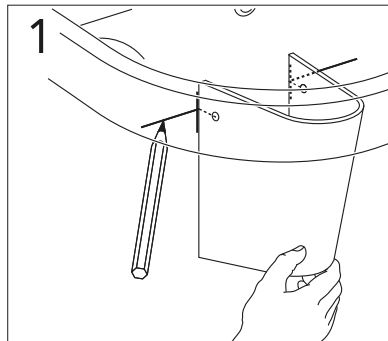
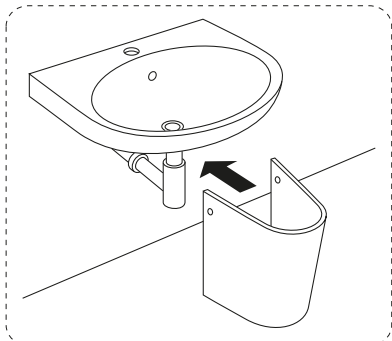



RESERVDELAR.
RESERVEDELER.
RESERVEDELE.
VARAOSAT.
SPARE PARTS.
VARUOSAD.
ATSARGINĒS DALYS.
REZERVES DAĻAS.
ЗАПАСНЫЕ ЧАСТИ.



DRIFT & SKÖTSEL
DRIFT OG VEDLIGEHODELSE
DRIFT OG VEDLIKEHOLD
ASENNUS-, KÄYTTÖ- JA HOITO-OHJEET
ASSEMBLY AND MAINTENANCE
PAIGALDAMINE & HOOLDAMINE
MONTAZA UN KOPSANA
MONTAVIMAS IR PRIEŽIURA
УСТАНОВКА И УХОД



A MEMBER OF THE
VILLEROY & BOCH GROUP

Sweden
www.gustavsberg.com/se/

Denmark
www.gustavsberg.com/dk/

Norway
www.gustavsberg.com/no/

Suomi/Finland
www.gustavsberg.com/fi/

Estonia
www.gustavsberg.com/ee/

Latvia
www.gustavsberg.com/lv/

Lithuania
www.gustavsberg.com/lt/

Україна
www.gustavsberg.com/ua/

Россия
www.gustavsberg.com/ru/