



# Oras Inspera

## INSTALLATION AND MAINTENANCE GUIDE





## Contents

<b>DK</b> Indholdsfortegnelse	<b>LT</b> Turinys	<b>PL</b> Spis treści	<b>UA</b> Зміст
<b>EE</b> Sisukord	<b>LV</b> Saturs	<b>RU</b> Содержание	
<b>FI</b> Sisällysluettelo	<b>NO</b> Innhold	<b>SE</b> Innehållsförteckning	

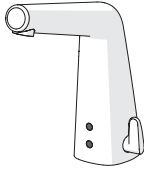

Technical data.....	4-6
Installation .....	7-9
Operation.....	10
Maintenance.....	11-18
Spare parts.....	19-20



Oras App



[apps.oras.com](https://apps.oras.com)

Apple and the Apple logo are trademarks of Apple Inc., registered in the U.S. and other countries. App Store is a service mark of Apple Inc., registered in the U.S. and other countries.

Google Play and the Google Play logo are trademarks of Google Inc.

The Bluetooth® word mark and logos are registered trademarks owned by the Bluetooth SIG, Inc. and any use of such marks by Oras Group is under license. Other trademarks and trade names are those of their respective owners.

### 3014F

EN 15091  
 I (ISO 3822)  
 100 - 1000 kPa  
 0.02 l/s (300 kPa) (with flow controller)  
 max. +70°C  
 IP 55  
 Lithium 2CR5 6V

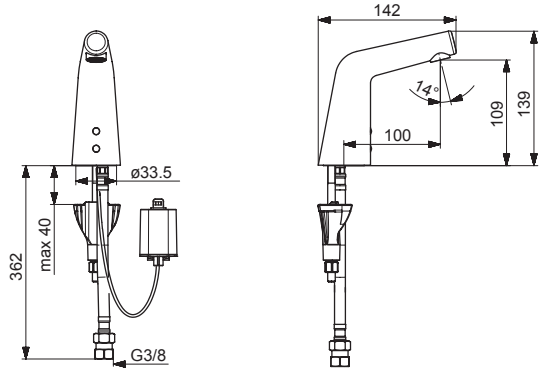

### 3016F

EN 15091  
 I (ISO 3822)  
 100 - 1000 kPa  
 0.1 l/s (300 kPa) (with flow controller)  
 200 kPa (0.1 l/s)  
 max. +70°C  
 IP 55  
 Lithium 2CR5 6V

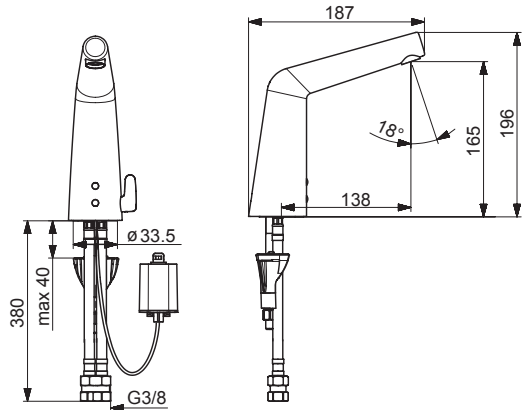

### 3017F

EN 15091  
 I (ISO 3822)  
 100 - 1000 kPa  
 0.1 l/s (300 kPa) (with flow controller)  
 200 kPa (0.1 l/s)  
 max. +70°C  
 IP 55  
 Lithium 2CR5 6V

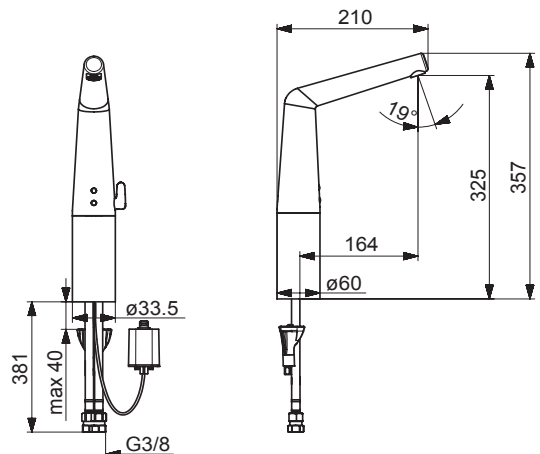

### 3014FT

EN 15091  
 I (ISO 3822)  
 100 - 1000 kPa  
 0.02 l/s (300 kPa) (with flow controller)  
 max. +70°C  
 IP 55  
 9/12 VDC

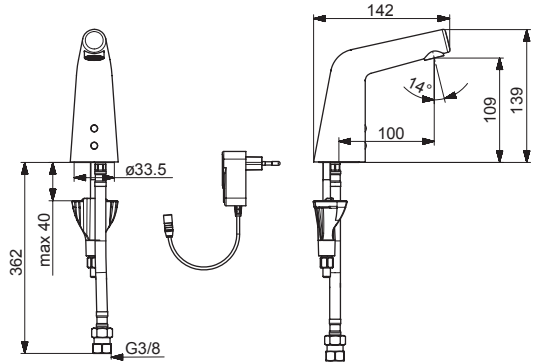

### 3016FT

EN 15091  
 I (ISO 3822)  
 100 - 1000 kPa  
 0.1 l/s (300 kPa) (with flow controller)  
 200 kPa (0.1 l/s)  
 max. +70°C  
 IP 55  
 9/12 VDC

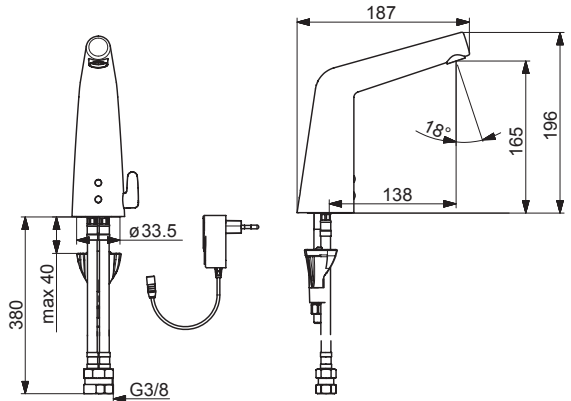

### 3017FT

EN 15091  
 I (ISO 3822)  
 100 - 1000 kPa  
 0.1 l/s (300 kPa) (with flow controller)  
 200 kPa (0.1 l/s)  
 max. +70°C  
 IP 55  
 9/12 VDC

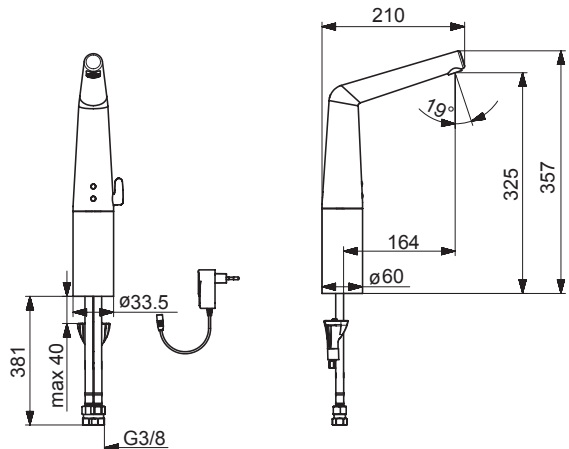

- GB** Power supply requirement: Power supply output must be short circuit protected.
- DK** Krav til strømforstyrning: Strømforsyningsudgang skal være kortslutningsbeskyttet.
- EE** Nõuded vooluallikale: Vooluallika väljund peab olema kaitstud lühise eest.
- FI** Vaatimukset virtalähteelle: Virtalähteen ulostulon tulee olla oikosulkusuojattu.
- LV** Reikalavimai maitinimo šaltiniui: turi būti apsauga nuo trumpo jungimo.
- LT** Prasības attiecībā uz barošanas ierīci: ierīces izvadām jābūt aizsargātām pret īsslēgumiem.
- NO** Krav til strømforstyrning: Strømforsyningsspennning må være kortslutningssikret.
- PL** Wymagania w stosunku do zasilacza: Zasilacz musi być wyposażony w zabezpieczenie przeciwzwarciowe.
- RU** Требования к источнику тока: Выход источника тока защищен от короткого замыкания.
- SE** Krav på matningsdon: Utspänningen skall vara kortslutningssäker.
- UA** Вимоги до джерела струму: Вихід джерела струму захищений від короткого замикання.

## Oras 199275

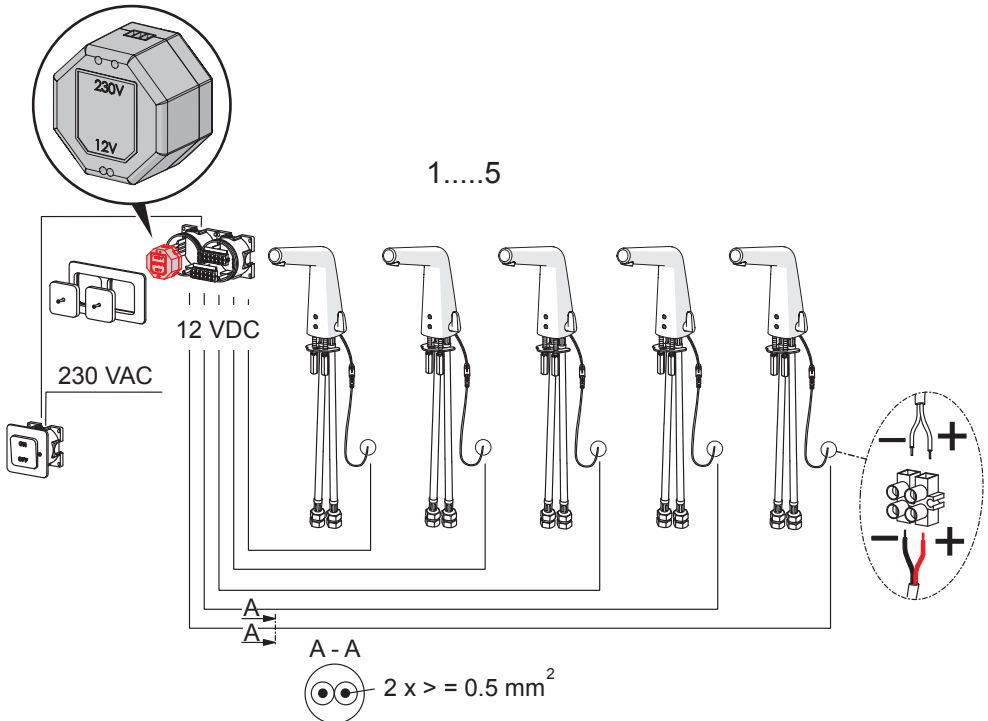

# Installation

DK Installation  
 EE Paigaldus  
 FI Asennus

LT Montavimas  
 LV Montāža  
 NO Montering

PL Instalacja  
 RU Установка  
 SE Installation

UA Встановлення

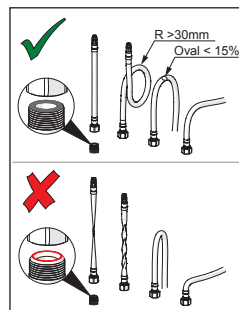
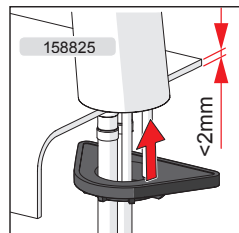
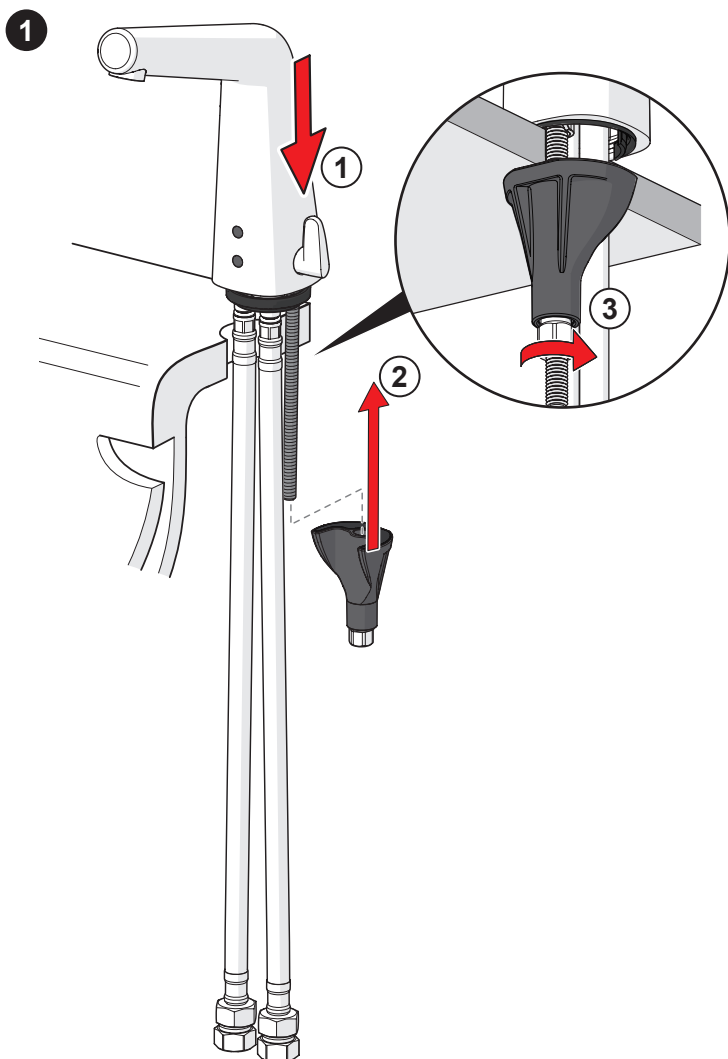
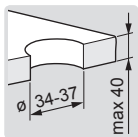
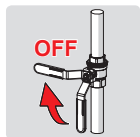

# Installation

DK Installation  
 EE Paigaldus  
 FI Asennus

LT Montavimas  
 LV Montāža  
 NO Montering

PL Instalacja  
 RU Установка  
 SE Installation

UA Встановлення



19   
 ①②③④

2

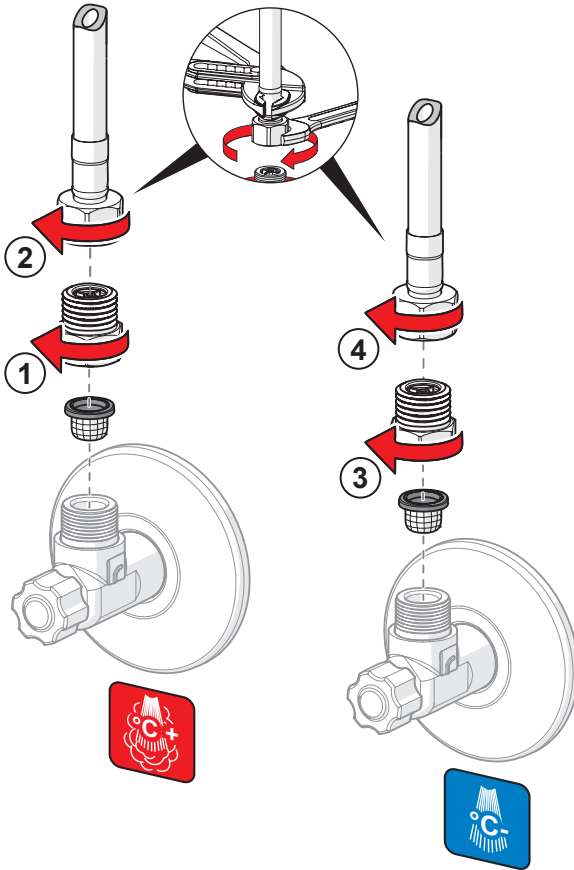



# Installation

DK Installation  
 EE Paigaldus  
 FI Asennus

LT Montavimas  
 LV Montāža  
 NO Montering

PL Instalacja  
 RU Установка  
 SE Installation

UA Встановлення

3

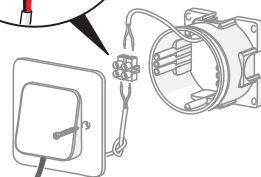
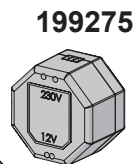
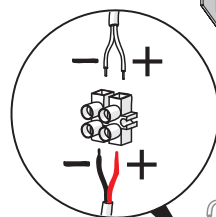
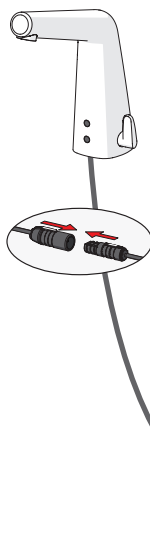
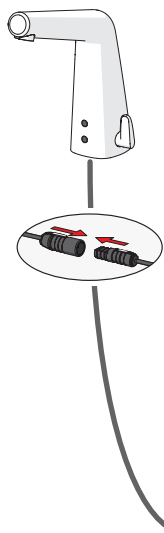
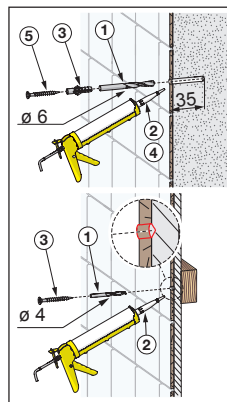
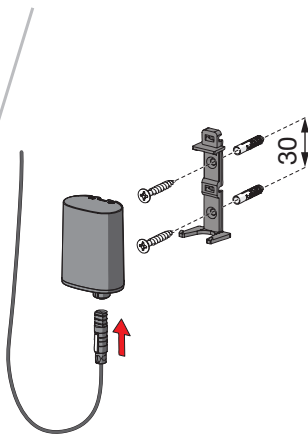
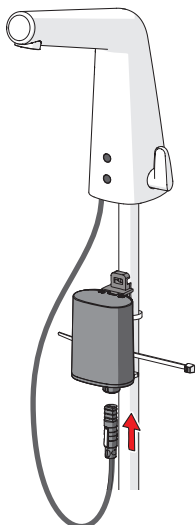

## Operation

DK Betjening  
EE Toimimine  
FI Toiminta

LT Veikimo principas  
LV Darbības princips  
NO Funksjon

PL Działanie  
RU Принцип действия  
SE Funktion

UA Принцип дії

## Automatic

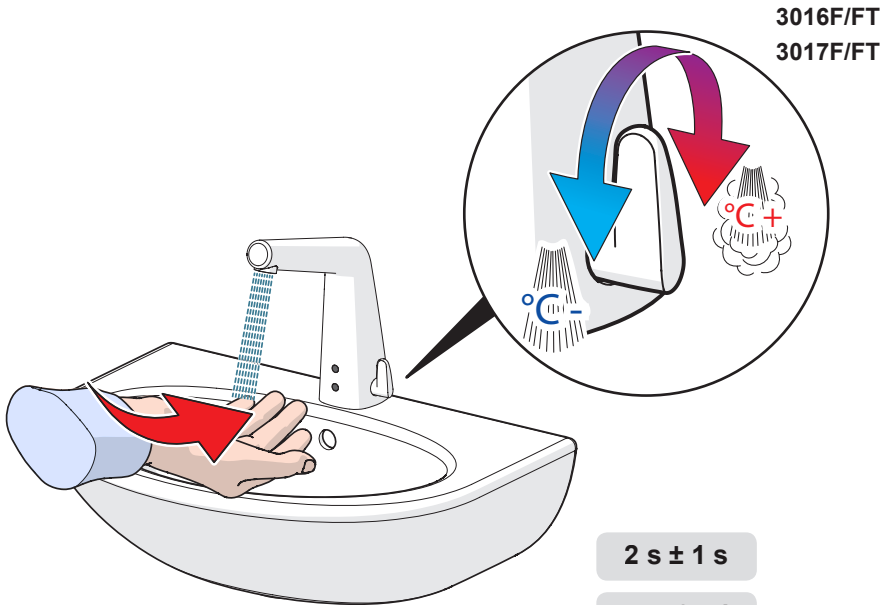
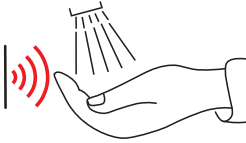

3016F/FT  
3017F/FT

2 s ± 1 s

max. 2 min

Bluetooth®

## Cleaning/changing the litter filters

**DK** Rensning/udskiftning af filtre

**EE** Prügipüüdurid puhastamine/vahetamine

**FI** Roskasiivilöiden puhdistaminen/vaihtaminen

**LT** Filtrų valymas ir pakeitimas

**LV** Dubļu filtru tīrīšana/maiņa

**NO** Rensing/bytting av filter

**PL** Czyszczenie/wymiana filtra

**RU** Очистка и замена уплотнительных фильтро

**SE** Rengöring/byte av smutsfilter

**UA** Чищення та заміна ущільнюючих фільтрів

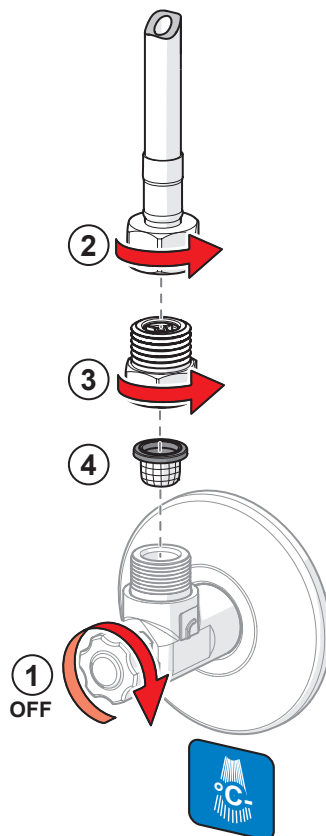
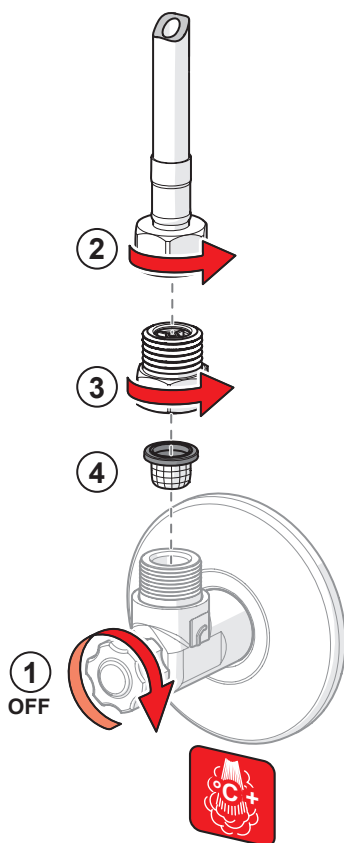
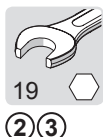

## Changing the battery

DK Udsiftning af batteri

EE Patarei vahetamine

FI Pariston vaihto

LT Baterijos pakeitimas

LV Baterijas maiņa

NO Bytting av batteri

PL Wymiana baterii zasilajacej

RU Замена батареек

SE Byte av batteri

UA Заміна батарейки



①

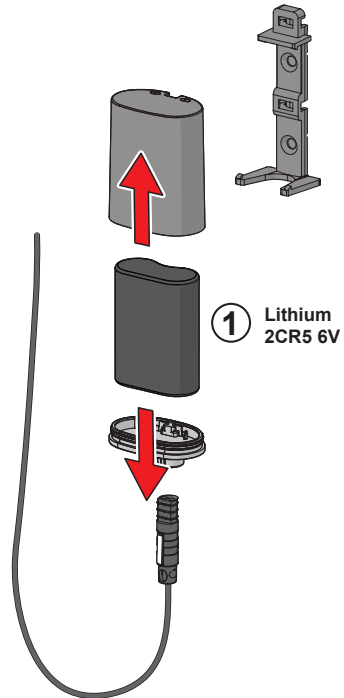

## Servicing the solenoid valve

**CZ** Servis solenoidového ventilu

**DE** Wartung der Magnetventil

**DK** Rensning/udskiftning af magnetventilens

**EE** Magnetventiili vahetamine

**ES** Cambiar la válvula magnética

**FI** Magneettiventtiilin vaihto

**FR** Changement de l'électrovanne

**IT** Sostituzione della valvola magnetica

**LT** Elektromagnetinio vožtuvo pakeitimas

**LV** Elektromagnētiskā vārsta maiņa

**NL** Vervanging van de magneetventiel

**NO** Bytting av magnetventil

**PL** Wymiana zaworu solenoidowego

**RO** Întreținerea valvei solenoidale

**RU** Замена электромагнитного клапана

**SE** Byte av magnetventil

**SK** Výmena elektromagnetického ventilu

**UA** Заміна електро магнітного клапана

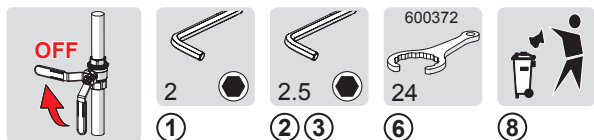

**3016F/FT**  
**3017F/FT**

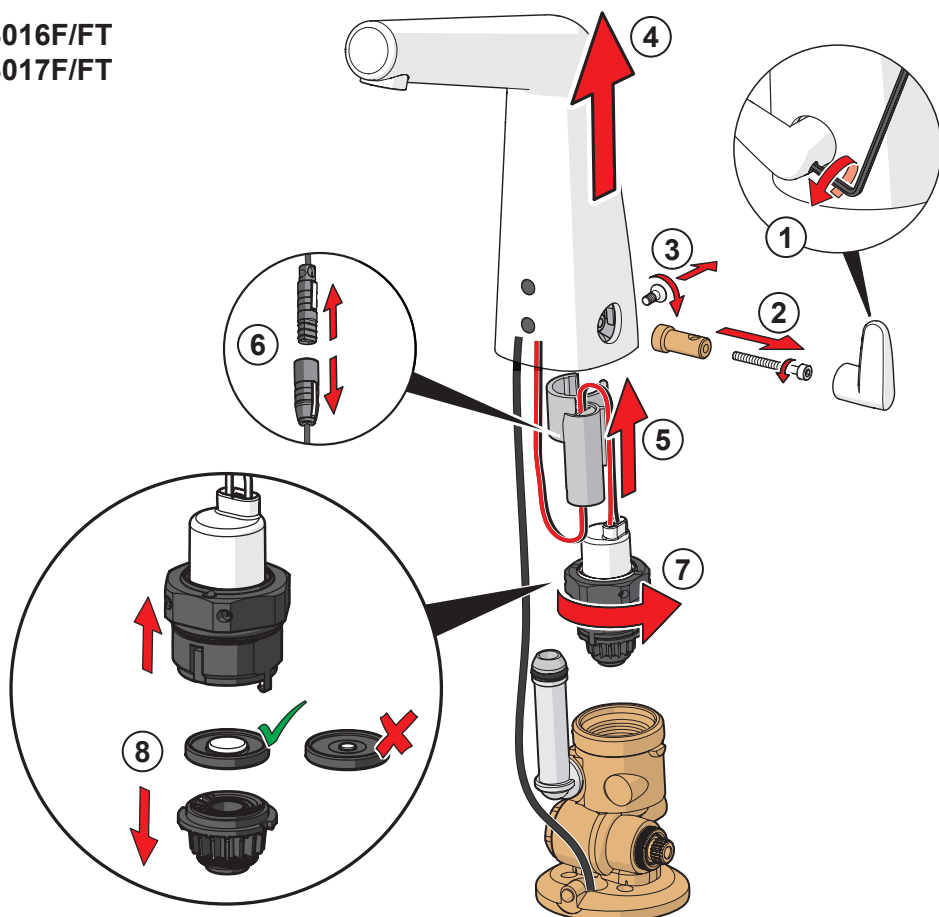

## Changing the sensor

DK Udsiftning af sensoren  
 EE Sensori vahetamine  
 FI Sensorin vaihto  
 LT Jutiklio pakeitimas

LV Sensora maiņa  
 NO Bytting av sensor  
 PL Wymiana sensora  
 RU Замена датчика, модели

SE Byte av sensor  
 UA Заміна датчика

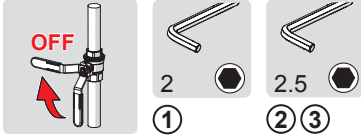

3016F/FT  
 3017F/FT

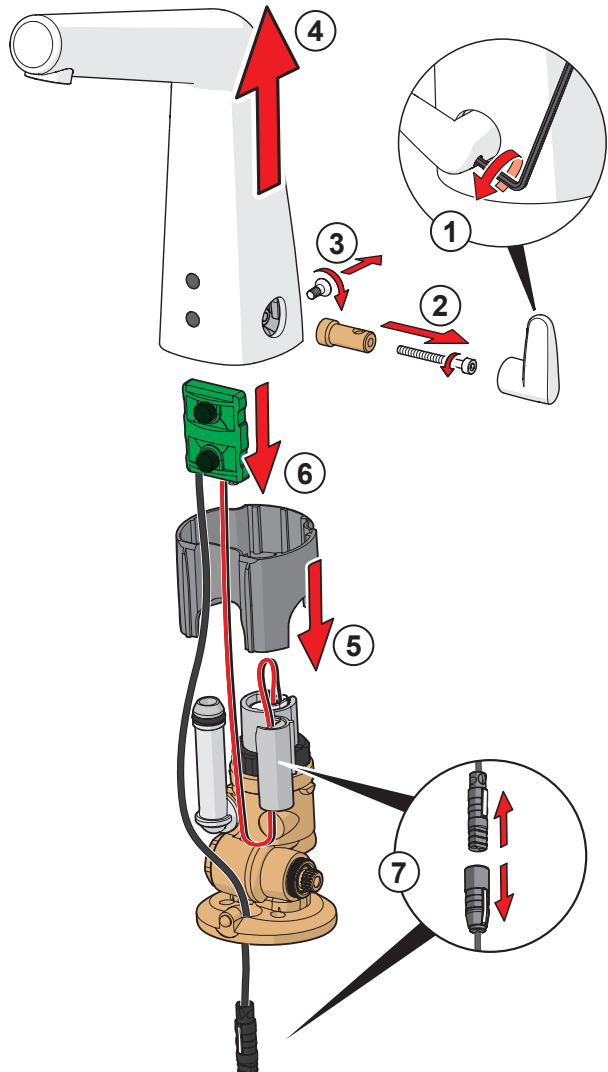

## Changing the temperature regulator

**DK** Udskiftning af temperatur reguleringsdel  
**EE** Temperatuuriseadja vahetamine  
**FI** Lämmönsäätimen vaihto  
**LT** Temperatūros regulatoriaus keitimas  
**LV** Temperatūras regulatora maiņa

**NO** Bytting av temperaturreguleringsdel  
**PL** Wymiana regulatora temperatury  
**RU** Замена регулятора температуры  
**SE** Byte av blandningsventil  
**UA** Заміна регулятора температури

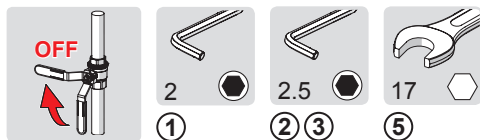

**3016F/FT**  
**3017F/FT**

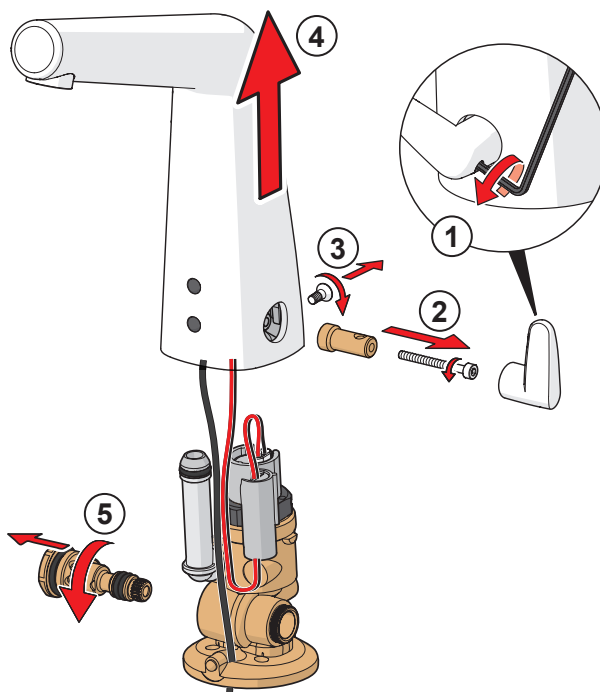

## Servicing the solenoid valve

**CZ** Servis solenoidového ventilu  
**DE** Wartung der Magnetventil  
**DK** Rensning/udskiftning af magnetventilens  
**EE** Magnetventiili vahetamine  
**ES** Cambiar la válvula magnética  
**FI** Magneettiventtiilin vaihto  
**FR** Changement de l'électrovanne  
**IT** Sostituzione della valvola magnetica  
**LT** Elektromagnetinio vožtuvo pakeitimas

**LV** Elektromagnētiskā vārsta maiņa  
**NL** Vervanging van de magneetventiel  
**NO** Bytting av magnetventil  
**PL** Wymiana zaworu solenoidowego  
**RO** Întreținerea valvei solenoidale  
**RU** Замена злектромагнитного клапана  
**SE** Byte av magnetventil  
**SK** Výmena elektromagnetického ventilu  
**UA** Заміна електроманітного клапана

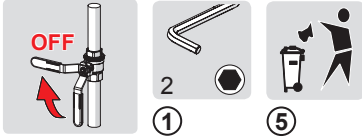

3014F/FT

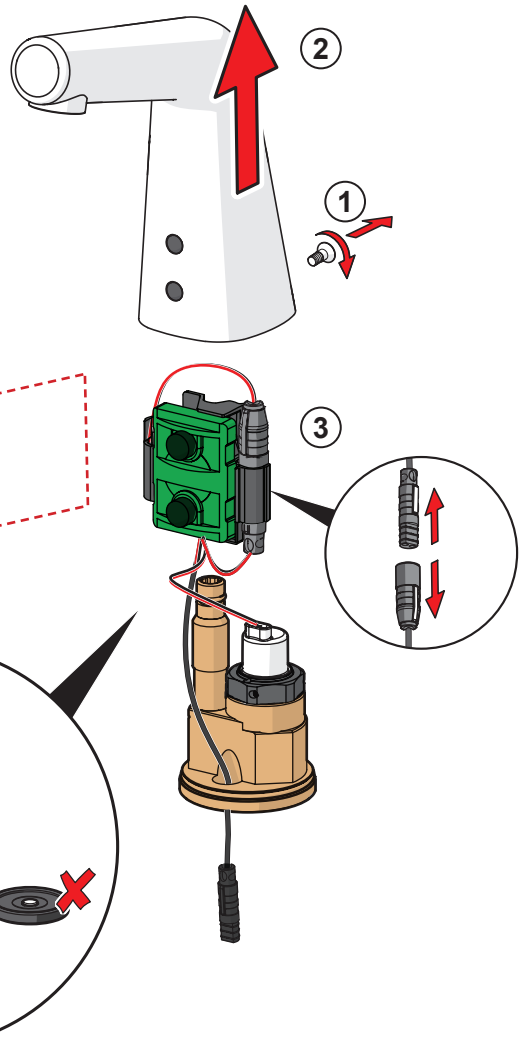



## Changing the sensor

**DK** Udskiftning af sensoren

**EE** Sensori vahetamine

**FI** Sensorin vaihto

**LT** Jutiklio pakeitimas

**LV** Sensora maiņa

**NO** Bytting av sensor

**PL** Wymiana sensora

**RU** Замена датчика, модели

**SE** Byte av sensor

**UA** Заміна датчика

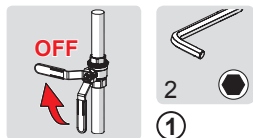

**3014F/FT**

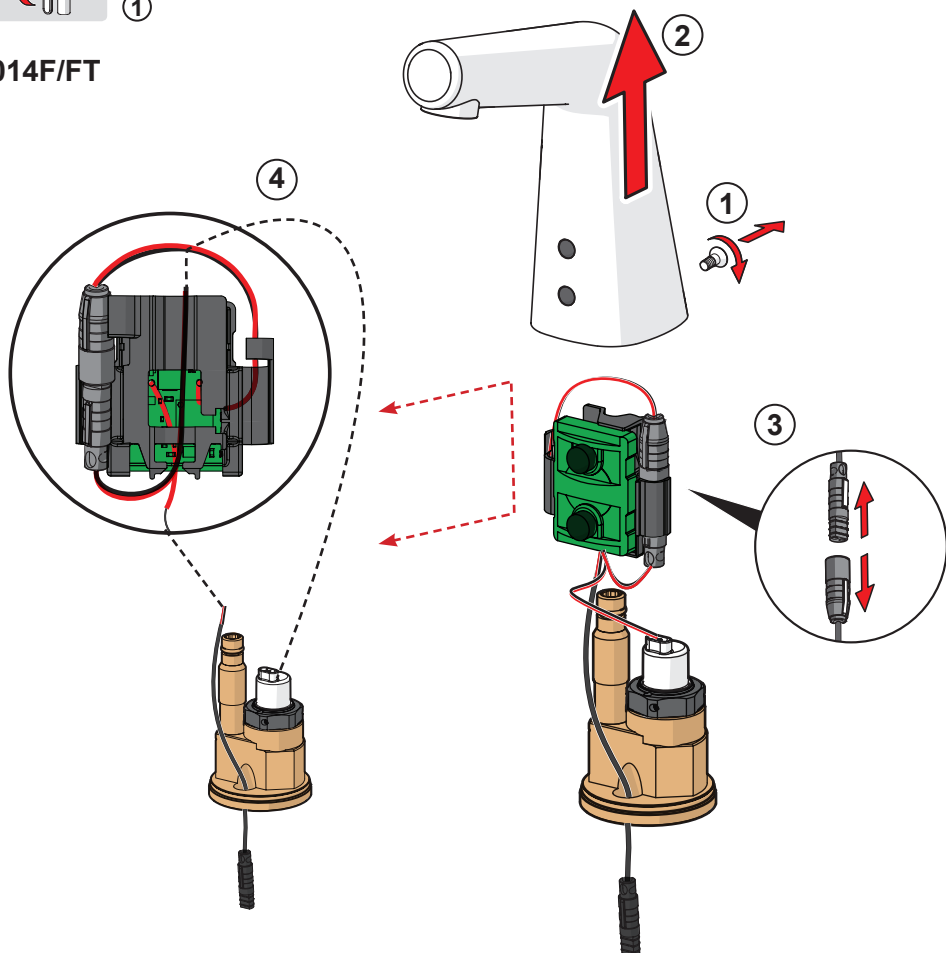

## Cleaning the faucet

DK Rengøring af armaturet  
 EE Puhastamine  
 FI Puhdistus  
 LT Maišytuvo valymas

LV Krāna tīrīšana  
 NO Rengjøring av kranen  
 PL Czyszczenie baterii  
 RU Чистка смесителя

SE Rengöring av blandarna  
 UA Чищення змішувача

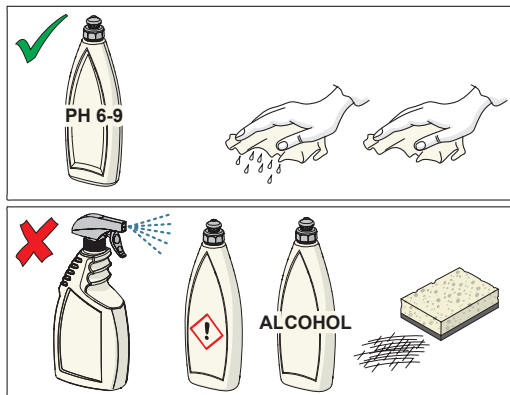
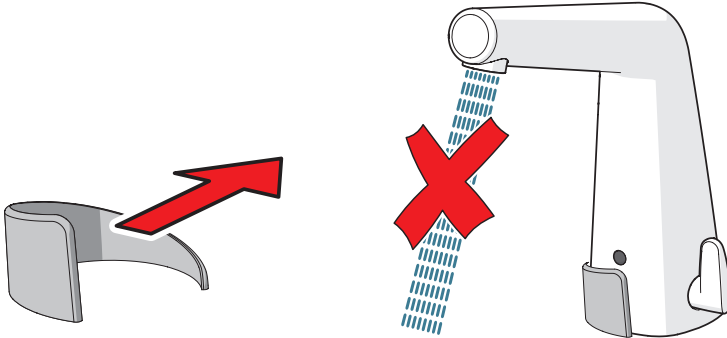
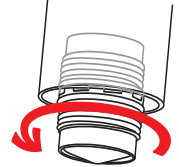
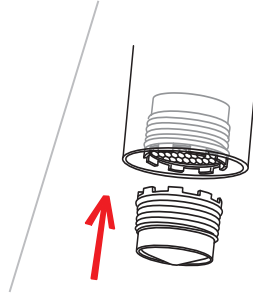
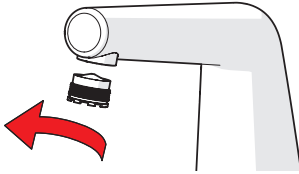
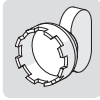

## Spare parts

**DK** Reservedele  
**EE** Varuosad  
**FI** Varaosat

**LT** Atsarginės dalys  
**LV** Rezerves daļas  
**NO** Reservedeler

**PL** Części zamienne  
**RU** Запасные части  
**SE** Reservdelar

**UA** Запасні частини

### 3014F, 3014FT

- 1 1002024V
- 2 1001424V
- 3 199205V
- 4 199206V
- 5 198473/2
- 6 199257/2
- 7 600705/10
- 8 1000780V
- 9 602610V
- 10 1002371V
- 11 601481/2
- 12 199438V (3014F)
- 13 198330 (3014F)

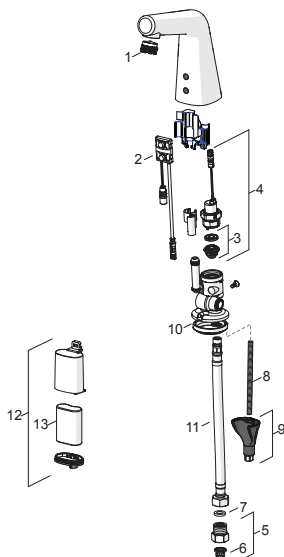

### 3016F, 3016FT

- 1 1002424V
- 2 199205V
- 3 199206V
- 4 1001424V
- 5 601901V
- 6 198473/2
- 7 199257/2
- 8 600705/10
- 9 199201V
- 10 1000780V
- 11 602610V
- 12 1002371V
- 13 1002311/2
- 14 199438V (3016F)
- 15 198330 (3016F)

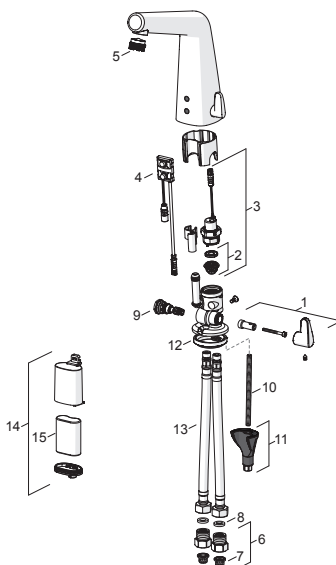

## Spare parts

**DK** Reservedele  
**EE** Varuosad  
**FI** Varaosat

**LT** Atsarginės dalys  
**LV** Rezerves daļas  
**NO** Reservedeler

**PL** Części zamienne  
**RU** Запасные части  
**SE** Reservdelar

**UA** Запасні частини

### 3017F, 3017FT

- 1 1002424V
- 2 199205V
- 3 199206V
- 4 1001424V
- 5 601901V
- 6 198473/2
- 7 199257/2
- 8 600705/10
- 9 199201V
- 10 1000780V
- 11 602610V
- 12 1002371V
- 13 602328/2
- 14 199438V (3017F)
- 15 198330 (3017F)

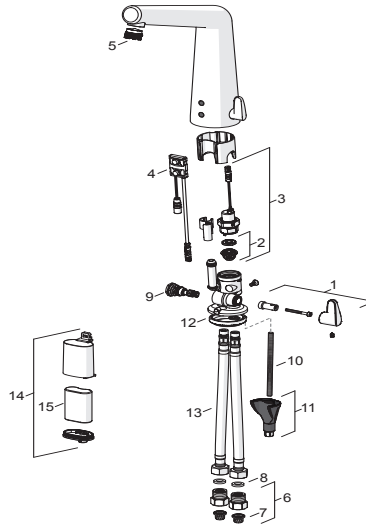







Oras Group is a powerful European provider of sanitary fittings: the market leader in the Nordics and a leading company in Continental Europe. The company's mission is to make the use of water easy and sustainable and its vision is to become the European leader of advanced sanitary fittings. Oras Group has two strong brands, Oras and Hansa.

The head office of the Group is located in Rauma, Finland, and the Group has four manufacturing sites: Burglengenfeld (Germany), Kralovice (Czech Republic), Olesno (Poland) and Rauma (Finland). Oras Group employs approximately 1400 people in twenty countries. Oras Group is owned by Oras Invest, a family company and an industrial owner.

ORAS GROUP

Isometsäntie 2, P.O. Box 40

FI-26101 Rauma

Tel. +358 2 83 161

Fax +358 2 831 6300

[info.finland@oras.com](mailto:info.finland@oras.com)

[www.oras.com](http://www.oras.com)

