

| | | |
|-----------|------------------------------|-----------|
| DE | Montageanleitung | 2 |
| FR | Instructions de montage | 2 |
| EN | assembly instructions | 3 |
| IT | Istruzioni per Installazione | 3 |
| ES | Instrucciones de montaje | 4 |
| NL | Handleiding | 4 |
| DK | Monteringsvejledning | 5 |
| PT | Manual de Instalação | 5 |
| PL | Instrukcja montażu | 6 |
| CS | Montážní návod | 6 |
| SK | Montážny návod | 7 |
| ZH | 组装说明 | 7 |
| RU | Инструкция по монтажу | 8 |
| HU | Szerelési útmutató | 8 |
| FI | Asennusohje | 9 |
| SV | Monteringsanvisning | 9 |
| LT | Montavimo instrukcijos | 10 |
| HR | Uputstva za instalaciju | 10 |
| TR | Montaj kılavuzu | 11 |
| RO | Instrucțiuni de montare | 11 |
| EL | Οδηγία συναρμολόγησης | 12 |
| SL | Navodila za montažo | 12 |
| ET | Paigaldusjuhend | 13 |
| LV | Montāžas instrukcija | 13 |
| SR | Uputstvo za montažu | 14 |
| NO | Montasjeveiledning | 14 |
| BG | Ръководство за монтаж | 15 |
| SQ | Udhëzime rreth montimit | 15 |
| AR | تعليمات التجميع | 16 |

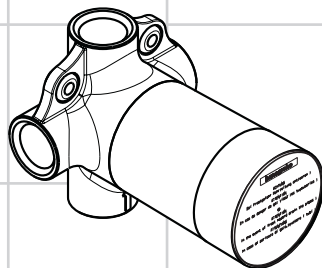

Quattro

15930180 / 15930187



Sigurnosne napomene

- ⚠ Prilikom montaže se radi sprečavanja prignječenja i posekotina moraju nositi rukavice.
- ⚠ Velika razlika u pritisku između vruće i hladne vode mora biti izbalansirana.

Instrukcije za montažu

- Pre montaže se mora proveriti da li je proizvod oštećen pri transportu. Nakon ugradnje se ne priznaju nikakve reklamacije koje se odnose na površinska i transportna oštećenja.
- Vodovi i armatura moraju biti postavljeni, isprani i testirani prema važećim normama.
- Treba se pridržavati propisa koji u određenim zemljama važe za instalacije.
- Armatura se mora montirati tako da bude izolovana i zvučno odvojena.

Opis simbola



Nemojte koristiti silikon koji sadrži sirćetnu kiselinu!



Mere (vidi stranu 17)



Rezervni delovi (vidi stranu 21)



Poseban pribor (Nije sadržano u isporuci)

Produžetak #92990000 (vidi stranu 21)



Završni set (vidi stranu 22)



Primeri montaže (vidi stranu 18)

A Quattro četvorostruki preusmerivač

B Uzidni ventil

C Termostat

D Termostat s ventilom za zatvaranje

Sikkerhetshenvisninger

- ⚠ Bruk hansker under montasjen for å unngå klem- og kuttskader.
- ⚠ Store trykkdifferanser mellom kaldt- og varmtvannstilkoblinger skal utlignes.

Montagehenvisninger

- Før montasjen skal produktet sjekkes for transportskader. Etter monteringen aksepteres ikke noen transport- eller overflateskader.
- Ledningene og armaturen skal monteres, spyles og sjekkes iht. de gyldige normer.
- Gjeldende retningslinjer for rørleggerarbeid i de enkelte land skal følges.
- Armaturen skal monteres isolert og støyfrikoblet.

Symbolbeskrivelse



Ikke bruk silikon som inneholder eddiksyre!



Mål (se side 17)



Servicedeler (se side 21)



Ekstratilbehør (ikke med i leveransen)

Forlengelse #92990000 (se side 21)



Ferdigsett (se side 22)



Montasje-eksempel (se side 18)

A Quattro fire-veis omstilling

B Innfelt ventil

C Termostat

D Termostat med sperreventil



Ispitni znak (vidi stranu 17)



Prøvermerke (se side 17)

Montaža
vidi stranu 20



Montasje
se side 20

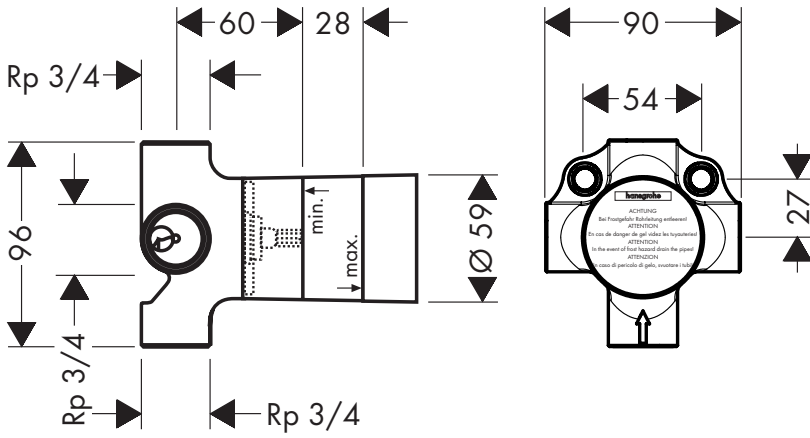
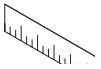

| | P-IX | DVGW | SVGW | WRAS | KIWA | NF | ACS | ETA |
|----------|------|------|------|------|------|----|-----|-----|
| 15930180 | | | X | X | | | X | |
| 15930187 | | | | | | | | |

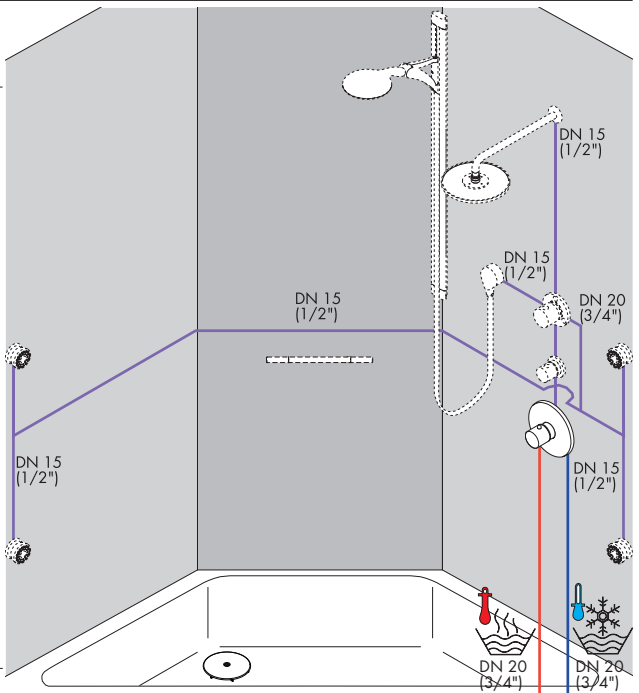
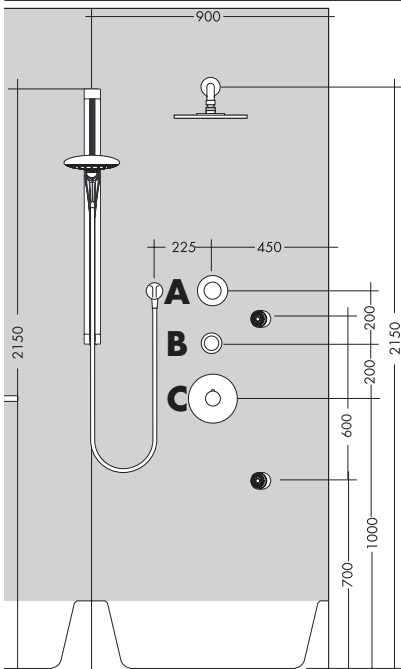
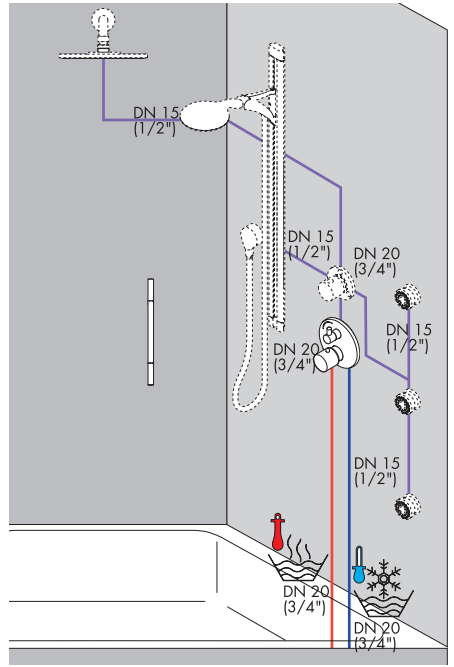
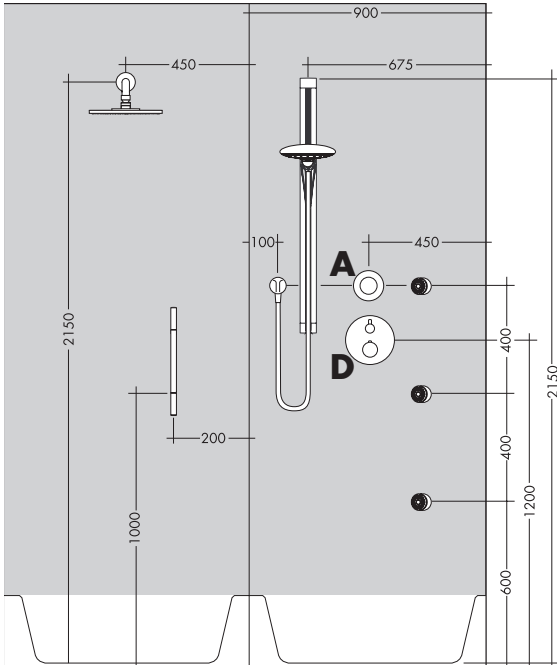

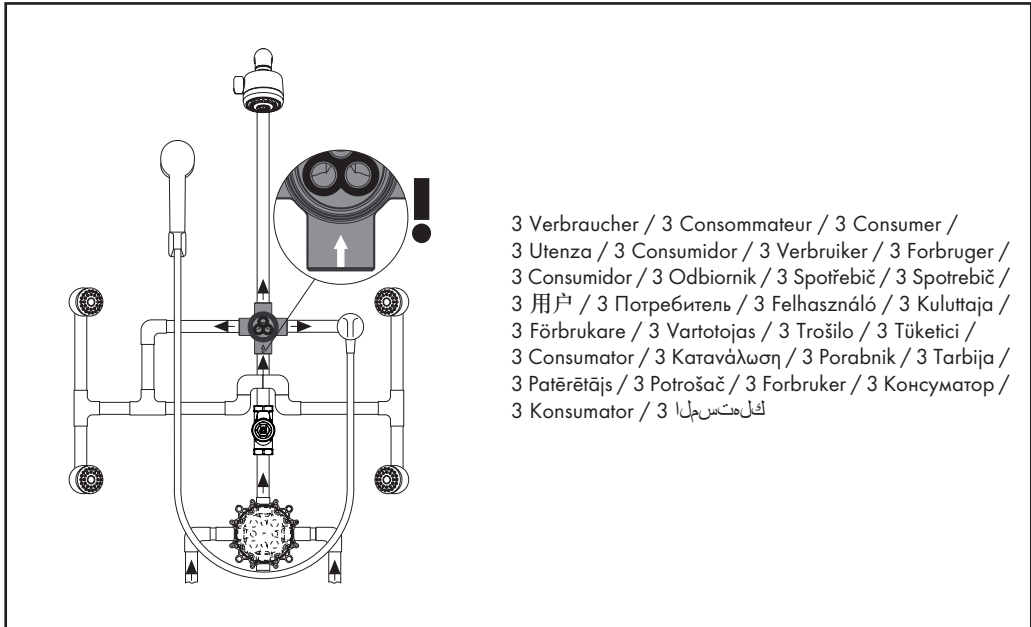

3 Verbraucher / 3 Consommateur / 3 Consumer /
 3 Utenza / 3 Consumidor / 3 Verbruiker / 3 Forbruger /
 3 Consumidor / 3 Odbiornik / 3 Spotřebič / 3 Spotřebič /
 3 用户 / 3 Потребитель / 3 Felhasználó / 3 Kuluttaja /
 3 Förbrukare / 3 Vartotojas / 3 Trošilo / 3 Tüketic /
 3 Consumator / 3 Κατανάλωση / 3 Porabnik / 3 Tarbija /
 3 Patērētājs / 3 Potrošač / 3 Forbruker / 3 Консуматор /
 3 Konsumator / 3 كل متسجلا

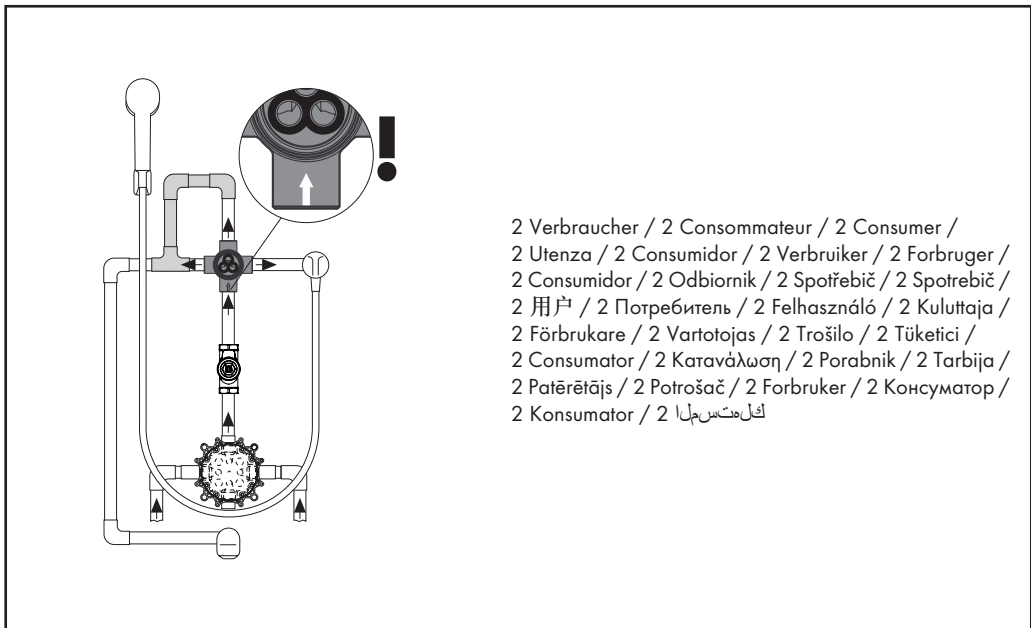

2 Verbraucher / 2 Consommateur / 2 Consumer /
 2 Utenza / 2 Consumidor / 2 Verbruiker / 2 Forbruger /
 2 Consumidor / 2 Odbiornik / 2 Spotřebič / 2 Spotřebič /
 2 用户 / 2 Потребитель / 2 Felhasználó / 2 Kuluttaja /
 2 Förbrukare / 2 Vartotojas / 2 Trošilo / 2 Tüketic /
 2 Consumator / 2 Κατανάλωση / 2 Porabnik / 2 Tarbija /
 2 Patērētājs / 2 Potrošač / 2 Forbruker / 2 Консуматор /
 2 Konsumator / 2 كل متسجلا



Schallentkopplung / silencieux / noise reduction / sorbente acusticor / Silenciador / ruisdemper / Lyuddkoblingen /
Isolamento acústico / Odsprężenie akustyczne / Zvukové odstínění / Zvukové odčinenie / 隔音装置 /
Шумоизоляция / Zajmtenesító / Äänieriste / Isolering / Garso slopinimas / Zvučna izolacija / Ses ayırma /
Izolare fonică / Ηχομόνωση / Ločitev zvoka / Müraisolatsioon / Skaņu slāpējošs pieslēgums / Zvučna izolacija /
Støavkobling / Заглушител / Ndarësi i ekos / تحويل صدى الصوت

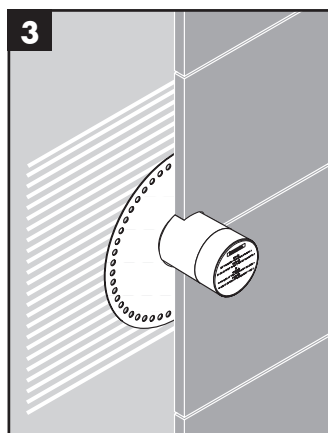
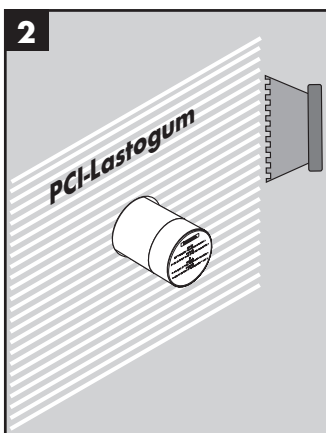
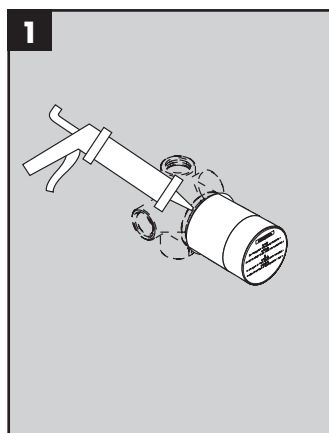
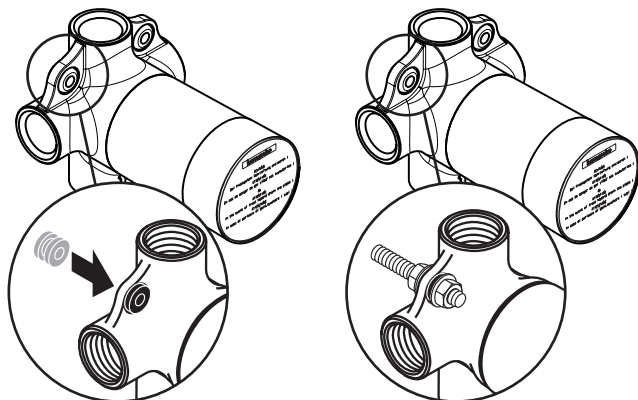

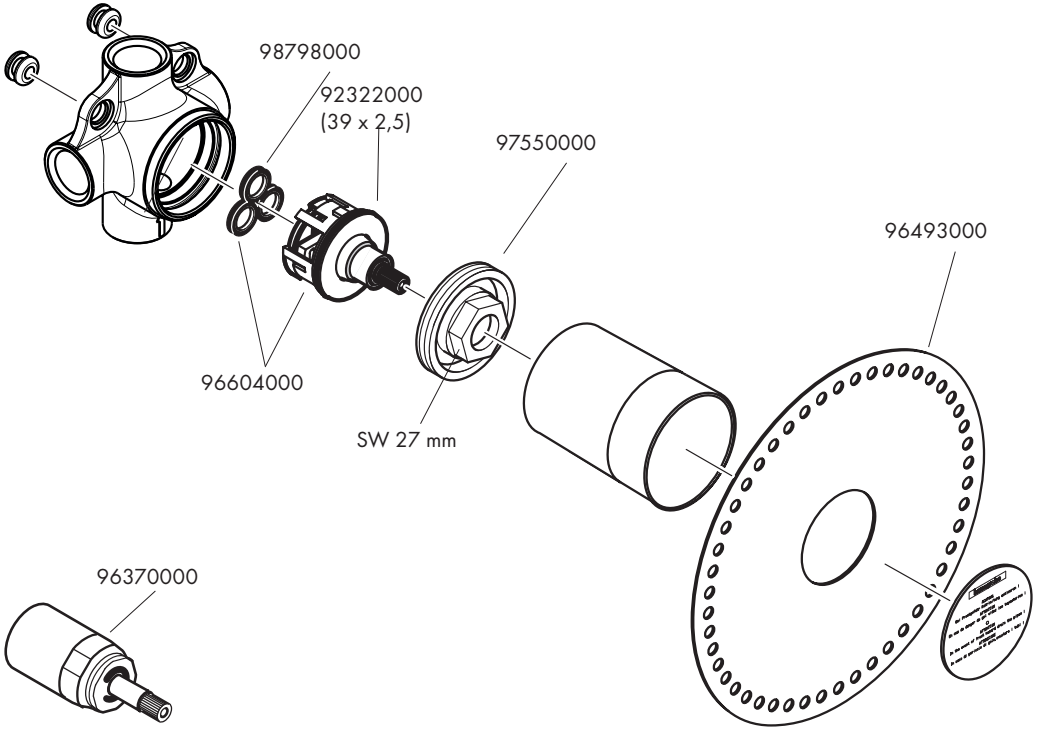



Trio / Quattro E 15931XXX

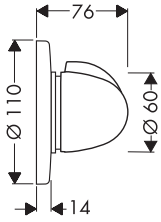

Trio / Quattro S 15932XXX

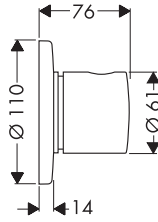

Trio / Quattro Metris 31634XXX

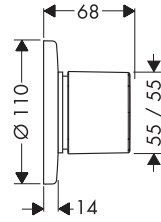

Trio / Quattro PuraVida 15937XXX

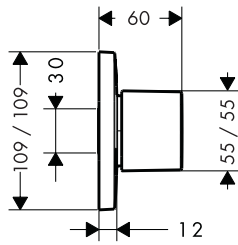

Trio / Quattro Classic 15934XXX

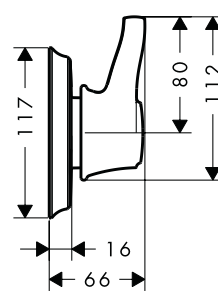

hansgrohe

Hansgrohe · AuestraÙe 5 · 9 · D-77761 Schiltach · Telefon +49 (0) 78 36/51-1282 · Telefax +49 (0) 7836/511440
E-Mail: info@hansgrohe.com · Internet: www.hansgrohe.com

08/2018
9,09143.03