

- SE MONTERINGSANVISNING NAUTIC WC OCH BIDÉ
- DK MONTERINGSVEJLEDNING NAUTIC WC OG BIDET
- NO MONTERINGSANVISNING NAUTIC WC OG BIDÉ
- FI ASENNUSOHJE, NAUTIC WC JA PESUISTUIN
- GB INSTALLATION INSTRUCTIONS NAUTIC WC AND BIDET
- EE PAIGALDUSJUHENDID NAUTIC WC-DELE JA BIDEEDELE
- LV UZSTĀDĪŠANAS INSTRUKCIJA NAUTIC WC UN BIDĒ
- LT NAUTIC UNITAZO IR BIDĖ MONTAVIMO INSTRUKCIJA
- RU Инструкция по установке унитазов и биде NAUTIC
- CZ NÁVOD PRO INSTALACI WC A BIDETU NAUTIC
- SK NÁVOD NA INŠTALÁCIU WC A BIDETU NAUTIC

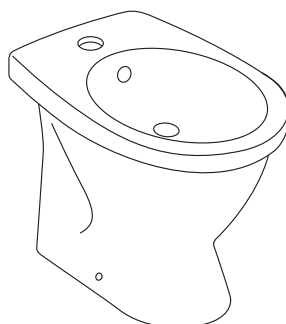
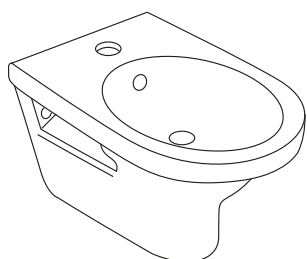
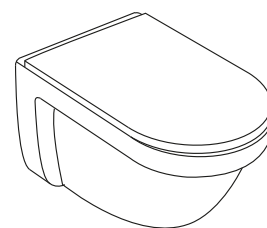
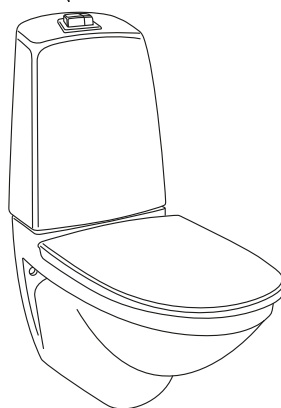
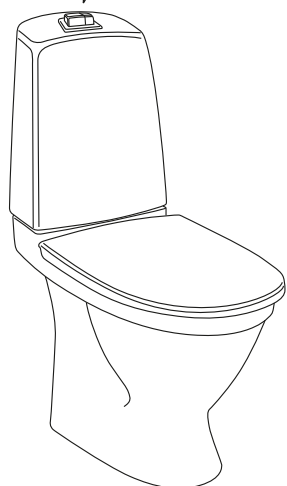
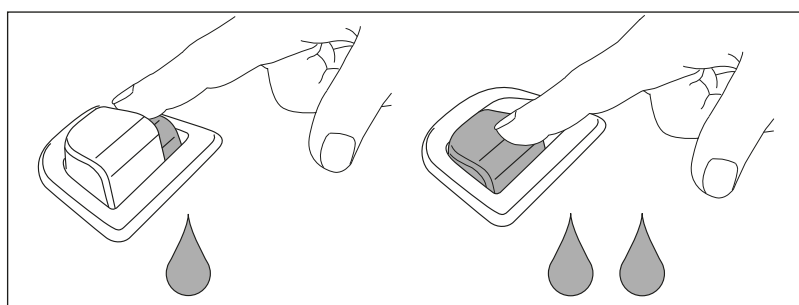

	Garanti. Takuu. Guarantee. Garantii. Garantija. Garantija. Гарантія. Záruka.	3/22
	Nautic 1500 Nautic 1591 Nautic 5510 Nautic 1510 Nautic 1596 Nautic 5591 Nautic 1522 Nautic 5500 Nautic 1546 Nautic 5546	4 - 5/22
	Nautic 1500 Nautic 1596 Nautic 5591 Nautic 1510 Nautic 5500 Nautic 1546 Nautic 5510 Nautic 1591 Nautic 5546	6/22
		7/22
	Nautic 5530	8/22
	Nautic 1522. 5522	9/22
	Nautic 5599	10/22
	Nautic 5598	11/22
	Service. Tjeneste. Huolto. Hooldus. Techninė pagalba. Pakalpojums. Обслуживание. Oprava.	12-18/22
	9M26S101/9M26S136	19/22
	9M256101	20/22
	Reservdelar. Reservedeler. Reservedele. Varaosat. Spare parts. Varuosad. Atsarginės dalys. Rezerves daļas. Запасные части. Náhradní díly. Náhradné diely.	21/22
	Skötsel av porslinsprodukter Rengøring og pleje af sanitetsprodukter Vedlikehold av sanitærporselen Käyttö- ja hoito-ohje, posliinutuotteet Maintenance of ceramic products Keraamikatoodete hooldamine Kopšanas instrukcija keramikas produktiem Keramikos gaminių priežiūra Уход за керамическими изделиями Údržba výrobků z keramiky Údržba výrobkov z keramiky	24/22

SE GARANTI

Produkten har garanti enligt respektive lands gällande branschvillkor.

Direktiv vid reklamation.

Våra produkter är tillverkade enligt väldigt stränga kvalitetskrav. Om en produkt trots det är felaktig, ber vi er i första hand att kontakta din återförsäljare. Ärendet underlättas genom att uppvisa kvitto och uppge produktnummer och inköpsdatum.

DK GARANTI

Produktet har garanti i forhold til gældende dansk lovgivning.

Vejledning ved reklamation.

Vores produkter er fremstillet i overensstemmelse med markedets strengeste krav til kvalitet. Skulle produktet mod forventning være behæftet med fejl henviser vi til den forhandler, hvor produktet er købt. Kvittering skal kunne fremvises, hvis forhandleren forlanger det, ligesom oplysninger om produktnummer og købsdato skal kunne dokumenteres.

NO GARANTI

Produktene har garanti i henhold til respektive lands gjeldende bransjevilkår.

Instruksjer ved reklamasjon.

Våre produkter er produsert i henhold til veldig strenge kvalitetskrav. Om et produkt til tross for dette skulle være feilaktig, ber vi deg vennligst ta kontakt med forhandleren. Vi ber deg medbringe kvittering og oppgi innkjøpsdato samt produktnummer.

FI TAKUU

Noudatamme alamme yleisiä toimitusehtoja.

Reklamaatio.

Tuotteemme ovat valmistettu Villeroy & Boch ja Gustavsbergin laatuvaatimuksien mukaisesti. Mikäli tuote kuitenkin on virheellinen pyydämme teitä kääntymään ensisijaisesti tuotteen myyjän puoleen. Käsittelyn helpottamiseksi säilyttäkää tosite tuotteen ostosta.

GB GUARANTEE

The product has a guarantee accordingly to industry rules in every country.

Instructions for complaints.

Our products are made according to very strict quality demands. If the product is faulty in spite of that we ask you kindly to take it to your reatailer. We also ask you to bring the receipt and be prepared to inform about the product number and purchasing date.

EE GARANTII

Antud tootel on garantii vastavalt tehase poolt kehtestatud tingimustele.

Juhised reklamatsioonide käsitlemiseks.

Meie tooted on valmistatud silmas pidades väga täpseid kvaliteedistandardeid. Juhul kui olete saanud praaktoote, palume Teil toimetada see kas meie edasimüüja juurde või võtta ühendust esindusega. Samuti palume alles hoida ostutšekk ning vajadusel anda informatsiooni tootenumbri ja ostu sooritamise aja kohta.

LV GARANTIJA

Izstrādājumam ir garantija saskaņā ar ražotāja standartiem.

Instrukcija kvalitātes problēmu gadījumā.

Mūsu produkcija tiek ražota pēc ļoti striktiem kvalitātes kritērijiem. Taču – gadījumā, ja produktam tiek konstatēta kvalitātes problēma – lūdzu, sazinieties ar pārdevēju. Lūdzu, esiet gatavi arī uzrādīt pirkuma čeku ar pirkuma datumu.

LT GARANTIJA

Gaminiamis garantija suteikiama atsižvelgiant į konkrečios šalies kokybės reikalavimus.

Reklamacijos.

Mūsų produkcija pagaminta vadovaujantis griežtais kokybės reikalavimais. Jei gaminys nekokybiškas – prašome jį gražinti pardavėjui, pateikiant pirkimo čekį, gaminio numerį bei nurodant pirkimo datą.

RU ГАРАНТИЯ

Гарантийные условия устанавливаются в соответствии с законами и правилами, которые действуют в стране сбыта.

Рассмотрение рекламаций.

Наша продукция соответствует современным стандартам и требованиям к качеству. В случае возникновения неисправности Вы можете обратиться в торговую организацию, где было приобретено данное изделие. При заявлении рекламации необходимо предъявить сопроводительные документы к данной продукции и чек, подтверждающий дату покупки.

CZ ZÁRUKA

Záruční doba je dána platnými předpisy v každé zemi.

Postup při reklamaci.

Naše produkty jsou vyráběny na základě přísných kvalitativních požadavků. Pokud výrobek vykazuje vadu, prosím obraťte se na Vašeho dodavatele. K dodavateli s sebou vezměte účet, na kterém je vyznačen kód výrobku a datum nákupu.

SK ZÁRUKA

Záručná doba je daná platnými predpismi v každej krajine.

Postup pri reklamácii.

Naše produkty sú vyrobené na základe prísnych kvalitatívnych požiadaviek. Ak výrobok vykazuje závalu, prosím obráťte sa na Vášho dodávateľa. K dodávateľovi so sebou vezmite účet, na ktorom je vyznačený kód výrobku a dátum nákupu.

NAUTIC 1500.
1546. 5500 &
5546

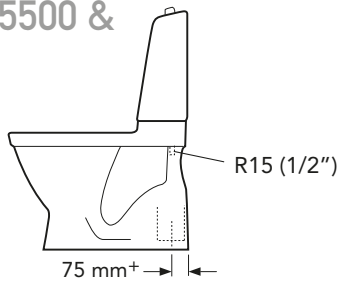

NAUTIC 1510 &
5510

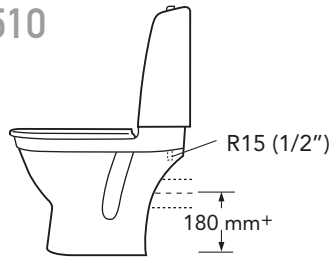

NAUTIC 1591.1596 &
5591

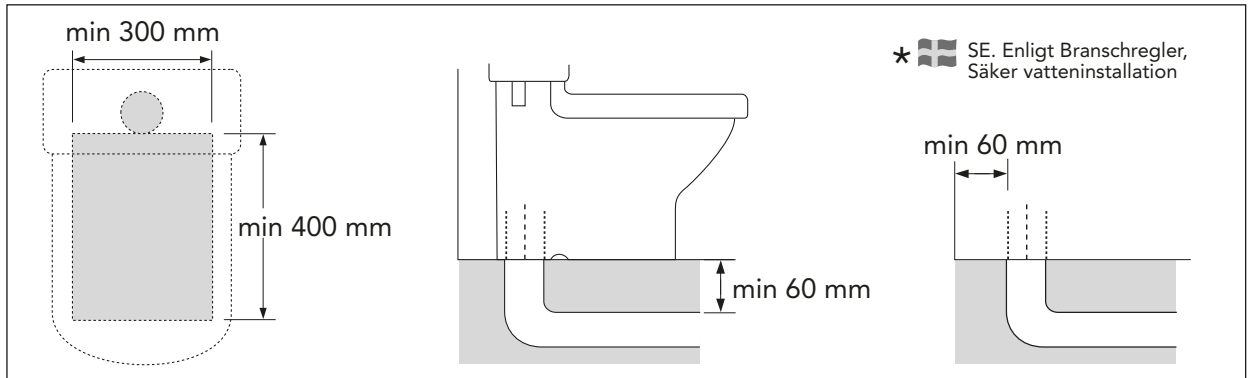
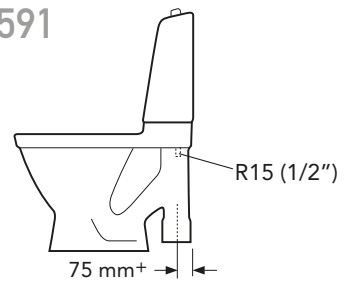

NAUTIC 5500 & 5510

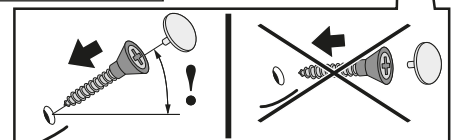
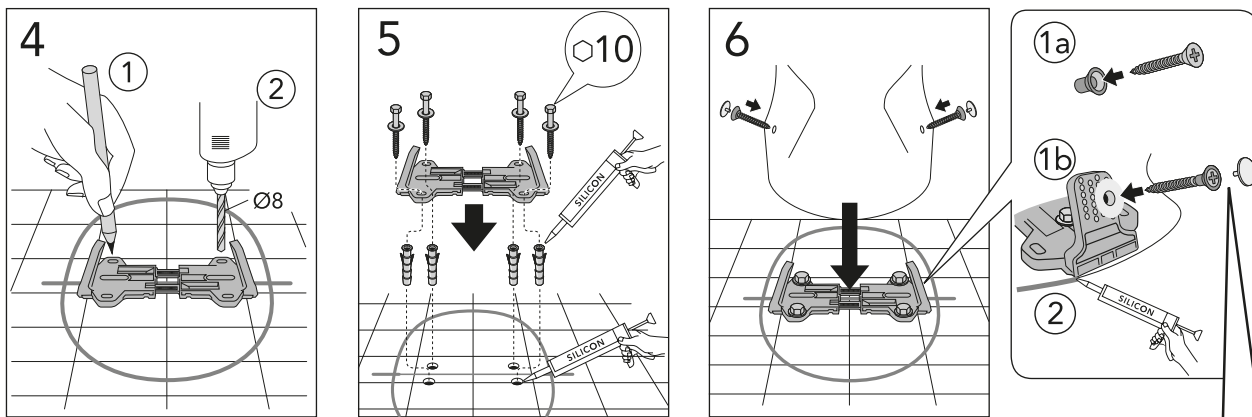
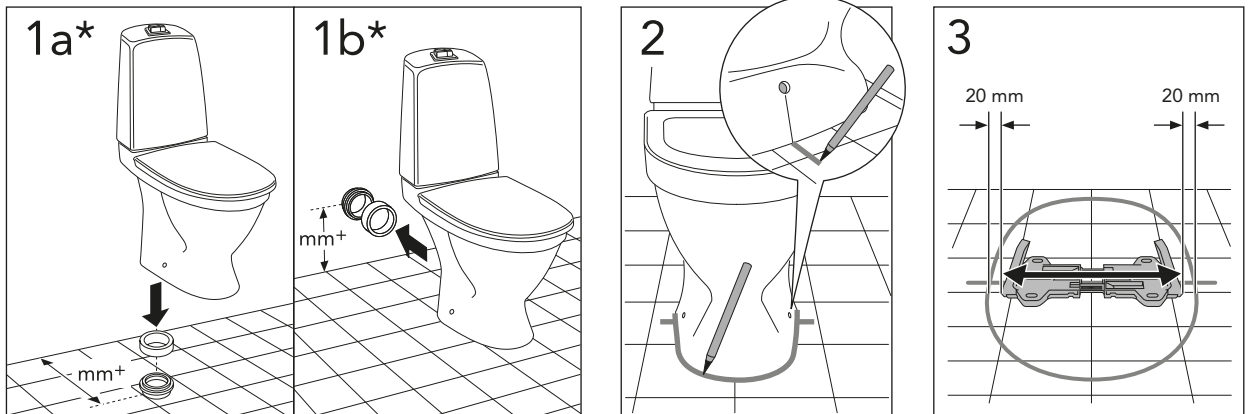



NAUTIC
5546
5591

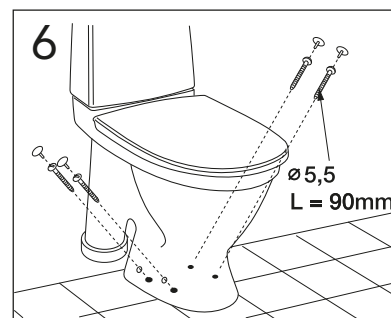
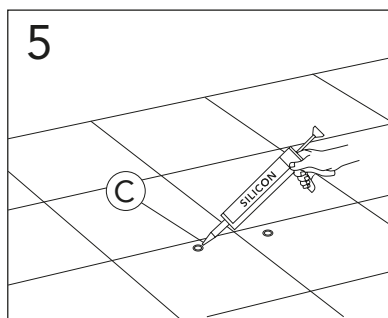
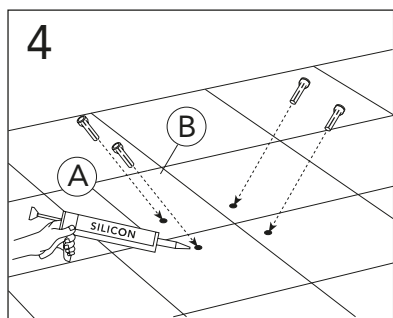
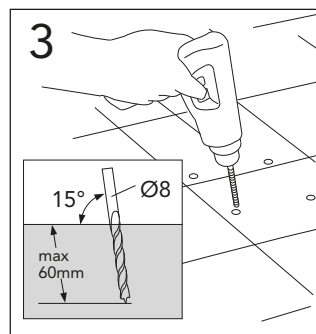
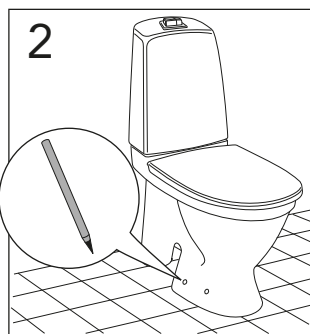



NAUTIC 1500. 1510. 1546. 1591.
1596. 5500. 5510. 5546 & 5591

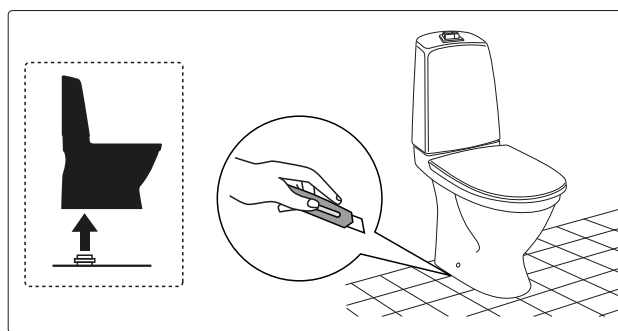
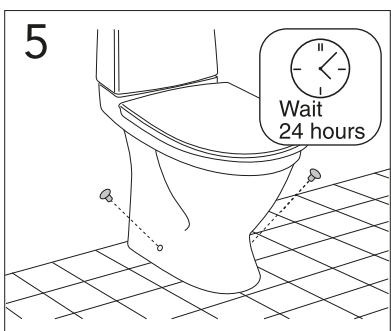
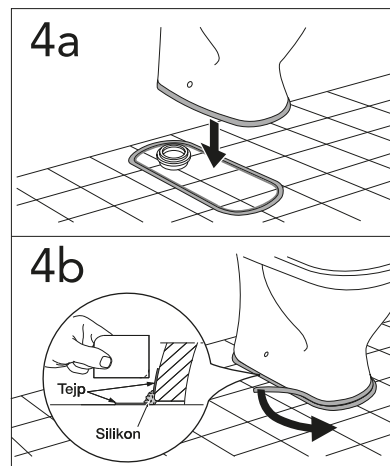
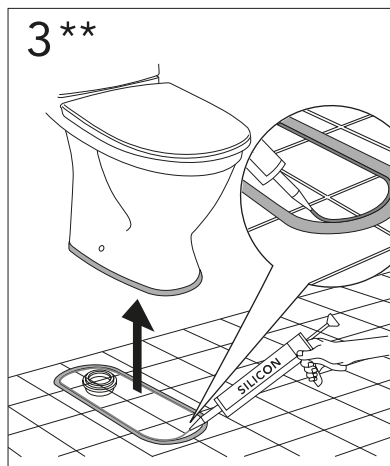
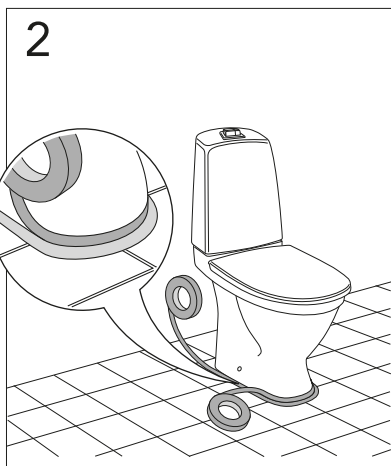
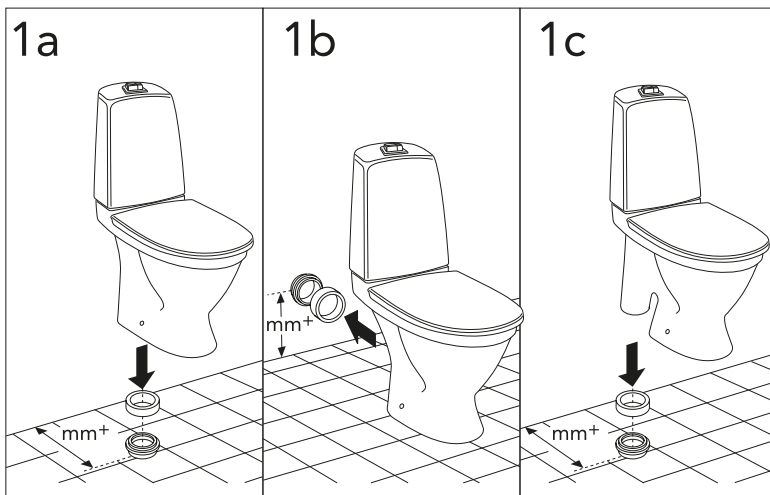
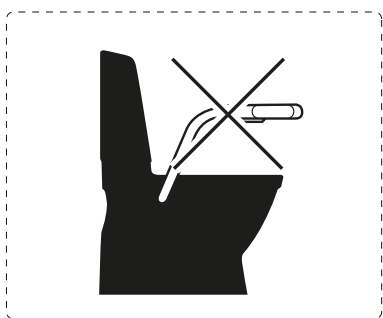
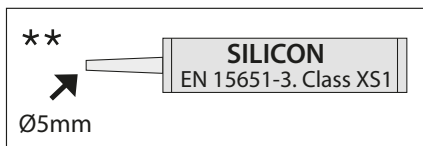

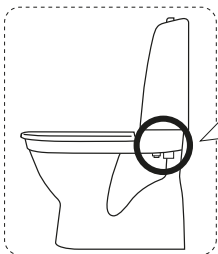

1

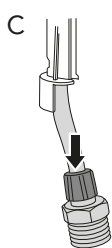
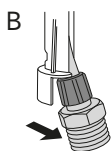
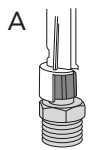

2

Alt. A

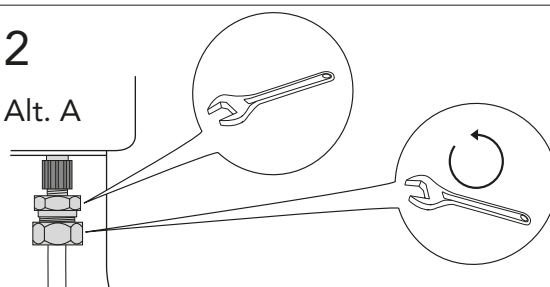

Alt. B

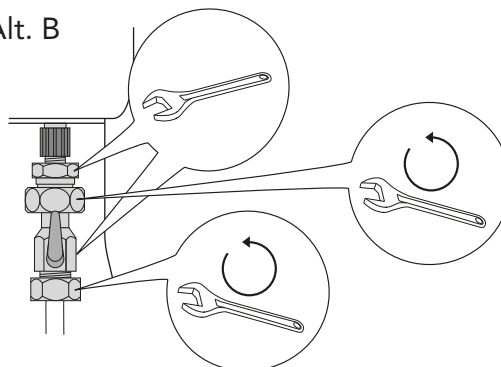

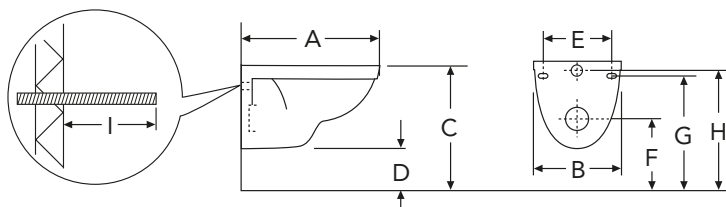
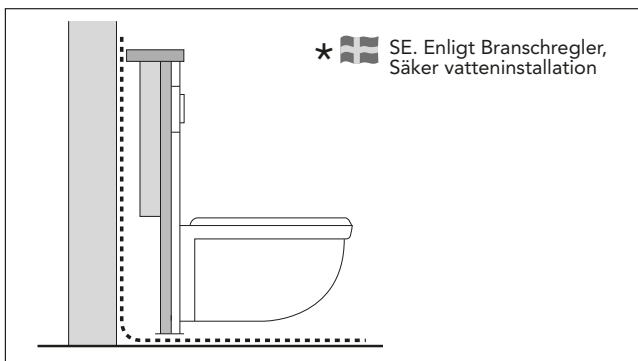

Models	A	B	C	D	E	F	G	H	I
5530	500	340	400	45	180/230	220	320	355	60



NAUTIC 5530

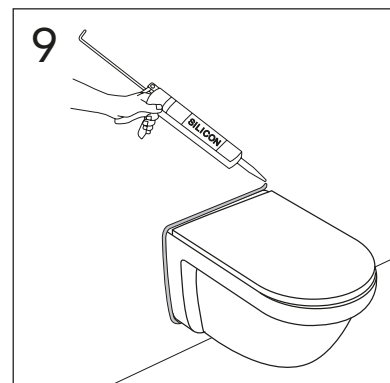
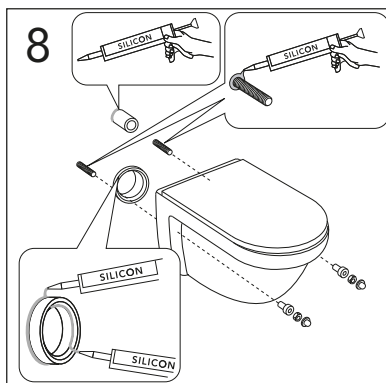
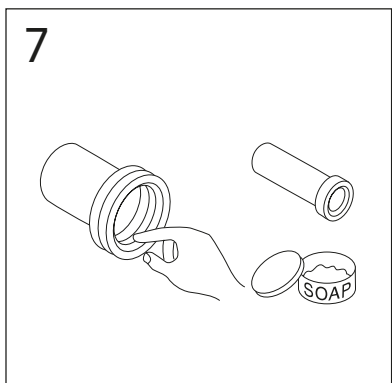
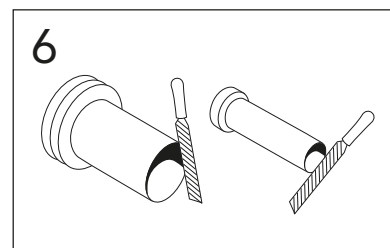
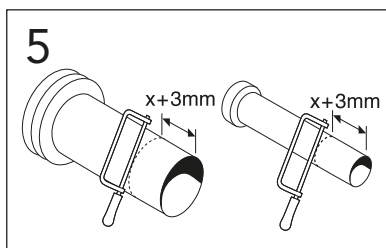
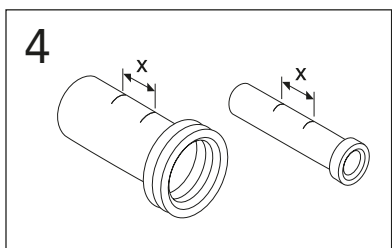
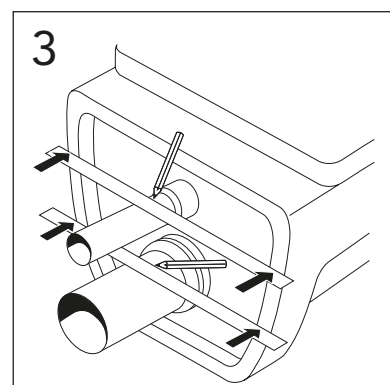
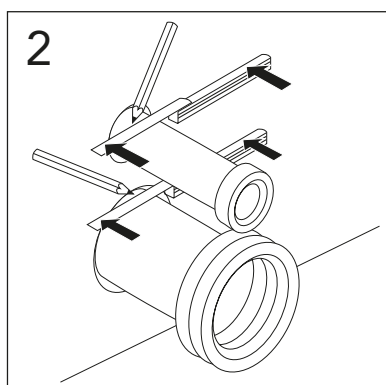
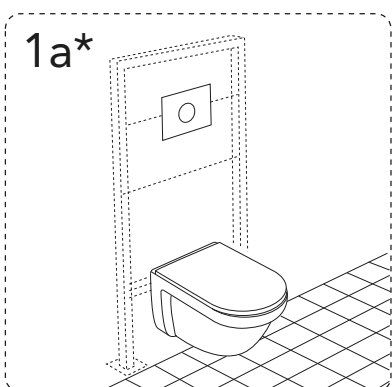



NAUTIC 5522

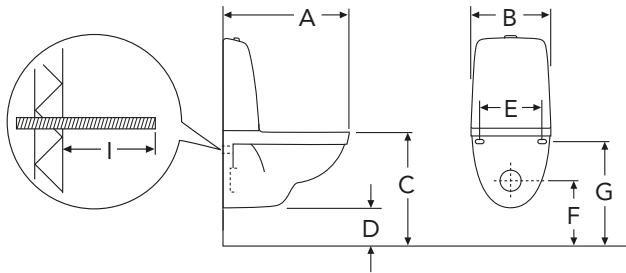
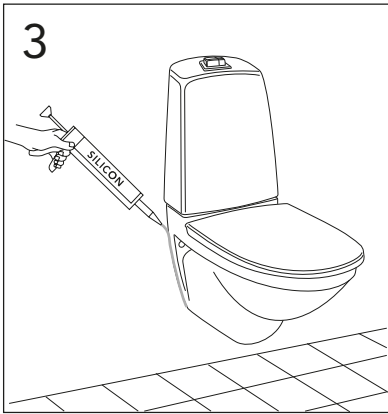
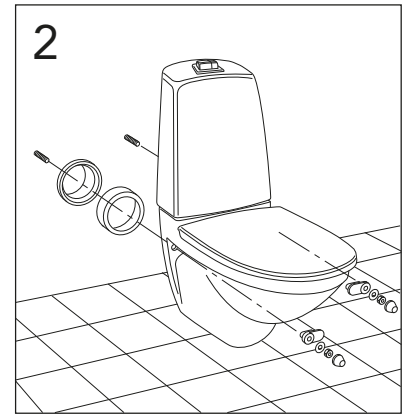
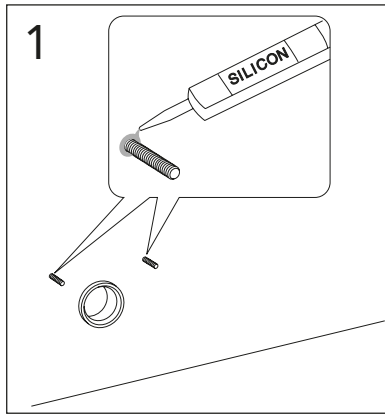
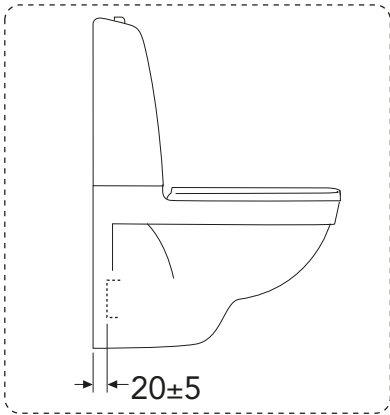

Models	A	B	C	D	E	F	G	I
1522 / 5522	700	345	400	50	180/230	220	320	60

NAUTIC 5599

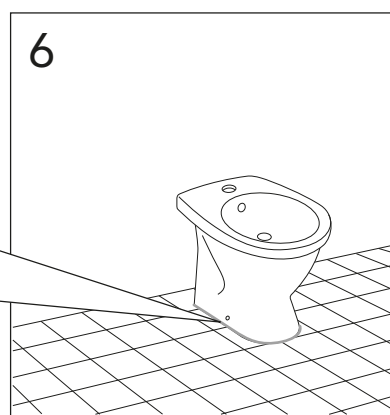
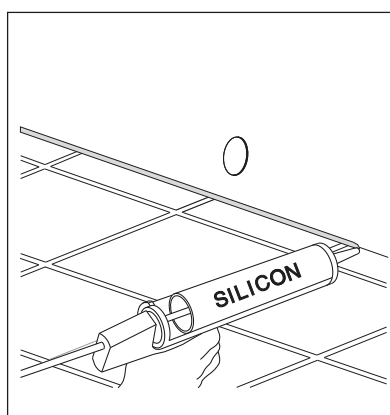
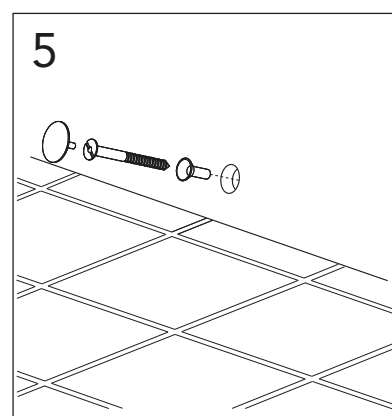
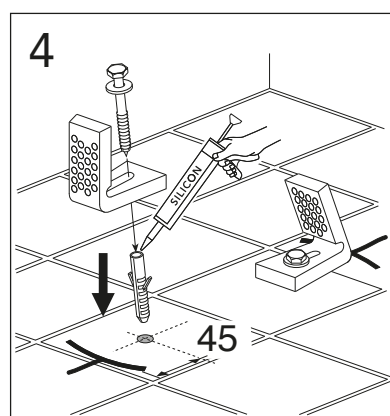
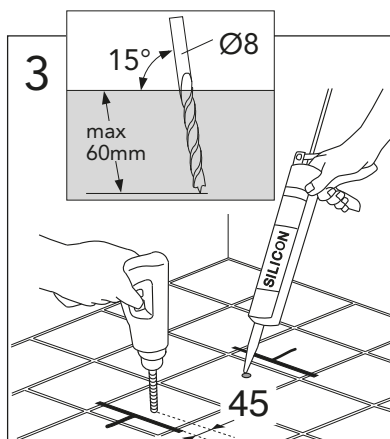
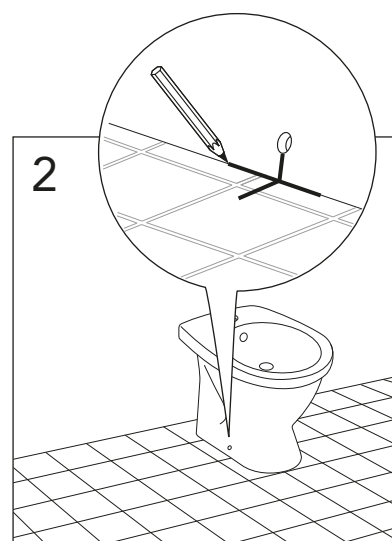
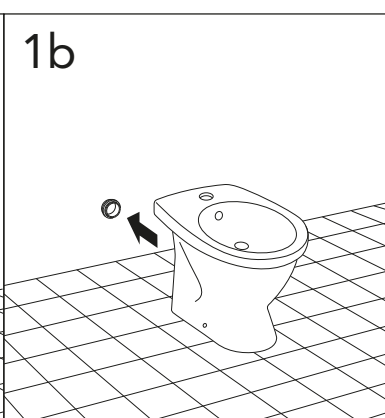
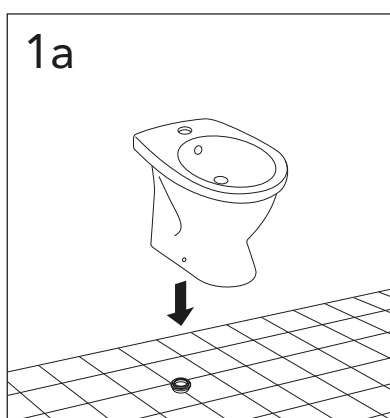
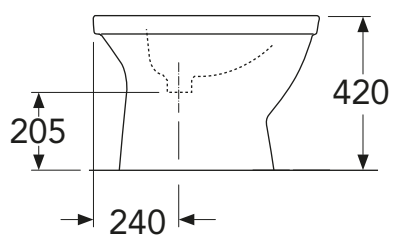

NAUTIC 5598

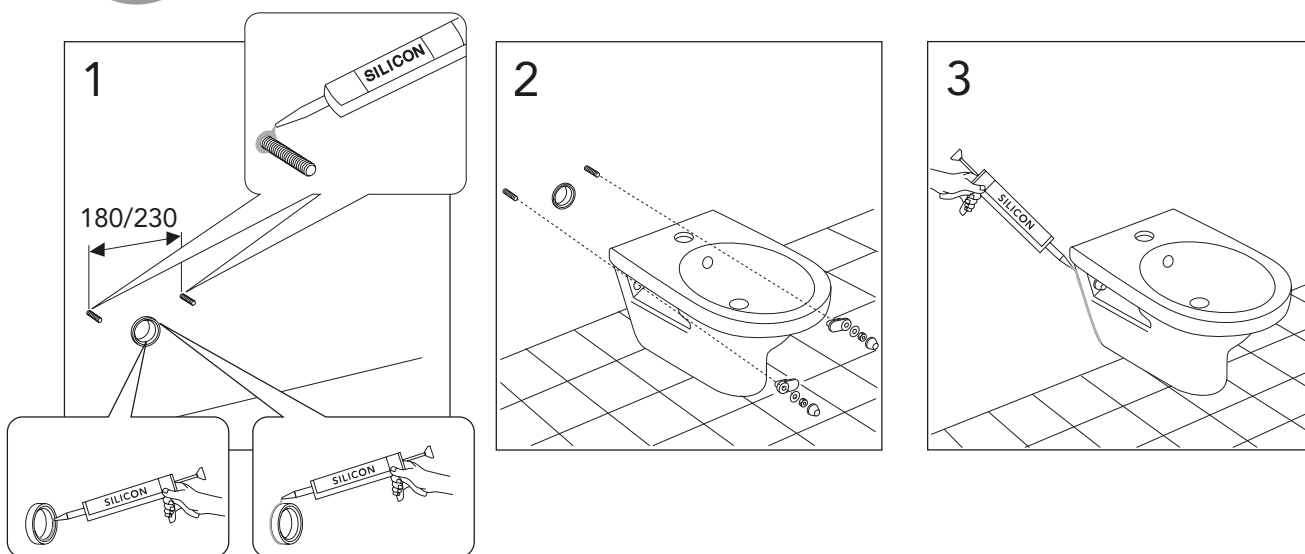
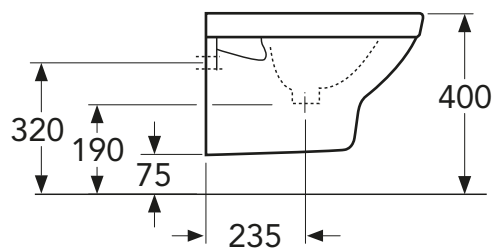

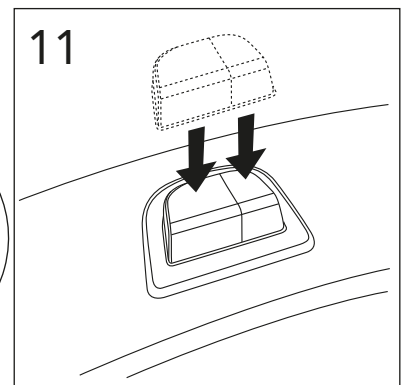
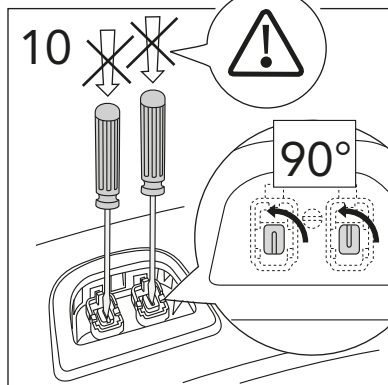
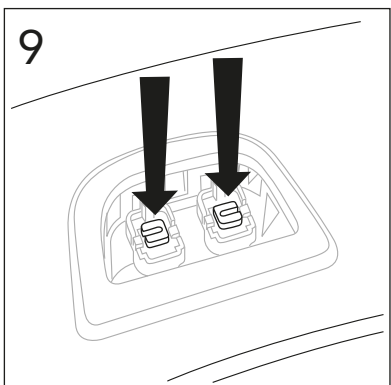
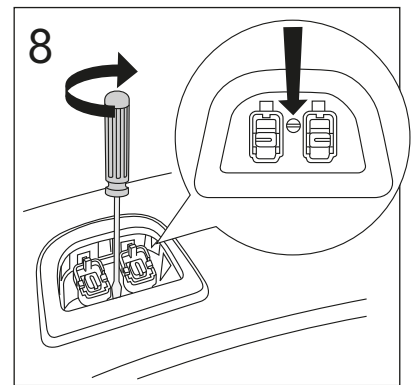
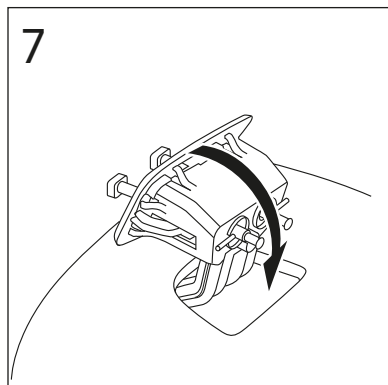
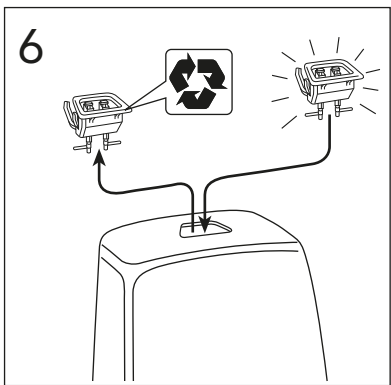
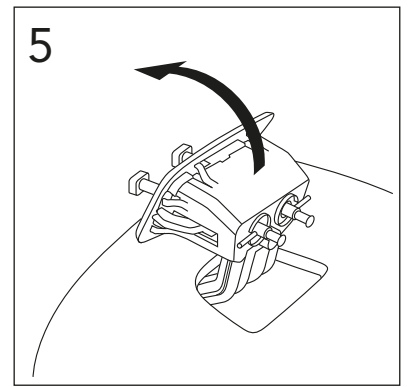
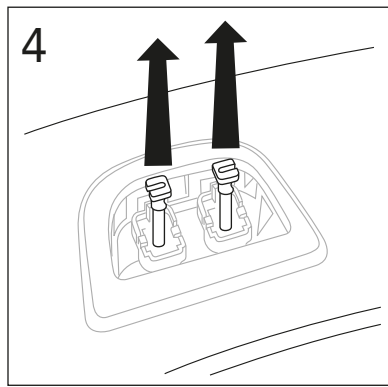
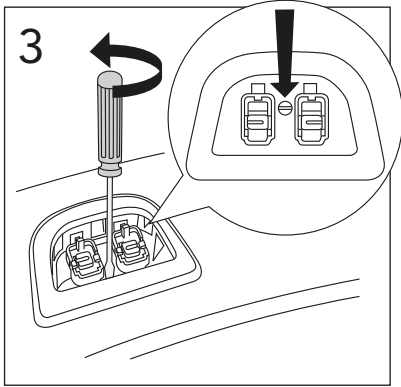
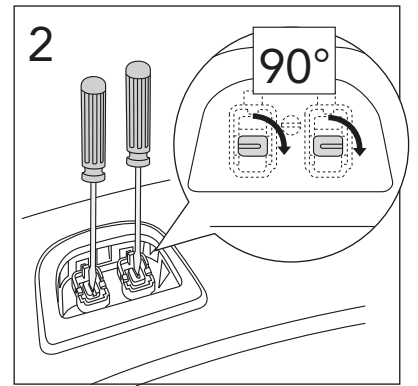
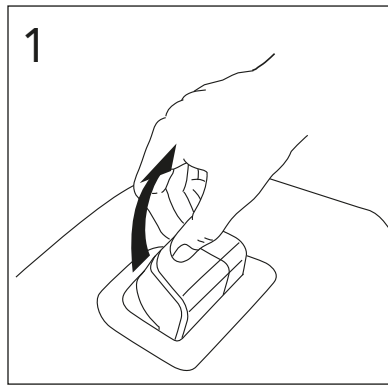
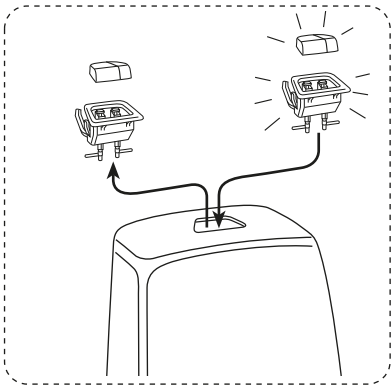

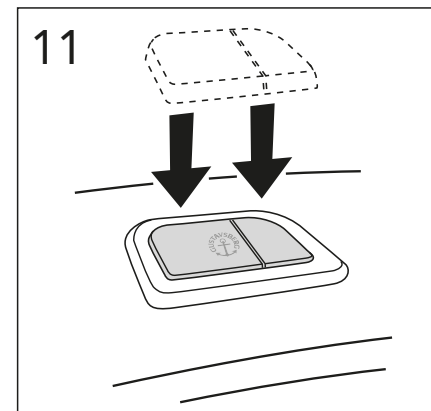
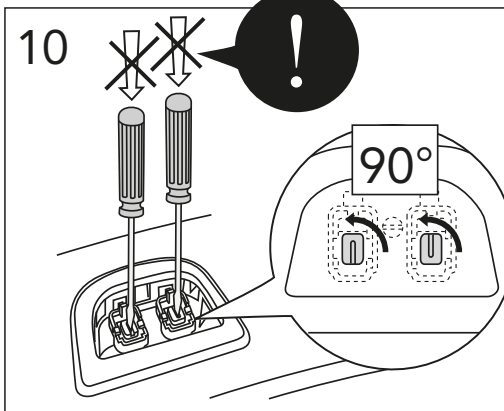
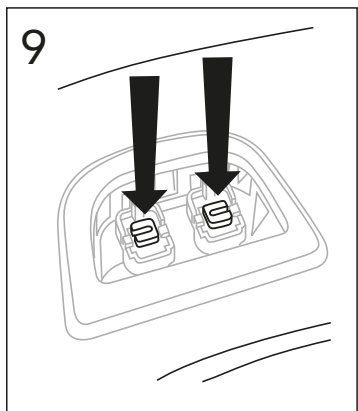
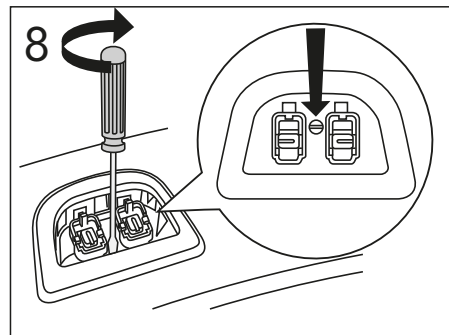
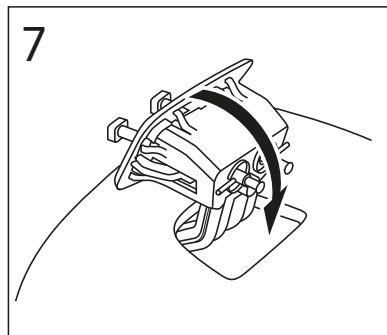
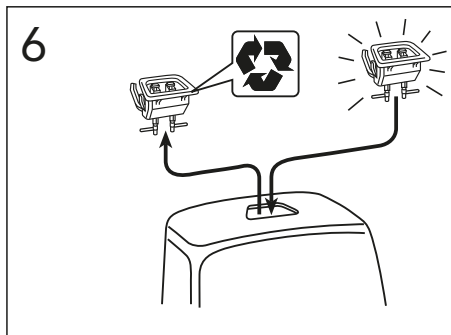
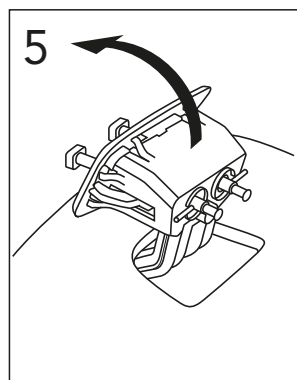
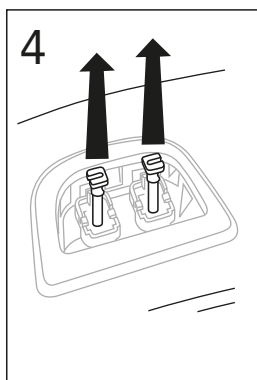
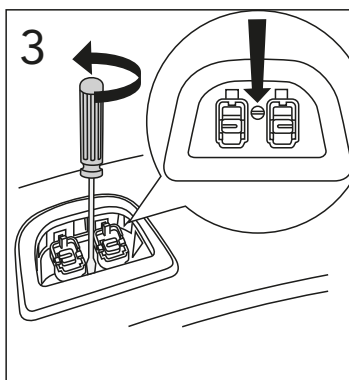
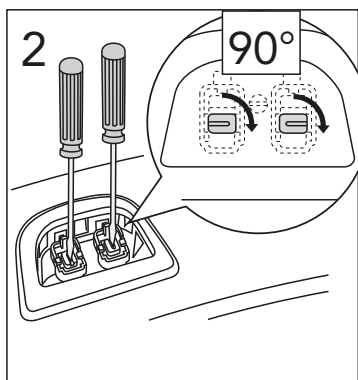
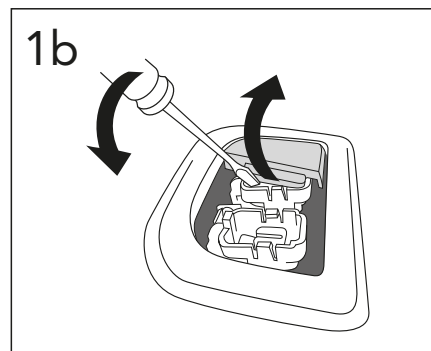
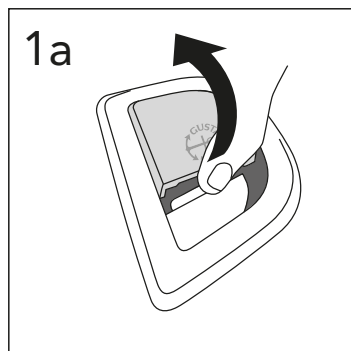
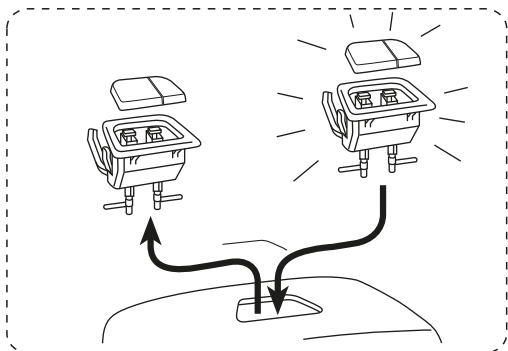



NAUTIC

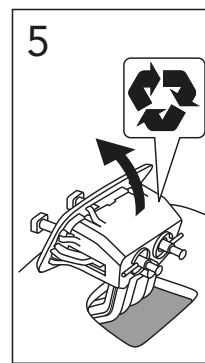
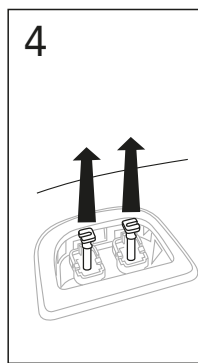
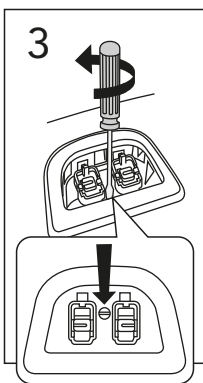
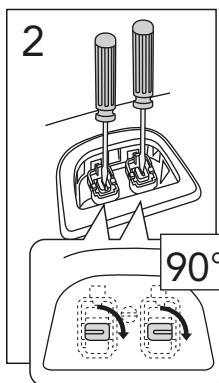
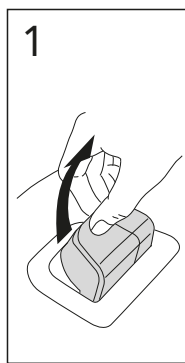
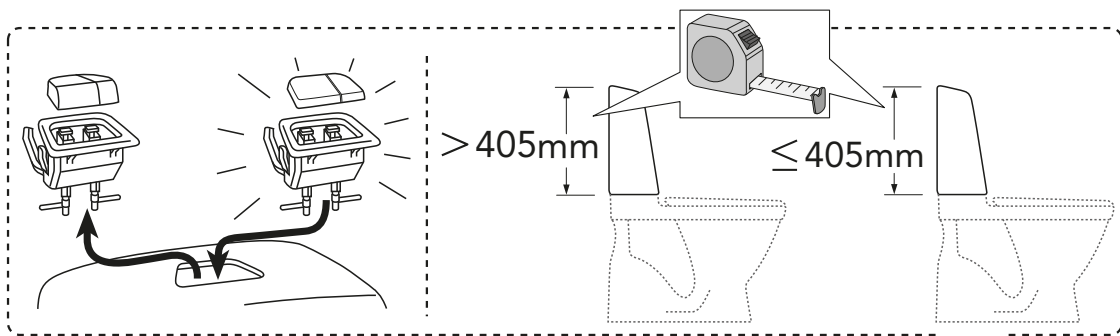

> 405mm

≤ 405mm

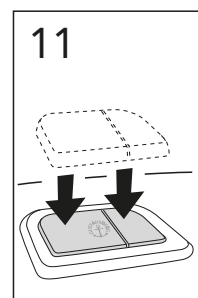
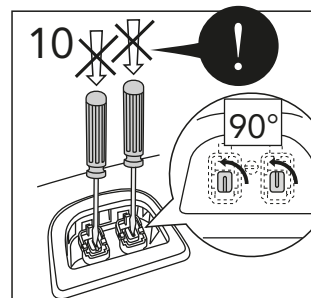
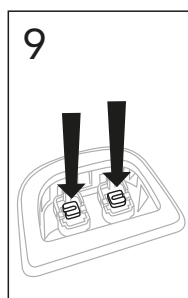
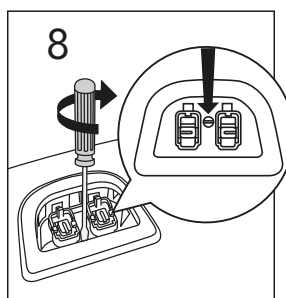
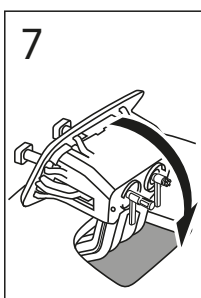
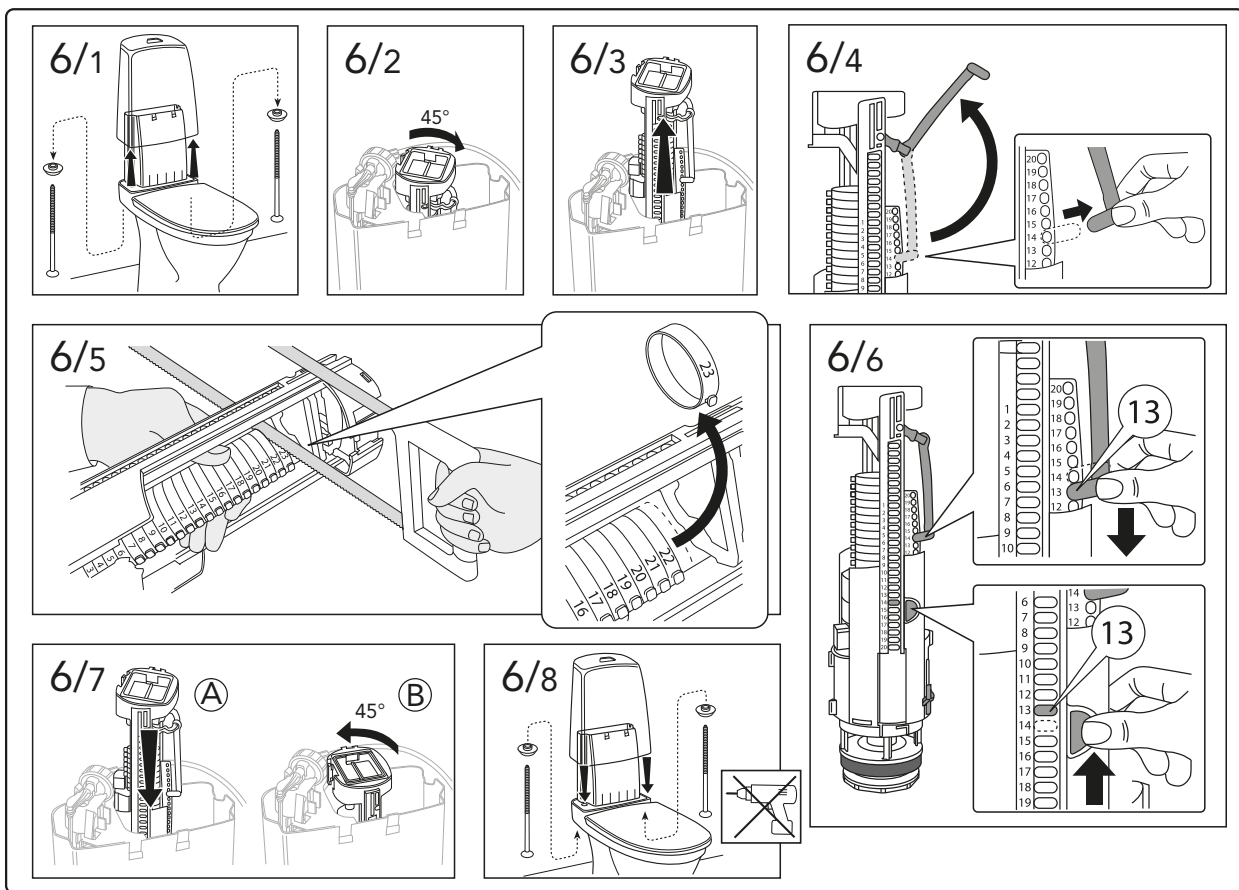



i  SE

Provtryckning mot stängd avstängningsventil max 16 bar

Drifttryck 0,5-10 bar (Påfyllningsventil)



OFF

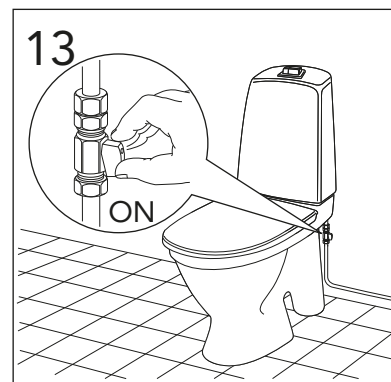
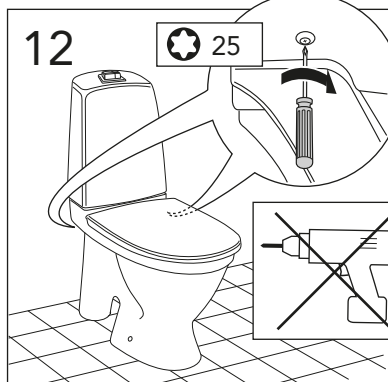
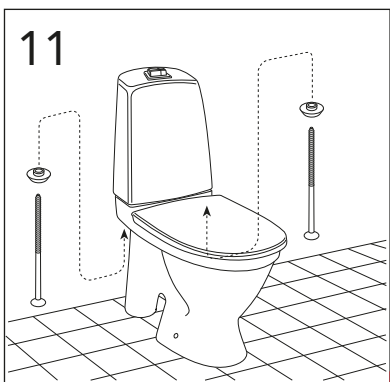
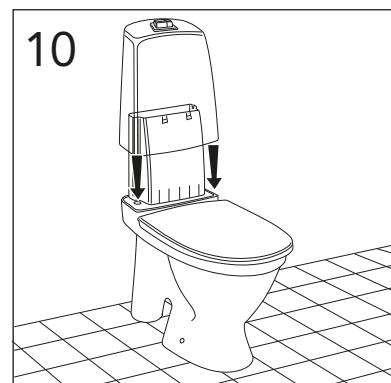
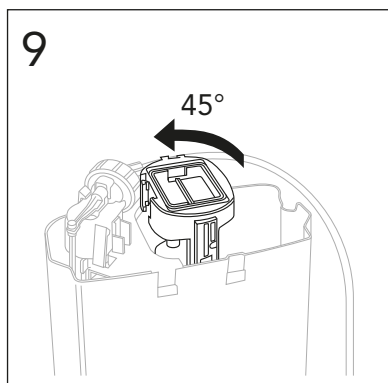
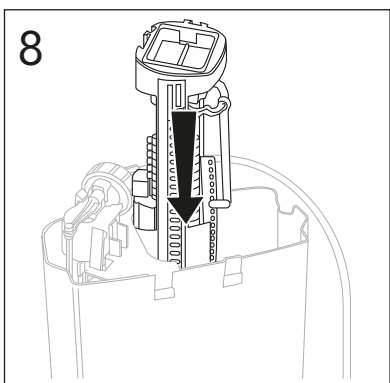
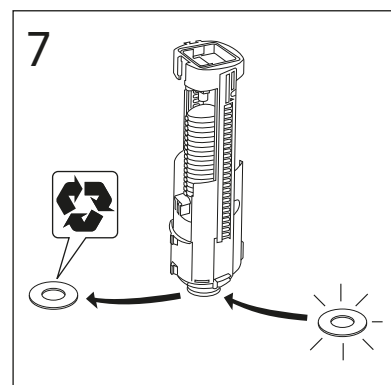
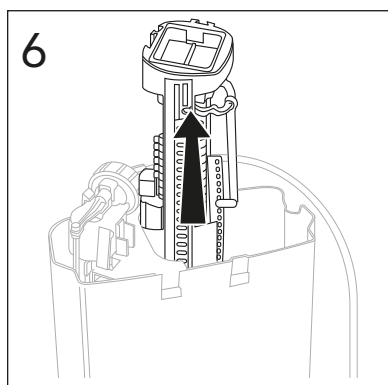
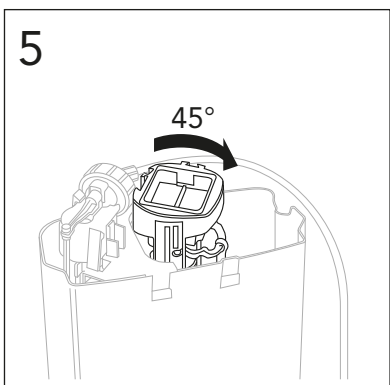
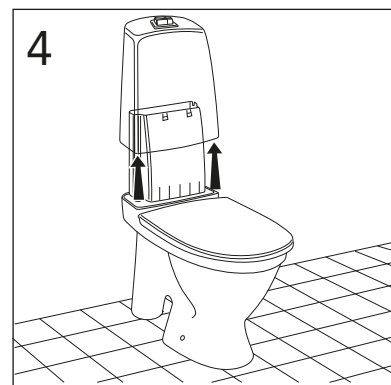
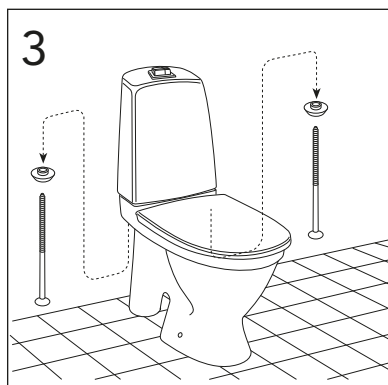
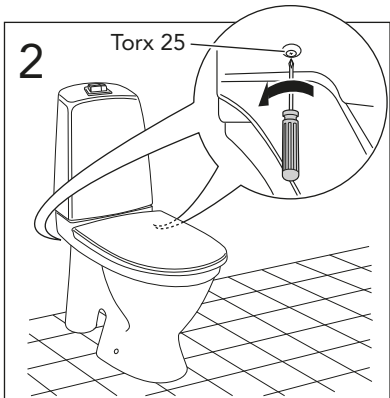
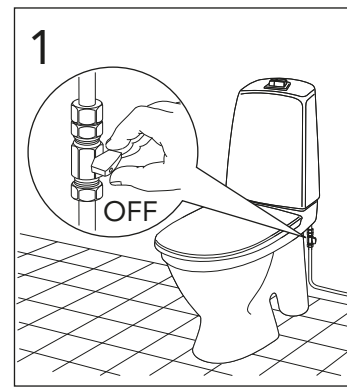
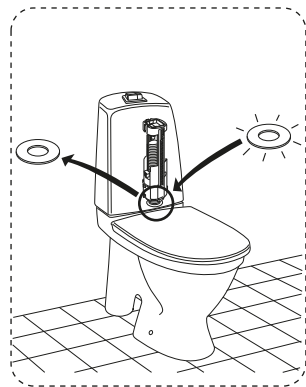

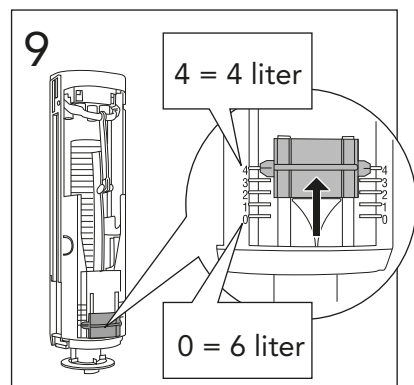
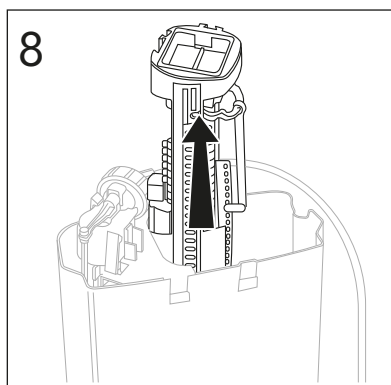
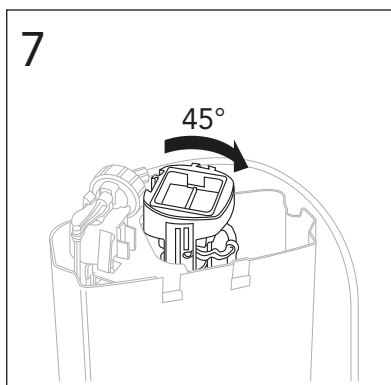
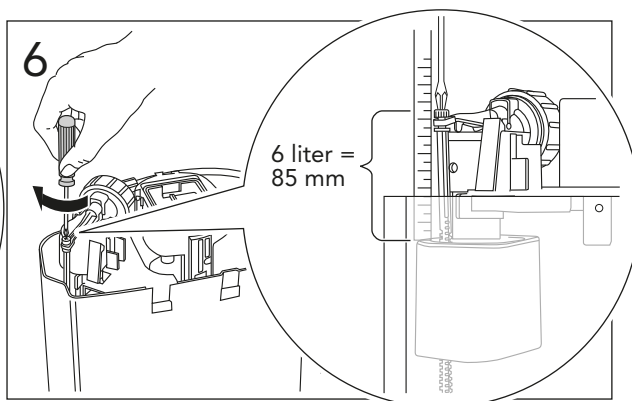
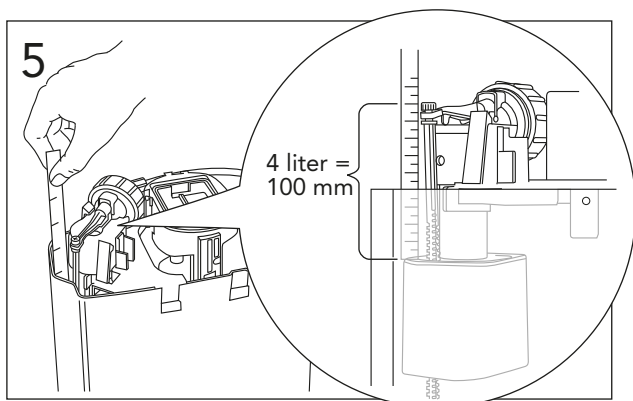
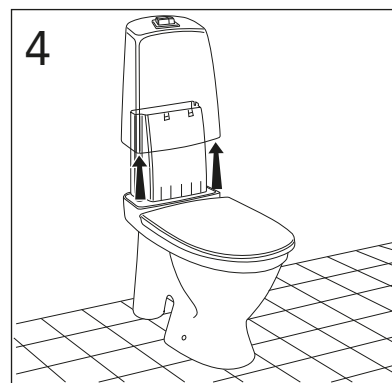
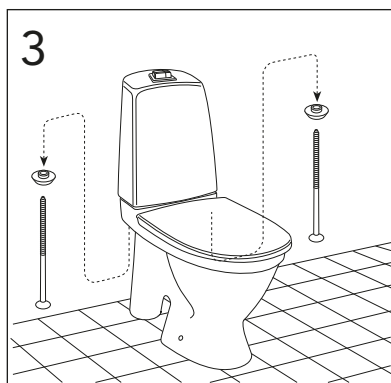
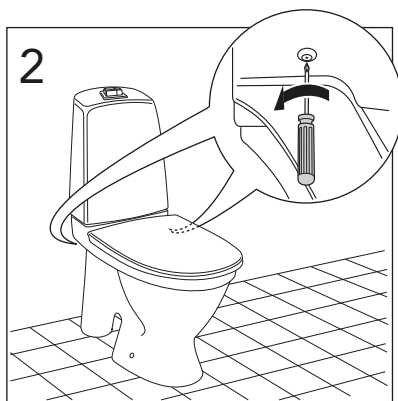
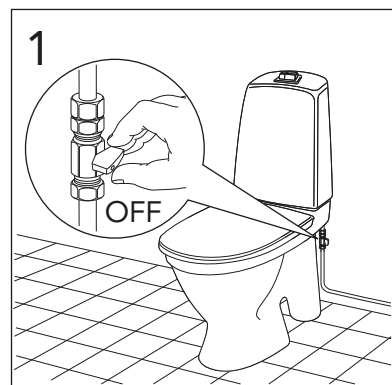
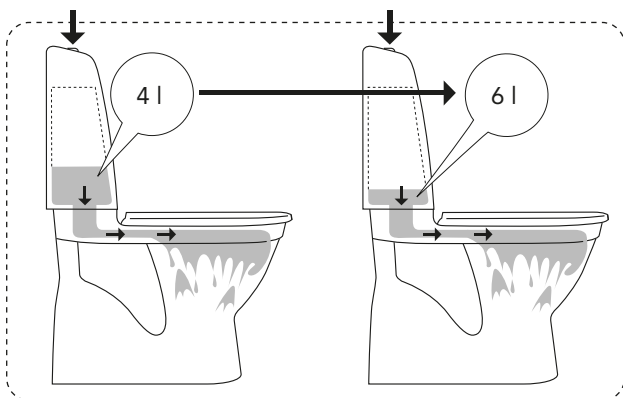

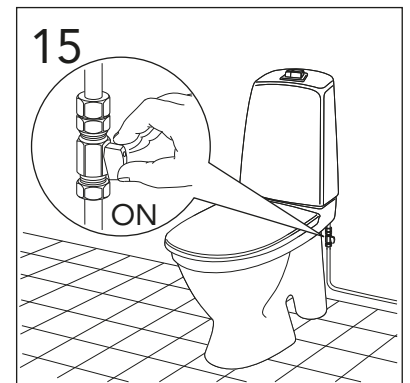
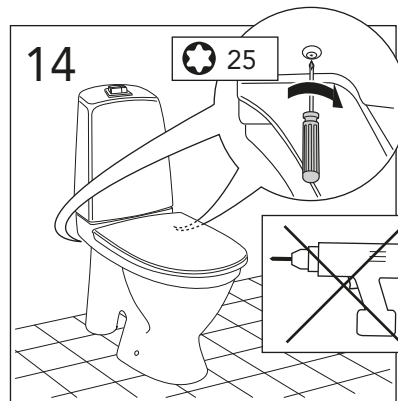
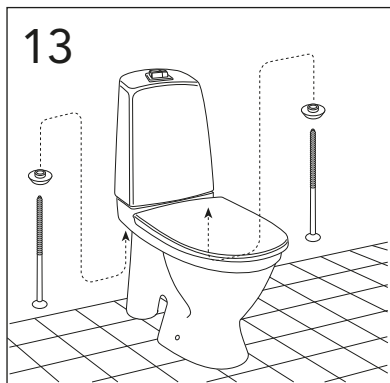
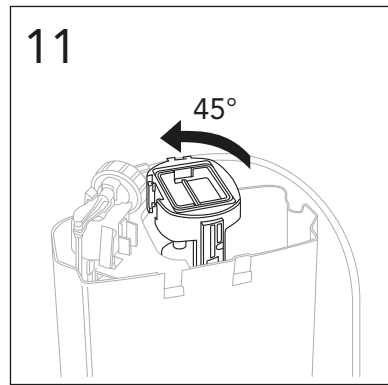
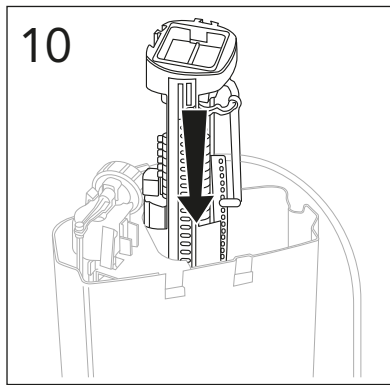

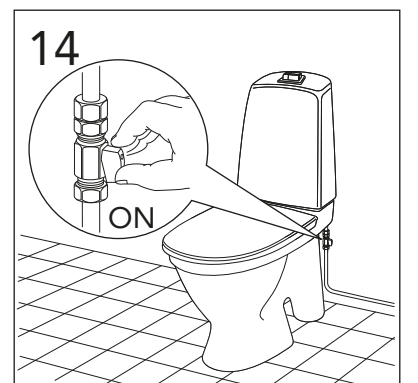
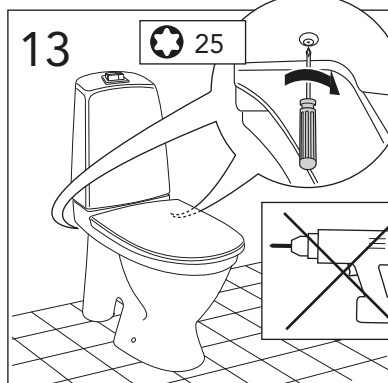
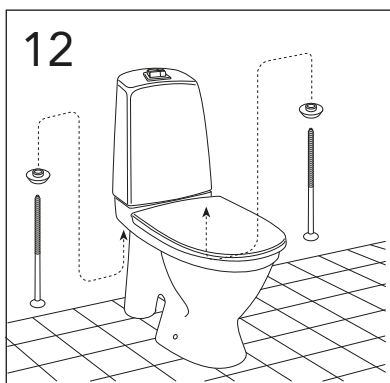
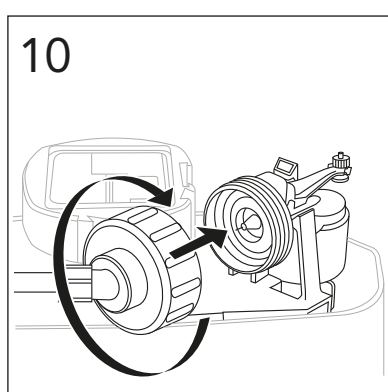
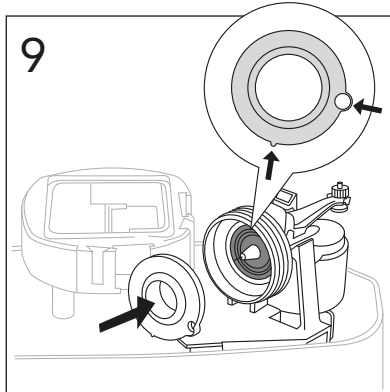
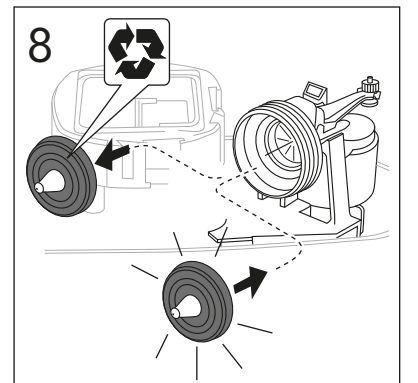
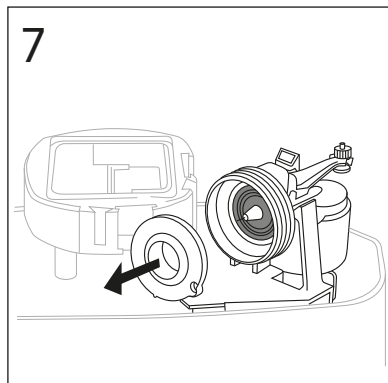
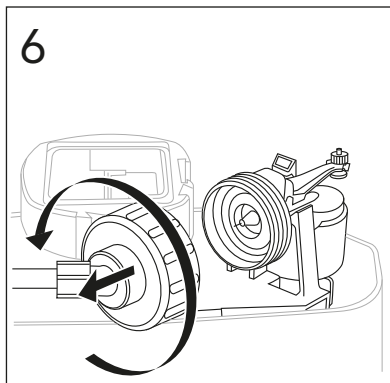
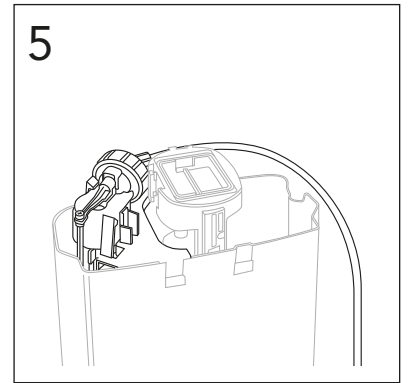
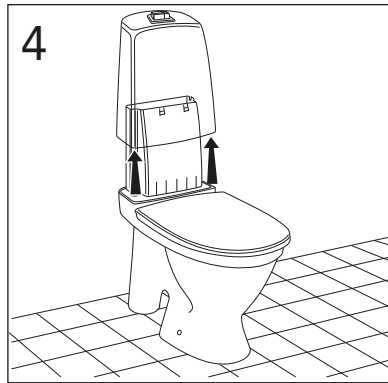
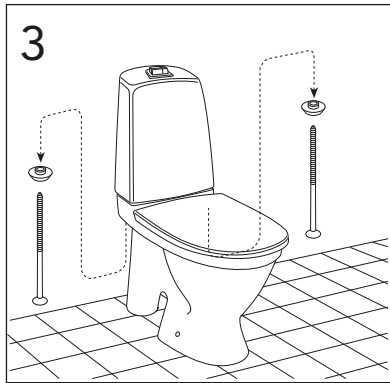
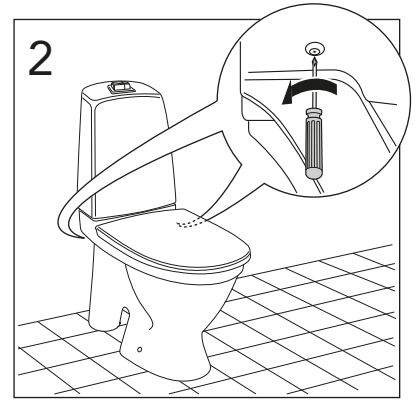
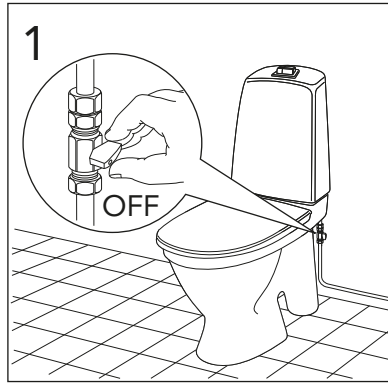
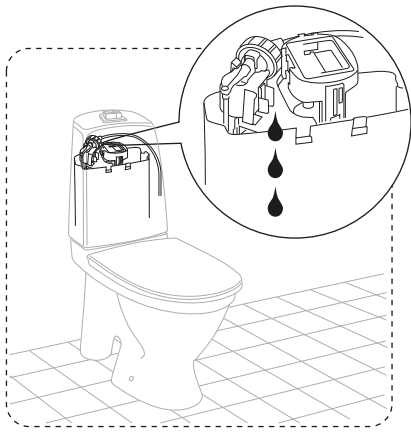

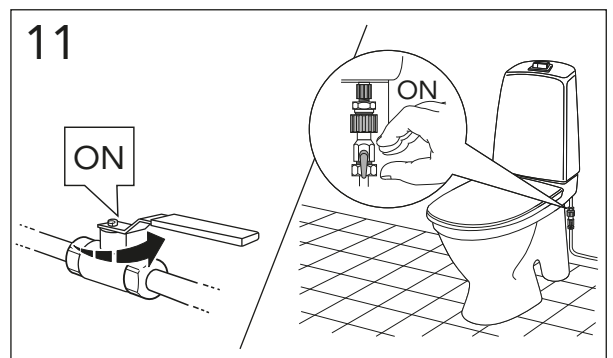
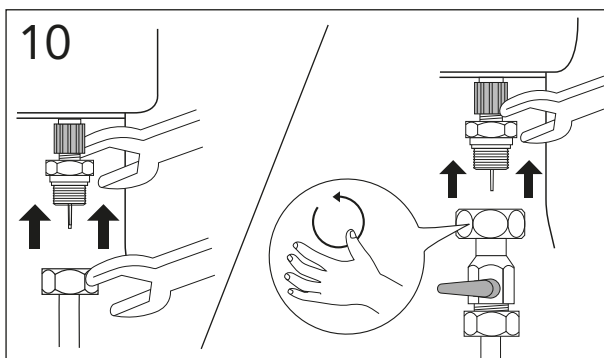
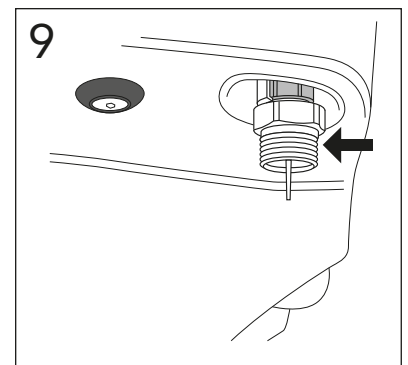
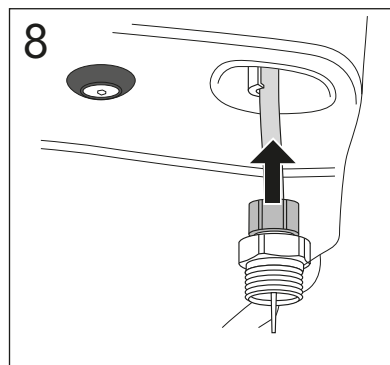
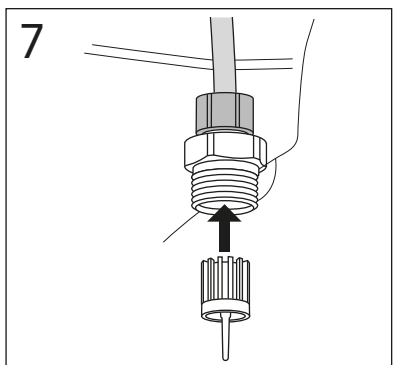
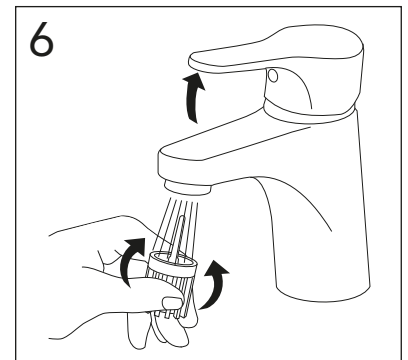
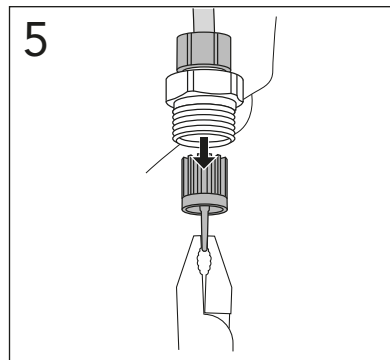
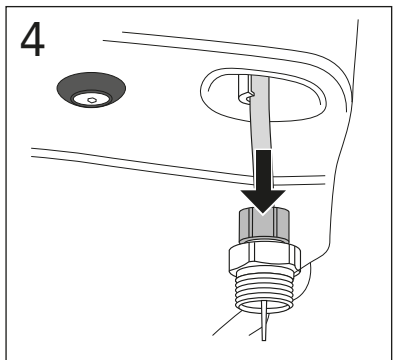
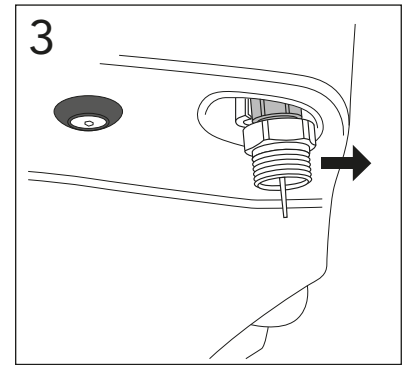
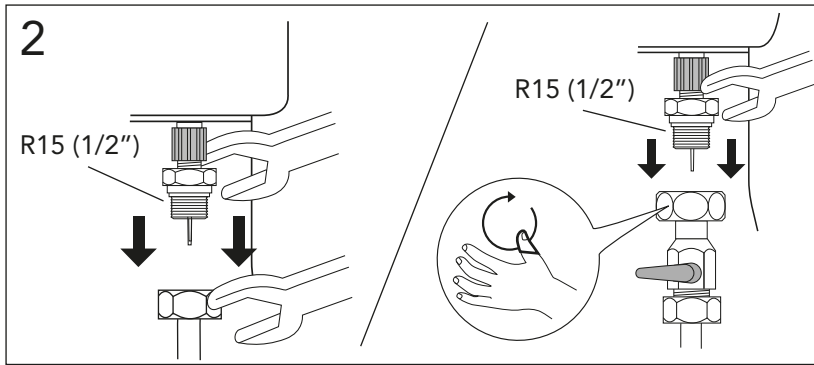
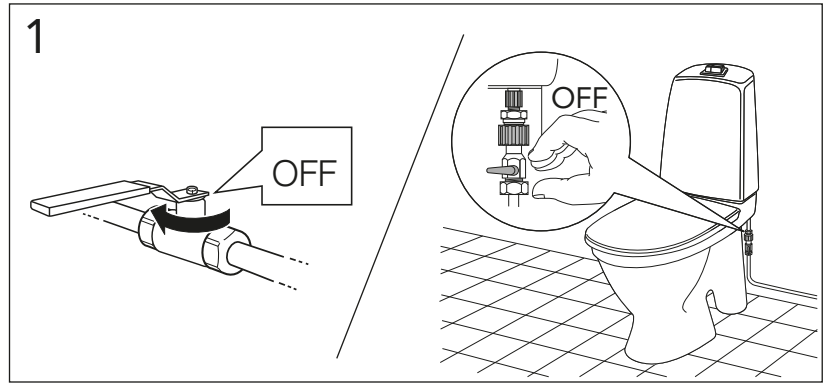
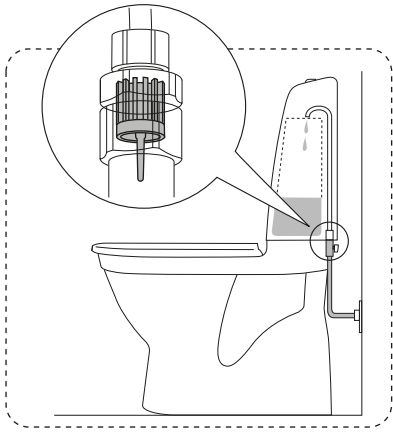



9M26S101. 9M26S136

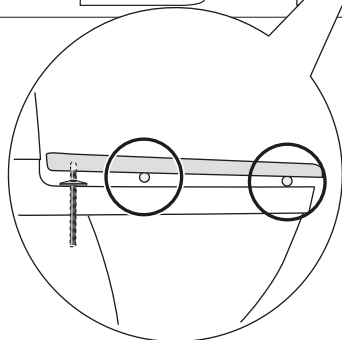
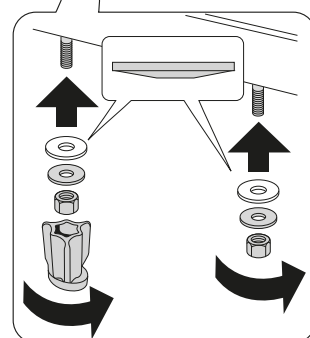
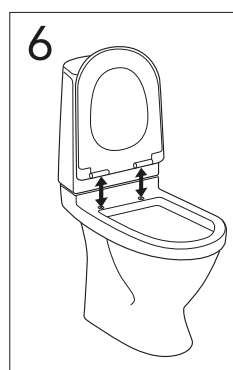
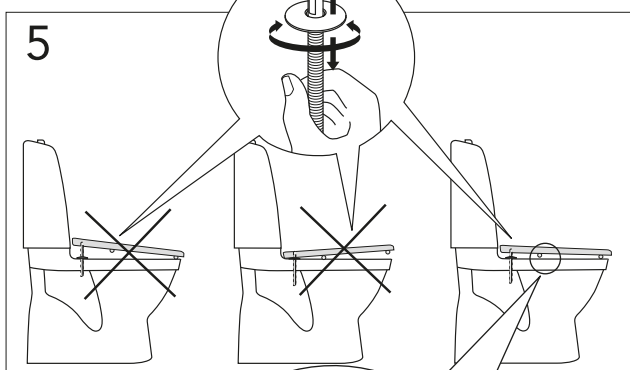
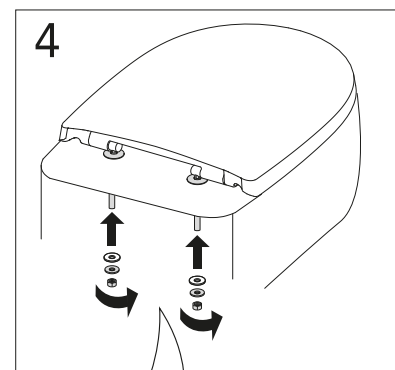
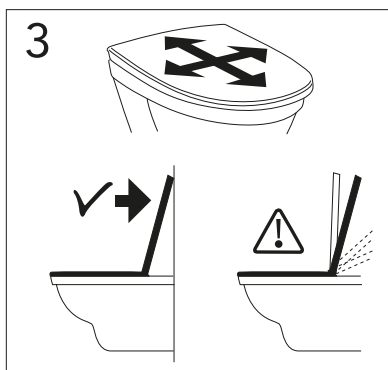
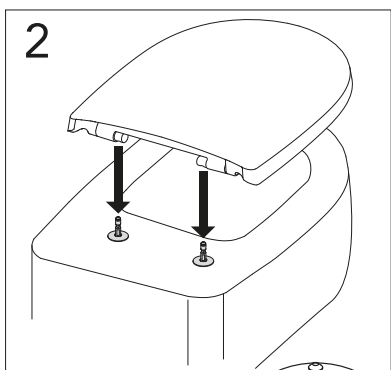
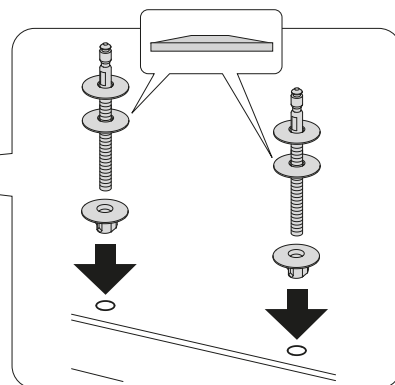
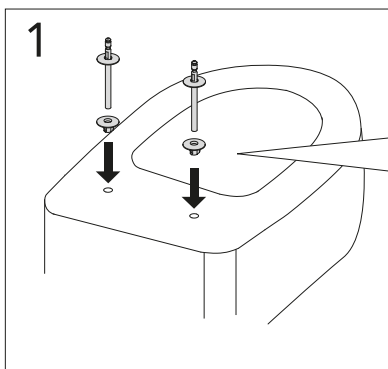



9M256101

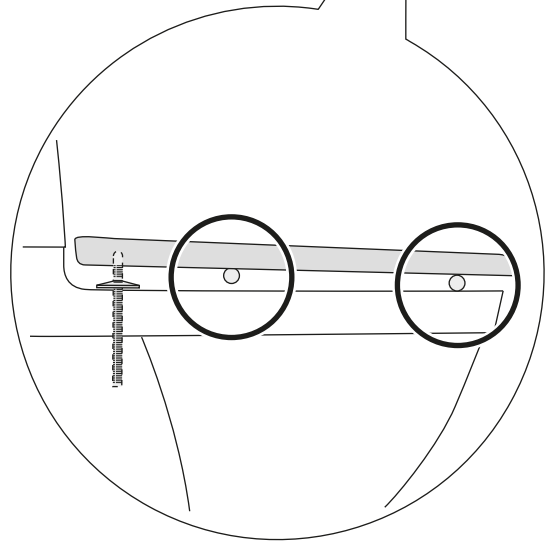
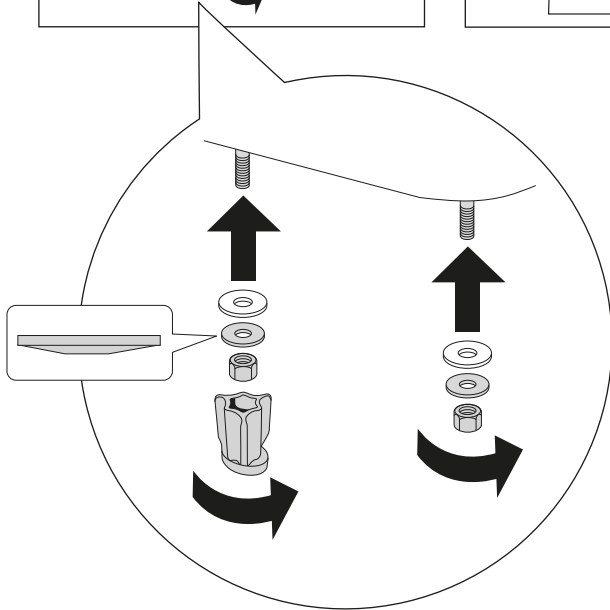
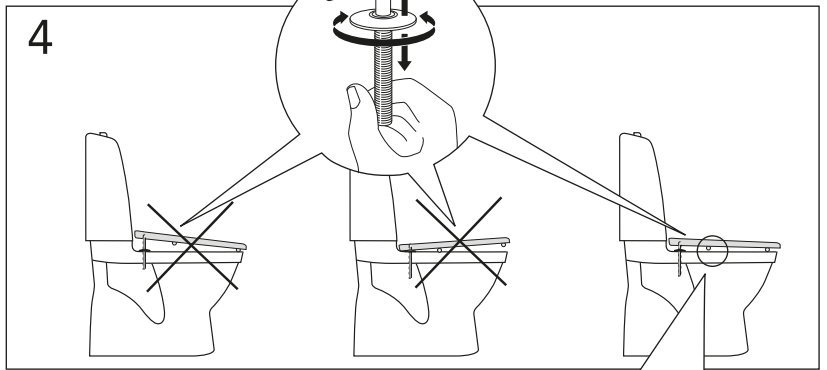
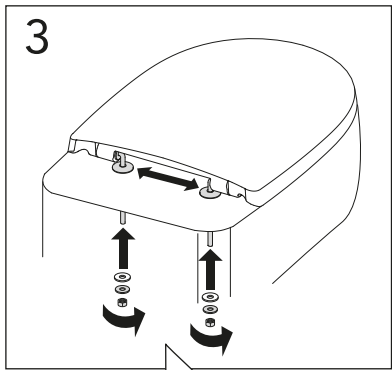
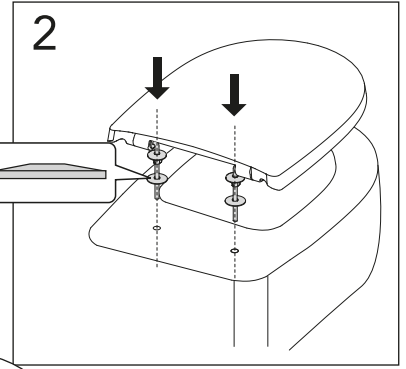
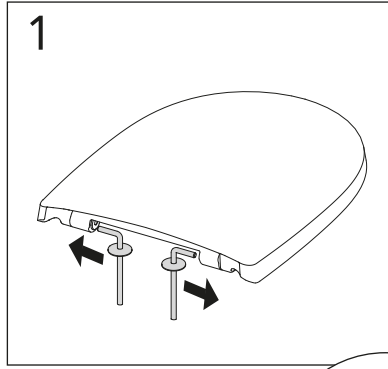
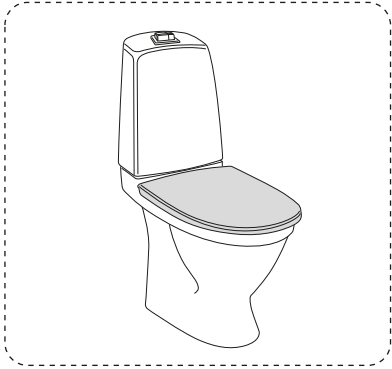

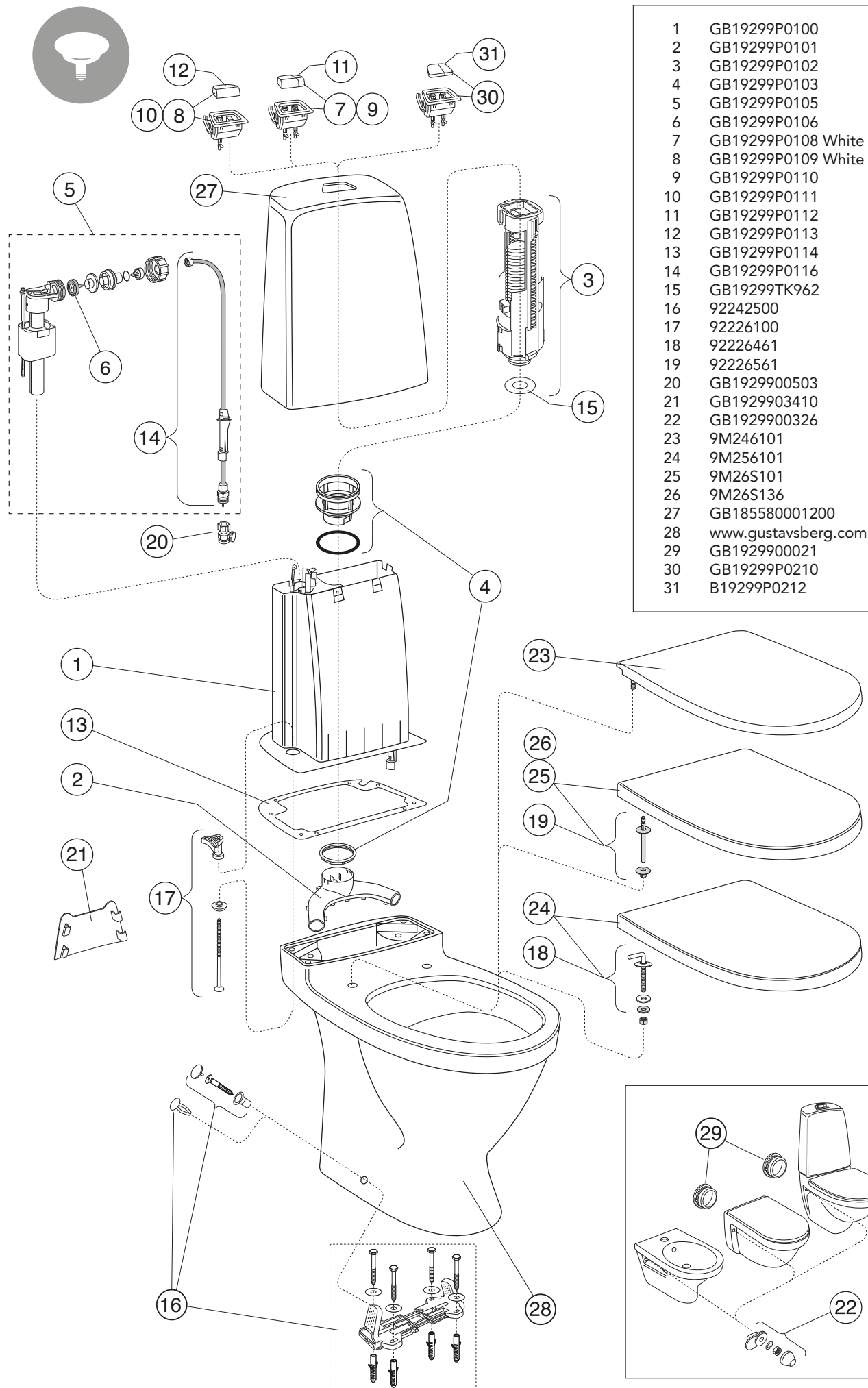



www.gustavsberg.com



Sweden / Sverige

English

Denmark / Danmark

Finland / Suomi

Norway / Norge

Estonia / Eesti

Russia / Россия

Latvia / Latvija

Lithuania / Lietuva

Ukraine / Україна

SKÖTSEL AV PORSLINSPRODUKTER
 RENGØRING OG PLEJE AF SANITETSPRODUKTER
 VEDLIKEHOLD AV SANITÆRPORSELEN
 KÄYTTÖ- JA HOITO-OHJE, POSLIINITUOTTEET
 MAINTENANCE OF CERAMIC PRODUCTS
 KERAAMIKATOODETE HOOLDAMINE
 KOPŠANAS INSTRUKCIJA KERAMIKAS PRODUKTIEM
 KERAMIKOS GAMINIŲ PRIEŽIŪRA
 Установка керамических изделий
 ÚDRŽBA VÝROBKŮ Z KERAMIKY
 ÚDRŽBA VÝROBKOV Z KERAMIKY

LANGUAGE



SUPPORT



A MEMBER OF THE
 VILLEROY & BOCH GROUP

Sweden
 Villeroy & Boch Gustavsberg AB
 Box 400
 134 29 Gustavsberg
 Phone +46 8 570 391 00
 info@gustavsberg.com

Norway
 Villeroy & Boch Norge AS
 Luhrtoppen 2
 Postboks 13
 1471 Lørenskog
 Tlf. + 47 67 97 82 50
 info.norway@gustavsberg.no

Estonia
 Villeroy & Boch Gustavsberg Oy Eesti Filiaal
 F. R. Faehmanni 6
 10125 Tallinn
 Telefon +372 646 0312
 E-mail: info@gustavsberg.ee

Lithuania
 Villeroy & Boch Gustavsberg Oy Filialas
 Maironio 25-23,
 Vilnius LT-01125
 Tel.: +370 5 2460811
 El.paštas: info.lt@gustavsberg.com

Russia
 ООО "Виллерой и Бох"
 127287 Москва
 ул. 2я Хуторская, д.38А/9
 Тел.: +7 495 609 6560
 info.russia@gustavsberg.com

Denmark
 Villeroy & Boch Danmark A/S
 Hvidsværmervej 165 G
 2610 Rodovre
 Tlf + 45 36 70 80 55
 info@gustavsberg.dk

Suomi/Finland
 Villeroy & Boch Gustavsberg Oy
 Laippatie 14 b
 00880 Helsinki
 Puh 09 329 18 811
 myynti@gustavsberg.com

Latvia
 Villeroy&Boch Gustavsberg Oy parstavnieciba Latvija
 Krasta iela 68 A
 LV - 1019 Riga. Latvija
 Tālrunis: +371 6724 5511
 e-pasts: info.latvia@gustavsberg.com

Україна
 Представництво Villeroy & Boch Gustavsberg в Україні
 вул. Богдана Хмельницького 17/52а, оф. 401а,
 м. Київ, 01030
 тел: +38044 493 98 68
 info@gustavsberg.kiev.ua

Czech Republic / Slovakia
 Villeroy & Boch Czech s.r.o
 Türkova 2319/5b
 149 00 Praha 4 - Chodov
 Czech Republic
 Tel: +420 271 001 647
 info-cz@villeroy-boch.com