



Brad type: F16 (16 Gauge) 20° Angled Brads
 Wire Ø: 1.60mm



Suitable for the following tools*:

Paslode FN16A 65
 IM65A F16 (Lithium)
 IM250A

**please check staple length compatibility with each tool before use*

Brad lengths available: 32mm – 64mm
 Brads per strip: 50

CORROSION PROTECTION

Finish	Usage Environment	Label Colour on Packaging
Zinc Galv	INDOOR 	Blue
Stainless Steel A2 AISI 304 / WNr 1.4301	INDOOR, COVERED OUTDOOR & OUTDOOR 	Yellow
Stainless Steel A4 AISI 316 / WNr 1.4401	INDOOR, COVERED OUTDOOR & OUTDOOR 	Yellow

BRAD PROPERTIES / DIMENSIONS

Tensile strength of wire: min 650 N/mm²
 Wire diameter (d): 1.60mm
 Flattened wire dimension: (A): 1.35mm
 (B): 1.60mm
 Head height (D): 0.75mm
 Head width (C): 3.10mm
 Strip length (LP): 50 brads
 Standard point: Diamond
 Standard brad lengths (Lh): 32mm – 64mm

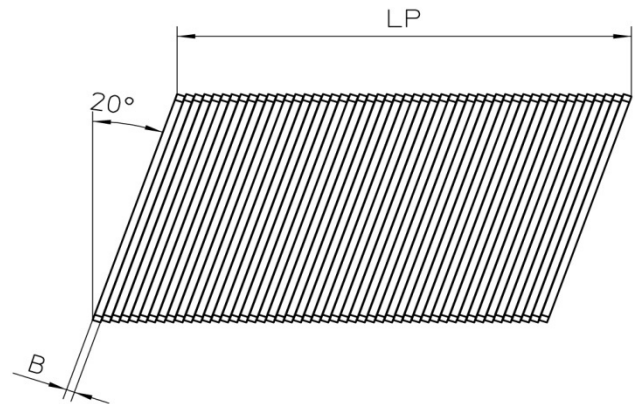
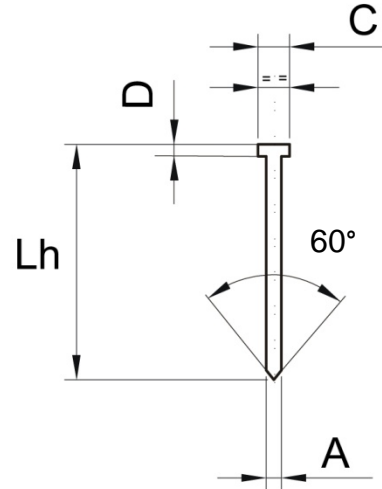

BRAD LENGTHS AVAILABLE*

Finish	Lengths Available <small>*Other lengths on request</small>
Zinc Galv	32mm, 38mm, 45mm, 51mm, 64mm
Stainless Steel A2 AISI 304 / WNr 1.4301	32mm, 38mm, 50mm, 64mm
Stainless Steel A4 AISI 316 / WNr 1.4401	32mm, 38mm, 50mm, 64mm

Paslode is a brand of the ITW Group. ITW reserves the right to change specification without notice. All design using this data should be carried out by a qualified structural engineer, subject to relevant National and European standards or regulations.