

Daikin Altherma mid
temperature split
Technical Data
ELVH-E6V / ELVH-E9W /
ELVX-E6V / ELVX-E9W



TABLE OF CONTENTS

ELVH-E6V / ELVH-E9W / ELVX-E6V / ELVX-E9W

1	Features	4
	ELVH-E9W, ELVH-E6V	4
	ELVX-E9W, ELVX-E6V	5
2	Specifications	6
3	Electrical data	14
4	Combination table	16
5	Capacity tables	17
	Domestic Hot Water performance	17
6	Dimensional drawings	18
7	Centre of gravity	19
8	Piping diagrams	20
9	Wiring diagrams	21
	Notes & Legend	21
	Control Circuit	22
	Power Supply, Back-up Heater	25
10	External connection diagrams	26
11	Installation	27
	Installation Method	27
12	Operation range	28
13	Hydraulic performance	29
	Static Pressure Drop Unit	29

1 Features

1 - 1 ELVH-E9W, ELVH-E6V

Floor standing air to water heat pump for heating and hot water, ideal for low energy houses

1

- › A combined stainless steel domestic hot water tank of 180 or 230L and heat pump for easy installation
- › Energy efficient heating only system based on air to water heat pump technology
- › Quick configuration in 9 steps in a high resolution colour interface wizard
- › Inclusion of all hydraulic components means no third party components are required
- › The unit's sleek design blends in with other household appliances.



Onecta app

1 Features

1 - 2 ELVX-E9W, ELVX-E6V

Floor standing air to water heat pump for heating, cooling and hot water; ideal for low energy houses

- › A combined stainless steel domestic hot water tank of 180 or 230L and heat pump for easy installation
- › For hot water, heating and cooling
- › Quick configuration in 9 steps in a high resolution colour interface wizard
- › Inclusion of all hydraulic components means no third party components are required
- › The unit's sleek design blends in with other household appliances.

1



Onecta app

2 Specifications

2 - 1 Specifications

2

Technical specifications				ELVH12S18E6V		ELVH12S23E6V				
Heater capacity	Step1		kW			2				
	Step2		kW			2 or 4				
Casing	Colour			White + Black						
	Material			Precoated sheet metal						
Dimensions	Unit	Height	mm	1,655		1,855				
		Width	mm			595				
		Depth	mm			634				
	Packed unit	Height	mm	1,820		2,020				
		Width	mm			720				
		Depth	mm			740				
Weight	Unit		kg	120		129				
	Packed unit		kg	139		147				
Packing	Material			Wood / Carton / Metal / PE wrapping foil						
	Weight		kg	19		18				
PED	Category			Category II						
	Most critical part	Name	Ps*V	Bar*l	Plate heat exchanger					
Refrigerant side heat exchanger	Type			Plate heat exchanger						
	Quantity			1						
	Plates	Quantity			66					
Pump	Type			Grundfos UPM4L K 15-75 130 9 DKI						
	Nr of speeds			PWM						
	Power input		W			75				
Water side Heat exchanger	Type			Plate heat exchanger						
	Model			ACH43-66AH-F						
	Quantity			1						
	Plates	Quantity			66					
	Water volume		l			1.58				
	Water flow rate	Min.		l/min			20.0 (1)			
Expansion vessel	Volume		l			10				
	Max. water pressure		bar			3				
	Pre pressure		bar			1				
Water filter	Diameter perforations		mm			0.8				
	Material			Stainless steel / Plastic						
Tank	Name			Stainless steel domestic hot water tank 180 l		Stainless steel domestic hot water tank 230 L				
	Water volume		l	180		230				
Tank	Material			Stainless steel (DIN 1.4521)						
	Maximum water temperature		°C			70.0				
	Maximum water pressure		bar			10				
	Insulation	Material			Polyurethane foam					
		Heat loss		kWh/24h	1.2 (2)		1.4 (2)			
	Standing heat loss	S		W	50		58			
	Storage volume	V		l	181		220			
	Corrosion protection			Pickling						
Energy efficiency class			B							
General	Supplier/ Manufacturer details	Name or trademark			Daikin Europe N.V.					
	Manufacturer details	Name and address			Daikin Europe N.V. - Zandvoordestraat 300, 8400 Oostende, Belgium					
3-way valve	Coefficient of flow (kV)	Space heating		m ³ /h			8			
		Domestic hot water tank		m ³ /h			10			
Water circuit	Piping connections diameter			inch				G 1" (female)		
	Piping material							Cu		
	Internal piping diameter			inch				1"		
	Piping			inch				1"		
	Safety valve			bar				3		
	Manometer							Digital		
	Drain valve / fill valve							Yes		
	Shut off valve							Yes		
	Air purge valve							Yes		
	Total water volume			l			4.5 (3)			
	Minimum water volume in the system for cooling			l			20			
	Minimum water volume in the system for heating			l			20			
	Water circuit - Domestic hot water side	Piping material							Cu	
		Piping connections	Cold water in / Hot water out		inch			G 3/4" FEMALE		
Refrigerant circuit	Gas side diameter			mm				15.9		
	Liquid side diameter			mm				6.35		
Sound power level	Nom.			dBA				44.0 (4)		
Sound pressure level	Nom.			dBA				30.0 (4)		

2 Specifications

2 - 1 Specifications

Technical specifications					ELVH12S18E6V	ELVH12S23E6V
Operation range	Heating	Ambient	Min.	°C	-25 (5)	
			Max.	°C	25 (5)	
		Water side	Min.	°C	15 (5)	
			Max.	°C	65 (5)	
	Indoor installation	Ambient	Min.	°CDB	5	
Operation range	Indoor installation	Ambient	Max.	°CDB	35	
		Cooling	Ambient	Min.	°CDB	10 (5)
	Max.			°CDB	43 (5)	
	Water side		Min.	°C	5 (5)	
			Max.	°C	22 (5)	
	Domestic hot water	Ambient	Min.	°CDB	-25 (5)	
			Max.	°CDB	35 (5)	
		Water side	Min.	°C	25 (5)	
Max.			°C	62 (5)		
Safety devices	Item	01		Thermal cut out		

Electrical specifications					ELVH12S18E6V	ELVH12S23E6V	
Power supply	Name				See note 7		
	Voltage range	Min.	%		-10		
		Max.	%		10		
IP class	IP				X0		
Electric heater	Power supply	Name			6V3		
		Phase			1~ / 3~		
		Voltage		V	230		
	Current	Maximum running current			A	26.0	
		Zmax	List		Ω	0.22	
	Minimum Ssc value				Equipment complying with EN/IEC 61000-3-12		
Wiring connections	Recommended fuses			A	20.000 (6)		
	Communication cable	Quantity			3+GRD		
		Remark				1.5 mm ²	
	Electric meter	Quantity				2	
		Remark				Minimum 0.75 mm ² (SVDC pulse detection)	
	Preferential kWh rate power supply	Quantity				Power: 2	
		Remark				Power 6.3A (Select diameter and type according to national and local regulations)	
	Domestic hot water pump	Quantity				2	
		Remark				Minimum 0.75 mm ² (2A inrush, 1A continuous)	
	For power supply back-up heater	Quantity				Prewired	
		Remark					
	For connection with R6T	Quantity				2	
		Remark				Minimum 0.75 mm ²	
For connection with A3P	Quantity				Depends on thermostat type, cf. installation manual		
	Remark				Voltage: 230V / Max. current: 100mA / Min. 0.75mm ²		
For connection with M2S	Quantity				2		
	Remark				Voltage: 230V / Max. current: 100mA / Min. 0.75mm ²		
For connection with optional FWXV* (demand input and output)	Quantity				4		
	Remark				100 mA, minimum 0.75 mm ²		

(1) Operation area is extended to lower flow rates depending on operation mode - refer to ESP curve. |

(2) Based on a dT of 45 K |

(3) Including piping + PHE + back-up heater; excluding expansion vessel |

(4) Measured with a pressure drop of 10 kPa in the heating system at an operating condition of leaving water 47-55°C in a room with an ambient of 20°C. DB/WB 7°C/6°. |

(5) For more details, see operation range drawing |

(6) 4 pole 20 A curve 400V tripping class C (refer to wiring diagram) |

(7) Above mentioned power supply of the hydrobox is for the backup heater only. The switch box and the pump of the hydrobox are supplied via the outdoor unit. The optional domestic hot water tank has a separate power supply.

Technical specifications				ELVH12S18E9W	ELVH12S23E9W
Heater capacity	Step1		kW	3	
	Step2		kW	max. 6 kW	
Casing	Colour			White + Black	
	Material			Precoated sheet metal	

2 Specifications

2 - 1 Specifications

2

Technical specifications				ELVH12S18E9W		ELVH12S23E9W		
Dimensions	Unit	Height	mm	1,655		1,855		
		Width	mm			595		
		Depth	mm			634		
	Packed unit	Height	mm	1,820		2,020		
		Width	mm			720		
		Depth	mm			740		
Weight	Unit		kg	120		129		
	Packed unit		kg	139		147		
Packing	Material	Wood / Carton / Metal / PE wrapping foil						
	Weight		kg	19		18		
PED	Category	Category II						
	Most critical part	Name		Plate heat exchanger				
		Ps*V	Bar*l	60				
Refrigerant side heat exchanger	Type	Plate heat exchanger						
	Quantity	1						
	Plates	Quantity	66					
Pump	Type	Grundfos UPMAL K 15-75 130 9 DK1						
	Nr of speeds	PWM						
	Power input		W	75				
Water side Heat exchanger	Type	Plate heat exchanger						
	Model	ACH43-66AH-F						
	Quantity	1						
	Plates	Quantity	66					
	Water volume		l	1.58				
	Water flow rate	Min.	l/min	20.0 (1)				
Expansion vessel	Volume		l	10				
	Max. water pressure		bar	3				
	Pre pressure		bar	1				
Water filter	Diameter perforations		mm	0.8				
	Material	Stainless steel / Plastic						
Tank	Name	Stainless steel domestic hot water tank 180 l			Stainless steel domestic hot water tank 230 L			
	Water volume		l	180		230		
Tank	Material	Stainless steel (DIN 1.4521)						
	Maximum water temperature		°C	70.0				
	Maximum water pressure		bar	10				
	Insulation	Material	Polyurethane foam					
		Heat loss		kWh/24h	1.2 (2)		1.4 (2)	
	Standing heat loss	S	W	50		58		
	Storage volume	V	l	181		220		
	Corrosion protection	Pickling						
Energy efficiency class	B							
General	Supplier/ Manufacturer details	Name or trademark		Daikin Europe N.V.				
		Name and address		Daikin Europe N.V. - Zandvoordestraat 300, 8400 Oostende, Belgium				
3-way valve	Coefficient of flow (kV)	Space heating	m ³ /h	8				
		Domestic hot water tank	m ³ /h	10				
Water circuit	Piping connections diameter		inch	G 1" (female)				
	Piping material	Cu						
	Internal piping diameter		inch	1"				
	Piping		inch	1"				
	Safety valve		bar	3				
	Manometer	Digital						
	Drain valve / fill valve	Yes						
	Shut off valve	Yes						
	Air purge valve	Yes						
	Total water volume		l	4.5 (3)				
	Minimum water volume in the system for cooling		l	20				
	Minimum water volume in the system for heating		l	20				
	Water circuit - Domestic hot water side	Piping material	Cu					
Piping connections		Cold water in / Hot water out	inch	G 3/4" FEMALE				
Refrigerant circuit	Gas side diameter		mm	15.9				
	Liquid side diameter		mm	6.35				
Sound power level	Nom.		dBA	44.0 (4)				
Sound pressure level	Nom.		dBA	30.0 (4)				

2 Specifications

2 - 1 Specifications

Technical specifications					ELVH12S18E9W	ELVH12S23E9W
Operation range	Heating	Ambient	Min.	°C	-25 (5)	
			Max.	°C	25 (5)	
	Water side		Min.	°C	15 (5)	
			Max.	°C	65 (5)	
	Indoor installation	Ambient	Min.	°CDB	5	
Operation range	Indoor installation	Ambient	Max.	°CDB	35	
	Cooling	Ambient	Min.	°CDB	10 (5)	
			Max.	°CDB	43 (5)	
		Water side		Min.	°C	5 (5)
	Max.			°C	22 (5)	
	Domestic hot water	Ambient	Min.	°CDB	-25 (5)	
			Max.	°CDB	35 (5)	
		Water side		Min.	°C	25 (5)
	Max.			°C	62 (5)	
Safety devices	Item	01			Thermal cut out	

Electrical specifications					ELVH12S18E9W	ELVH12S23E9W
Power supply	Name				See note 7	
	Voltage range	Min.	%		-10	
		Max.	%		10	
IP class	IP				X0	
Electric heater	Power supply	Name			9W	
		Phase			3~	
		Voltage	V		400	
	Current	Maximum running current	A		13.0	
	Recommended fuses		A		20.000 (6)	
Wiring connections	Communication cable	Quantity			3+GRD	
		Remark			1.5 mm ²	
	Electric meter	Quantity			2	
		Remark			Minimum 0.75 mm ² (SVDC pulse detection)	
	Preferential kWh rate power supply	Quantity			Power: 2	
		Remark			Power 6.3A (Select diameter and type according to national and local regulations)	
	Domestic hot water pump	Quantity			2	
		Remark			Minimum 0.75 mm ² (2A inrush, 1A continuous)	
	For power supply back-up heater	Quantity			Prewired	
	For connection with R6T	Quantity			2	
Remark				Minimum 0.75 mm ²		
For connection with A3P	Quantity			Depends on thermostat type, cf. installation manual		
	Remark			Voltage: 230V / Max. current: 100mA / Min. 0.75mm ²		
For connection with M2S	Quantity			2		
	Remark			Voltage: 230V / Max. current: 100mA / Min. 0.75mm ²		
For connection with optional FWXV* (demand input and output)	Quantity			4		
	Remark			100 mA, minimum 0.75 mm ²		

(1) Operation area is extended to lower flow rates depending on operation mode - refer to ESP curve. |

(2) Based on a dT of 45 K |

(3) Including piping + PHE + back-up heater; excluding expansion vessel |

(4) Measured with a pressure drop of 10 kPa in the heating system at an operating condition of leaving water 47-55°C in a room with an ambient of 20°C. DB/WB 7°C/6°. |

(5) For more details, see operation range drawing |

(6) 4 pole 20 A curve 400V tripping class C (refer to wiring diagram) |

(7) Above mentioned power supply of the hydrobox is for the backup heater only. The switch box and the pump of the hydrobox are supplied via the outdoor unit. The optional domestic hot water tank has a separate power supply.

Technical specifications				ELVX12S18E6V	ELVX12S23E6V
Heater capacity	Step1		kW	2	
	Step2		kW	2 or 4	
Casing	Colour			White + Black	
	Material			Precoated sheet metal	

2 Specifications

2 - 1 Specifications

2

Technical specifications				ELVX12S18E6V		ELVX12S23E6V		
Dimensions	Unit	Height	mm	1,655		1,855		
		Width	mm			595		
		Depth	mm			634		
	Packed unit	Height	mm	1,820		2,020		
		Width	mm			720		
		Depth	mm			740		
Weight	Unit	kg	120		129			
	Packed unit	kg	139		147			
Packing	Material	Wood / Carton / Metal / PE wrapping foil						
	Weight	kg	19		18			
PED	Category	Category II						
	Most critical part	Name	Plate heat exchanger					
		Ps*V	Bar*l	60				
Refrigerant side heat exchanger	Type	Plate heat exchanger						
	Quantity	1						
	Plates	Quantity	66					
Pump	Type	Grundfos UPMAL K 15-75 130 9 DK1						
	Nr of speeds	PWM						
	Power input	W	75					
Water side Heat exchanger	Type	Plate heat exchanger						
	Model	ACH43-66AH-F						
	Quantity	1						
	Plates	Quantity	66					
	Water volume	1.58						
	Water flow rate	Min.	l/min	20.0 (1)				
Expansion vessel	Volume	l	10					
	Max. water pressure	bar	3					
	Pre pressure	bar	1					
Water filter	Diameter perforations	mm	0.8					
	Material	Stainless steel / Plastic						
Tank	Name	Stainless steel domestic hot water tank 180 l		Stainless steel domestic hot water tank 230 L				
	Water volume	l	180		230			
Tank	Material	Stainless steel (DIN 1.4521)						
	Maximum water temperature	°C	70.0					
	Maximum water pressure	bar	10					
	Insulation	Material	Polyurethane foam					
		Heat loss	kWh/24h	1.2 (2)		1.4 (2)		
	Standing heat loss	S	W	50		58		
	Storage volume	V	l	181		220		
	Corrosion protection	Pickling						
Energy efficiency class	B							
General	Supplier/ Manufacturer details	Name or trademark	Daikin Europe N.V.					
		Name and address	Daikin Europe N.V. - Zandvoordestraat 300, 8400 Oostende, Belgium					
3-way valve	Coefficient of flow (kV)	Space heating	m ³ /h	8				
		Domestic hot water tank	m ³ /h	10				
Water circuit	Piping connections diameter	inch	G 1" (female)					
	Piping material	Cu						
	Internal piping diameter	inch	1"					
	Piping	inch	1"					
	Safety valve	bar	3					
	Manometer	Digital						
	Drain valve / fill valve	Yes						
	Shut off valve	Yes						
	Air purge valve	Yes						
	Total water volume	l	4.5 (3)					
	Minimum water volume in the system for cooling	l	20					
	Minimum water volume in the system for heating	l	20					
	Water circuit - Domestic hot water side	Piping material	Cu					
		Piping connections	Cold water in / Hot water out	inch	G 3/4" FEMALE			
Refrigerant circuit	Gas side diameter	mm	15.9					
	Liquid side diameter	mm	6.35					
Sound power level	Nom.	dBA	44.0 (4)					
Sound pressure level	Nom.	dBA	30.0 (4)					

2 Specifications

2 - 1 Specifications

Technical specifications					ELVX12S18E6V	ELVX12S23E6V
Operation range	Heating	Ambient	Min.	°C	-25 (5)	
			Max.	°C	25 (5)	
	Water side	Min.	°C	15 (5)		
		Max.	°C	65 (5)		
Indoor installation	Ambient	Min.	°CDB	5		
Operation range	Indoor installation	Ambient	Max.	°CDB	35	
	Cooling	Ambient	Min.	°CDB	10 (5)	
			Max.	°CDB	43 (5)	
		Water side	Min.	°C	5 (5)	
			Max.	°C	22 (5)	
	Domestic hot water	Ambient	Min.	°CDB	-25 (5)	
			Max.	°CDB	35 (5)	
Water side		Min.	°C	25 (5)		
		Max.	°C	62 (5)		
Safety devices	Item	01		Thermal cut out		

Electrical specifications					ELVX12S18E6V	ELVX12S23E6V	
Power supply	Name				See note 7		
	Voltage range	Min.	%		-10		
		Max.	%		10		
IP class	IP				X0		
Electric heater	Power supply	Name			6V3		
		Phase			1~ / 3~		
		Voltage		V	230		
	Current	Maximum running current			A	26.0	
		Zmax	List		Ω	0.22	
		Minimum Ssc value				Equipment complying with EN/IEC 61000-3-12	
Wiring connections	Recommended fuses			A	20.000 (6)		
	Communication cable	Quantity				3+GRD	
		Remark				1.5 mm ²	
	Electric meter	Quantity				2	
		Remark				Minimum 0.75 mm ² (SVDC pulse detection)	
	Preferential kWh rate power supply	Quantity				Power: 2	
		Remark				Power 6.3A (Select diameter and type according to national and local regulations)	
	Domestic hot water pump	Quantity				2	
		Remark				Minimum 0.75 mm ² (2A inrush, 1A continuous)	
	For power supply back-up heater	Quantity				Prewired	
		Remark					
	For connection with R6T	Quantity				2	
		Remark				Minimum 0.75 mm ²	
	For connection with A3P	Quantity				Depends on thermostat type, cf. installation manual	
Remark					Voltage: 230V / Max. current: 100mA / Min. 0.75mm ²		
For connection with M2S	Quantity				2		
	Remark				Voltage: 230V / Max. current: 100mA / Min. 0.75mm ²		
For connection with optional FWXV* (demand input and output)	Quantity				4		
	Remark				100 mA, minimum 0.75 mm ²		

(1) Operation area is extended to lower flow rates depending on operation mode - refer to ESP curve. |

(2) Based on a dT of 45 K |

(3) Including piping + PHE + back-up heater; excluding expansion vessel |

(4) Measured with a pressure drop of 10 kPa in the heating system at an operating condition of leaving water 47-55°C in a room with an ambient of 20°C. DB/WB 7°C/6°. |

(5) For more details, see operation range drawing |

(6) 4 pole 20 A curve 400V tripping class C (refer to wiring diagram) |

(7) Above mentioned power supply of the hydrobox is for the backup heater only. The switch box and the pump of the hydrobox are supplied via the outdoor unit. The optional domestic hot water tank has a separate power supply.

Technical specifications				ELVX12S18E9W	ELVX12S23E9W
Heater capacity	Step1		kW	3	
	Step2		kW	max. 6 kW	
Casing	Colour			White + Black	
	Material			Precoated sheet metal	

2 Specifications

2 - 1 Specifications

2

Technical specifications				ELVX12S18E9W		ELVX12S23E9W	
Dimensions	Unit	Height	mm	1,655		1,855	
		Width	mm			595	
		Depth	mm			634	
	Packed unit	Height	mm	1,820		2,020	
		Width	mm			720	
		Depth	mm			740	
Weight	Unit	kg	120		129		
	Packed unit	kg	139		147		
Packing	Material		Wood / Carton / Metal / PE wrapping foil				
	Weight	kg	19		18		
PED	Category		Category II				
	Most critical part	Name Ps*V	Bar*l	Plate heat exchanger 60			
	Refrigerant side heat exchanger	Type		Plate heat exchanger			
Pump	Quantity		1				
	Plates	Quantity	66				
	Type		Grundfos UPMAL K 15-75 130 9 DK1 PWM				
Water side Heat exchanger	Nr of speeds		75				
	Power input	W					
	Type		Plate heat exchanger				
Expansion vessel	Model		ACH43-66AH-F				
	Quantity		1				
	Plates	Quantity	66				
	Water volume	l	1.58				
	Water flow rate	Min.	l/min	20.0 (1)			
	Water filter	Volume	l	10			
Max. water pressure		bar	3				
Pre pressure		bar	1				
Tank	Diameter perforations	mm	0.8				
	Material		Stainless steel / Plastic				
Tank	Name		Stainless steel domestic hot water tank 180 l		Stainless steel domestic hot water tank 230 L		
	Water volume	l	180		230		
Tank	Material		Stainless steel (DIN 1.4521)				
	Maximum water temperature	°C	70.0				
	Maximum water pressure	bar	10				
	Insulation	Material		Polyurethane foam			
		Heat loss	kWh/24h	1.2 (2)		1.4 (2)	
	Standing heat loss	S	W	50		58	
	Storage volume	V	l	181		220	
	Corrosion protection		Pickling				
Energy efficiency class		B					
General	Supplier/ Manufacturer details	Name or trademark Name and address	Daikin Europe N.V. Daikin Europe N.V. - Zandvoordestraat 300, 8400 Oostende, Belgium				
	3-way valve	Coefficient of flow (kV)	Space heating Domestic hot water tank	m ³ /h m ³ /h		8 10	
Water circuit	Piping connections diameter	inch	G 1" (female)				
	Piping material		Cu				
	Internal piping diameter	inch	1"				
	Piping	inch	1"				
	Safety valve	bar	3				
	Manometer		Digital				
	Drain valve / fill valve		Yes				
	Shut off valve		Yes				
	Air purge valve		Yes				
	Total water volume	l	4.5 (3)				
	Minimum water volume in the system for cooling	l	20				
	Minimum water volume in the system for heating	l	20				
	Water circuit - Domestic hot water side	Piping material		Cu			
Piping connections		Cold water in / Hot water out Recirculation connection	inch inch	G 3/4" FEMALE G 3/4" FEMALE			
Refrigerant circuit	Gas side diameter	mm	15.9				
	Liquid side diameter	mm	6.35				
Sound power level	Nom.	dBA	44.0 (4)				
Sound pressure level	Nom.	dBA	30.0 (4)				

2 Specifications

2 - 1 Specifications

Technical specifications					ELVX12S18E9W	ELVX12S23E9W	
Operation range	Heating	Ambient	Min.	°C	-25 (5)		
			Max.	°C	25 (5)		
	Water side	Ambient	Min.	°C	15 (5)		
			Max.	°C	65 (5)		
Indoor installation	Ambient	Min.	°CDB	5			
		Max.	°CDB	35			
Operation range	Cooling	Ambient	Min.	°CDB	10 (5)		
			Max.	°CDB	43 (5)		
	Water side	Ambient	Min.	°C	5 (5)		
			Max.	°C	22 (5)		
	Domestic hot water	Ambient	Min.	°CDB	-25 (5)		
			Max.	°CDB	35 (5)		
		Water side	Ambient	Min.	°C	25 (5)	
				Max.	°C	62 (5)	
Safety devices	Item	01			Thermal cut out		

Electrical specifications					ELVX12S18E9W	ELVX12S23E9W
Power supply	Name				See note 7	
	Voltage range	Min.	%		-10	
		Max.	%		10	
IP class	IP				X0	
Electric heater	Power supply	Name			9W	
		Phase			3~	
		Voltage	V		400	
	Current	Maximum running current	A		13.0	
	Recommended fuses		A		20.000 (6)	
Wiring connections	Communication cable	Quantity			3+GRD	
		Remark			1.5 mm ²	
	Electric meter	Quantity			2	
		Remark			Minimum 0.75 mm ² (SVDC pulse detection)	
	Preferential kWh rate power supply	Quantity			Power: 2	
		Remark			Power 6.3A (Select diameter and type according to national and local regulations)	
	Domestic hot water pump	Quantity			2	
		Remark			Minimum 0.75 mm ² (2A inrush, 1A continuous)	
	For power supply back-up heater	Quantity			Prewired	
	For connection with R6T	Quantity			2	
		Remark			Minimum 0.75 mm ²	
	For connection with A3P	Quantity			Depends on thermostat type, cf. installation manual	
Remark				Voltage: 230V / Max. current: 100mA / Min. 0.75mm ²		
For connection with M2S	Quantity			2		
	Remark			Voltage: 230V / Max. current: 100mA / Min. 0.75mm ²		
For connection with optional FWXV* (demand input and output)	Quantity			4		
	Remark			100 mA, minimum 0.75 mm ²		

(1) Operation area is extended to lower flow rates depending on operation mode - refer to ESP curve. |

(2) Based on a dT of 45 K |

(3) Including piping + PHE + back-up heater; excluding expansion vessel |

(4) Measured with a pressure drop of 10 kPa in the heating system at an operating condition of leaving water 47-55°C in a room with an ambient of 20°C. DB/WB 7°C/6°. |

(5) For more details, see operation range drawing |

(6) 4 pole 20 A curve 400V tripping class C (refer to wiring diagram) |

(7) Above mentioned power supply of the hydrobox is for the backup heater only. The switch box and the pump of the hydrobox are supplied via the outdoor unit. The optional domestic hot water tank has a separate power supply.

3 Electrical data

3 - 1 Electrical Data

3

ELBH-E6V
ELBH-E9W
ELBX-E6V
ELBX-E9W
ELSH-E
ELSHB-E
ELSX-E
ELXSB-E
ELVH-E6V
ELVH-E9W
ELVX-E6V
ELVX-E9W
ELVZ-E6V
ELVZ-E9W

*** Electrical meter specification**

- Pulse meter type/voltage-free contact for 5 V DC detection by PCB.
- Possible number of pulses
 - 0.1· pulse/kWh
 - 1· pulse/kWh
 - 10· pulse/kWh
 - 100· pulse/kWh
 - 1000· pulse/kWh
- Pulse duration
 - minimum On time: ·40ms·
 - Minirr
- Measurement type (depending on installation)
 - Single-phase AC meter
 - Three-phase AC meter
 - Balanced loads
 - Three-phase AC meter
 - Unbalanced loads

*** Electrical meter installation guideline**

- It is the responsibility of the installer to cover the complete power consumption with electrical meters (combination of estimation and metering is not allowed).
- Required number of electrical meters

Outdoor unit type		ERRA(08/10/12)EA*								
Indoor unit type		ELS(H/X)(B)12P(30/50)EF			ELB(H/X)12EF*			ELV(H/X/Z)12S(18/23)EJ*		
Backup heater type		EKECBU*	EKECBU*	EKECBU*	6V		9W	6V		9W
Backup heater power		1~	1~	3~	1~	3~	3~	1~	3~	3~
Backup heater		1 / 2 / 3	2 / 4 / 6	3 / 6 / 9	2 / 4 / 6	6 kW	3 / 6 / 9	2 / 4 / 6	6 kW	3 / 6 / 9
Normal kWh rate power supply										
Electrical meter type	1~	1	1	-	1	-	-	1	-	-
	3~ balanced	-	-	-	-	-	-	-	-	-
	3~ unbalanced	-	-	1	-	1	1	-	1	1
Preferential kWh rate power supply										
Electrical meter type	1~	2	2	1	2	1	1	2	1	1
	3~ balanced	-	-	-	-	-	-	-	-	-
	3~ unbalanced	-	-	1	-	1	1	-	1	1

4D142815

3 Electrical data

3 - 1 Electrical Data

ELBH-E6V
 ELBH-E9W
 ELBX-E6V
 ELBX-E9W
 ELVH-E6V
 ELVH-E9W
 ELVX-E6V
 ELVX-E9W
 ELVZ-E6V
 ELVZ-E9W

Electrical specifications of the backup heaters and booster heaters

Type	6V				9W							
	2 - 4	2 - 6	2-4 (in case of emergency: 2)	6	3 - 6	3 - 9	3 - 6 (in case of	2				
Capacity setting	[kW]											
Capacity stage -	2	2	2	2	2	2	2	2				
Capacity stage -1-	2	2	2	2	6	3	3	3				
Capacity stage -2-	4	6	4	6	-	6	9	6				
Minimum time delay between stages	Note -4-				Note -4-							
Power supply (1)	Phase	1~			3~			3~				
	Frequency	50							3~			
Current	Voltage	230 +-10%							400 +-10%			
	Nominal running current	A	17,4	26,1	17,4	26,1	15	8,7	13	8,7	13	
Zmax (backup heater)	(2)	Complex							-			
Minimum Ssc value		(3)							-			
Capacity setting	kW								3			
Capacity stage -									1			
Minimum time delay between stages									Note -5-			
Nominal running current	+EK*V3								13			
Booster heater	+EK*Z2								75			
Zmax	Booster heater	(2)	Complex							-		
Nominal running current	Backup heater +-	Booster heater	A	30,4 (17,4+13)	39,1 (26,1+13)	30,4 (17,4+13)	39,1 (26,1+13)	28 (15 + 13)	21,7 (8,7+13)	26 (13+13)	21,7 (8,7+13)	26 (13+13)
	Backup heater +-	Booster heater	A					22,5 (15 + 7,5)	16,2 (8,7+7,5)	20,5 (13+7,5)	16,2 (8,7+7,5)	20,5 (13+7,5)
Minimum Ssc value	Backup heater +-	Booster heater +- EK*V3	kVA					(3)				
		Booster heater +- EK*Z2	kVA					(3)	-	(3)	-	(3)
Notes	(1)	The above-mentioned power supply of the hydrobox is for the backup heater only.										
	(2)	The optional domestic hot water tank has a separate power supply. In accordance with EN/IEC 61000-3-11, it may be necessary to consult the distribution network operator to ensure that the equipment is connected only to a supply with Zsys ≤ Zmax.										
	(3)	The equipment complies with EN/IEC 61000-3-12.										
	EN/IEC 61000-3-11	European/International Technical Standard setting the limits for voltage changes, voltage fluctuations and flicker in public low-voltage supply systems for equipment with rated current ≤ 75 A.										
EN/IEC 61000-3-12	European/International Technical Standard setting the limits for harmonic currents produced by equipment connected to public low-voltage systems with input current > 16 A and ≤ 75 A per phase.											
Zsys	System impedance											

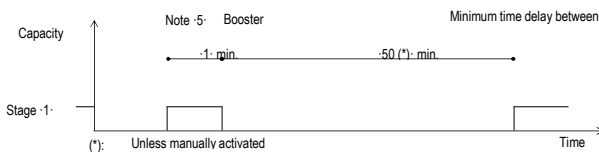
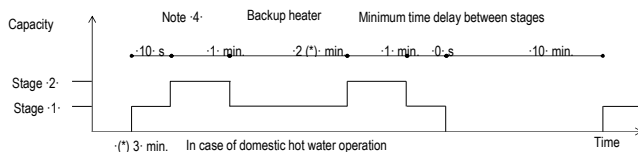

4D121020C

4 Combination table

4 - 1 Combination Table

4

ELVH-E6V
 ELVH-E9W
 ELVX-E6V
 ELVX-E9W
 ELVZ-E6V
 ELVZ-E9W

Factory-mounted equipment for -ELV(H/X/Z)125*EJ*

Description	ELV(H/X/Z)125*EJ*			
Heating only model -ELVH-	18 - 6V (8)	18 - 9W (8)	23 - 6V (8)	23 - 9W (8)
Reversible model -ELVX-	18 - 6V (8)	18 - 9W (8)	23 - 6V (8)	23 - 9W (8)
Integrated Bizone -ELVZ-	18 - 6V (8)	18 - 9W (8)	23 - 6V (8)	23 - 9W (8)
Backup heater -2-4-6kW 1N~230 V-	o	-	o	-
Backup heater -2-4-6kW 3~230 V-	o	-	o	-
Backup heater -3-6-9kW 3N~400 V-	-	o	-	o
Domestic hot water tank -180L-	o	o	-	-
Domestic hot water tank -230L-	-	-	o	o

Outdoor combination table for -ELV(H/X/Z)125(18/23)EJ-

		ERRA08EA(V3/W1)	ERRA10EA(V3/W1)	ERRA12EA(V3/W1)
ELVH125(18/23)EJ*	Heating only indoor unit	o	o	o
ELVX125(18/23)EJ*	Reversible indoor unit	o	o	o
ELVZ125(18/23)EJ*	Integrated Bizone	o	o	o

Kit availability for indoor units

Reference	Description	ETV*125*EJ*			
		18 - 6V	18 - 9W	23 - 6V	23 - 9W
ELVH*	Heating only indoor unit				
ELVX*	Reversible indoor unit				
ELVZ*	Integrated Bizone				
EKRP1HBAA	Digital I/O PCB	*(1) (2)	o	o	o
EKRP1AHTA	Demand PCB	*(3)	o	o	o
BRC1HHDA*	HCI (Human Comfort interface)		o	o	o
EKPCCB4	PC cable	*(4)	o	o	o
KRCS01-1	Remote indoor sensor	*(5)	o	o	o
EKRS01	Remote sensor for outdoor	*(5)	o	o	o
EKCCS-W	Universal centralised user interface		o	o	o
DCOM-LT/O	DCOM gateway		o	o	o
DCOM-LT/MB	DCOM gateway		o	o	o
EKHVCONV4	Conversion kit: heating only to reversible.		o	o	o
FWXV10-15-20ATV3	Heat pump convactor	*(6)	o	o	o
FWXT10-15-20ATV3	Heat pump convactor	*(6)	o	o	o
FWXM10-15-20ATV3	Heat pump convactor	*(6)	o	o	o
EKVKHPC	Heat pump convactor valve kit		o	o	o
EKRTRWA	Wired room thermostat		o	o	o
EKRTRB	Wireless room thermostat		o	o	o
EKRTEIS	External sensor room thermostat	*(7)	o	o	o
EKWUHFHTA1V3	Multi-zoning base unit 230 V	*(9)	o	o	o
EKWCTRD1V3	Digital thermostat 230 V	*(9)	o	o	o
EKWCTRAN1V3	Analogue thermostat 230 V	*(9)	o	o	o
EKWCVATR1V3	Actuator 230 V	*(9)	o	o	o
EKRELSG	Relay for Smart Grid		o	o	o
BRP069A71	WLAN module	*(10)	o	o	o
BRP069A62	LAN module	*(10)	o	o	o
ESAE04A01*	Daikin Residential Controller		o	o	o

Kit availability for outdoor units

Reference	Description	ERRA08EA(V3/W1)	ERRA10EA(V3/W1)	ERRA12EA(V3/W1)
EKMST1	Mounting stand	o	o	o
EKMST2	Mounting stand	o	o	o

Reference	Description	ETV*125*EJ*	
		ELVH*	ELVX*
	Only applicable for :ELVH* & ELVX*- models		
EKMIKPOA	Mixing kit – PCB only	o	o
EKMIKPHA	Mixing kit – PCB with hydraulics	o	o
EKMIKHMA	Hydraulics – mixed pump group	*(11)	o
EKMIKHUA	Hydraulics – unmixed pump group	*(11)	o
EKMIKBVA	Balancing vessel	o	o
EKMIKDIA	Distributor for balancing vessel	*(12)	o

Notes

- (1) PCB that provides additional output connections: -
 - (a) Control external heat source (bivalent operation).
 - (b) Output remote ON/OFF signal space heating/cooling
 - (c) Remote alarm output
- (2) Additional relays to allow bivalent control in combination with an external room thermostat are field-supplied.
- (3) PCB to receive up to -4- digital inputs for power limitation
- (4) Data cable for connection with PC.
- (5) Only 1 remote sensor can be connected: indoor OR outdoor sensor.
- (6) The valve kit is mandatory if a heat pump convactor is installed on a reversible model (not mandatory for heating only models).
- (7) -EKRTETS- can only be used in combination with -EKRTTB-
- (8) The backup heater capacity depends on a user interface setting.
- (9) Multi-zoning wired controls
- (10) The WLAN cartridge is supplied in the accessory bag of the unit and is meant to be plugged into the SD card slot on the MMI-2. In case of bad signal reception, the WLAN cartridge can be removed and replaced by the WLAN or LAN module.
- (11) Only possible in combination with -EKMIKPOA-
- (12) Only possible in combination with -EKMIKBVA- and -EKMIKPHA- or -EKMIKHUA-

Remark

Other combinations than mentioned in this combination table are prohibited.

4D143279

5 Capacity tables

5 - 1 Domestic Hot Water performance

ELSH-E
 ELSHB-E
 ELSX-E
 ELSXB-E
 ELVH-E6V
 ELVH-E9W
 ELVX-E6V
 ELVX-E9W
 ELVZ-E6V
 ELVZ-E9W

Heat-up times

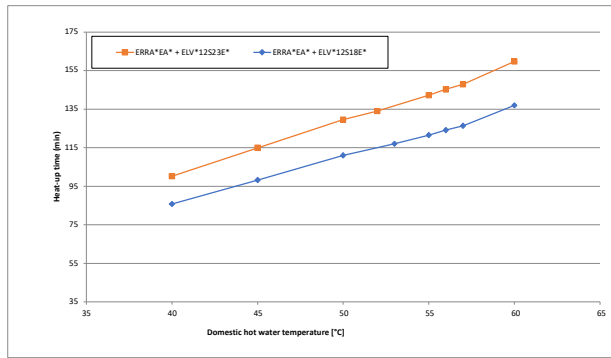

Notes

- Time the indoor unit (heat pump only operation) requires to heat up the domestic hot water tank from 10°C to the indicated temperature. See the operation range for maximum domestic hot water tank temperature during heat pump only operation.

Model name	Heat-up time domestic hot water tank until
ERRA(08/10/12)EA* + ELV*12518E*	~98 min.
ERRA(08/10/12)EA* + ELV*12523E*	~115 min.

Selection guide for the domestic hot water tank volume

Veq 40°C = the amount of water with a temperature of 40°C that can be tapped when the domestic hot water tank is heated to a certain temperature, and the temperature of the cold inlet water is 10°C.

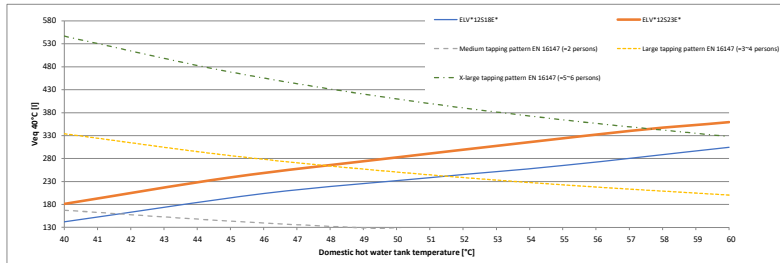

If a higher daily Veq 40°C is required, then additional heat-up cycles are required within 24 hours. See the operation manual for more information.

3D142814

ELSH-E / ELSHB-E / ELSX-E / ELSXB-E / ELVH-E6V / ELVH-E9W / ELVX-E6V / ELVX-E9W / ELVZ-E6V / ELVZ-E9W

Heat-up times

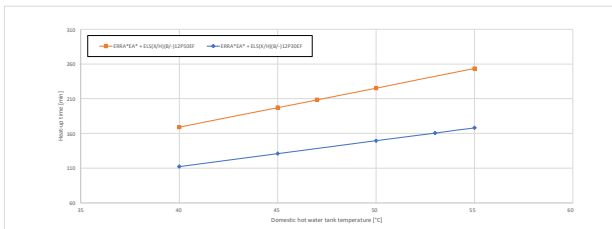

Model name	Heat-up time domestic hot water tank until 45°C
ERRA*EA* + ELSX(N)EB* (12P)SEF	~124 min.
ERRA*EA* + ELSX(N)EB* (12P)SEI	~107 min.

Notes

- Time the indoor unit (heat pump only operation) requires to heat up the domestic hot water tank from 10°C to the indicated temperature. See the operation range for maximum domestic hot water tank temperature during heat pump only operation.

Selection guide for the domestic hot water tank volume

Veq 40°C = the amount of water with a temperature of 40°C that can be tapped when the domestic hot water tank is heated to a certain temperature, and the temperature of the cold inlet water is 10°C.

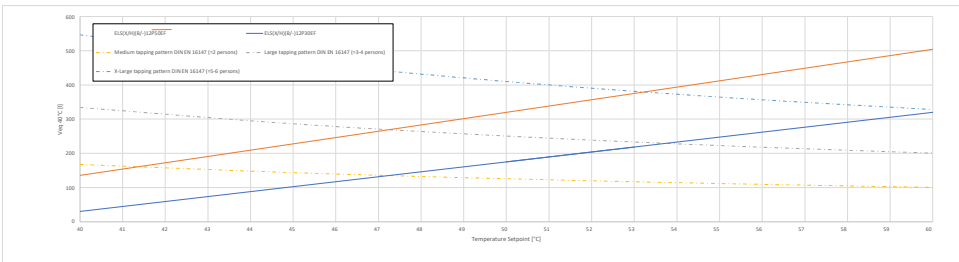

3D142814

6 Dimensional drawings

6 - 1 Dimensional Drawings

6

ELVH-E6V
ELVH-E9W
ELVX-E6V
ELVX-E9W

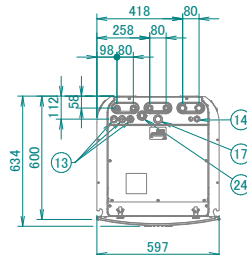
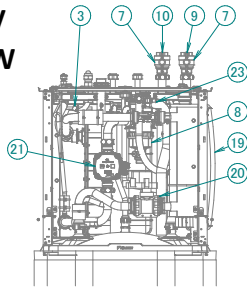

- ① Gas pipe connection ·Ø15.9· flare
- ② Liquid pipe connection ·Ø 6.35· flare
- ③ Space heating water pressure sensor
- ④ Safety valve
- ⑤ Drain valve water circuit
- ⑥ Air purge
- ⑦ Shut-off valve
- ⑧ Magnetic filter / dirt separator
- ⑨ Water in connection ·1" BSP·
- ⑩ Water out connection ·1" BSP·
- ⑪ Domestic hot water: cold water in ·3/4" BSP-F·
- ⑫ Domestic hot water: hot water out ·3/4" BSP-F·
- ⑬ High voltage wiring intake ·Ø24 mm·
- ⑭ Low voltage wiring intake ·Ø15 mm·
- ⑮ Levelling feet
- ⑯ User interface
- ⑰ Recirculation connection ·G3/4"· (female)
- ⑱ Drain outlet (unit + safety valve)

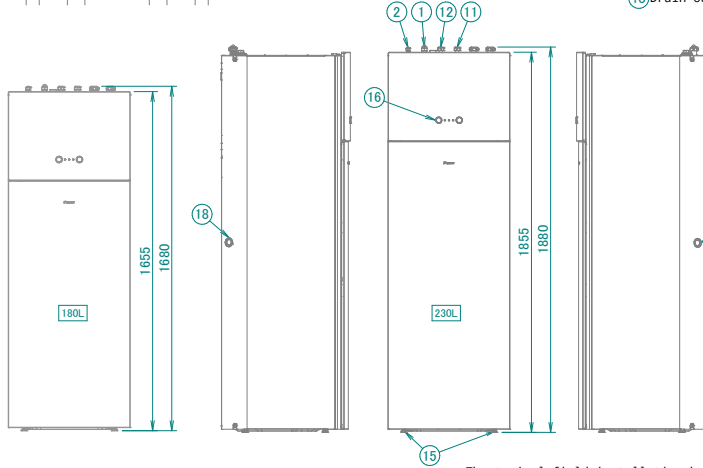

- ⑱ Expansion vessel
- ⑳ 3-way valve
- ㉑ Pump
- ㉒ Backup heater
- ㉓ Flow sensor
- ㉔ Chimney ···

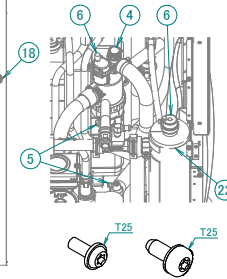

Screws used in this unit:

The typical field installation has to be done according to the applicable legislation.
For examples, refer to the installer reference guide.

3D143264

7 Centre of gravity

7 - 1 Centre of Gravity

- ELVH-E6V**
- ELVH-E9W**
- ELVX-E6V**
- ELVX-E9W**
- ELVZ-E6V**
- ELVZ-E9W**

MODEL	X	Y	Z
ELV (H/X) 12S18EJ*	300	290	940
ELV (H/X) 12S23EJ*	300	295	1070
ELVZ16S18EJ*	290	300	970
ELVZ16S23EJ*	290	305	1090

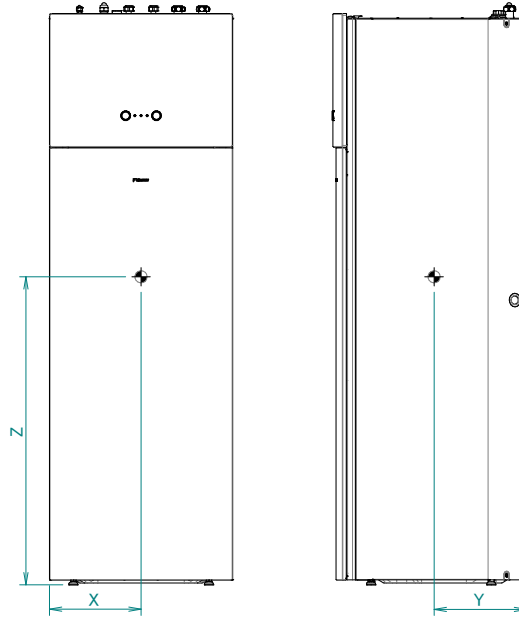

3D146975





7

8 Piping diagrams

8 - 1 Piping Diagrams

8

ELVH-E6V
ELVH-E9W
ELVX-E6V
ELVX-E9W

-  Screw connection
-  Quick coupling
-  Brazed connection
-  Flare connection

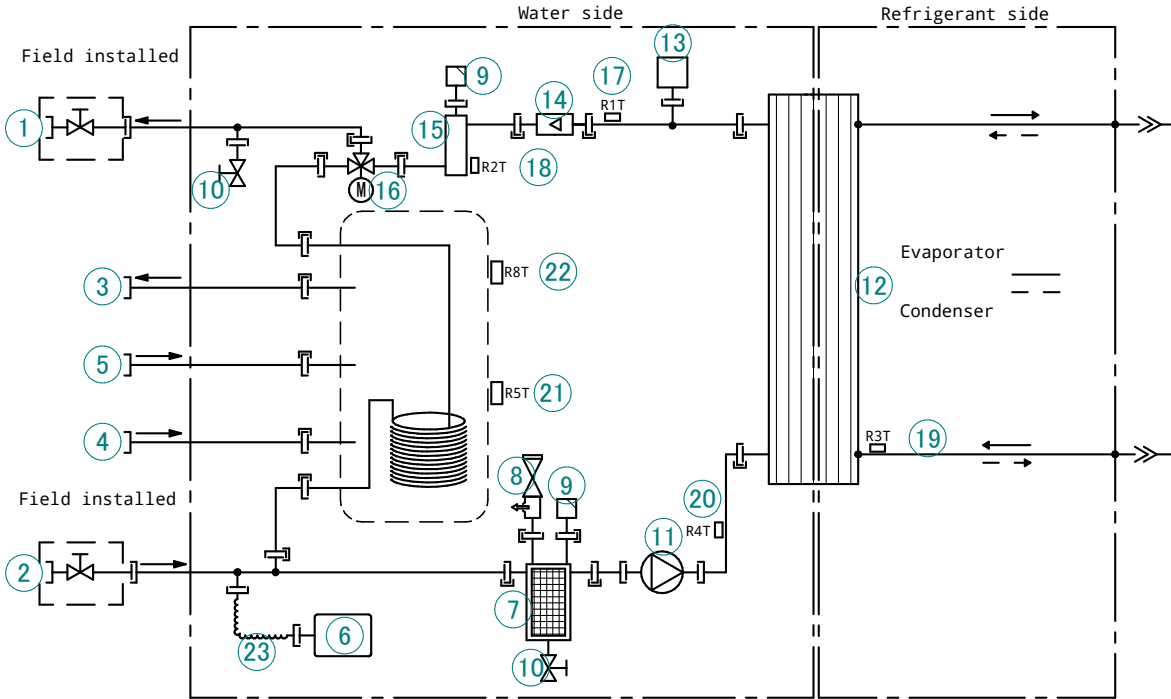

- ① Space heating - water OUT
- ② Space heating - water IN
- ③ Domestic hot water: hot water out
- ④ Domestic hot water: cold water in
- ⑤ Recirculation connection
- ⑥ Expansion vessel
- ⑦ Magnetic filter / dirt separator
- ⑧ Safety valve
- ⑨ Air purge
- ⑩ Drain valve
- ⑪ Pump
- ⑫ Plate heat exchanger
- ⑬ Space heating water pressure sensor
- ⑭ Flow sensor
- ⑮ Backup heater
- ⑯ 3-way valve (space heating/domestic hot water)
- ⑰ R1T - Outlet water heat exchanger thermistor
- ⑱ R2T - Outlet water backup heater thermistor
- ⑲ R3T - Thermistor (heat exchanger, liquid pipe)
- ⑳ R4T - Inlet water thermistor
- ㉑ R5T - Tank thermistor
- ㉒ R8T - Tank thermistor
- ㉓ Flexible pipe

3D143248

9 Wiring diagrams

9 - 1 Notes & Legend

ELVH-E6V / ELVH-E9W / ELVX-E6V / ELVX-E9W

LEGEND

Translation can be found in the installation manual.

* : optional
: field supply

Part n°	Description	P1M	MMI display
A1P	main PCB	PC (A15P)	* power circuit
A2P	On/OFF thermostat (PC=power circuit)	PHC1 (A4P)	* optocoupler input circuit
A3P	heat pump convector	Q1L	# thermal protector backup heater
A4P	digital I/O PCB	Q4L	# safety thermostat
A8P	demand PCB	Q*DI	# earth leakage circuit breaker
A9P	status indicator	R1H (A2P)	* humidity sensor
A11P	MMI main PCB	R1T (A1P)	outlet water heat exchanger thermostat
A13P	LAN adapter	R1T (A2P)	* ambient sensor On/OFF thermostat
A14P	user interface PCB	R1T (A14P)	* ambient sensor user interface
A15P	receiver PCB (wireless On/OFF thermostat)	R2T (A1P)	outlet backup heater thermostat
A20P	WLAN module	R2T (A2P)	* external sensor (floor or ambient) refrigerant liquid side thermostat
A30P	Bizone mixing kit PCB	R3T	inlet water thermostat
B2L	pulse type flow sensor	R5T, R8T	domestic hot water thermostat
B1PW	water pressure sensor	R6T	* external indoor or outdoor ambient thermostat
CN* (A4P)	connector	S1S	# preferential kWh rate PS contact
DS1 (A8P)	dipswitch	S2S	# electrical meter pulse input 1
E1H	backup heater element (1 kW)	S3S	# electrical meter pulse input 2
E2H	backup heater element (2 kW)	S4S	# smartgrid feed-in
E*P (A9P)	indication LED	S6S-S9S	* digital power limitation inputs
F1B	overcurrent fuse backup heater	S10S-S11S	# low voltage smartgrid contact
F1T	thermal fuse backup heater	SS1 (A4P)	* selector switch
F1U, F2U (A4P)	fuse 5 A 250 V for digital I/O PCB	SW1~2 (A11P)	turn buttons
FU1 (A1P)	fuse T 5 A 250 V for PCB	SW3-5 (A11P)	push button
K1A, K2A	high voltage smartgrid relay	TR1	power supply transformer
K1M, K2M	contactor backup heater	X6M	# BUH power supply terminal strip
K5M	safety contactor BUH	X10M	* smartgrid power supply terminal strip
K*R (A1P-A4P)	relay on PCB	X*X, X*A, X*H*, X*Y	connector
M1P	main supply pump	X*M	terminal strip
M2P	domestic hot water pump		
M2S	2 way valve for cooling mode		
M3S	3 way valve for spaceheating /domestic hot water		

NOTES to go through before starting the unit

- X1M : Main terminal
- X2M : Field wiring terminal for AC
- X5M : Field wiring terminal for DC
- X6M : BUH Power supply terminal
- X10M : Smartgrid terminal
- : Earth wiring
- - - : Field supply
- (1) : Several wiring possibilities
- [] : Option
- [] : Not mounted in switch box
- [] : Wiring depending on model
- [] : PCB

Note 1 : Connection point of the power supply for the BUH should be foreseen outside the unit.

POSITION IN SWITCH BOX

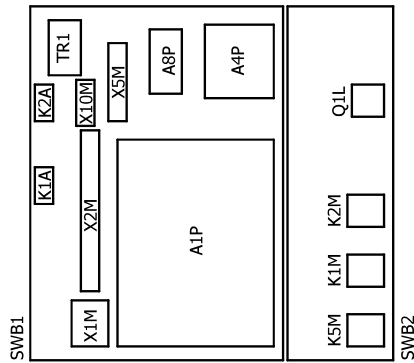

- Backup heater
- power supply
- 6T1 (3~, 230V, 6kW)
- 6V3 (1N~, 230V, 6kW)
- 6WN/9WN (3N~, 400V, 6/9kW)

- User installed options:
- LAN adapter
 - Remote user interface
 - Ext. indoor thermostat
 - Ext. outdoor thermostat
 - Digital I/O PCB
 - Demand PCB
 - Safety thermostat
 - Smartgrid kit
 - WLAN adapter module
 - WLAN cartridge
 - Bizone mixing kit
- Main LWT:
- On/OFF thermostat (wired)
 - On/OFF thermostat (wireless)
 - Ext. thermostat
- Heat pump convector
- Add LWT:
- On/OFF thermostat (wired)
 - On/OFF thermostat (wireless)
 - Ext. thermostat
 - Heat pump convector

4D143254B

9 Wiring diagrams

9 - 2 Control Circuit

9

ELVH-E6V / ELVH-E9W / ELVX-E6V / ELVX-E9W

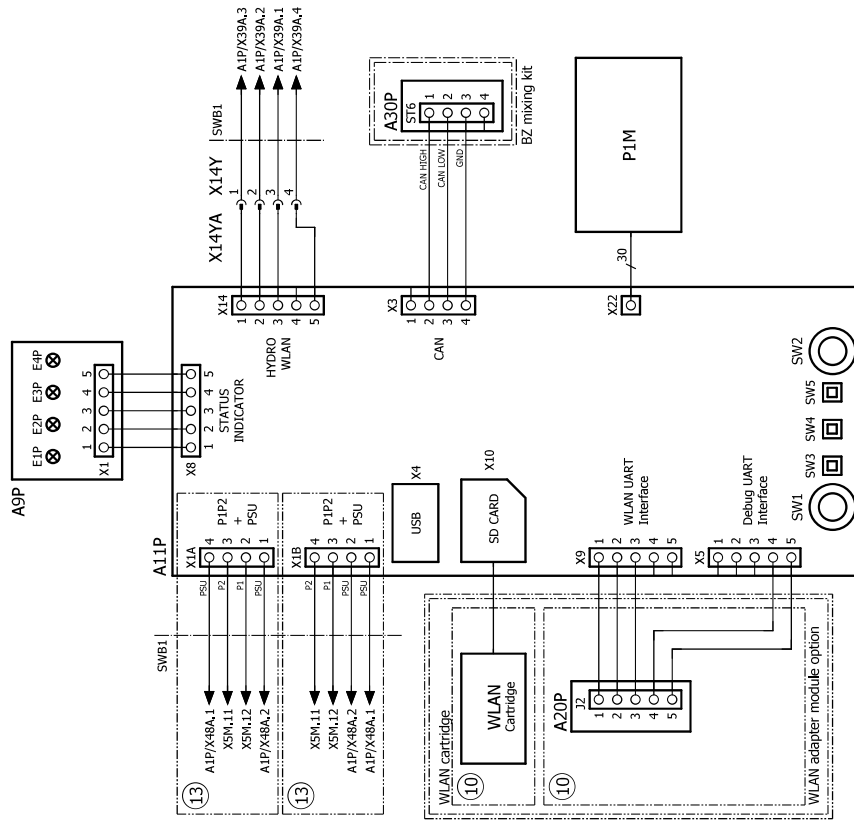

4D143254B

9 Wiring diagrams

9 - 3 Power Supply, Back-up Heater

ELVH-E6V / ELVH-E9W / ELVX-E6V / ELVX-E9W

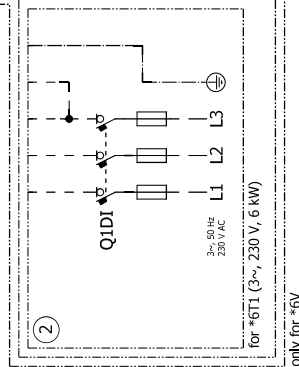
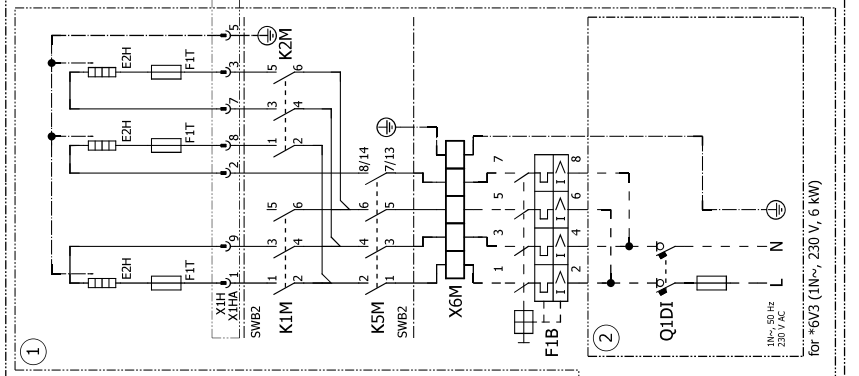
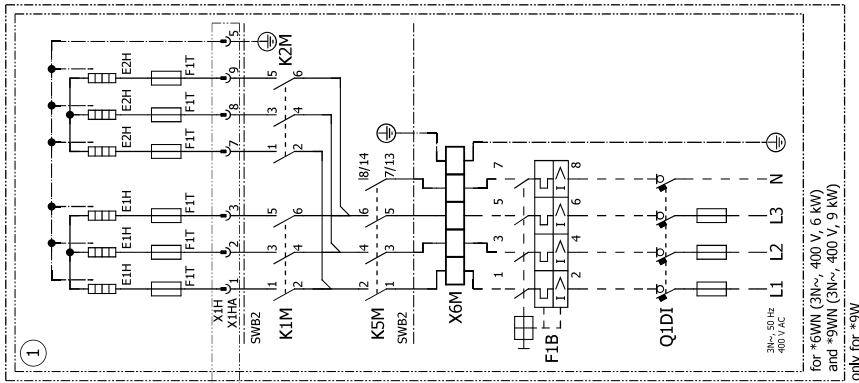
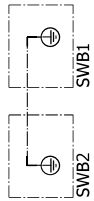

4D143254B

10 External connection diagrams

10 - 1 External Connection Diagrams

10

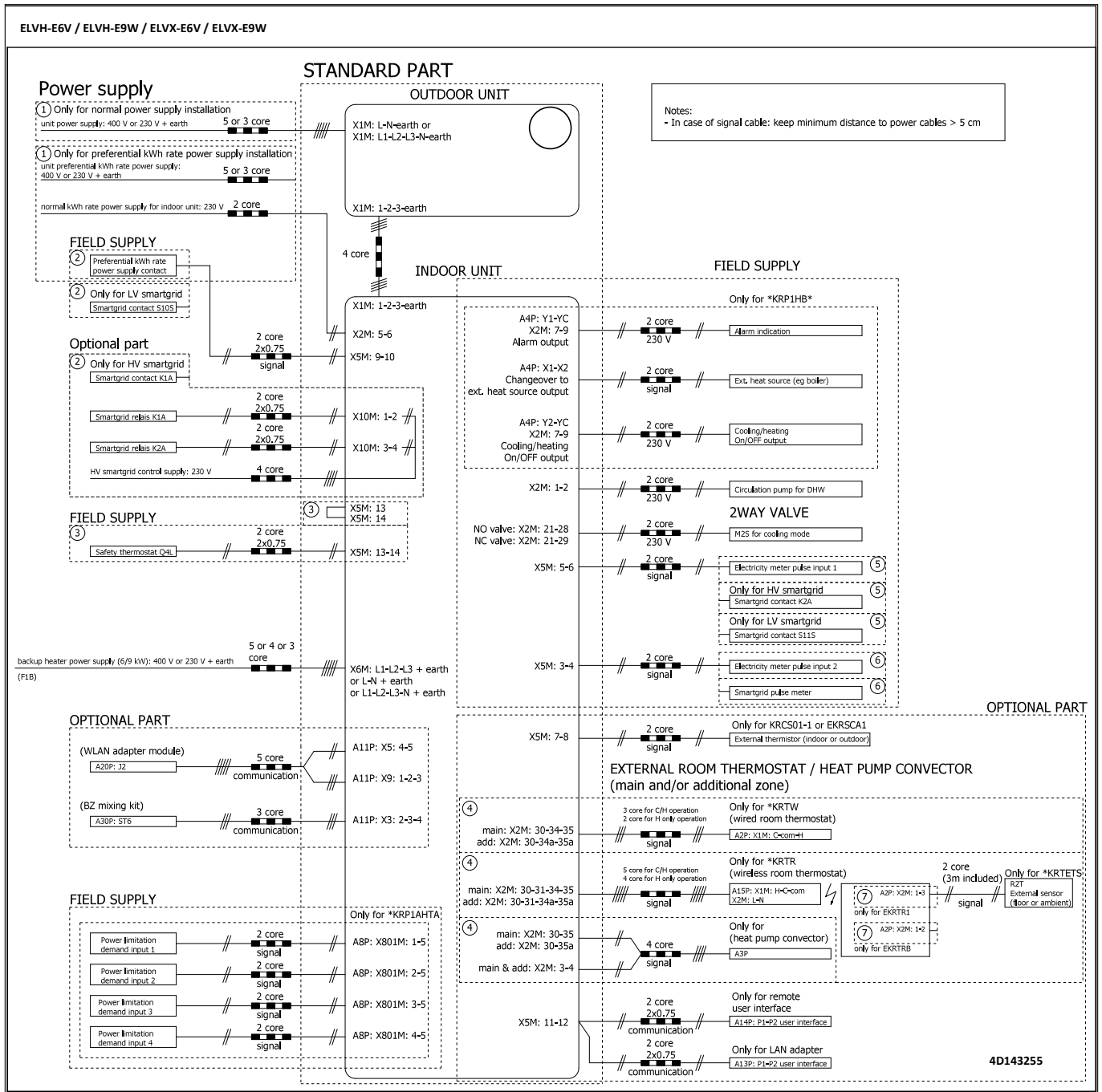

11 Installation

11 - 1 Installation Method

ELVH-E6V
ELVH-E9W
ELVX-E6V
ELVX-E9W
ELVZ-E6V
ELVZ-E9W

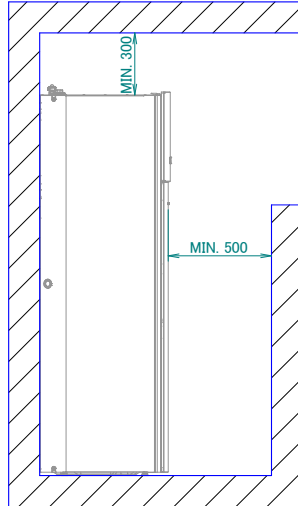
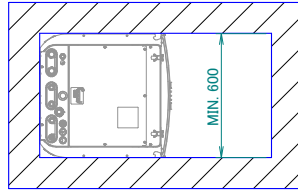

3D136826

12 Operation range

12-1 Operation Range

ELBH-E6V
 ELBH-E9W
 ELBX-E6V
 ELBX-E9W
 ELSH-E
 ELSHB-E
 ELSX-E
 ELSXB-E
 ELVH-E6V
 ELVH-E9W
 ELVX-E6V
 ELVX-E9W
 ELVZ-E6V
 ELVZ-E9W

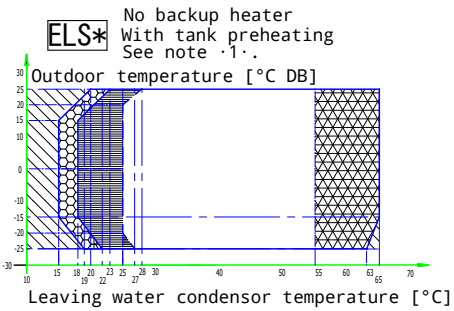
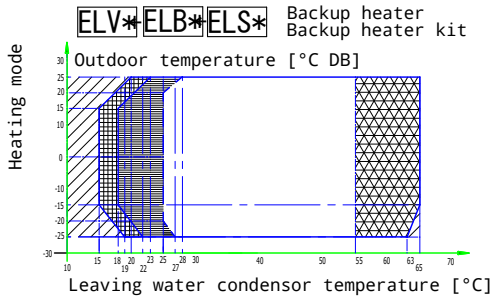
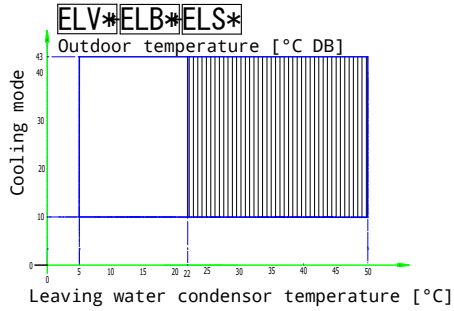

Legend
 [Hatched] Backup heater only operation
 [White] No outdoor unit operation
 [Grid] Heat pump + backup heater operation
 [Dotted] Pull-up area
 [Diagonal lines] Auxiliary boiler only operation
 [White] No outdoor unit operation
 [Cross-hatch] Heat pump + auxiliary boiler operation
 [Dotted] Pull-up area
 [Green] Outdoor unit operation if controller setpoint is regulated to minimal leaving water temperature request.
 See dashed lines

[Cross-hatch] Outdoor unit operation if setpoint > 55°C and ΔT = 10°C (ΔT = outlet temperature - inlet temperature)
 [Grid] Pull-down area

Notes
 1. Tank preheating
 For details, see the installer reference guide.
 2. In restricted power supply mode, the outdoor unit and backup heater can only operate separately.

3D142809

ELBH-E6V
 ELBH-E9W
 ELBX-E6V
 ELBX-E9W
 ELSH-E
 ELSHB-E
 ELSX-E
 ELSXB-E
 ELVH-E6V
 ELVH-E9W
 ELVX-E6V
 ELVX-E9W
 ELVZ-E6V
 ELVZ-E9W

Domestic hot water heating mode

$$ELV* + ELS* + EKHWP* + \begin{matrix} EKHWS*200* \\ EKHWS*250* \\ EKHWS*300* \end{matrix}$$

+ Third-party with identical specifications as EKHWS*200*

$$EKHWS*150* + EKHWS*180*$$

+ Third-party with identical specifications as EKHWS*150*

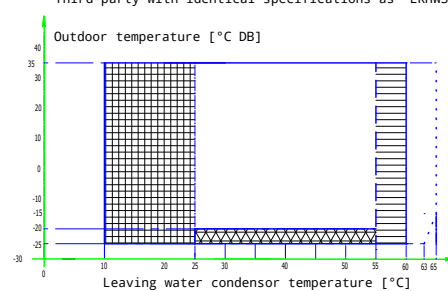
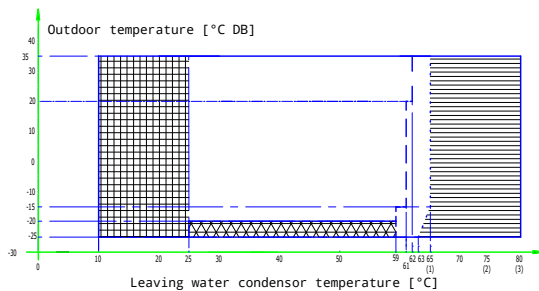

Legend
 - - - Setpoint [°C]
 - - - Domestic hot water
 . . . Leaving water temperature [°C]
 [Grid] Pull-up area
 [Diagonal lines] Booster heater only operation (if a booster heater is part of the system)
 (1) ELV*12* indoor units only
 (2) Combination of EKHWS* and ELB* indoor units / ELS*12* indoor units only
 (3) Combination of EKHWP* and ELB* indoor units
 [Cross-hatch] Operation of the outdoor unit is possible. If the outdoor temperature drops below -20°C, unit will continue operation. But when the unit is OFF and the outdoor temperature is below -20°C, the outdoor unit will not start up. The indoor unit and backup heater will start in these cases.

Notes
 1. In restricted power supply mode (EKHW* only), the outdoor unit, booster heater and backup heater can only operate separately.
 2. Third-party with identical specifications as EKHWS*150*
 Coil surface > 1.05-m² and < 3.7-m²
 Tank thermistor and booster heater above heat pump coil.
 3. Third-party with identical specifications as EKHWS*200*
 Coil surface > 1.8-m² and < 3.7-m²
 Tank thermistor and booster heater above heat pump coil.

3D142810

13 Hydraulic performance

13 - 1 Static Pressure Drop Unit

ELVH-E6V
 ELVH-E9W
 ELVX-E6V
 ELVX-E9W

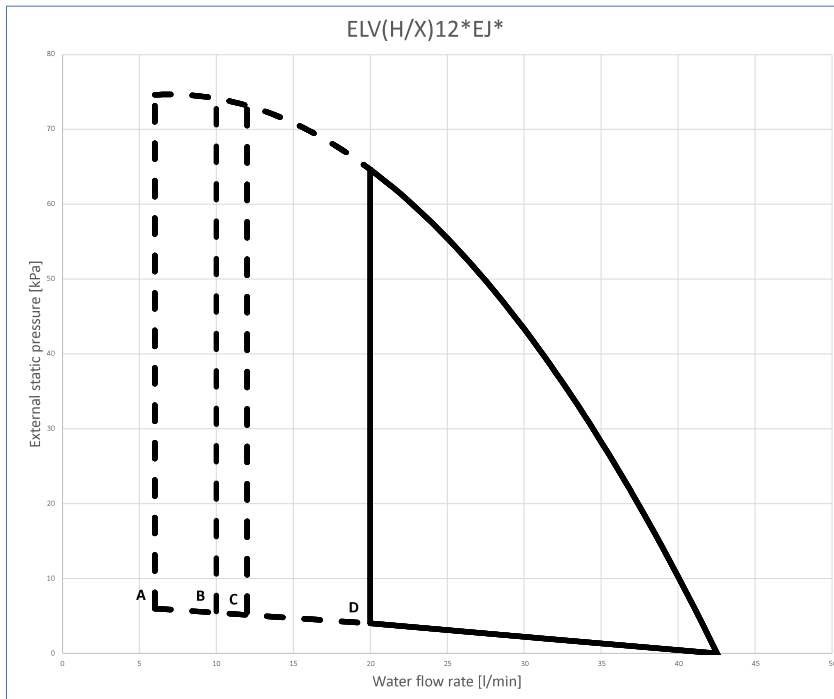

- A= Minimum water flow rate during normal operation
- B= Minimum water flow rate during cooling operation
- C= Minimum water flow rate during backup heater operation
- D= Minimum water flow rate during defrost operation

Notes

1. Selecting a flow outside the operating area can damage the unit or cause the unit to malfunction. See also the minimum and maximum allowed water flow range in the technical specifications.
2. Water quality must be according to EU directive 2020/2184.

3D146897

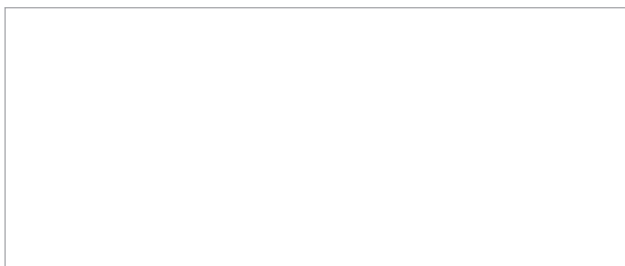

EEEDEN23

05/2023



The present publication is drawn up by way of information only and does not constitute an offer binding upon Daikin Europe N.V. / Daikin Central Europe HandelsGmbH. Daikin Europe N.V. / Daikin Central Europe HandelsGmbH have compiled the content of this publication to the best of their knowledge. No express or implied warranty is given for the completeness, accuracy, reliability or fitness for particular purpose of its content and the products and services presented therein. Specifications are subject to change without prior notice. Daikin Europe N.V. / Daikin Central Europe HandelsGmbH explicitly rejects any liability for any direct or indirect damage, in the broadest sense, arising from or related to the use and/or interpretation of this publication. All content is copyrighted by Daikin Europe N.V.