



INSTALLATION MANUAL

Daikin Altherma Hydraulic accessories

EK2VK0
EK3VK1

EK2VK0 - EK3VK1

- ⚠ To avoid penalising the performance of the system the water inlet and outlet must be as indicated in the various figures.
- ⚠ For a rapid and correct assembly of the components follow carefully the sequences described in the various sections.

⚠ This instruction is an integral part of the booklet of the appliance on which the kit is installed. Please consult this booklet for general warnings and fundamental safety rules.

List of hydraulic accessories

- 2-way valve unit with thermo-electric head kit EK2VK0 for FWX(V/M)- series.
- 3-way deviator valve unit with thermo-electric head deviator valve kit EK3VK1 for FWX(V/M)- series.

Pipeline diameter

The minimum internal diameter that must be respected for the pipelines of the hydraulic connections varies according

to the model:

	U.M.	FWX(V/M)10AATV3	FWX(V/M)15AATV3	FWX(V/M)20AATV3
Pipeline diameter	mm	14	16	18

Access to the body machine

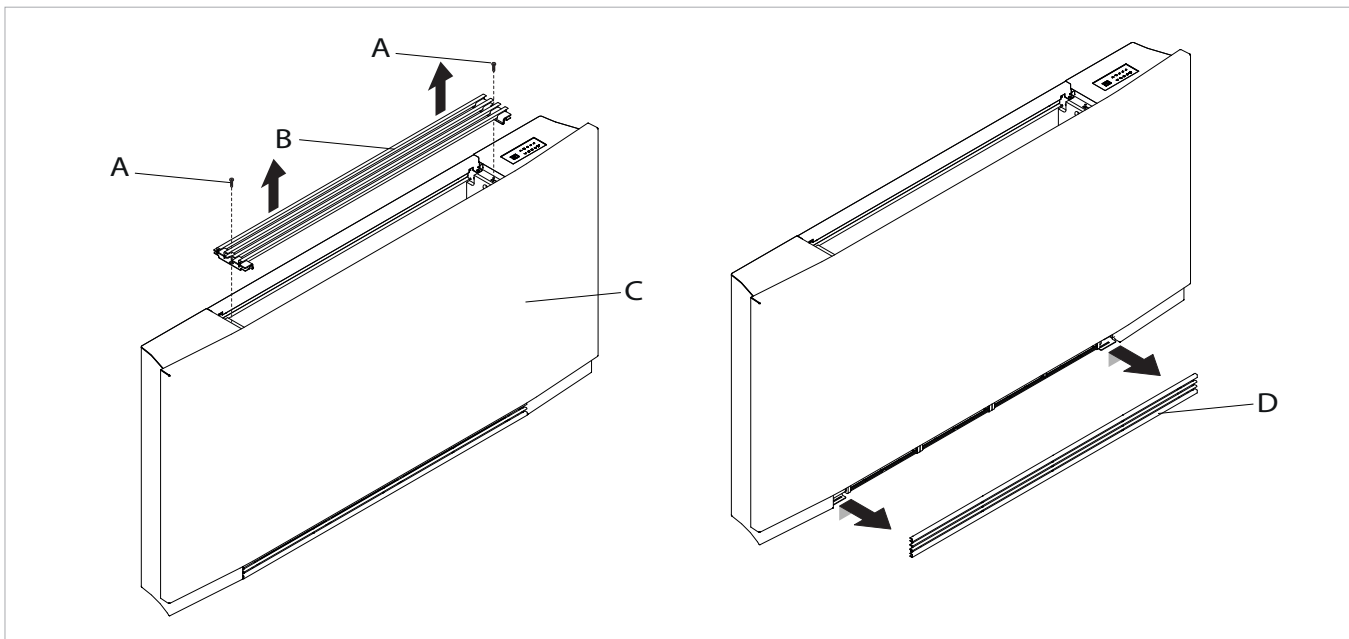
To access the inside of the machine, follow the procedures below.

- Remove the upper grill:- loosen the fixing screws
- loosen the fixing screws of the upper grill
 - remove the grill

- Remove the front grill:
- extract the grill until it is completely out of the seat
 - tilt the grill
 - slide outwards

A	Fixing screws
B	Upper grill

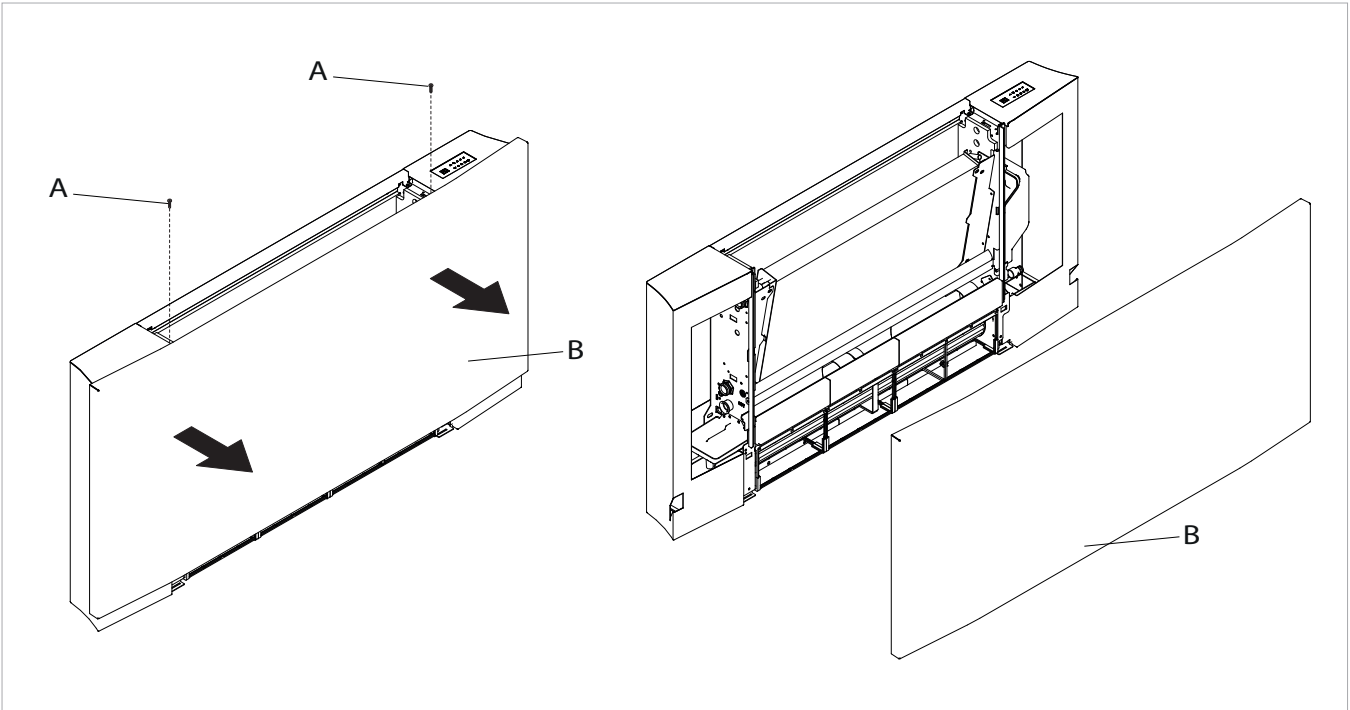
C	Front panel
D	Front grill



Remove the frontal panel:
 - loosen the fixing screws
 - remove the panel

A Fixing screws

B Front panel



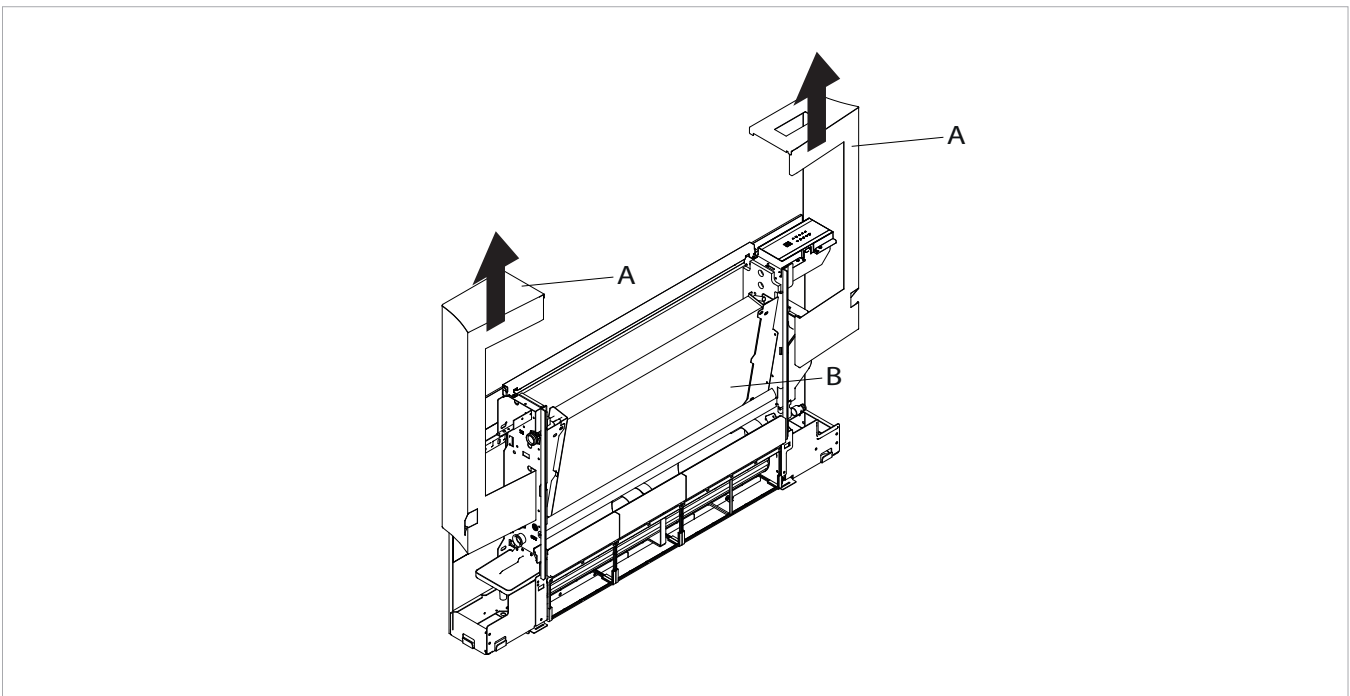
EN

Remove side

To remove the side:
 - remove the sides upwards

A Side

B Machine body



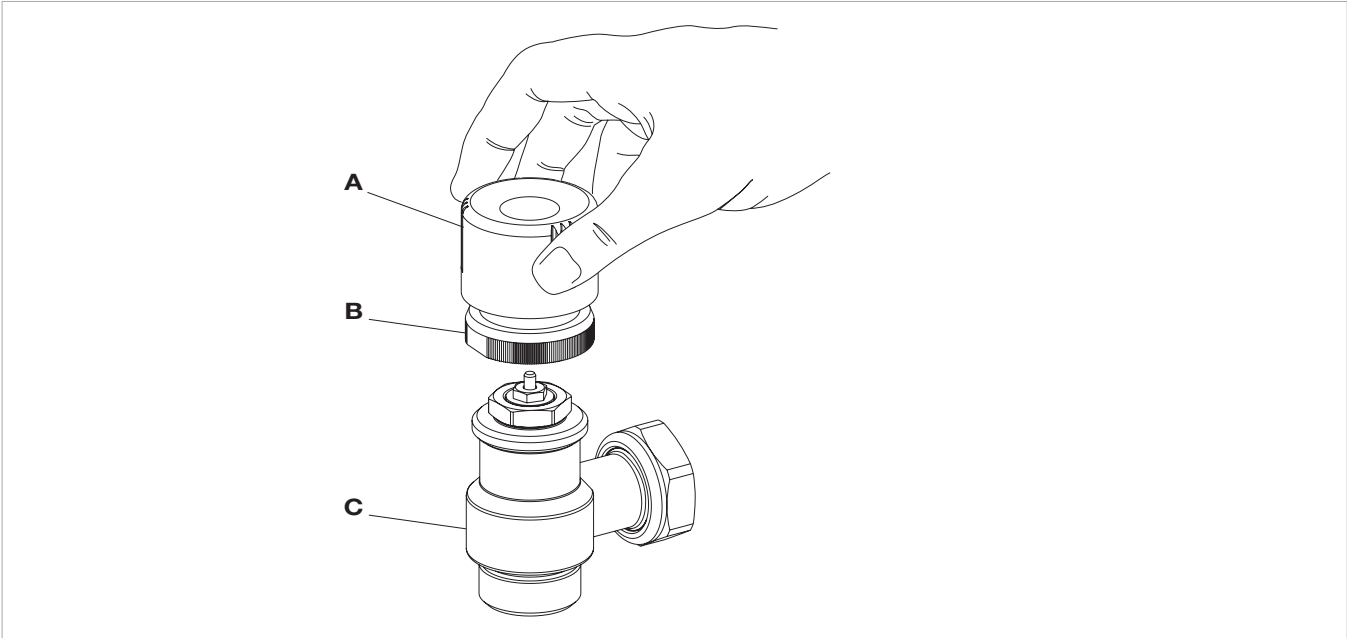
Mounting manual valve

Turn the upper part of the handwheel, keeping the lower locknut blocked, moving it to a completely open position, then tighten until it is fixed to the valve body. At this point,

the handwheel performs the adjustment.

A	upper part of the handwheel
B	lower locknut

C	valve body
----------	------------



Mounting the thermostatic head

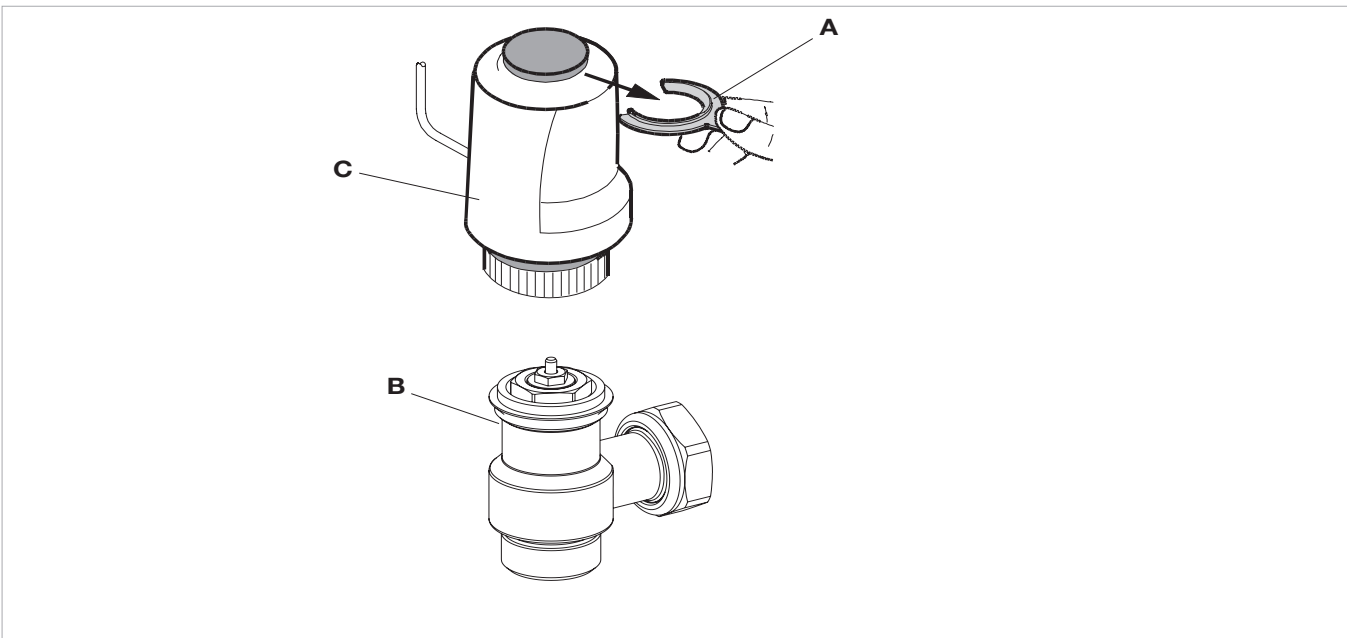
Tighten the plastic disc to the valve body. Attach the head to the valve body.

To facilitate the system mounting, filling and venting operations, even without electric power, the thermostatic head is supplied with a tool that keep it open.

⚠ Remove the tool from the thermostatic head before starting the system.

A	plastic tool
B	valve body

C	thermostatic head
----------	-------------------



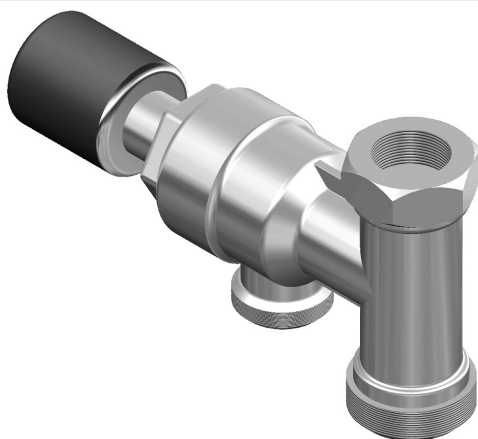
By pass

The by-pass is an overpressure valve that keeps the system balanced when the 2-way supply valve in the cooler-convactor/cooler radiator is closed. Inside, there is a plug which, under normal conditions, remains closed. If, due to the closure of the 2-way valve, it is subjected to

a stress that is more than that of the calibration value, it opens so that the water can circulate through the by-pass circuit.

The valve can be set from 0.3 bar to 0.5 bar, depending on the model:

	U.M.	FWX(V/M)10AATV3	FWX(V/M)15AATV3	FWX(V/M)20AATV3
set the calibration to	bar	0,3	0,4	0,5



EN

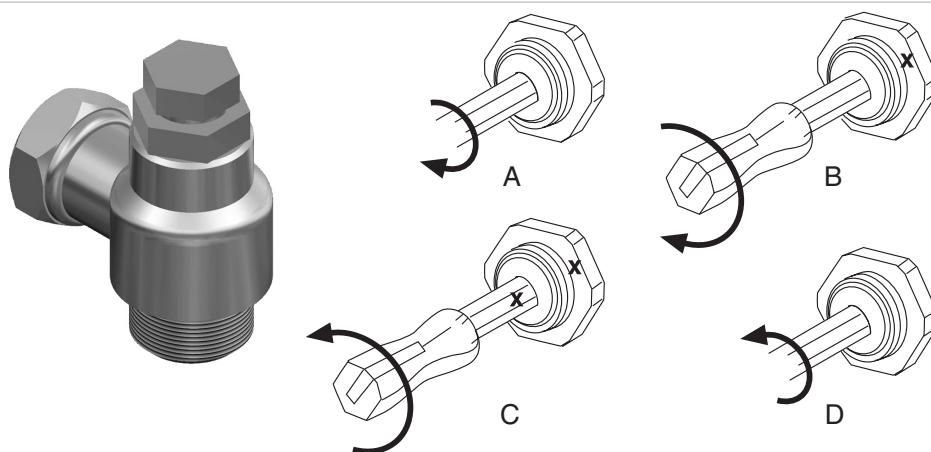
Lockshield adjustment

The lockshields supplied with the hydraulic kits provide an adjustment that balances the system load losses. To ensure a correct adjustment and balancing of the circuit, follow the procedure indicated below:

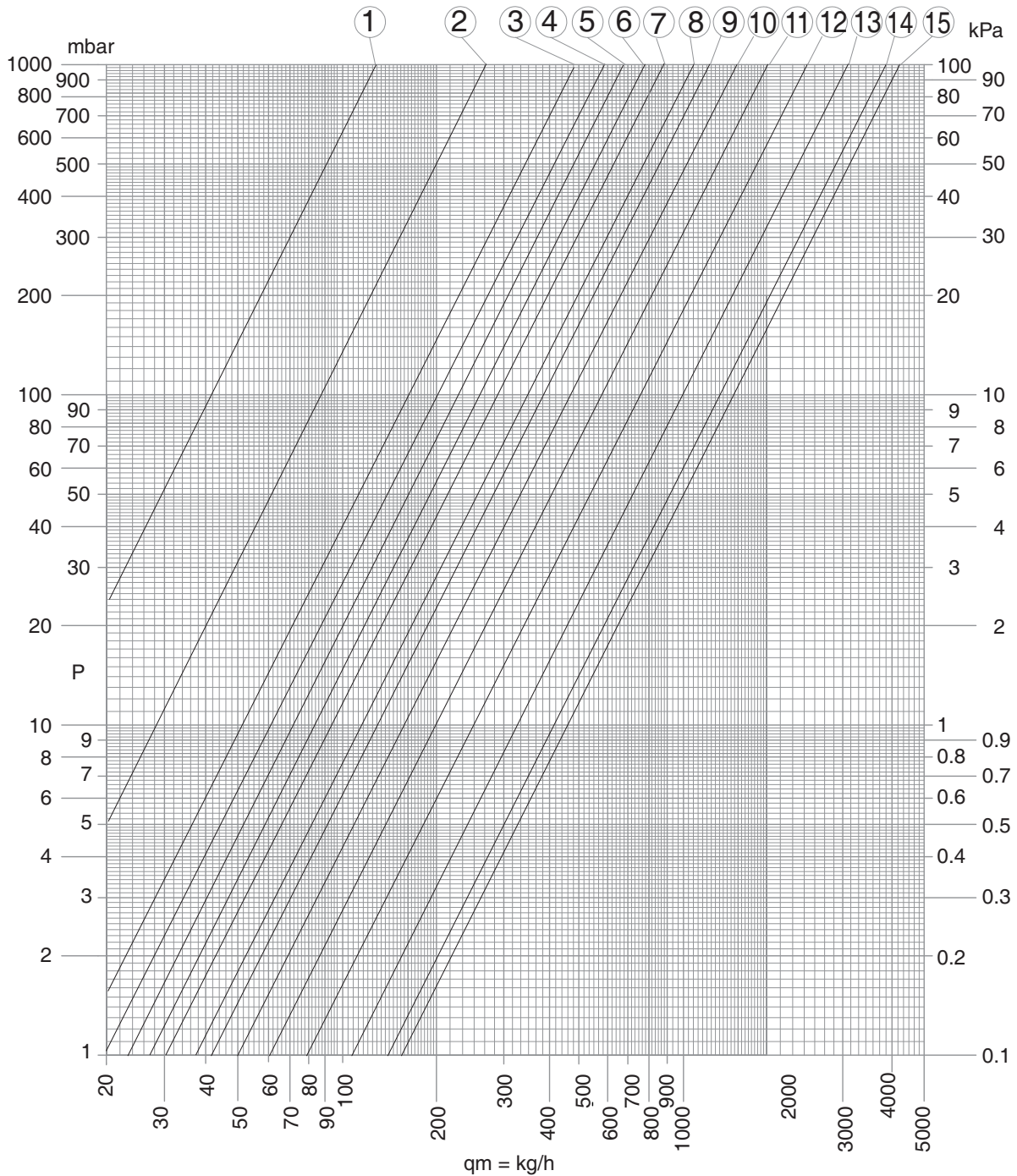
- With a screwdriver, loosen and remove the slotted grub screw inside the hexagonal head.
- Close the adjustment screw using a 5 mm Allen key (A)
- Re-tighten the slotted grub screw then mark the

- reference point for the adjustment with an "x" (B).
- Align the screwdriver with the "x", then open with a number of turns (C) according to diagram $\Delta p-Q$ shown in the next page.

⚠ The number of turns refers to the micrometric screw
 Then fully open the screw (D). Now the pre-adjustment has been set and will not change if there are repeated openings or closings with the Allen key.



Load losses based on the adjustment of the lockshield present in all kits.

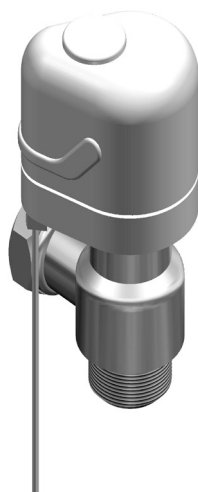


POS.	1	2	3	4	5	6	7	8	10	11	12	13	14	15
ADJ	1 ^{2/4}	2	2 ^{1/4}	2 ^{1/2}	2 ^{3/4}	3	3 ^{1/4}	3 ^{2/4}	4	4 ^{1/2}	5	6	8	T.A.
Kv	0.13	0.28	0.49	0.62	0.70	0.82	0.95	1.33	1.57	1.95	2.47	3.34	4.18	4.52

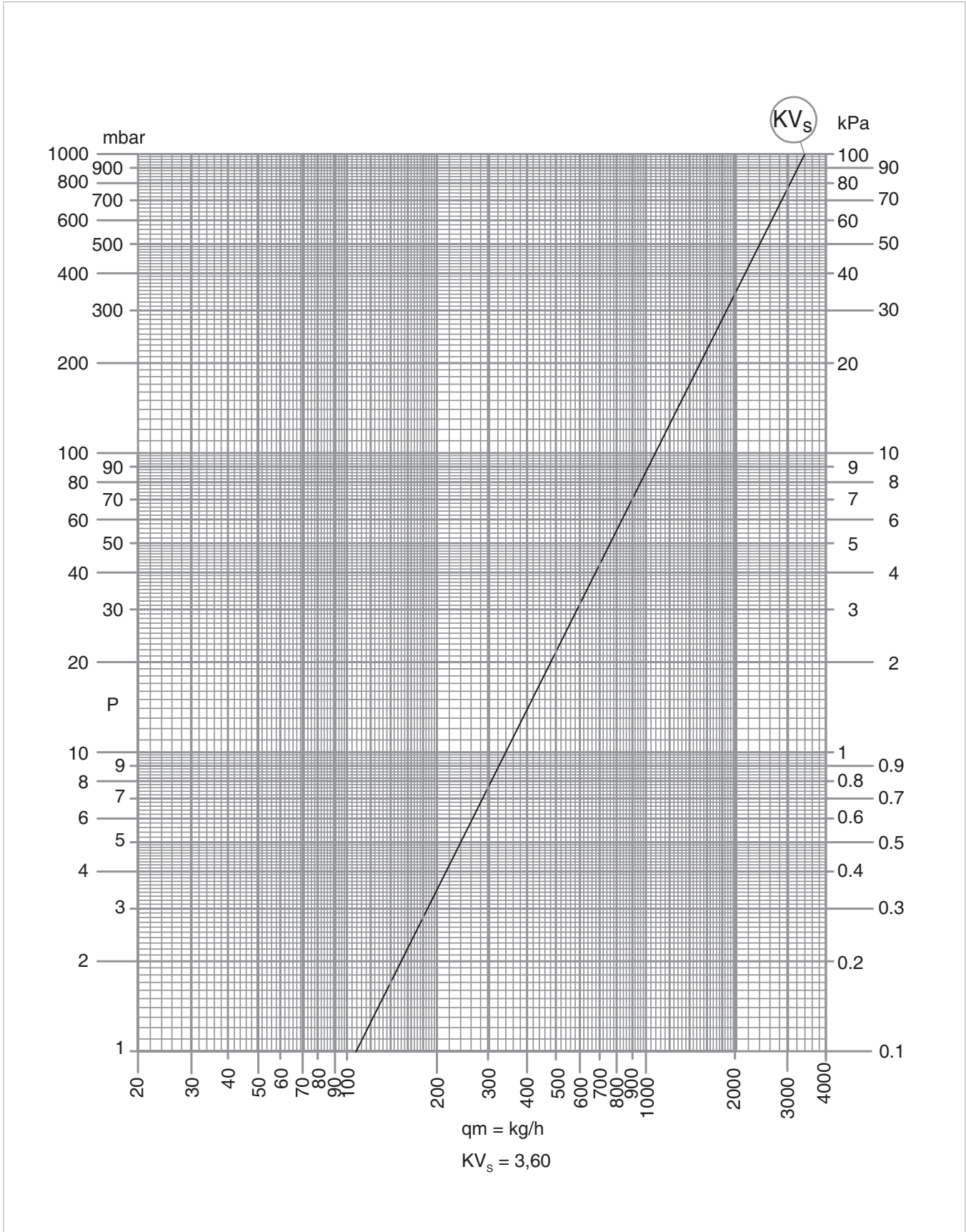
2-Way valve with thermo-electric head kit (EK2VK0)

Consists of an automatic valve with thermo-electric head and a lockshield, fitted with micrometric adjustment, capable of balancing the system load losses.

The kit contains the insulation to be mounted on the valve and on the lockshield.



Load losses in completely open position of 2-way valve present in kits EK2VK0.



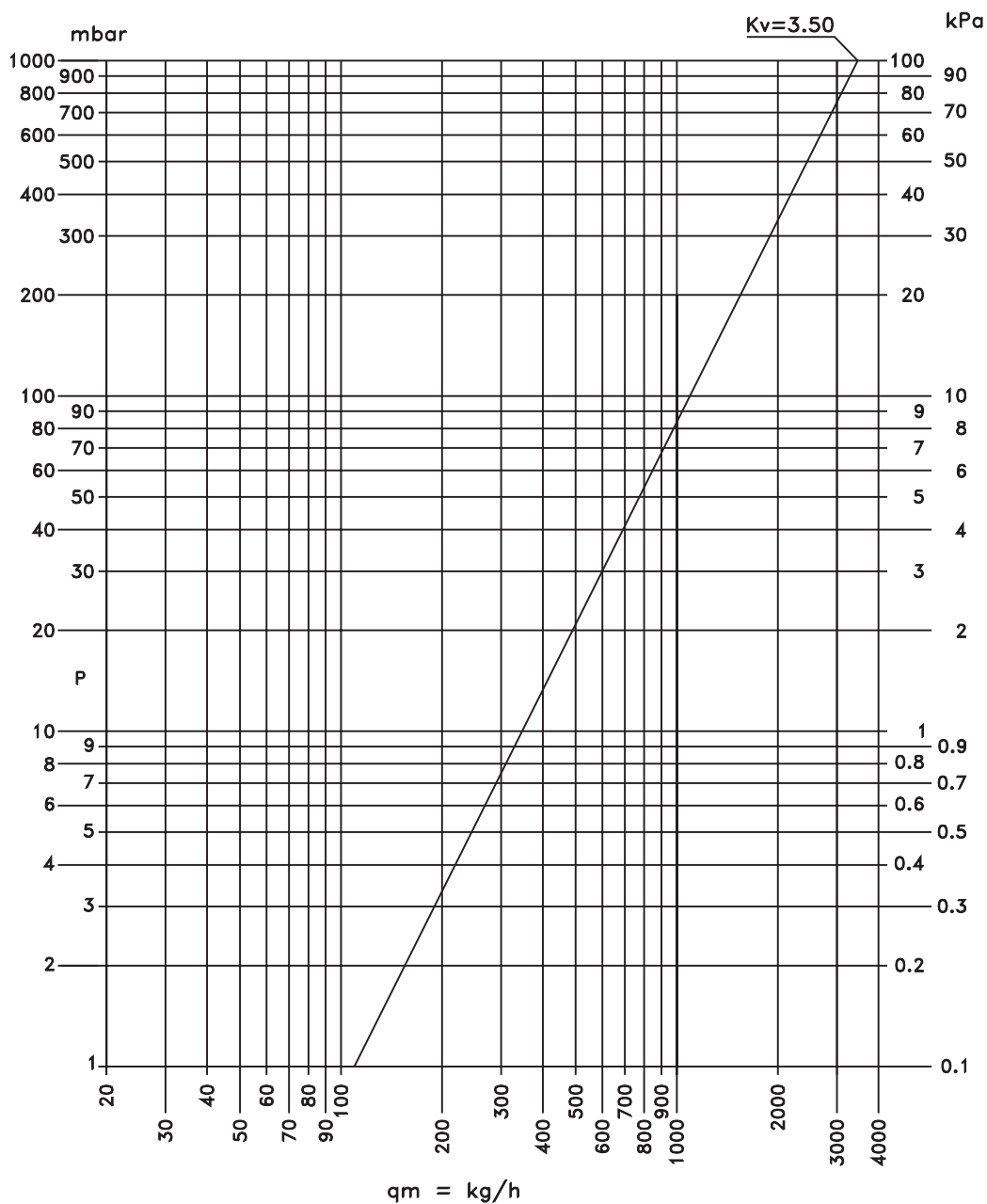
3-Way valve with thermo-electric head deviator valve kit (EK3VK1)

Consists of a 3-way deviator valve with thermo-electric head and a lockshield, fitted with micrometric adjustment, capable of balancing the system load losses).

The kit contains the insulation to be mounted on the valve and on the lockshield.

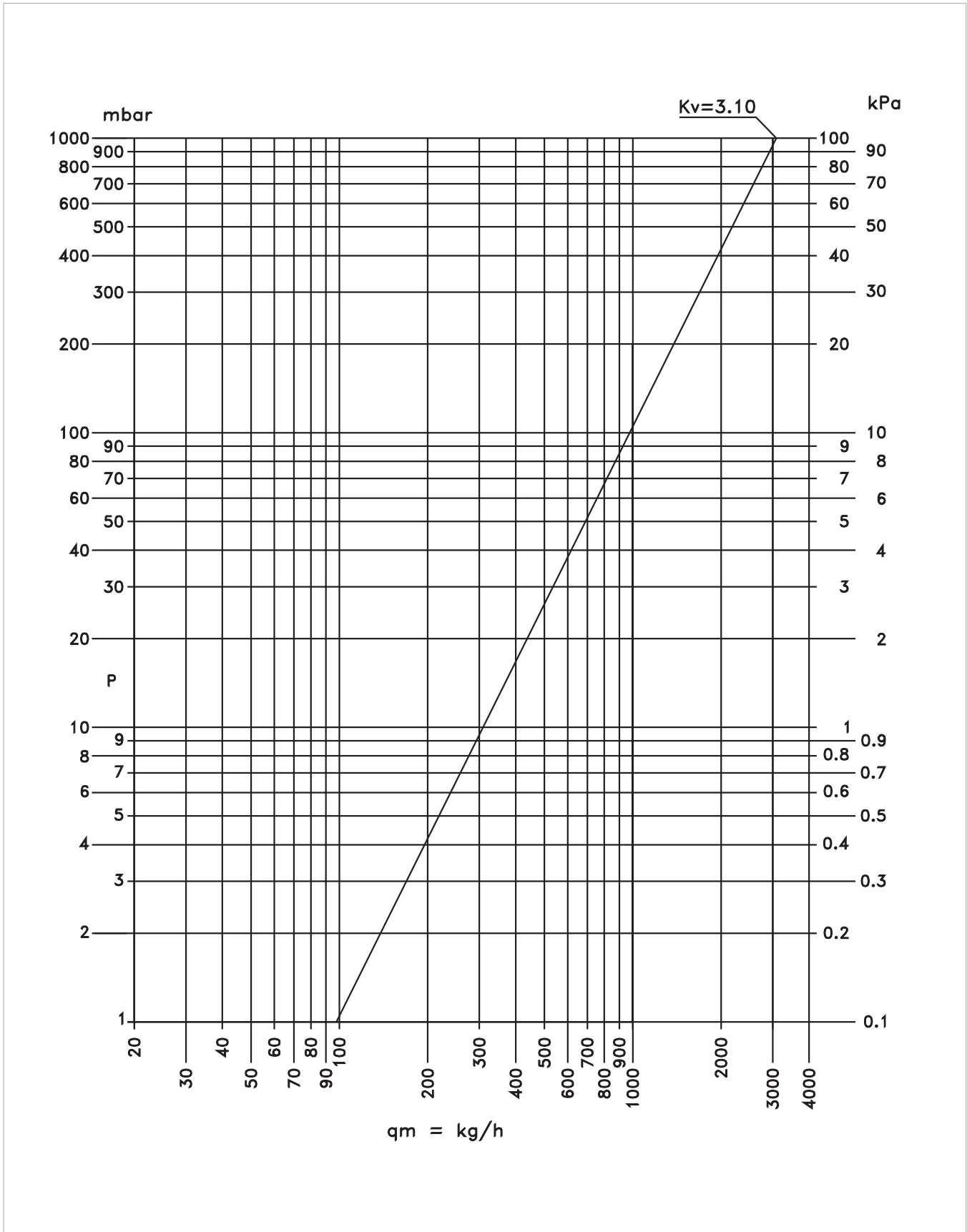


Diagram of load losses of deviator valve, present in kit EK3VK1 in completely open position.



EN

Diagram of load losses of deviator valve, present in kit EK3VK1, in completely closed position.



Connections

The choice and sizing of the hydraulic lines must be made by an expert who must operate according to the rules of good technique and the laws in force.

To make the connections:

- position the hydraulic lines
- tighten the connections using the “spanner and counter spanner” method
- check for any leaks of liquid
- coat the connections with insulating material

The hydraulic lines and joints must be thermally insulated.

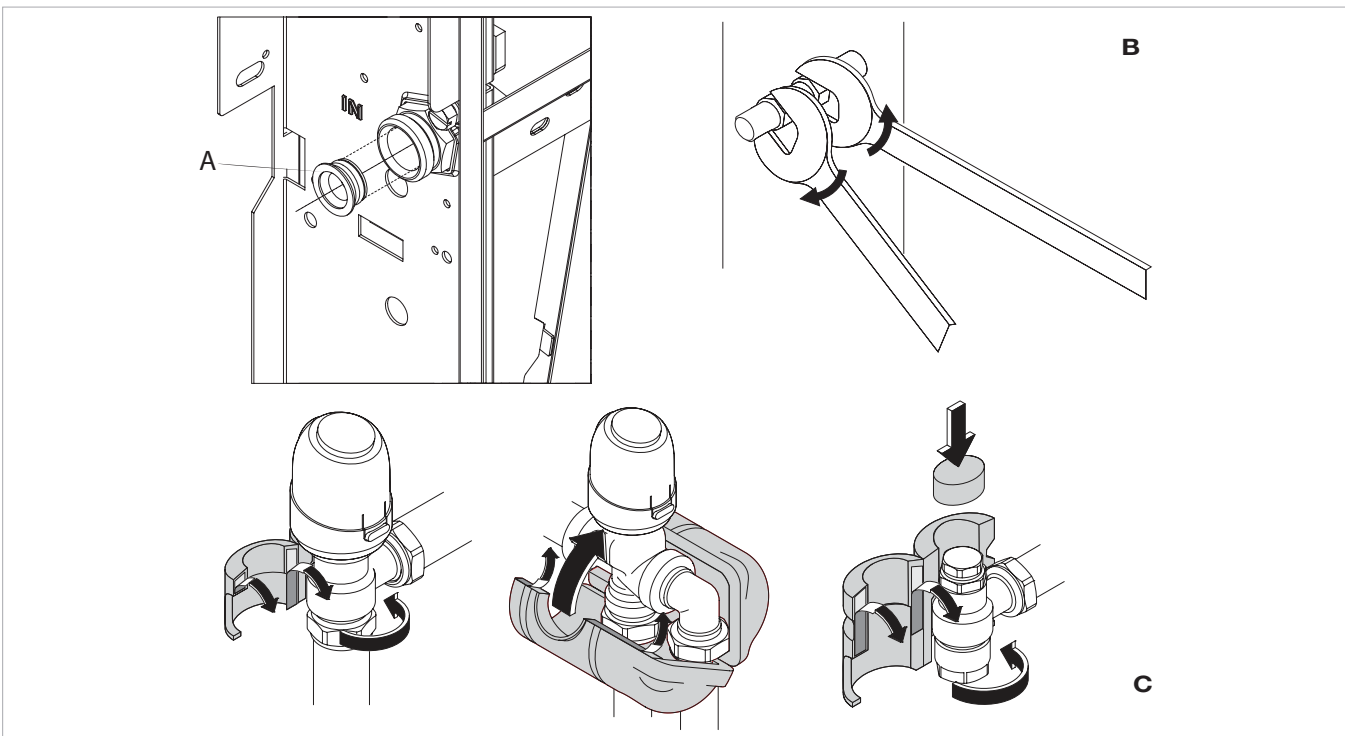
Avoid partially insulating the pipes.

Do not over-tighten to avoid damaging the insulation.

Use hemp and green paste to seal the threaded connections; the use of Teflon is advised when there is anti-freeze in the hydraulic circuit.

A	Eurokonus adapter
B	spanner and counter spanner

C	coat the connections with insulating material
----------	---



EN

FWX(V/M)-SERIES with 2-way valve with thermo-electric head (EK2VK0)

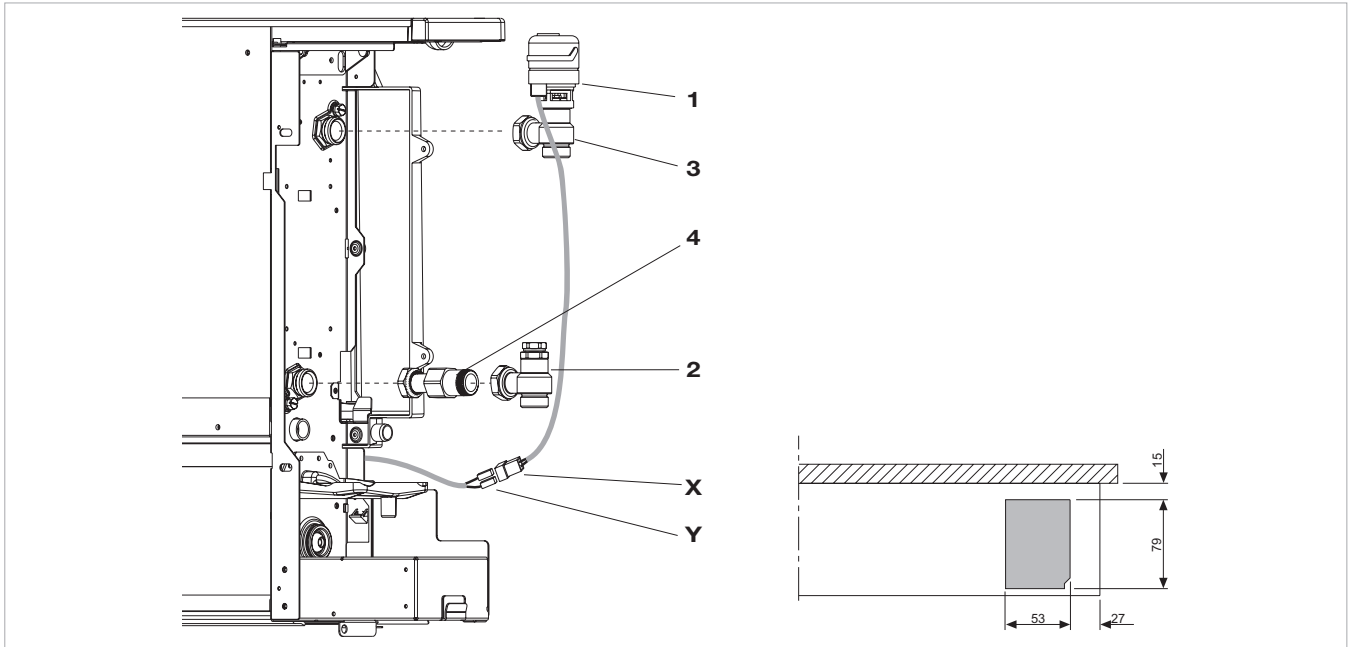
Consists of an automatic valve with thermo-electric head and a lockshield, fitted with micrometric adjustment, capable of balancing the system load losses. The kit contains the insulation to be mounted on the valve and on the lockshield.

- Remove the side panel as indicated in paragraph Side opening.
- Assemble the components as indicated in figure
- Apply the supplied insulation.

⚠ When the hydraulic components have been mounted, connect the thermo-electric head connectors with the wiring connectors on the machine.

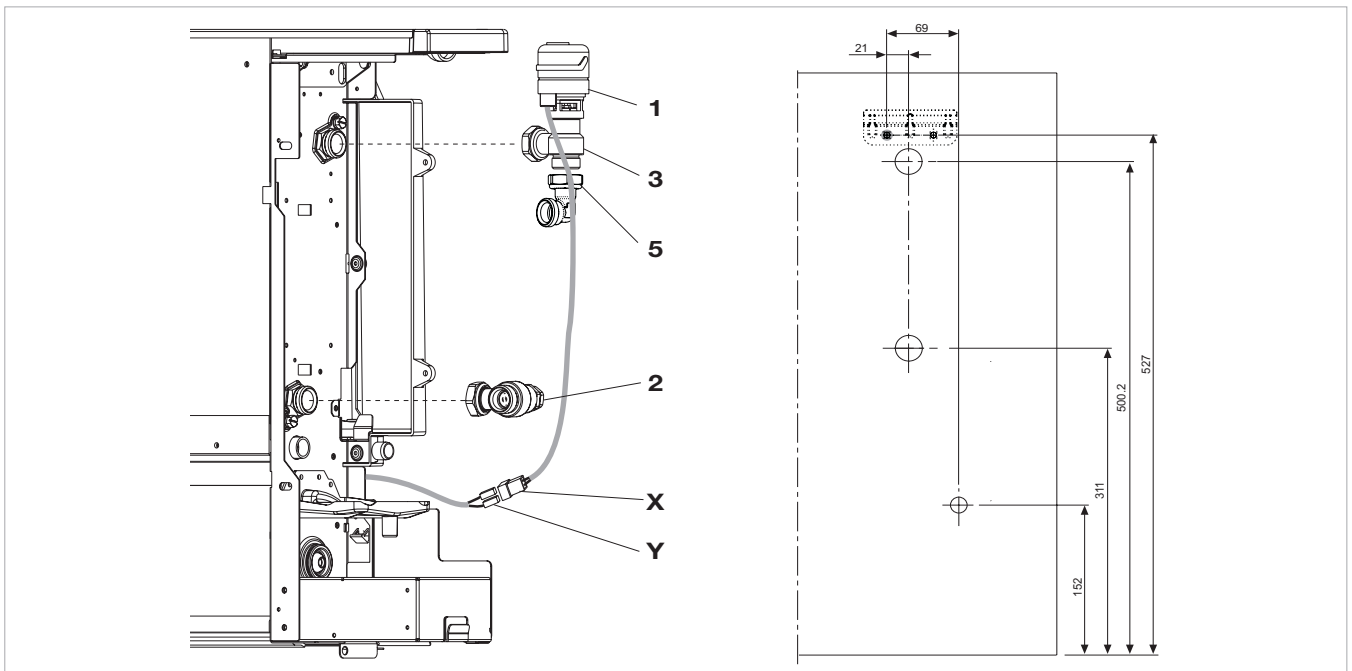
Floor mounted version, with optional 3/4" EK stub pipe (EKDIST)

1	thermo-electric head (n.1)	4	3/4" EK stub pipe (n.1 optional)
2	lockshield (n.1)	X	thermo-electric head connectors
3	2-way valve (n.1)	Y	wiring connectors



Wall mounted version, with optional 90° curved union (EKEUR90)

1	thermo-electric head (n.1)	5	90° union (n.1 optional)
2	lockshield (n.1)	X	thermo-electric head connectors
3	2-way valve (n.1)	Y	wiring connectors



FWX(V/M)-SERIES version with 3-way deviator valve (EK3VK1)

Consists of an automatic 3-way diverter valve with thermo-electric head and a lockshield, fitted with micrometric adjustment, capable of balancing the system load losses. The kit contains the insulation to be mounted on the valve and on the lockshield.

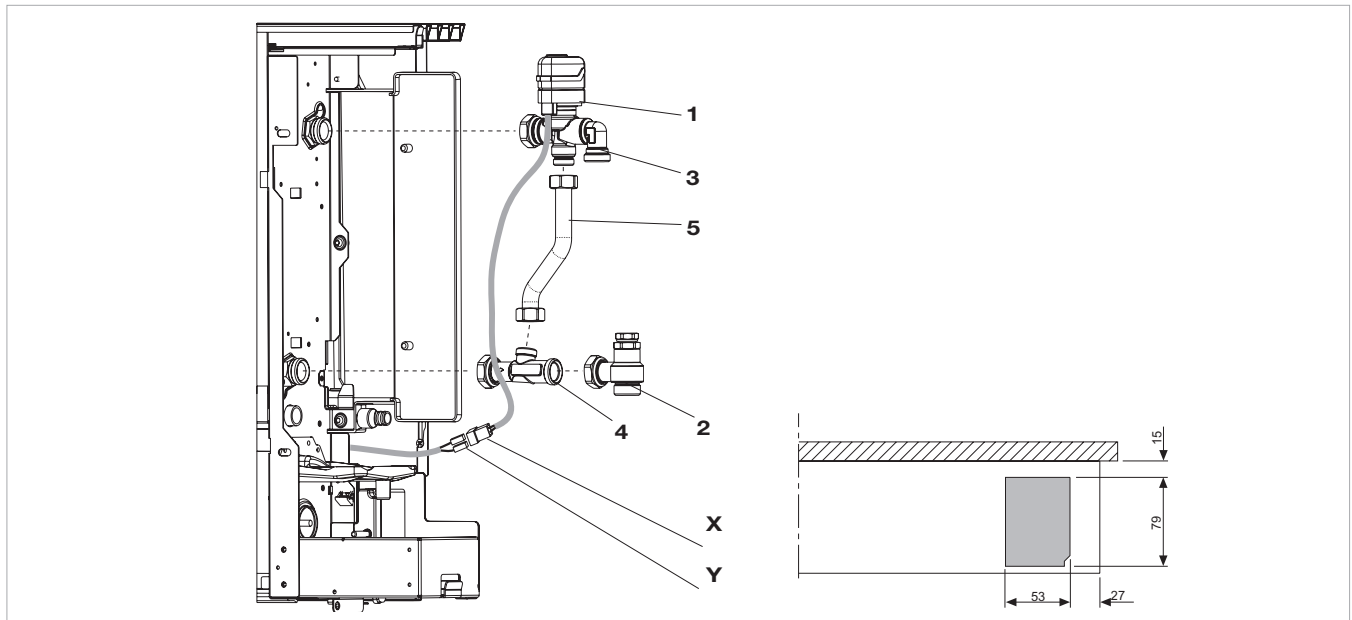
- Remove the side panel as indicated in paragraph Side opening.

- Assemble the components as indicated in figure
- Apply the supplied insulation.
- ⚠ When the hydraulic components have been mounted, connect the thermo-electric head connectors with the wiring connectors on the machine.

Floor mounted version

1	thermo-electric head (n.1)
2	lockshield (n.1)
3	3-way valve (n.1)
4	outlet union (n.1)

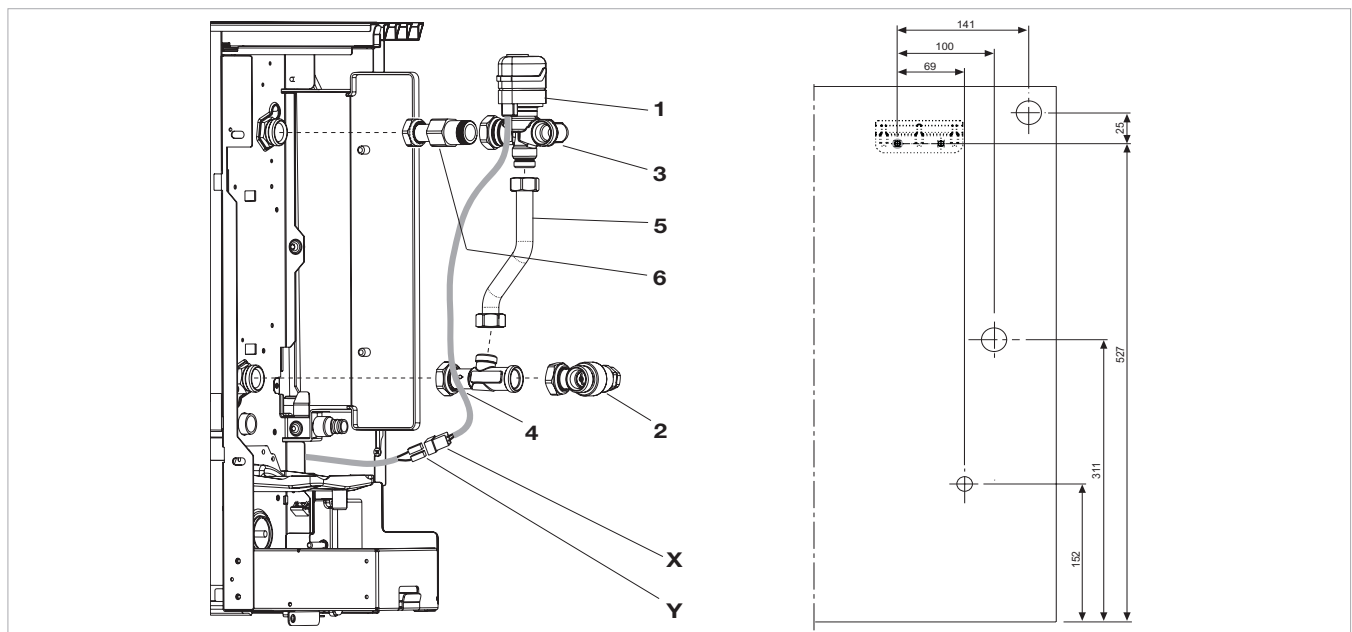
5	1/2" flexible tube 230 (n.1)
X	thermo-electric head connectors
Y	wiring connectors



Wall mounted version, with optional 3/4" EK stub pipe (EKDIST)

1	thermo-electric head (n.1)
2	lockshield (n.1)
3	3-way valve (n.1)
4	outlet union (n.1)

5	1/2" flexible tube 230 (n.1)
6	3/4" EK stub pipe (n.1 optional)
X	thermo-electric head connectors
Y	wiring connectors



EN

DAIKIN EUROPE N.V.

Zandvoordestraat 300, B-8400 Oostende, Belgium

Copyright 2019 Daikin

cod. N420252A