

MONTERINGSANVISNING

Reol Alna



Maks vekt på hver hylle må ikke overstige 265 kg.
Plasser de tyngste tingene på de laveste hyllene
og fordel jevnt.

Reolene er beregnet for innendørs bruk.

RKC

www.rkc.no



ADVARSEL!



Ta hensyn til kropp og løftestilling når du håndterer tunge gjenstander



Vær obs på skarpe kanter og bruk hansker og egnede sko/klær



Plasser produktet på et solidt og vannrett underlag. Fest i vegg om mulig. Produktet skal kun brukes som forevist









Ha nok plass til montering rundt deg. Ikke stå på eller bruk stige på produktet



Sorter og levér pakkingsmaterialene på forsvarlig måte

INNHOOLD

A	 5 stk Hylleplate	D	 10 stk Kort bjelke
B	 8 stk Vertikal stolpe	E	 4 stk Kobling
C	 10 stk Lang bjelke	F	 8 stk Beskyttelsesføtter
		G	 5 stk Midtbjelke

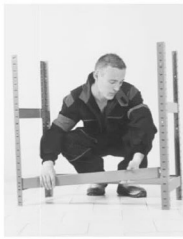

- 1a. Trè på beskyttelsesføttene (F)
- 1b. Monter nederste grunnramme (B, C, D, G)
- 1c. Monter hylle for hylle ferdig med hylleplater (C, D, G, A)
- 1d. Sett på koblinger (E) for neste høyde, og forleng rammen (B)
9. Fortsett å montere hylle for hylle i ønskede høyder (C, D, G, A)

MONTERINGSTIPS! Bruk en gummihammer el. for å forsiktig slå delene sammen slik at de sitter godt!

1

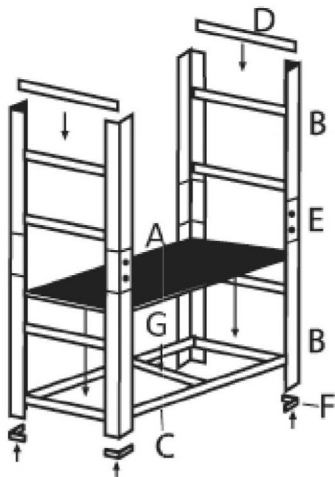

2

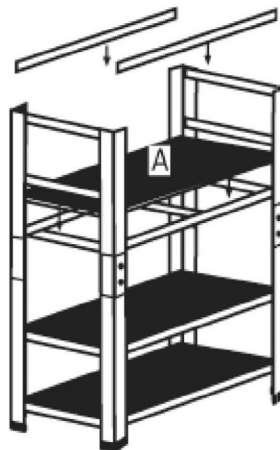

3

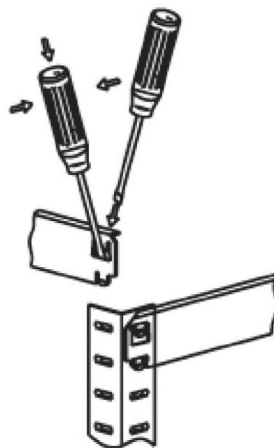
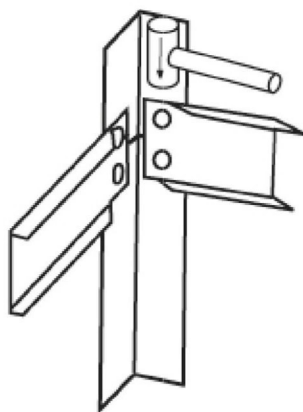
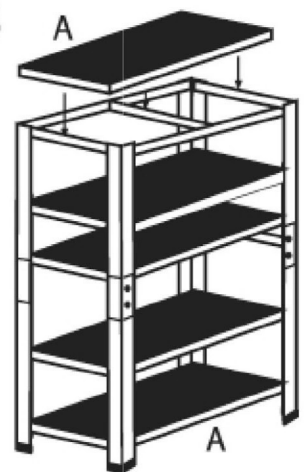

2