

European Technical Assessment

ETA 13/0334**Version 03****Date of issue: 2025-06-11****UBAtc Assessment Operator****Buildwise**Kleine Kloosterstraat 23
1932 Sint-Stevens-Woluwe
info@buildwise.be
www.buildwise.be**SECO****SECO Belgium**Registered office:
Cantersteen 47 1000 Bruxelles
Corporate office:
Hermeslaan 9 1831 Diegem
mail@seco.be - www.groupseco.be

**Technical Assessment Body issuing the European Technical Assessment: UBAtc.
UBAtc has been designated according to Article 29 of Regulation (EU) No 305/2011
and is member of EOTA (European Organisation for Technical Assessment)**

Trade name of the construction product:

Soudaseal FR

Product family to which the construction product belongs:

35 - Fire stopping sealant for fire stopping of linear gap seals

Manufacturer:SOUDAL NV
Everdongenlaan 18 - 20
B-2300 TURNHOUT
Belgium**Manufacturing plant(s):**SOUDAL NV
Plant 1 – Everdongenlaan 18-20
B-2300 TURNHOUT
Belgium**Website:**

www.soudal.com

This European Technical Assessment is issued in accordance with Regulation (EU) No 305/2011, on the basis of:

European Assessment Document (EAD):

EAD 350141-00-1106: "Fire stopping and fire sealing products: Linear joint and gap seals"

This version replaces:

ETA 13/0334 issued on 2021/10/11

This European Technical Assessment contains:

14 pages, including 4 annexes which form an integral part of this European Technical Assessment



European Organisation for Technical Assessment

Legal bases and general conditions

- 1 This European Technical Assessment is issued by UBAtc (Union belge pour l'Agrément technique de la construction, i.e. Belgian Union for technical Approval in construction), in accordance with:
 - Regulation (EU) No 305/2011 ⁽¹⁾ of the European Parliament and of the Council of 9 March 2011 laying down harmonised conditions for the marketing of construction products and repealing Council Directive 89/106/EEC
 - Commission Implementing Regulation (EU) No 1062/2013 ⁽²⁾ of 30 October 2013 on the format of the European Technical Assessment for construction products
 - European Assessment Document (EAD): EAD 350141-00-1106
- 2 Under the provisions of Regulation (EU) No 3205/2011, UBAtc is not authorized to check whether the provisions of this European Technical Assessment are met once the ETA has been issued.
- 3 The responsibility for the conformity of the performances of the products with this European Technical Assessment and the suitability of the products for the intended use remains with the holder of the European Technical Assessment.
- 4 Depending on the applicable Assessment and verification of constancy of performance (AVCP) system, (a) notified body(ies) may carry out third-party tasks in the process of assessment and verification of constancy of performance under this Regulation once the European Technical Assessment has been issued.
- 5 This European Technical Assessment allows the manufacturer of the construction product covered by this ETA to draw up a declaration of performance for the construction product.
- 6 CE marking should be affixed to all construction products for which the manufacturer has drawn up a declaration of performance.
- 7 This European Technical Assessment is not to be transferred to other manufacturers, agents of manufacturers, or manufacturing plants other than those indicated on page 1 of this European Technical Assessment.
- 8 The European Technical Assessment holder confirms to guarantee that the product(-s) to which this assessment relates, is/are produced and marketed in accordance with and comply with all applicable legal and regulatory provisions, including, without limitation, national and European legislation on the safety of products and services. The ETA-holder shall notify the UBAtc immediately in writing of any circumstance affecting the aforementioned guarantee. This assessment is issued under the condition that the aforementioned guarantee by the ETA-holder will be continuously observed.
- 9 According to Article 11(6) of Regulation (EU) No 305/2011, when making a construction product available on the market, the manufacturer shall ensure that the product is accompanied by instructions and safety information in a language determined by the Member State concerned which can be easily understood by users. These instructions and safety information should fully correspond with the technical information about the product and its intended use which the manufacturer has submitted to the responsible Technical Assessment Body for the issuing of the European Technical Assessment.
- 10 Pursuant to Article 11(3) of Regulation (EU) No 305/2011, manufacturers shall adequately take into account changes in the product-type and in the applicable harmonised technical specifications. Therefore, when the contents of the issued European Technical Assessment do not any longer correspond to the product-type, the manufacturer should refrain from using this European Technical Assessment as the basis for their declaration of performance.
- 11 All rights of exploitation in any form and by any means of this European Technical Assessment are reserved for UBAtc and the ETA-holder, subject to the provisions of the applicable UBAtc regulations.
- 12 Reproduction of this European Technical Assessment including transmission by electronic means shall be in full. However, partial reproduction can be made with the written consent of UBAtc. In this case partial reproduction has to be designated as such. Texts and drawings of advertising brochures shall not contradict or misuse the European Technical Assessment.
- 13 Subject to the application introduced, this European Technical Assessment is issued in English and may be issued by the UBAtc in its official languages. The translations correspond fully to the English reference version circulated in EOTA.
- 14 A European Technical Approval (ETA) was first issued by UBAtc on 27 June 2013 and was reissued as a European Technical Assessment on 7 August 2017 without technical changes. New fire resistance classifications were included in a version issued on 11 October 2021, extending the intended use to concrete wall elements and prefabricated reinforced concrete sandwich panels. This ETA 13/0334 is superseded by the current European Technical Assessment, identified as version 3, issued on 11th June 2025 and includes additional fire resistance classifications for rigid wall applications.

⁽¹⁾: OJEU, L 88 of 2011/04/04

⁽²⁾: OJEU, L 289 of 2013/10/31

Technical Provisions

1 Technical description of the product

1.1 Characteristics of the products

This European Technical Assessment is being issued for Soudaseal FR on the basis of agreed data/information, deposited with the UBAtc, which identifies the product that has been assessed. Changes to the product/production process, which could result in the deposited data/information being incorrect, should be notified to the UBAtc before the changes are introduced. The UBAtc will decide whether or not such changes affect the ETA and consequently the validity of the CE marking on the basis of the ETA and if so whether further assessment/alterations to the ETA, shall be necessary.

1.2 Soudaseal FR

Soudaseal FR is a one component fire retardant sealant based on a silyl modified polymer (MS-Polymer). It is delivered in white and grey.

Installation of Soudaseal FR: see clause 2.4.2.

2 Specification of the intended use in accordance with the applicable EAD

2.1 Intended use

Soudaseal FR is intended to be used as a fire stopping sealant for non-movement joints and seals in rigid and flexible walls and rigid floors (see Annex III).

The specific elements of construction for which Soudaseal FR may be used to provide a linear joint seal, are as follows:

- Rigid walls: the wall shall have a minimum thickness of 100 mm, 140 mm or 200 mm and comprise concrete or masonry with a minimum density of 550 kg/m³.
- Flexible walls: light weight flexible wall (≥EI 30 and ≥EI 90) conforming the provisions given in EN 1363-1:2020, clause 7.2.2.4 and EN 1366-4:2021. See details in annex III.
- Full concrete wall panels (tongue-and-groove) existing of reinforced prefabricated concrete panels according to EN 14992 and prefabricated slotted concrete columns according to EN 13225. See details in annex III.
- Prefabricated reinforced concrete sandwich panels with internal insulation according EN 14992 and prefabricated concrete columns according to EN 13225. See details in annex III.
- Rigid floors: the floor shall have a minimum thickness of 150 mm and comprise concrete with a minimum density of 600 kg/m³.

The supporting construction shall be classified according to EN 13501-2 for the required fire resistance period.

As backfilling material, Soudafoam FR HY or a backer rod based on polyethylene (PE) or polyurethane (PU) may be used. For a specification of the suitable material see Annex II.

2.2 Use category

The use category for Soudaseal FR is Z_{2(+5/+40)} intended for use the following environmental conditions:

Table 1 – intended use

Environmental conditions	EAD 350141-00-1106 Type
Internal conditions with humidity classes other than Z ₁ , excluding temperatures below 0 °C	Z ₂

2.3 Working life/Durability

The provisions made in this European Technical Assessment are based on an assumed intended working life of 10 years.

Indications given regarding the working life cannot be interpreted as a guarantee given by the producer or the UBAtc, but are to be regarded only as a means for choosing the appropriate product(s) in relation to the expected economically reasonable working life of the construction works.

2.4 Assumptions under which the product was assessed

2.4.1 Manufacturing directives

The fire stopping and sealing product Soudaseal FR is manufactured and packaged by Soudal NV in Turnhout, Belgium.

2.4.2 Installation

Installation shall be performed by trained installers.

Preparation of the surface:

- Soudaseal FR adheres to most substrates (concrete, masonry, gypsum, etc) without a primer. Very porous substrates should be pre-treated with Primer 150. Non-porous substrates may be pre-treated with Surface Activator.
- The surface shall be clean, dry, and free of dust, oil and grease.

Joint size:

- Width: up to 50 mm;
- Depth: the same as thickness of the wall or floor.

Application of the Soudaseal FR:

- Application temperature: between +5 °C and + 30 °C.
- Insert backing material if applicable.
- Apply Soudaseal FR with a manual- or pneumatic caulking gun.
- Smoothen the sealant surface before skin formation with a soapy solution or Soudal Finishing Solution.

2.4.3 Packaging, transport and storage

Soudaseal FR is available in foil bags (600 ml) and in cartridges (290 ml).

The product has a shelf life of at least 12 months in unopened packaging when stored in a dry place between +5 °C and +25 °C.

2.4.4 Curing behaviour

- Curing rate: 2 mm/24 h
- Skin formation time: Approx. 10 min.
- Volume shrinkage: 1 %
- Density according to EN 542:2003: 1,55 g/cm³

2.4.5 Use, maintenance and repair

Soudaseal FR does not need any maintenance during the working life indicated in this ETA.

Local repairs may be performed according to the manufacturer instructions.

3 Performance of the product and references to the methods used for its assessment

3.1 Safety in the case of fire (BWR2)

3.1.1 Reaction to fire

The reaction to fire classification of Soudaseal FR is class E according to EN 13501-1.

3.1.2 Resistance to fire

Soudaseal FR has been tested in accordance with EN 1366-4:2021, installed in linear joint seals in rigid walls and floors. As backfilling material Soudafoam FR HY, a PU or PE backer rod has been used.

In addition, Soudaseal FR has been tested in accordance with EN 1366-4:2021, installed in linear joint seals in lightweight flexible wall systems according to the provisions of EN 1363-1:2020, clause 7.2.2.4.

Soudaseal FR has also been tested in accordance with EN 1366-4:2021, installed in linear joint seals in a prefabricated concrete wall panel systems and a prefabricated reinforced concrete sandwich panel system with internal insulation as specified in Annex III and annex IV.

Based upon these test results and the field of direct application specified in EN 1366-4:2021, Soudaseal FR has been classified in accordance with EN 13501-2 (see Annex III).

3.2 Hygiene, health and environment (BWR3)

No performance assessed.

3.3 Safety in use (BWR4)

3.3.1 Mechanical resistance and stability

The maximum joint width is 50 mm. According to EAD 350141-00-1106, impact tests are not required.

3.3.2 Resistance to impact/movement

This test is not required as the maximum joint width is less than 150 mm.

3.3.3 Adhesion

Adhesion has been assessed according to EN ISO 11600. Soudaseal FR is a sealant classified as 25LM.

3.3.4 Durability

Soudaseal FR has been assessed in accordance with EAD 350141-00-1106 for the environmental category $Z_{2(S/+40)}$.⁽³⁾

3.3.5 Movement capability

Classification according to EN ISO 11600: 25LM

3.3.6 Cycling of perimeter seals for curtain walls

No performance assessed.

3.3.7 Compression set

No performance assessed.

3.3.8 Linear expansion on setting

No performance assessed.

3.4 Protection against noise (BWR5)

No performance assessed.

3.5 Energy economy and heat retention (BWR6)

No performance assessed.

4 Assessment and verification of constancy of performance (AVCP) system applied, with reference to its legal base

For the products covered by EAD 350141-00-1106 the applicable European legal act is Decision 1999/454/EC (EU).⁽⁴⁾

The system is: system 1.

5 Technical details necessary for the implementation of the AVCP system, as foreseen in the applicable EAD

5.1 Tasks for the ETA-holder

5.1.1 Factory production control (FPC)

The manufacturer shall exercise permanent internal control of production. All the elements, requirements and provisions adopted by the manufacturer shall be documented in a systematic manner in the form of written policies and procedures, including records of results performed. This production control system shall ensure that the product is in conformity with this ETA.

The manufacturer may only use constituent materials stated in the technical documentation of this ETA.

The factory production control shall be in accordance with the "Control Plan" relating to the ETA which is part of the technical documentation of this ETA. The "Control Plan" is laid down in the context of the factory production control system operated by the manufacturer and deposited at the UBAtc and shall be in agreement with the provisions given in Table 3.2 of EAD 350141-00-1106.

The results of factory production control shall be recorded and evaluated in accordance with the provisions of the "Control Plan".

5.2 Tasks of notified bodies

The notified body (bodies) shall perform the tasks specified in Regulation (EU) N° 305/2011, Annex V, clause 1.2 (b).

The notified body (bodies) shall retain the essential points of its (their) actions referred to above and state the results obtained and conclusions drawn in (a) written report (reports).

In cases where the provisions of the ETA and its "Control Plan" are no longer fulfilled the notified body shall inform the UBAtc without delay.

⁽³⁾: see also EOTA Technical Report TR 024 – Edition November 2006, clause 4.2.7

⁽⁴⁾: OJEU, L 178/52 of 1999/07/14, p.3

Annex I: Reference documents

References to standards mentioned in the ETA:

EAD 350141-00-1106:2017	Fire stopping and fire sealing products: linear joint and gap seals
EN 206:2013+A2:2021	Concrete - Specification, performance, production and conformity
EN 520:2004+A1:2009	Gypsum plasterboards - Definitions, requirements and test methods
EN 542:2003	Adhesives - Determination of density
EN 1363-1:2020	Fire resistance tests - Part 1: General requirements
EN 1366-4:2021	Fire resistance tests for service installations - Part 4: Linear joint seals
EN 13225:2013	Precast concrete products - Linear structural elements
EN 13501-1:2018	Fire classification of construction products and building elements – Part 1: Classification using test data from reaction to fire tests
EN 13501-2:2023	Fire classification of construction products and building elements – Part 2: Classification using test data from fire resistance tests
EN 14992:2007+A1:2012	Precast concrete products - Wall elements
EN ISO 11600:2004+A1:2011	Building construction — Jointing products — Classification and requirements for sealants

Other reference documents:

EOTA TR 024:2019	Characterization, Aspects of Durability and Factory Production Control for Reactive Materials, Components and Products
------------------	--

Annex II: Description of the products

1. Primer 150

Primer for very porous surfaces.

2. Surface Activator

Primer for non-porous surfaces.

3. Soudal Finishing Solution

Soapy solution for smoothening the sealant surface before skin formation.

4. Backfilling materials

4.1 General

The backfilling materials only serve to limit the thickness of the sealant and have no influence on the fire resistance of the sealant.

4.2 Soudafoam FR HY

Soudafoam FR HY is one-component self-expanding fire retardant polyurethane foam, as specified in ETA 21/0659.

4.3 PE-backer rod

Round profiles from closed-cell polyethylene used as a non-adhesive backfilling to ensure the correct dimension of the joint.

Diameter: 10 – 25 mm.

4.4 PU-backer rod

Round profiles from open cell polyurethane foam used as a non-adhesive backfilling to ensure correct dimension of the joint.

Diameter: 15 – 50 mm.

Annex III: Resistance to fire classification of linear joint seals made with Soudaseal FR

1. Linear joints in rigid walls made of concrete or brick

1.1 Soudaseal FR with Soudafoam FR HY as specified in annex II as backfilling material:

Thickness of the wall (mm)	Density of the wall (kg/m ³)	Orientation of the joint	Symmetrical / Asymmetrical	Composition of the joint seal	Classification
100	550	Vertical	Asymmetrical	The exposed side is filled throughout a depth of 20 mm with Soudaseal FR and the unexposed (*) side is further filled with Soudafoam FR HY up to the sealant	EI120 – V – X – F – W0 to W10
100	550	Vertical	Asymmetrical	The exposed side is filled throughout a depth of 20 mm with Soudaseal FR and the unexposed (*) side is further filled with Soudafoam FR HY up to the sealant	EI90 – V – X – F – W0 to W20
100	550	Vertical	Asymmetrical	The unexposed (*) side is filled throughout a depth of 20 mm with Soudaseal FR and the exposed side is further filled with Soudafoam FR HY up to the sealant	EI120 – V – X – F – W0 to W20
100	550	Vertical	Symmetrical	The exposed and unexposed (*) side is filled throughout a depth of 20 mm with Soudaseal FR the empty space in between is filled up with Soudafoam FR HY (60 mm)	EI120 – V – X – F – W0 to W30
140	550	Horizontal	Asymmetrical	The exposed side is filled throughout a depth of 20 mm with Soudaseal FR and the unexposed (*) side is further filled with Soudafoam FR HY up to the sealant	EI90 – T – X – W0 to W30
140	550	Horizontal	Symmetrical	The exposed and unexposed (*) side is filled throughout a depth of 20 mm with Soudaseal FR the empty space in between is filled up with Soudafoam FR HY (100 mm)	EI120 – T – X – W0 to W30
200	550	Vertical	Asymmetrical	The exposed side is filled throughout a depth of 20 mm with Soudaseal FR and the unexposed (*) side is further filled with Soudafoam FR HY up to the sealant	EI240 – V – X – F – W0 to W20
200	550	Vertical	Asymmetrical	The exposed side is filled throughout a depth of 20 mm with Soudaseal FR and the unexposed (*) side is further filled with Soudafoam FR HY up to the sealant	EI180 – V – X – F – W0 to W40
200	550	Vertical	Symmetrical	The exposed and unexposed (*) side is filled throughout a depth of 20 mm with Soudaseal FR the empty space in between is filled up with Soudafoam FR HY (160 mm)	EI180 – V – X – F – W0 to W40

(*) The unexposed side is the side that is on the opposite side of the fire.

1.2 Soudaseal FR with a PE-backer / PU-backer rod as specified in annex II as backfilling material

Thickness of the wall (mm)	Density of the wall (kg/m ³)	Orientation of the joint	Symmetrical / Asymmetrical	Composition of the joint seal	Classification
200	550	Vertical	Asymmetrical	The unexposed (*) side is filled throughout a depth of 15 mm with Soudaseal FR and is further provided with a compressed backer rod of PE foam	EI240 – V – X – W0 to W15
200	550	Vertical	Symmetrical	Both the exposed and the unexposed (*) sides are filled throughout a depth of 20 mm with Soudaseal FR and further provided with a compressed PE backer rod	EI240 – V – X – W0 to W30
115	600	Vertical	Symmetrical	Both the exposed and the unexposed (*) sides are filled throughout a depth of 20 mm with Soudaseal FR and further provided with a compressed PU backer rod	EI120 – T – X – F – W0 to W30

Thickness of the wall (mm)	Density of the wall (kg/m ³)	Orientation of the joint	Symmetrical / Asymmetrical	Composition of the joint seal	Classification
115	600	Vertical	Asymmetrical	The unexposed (*) side is filled throughout a depth of 15 mm with Soudaseal FR and is further provided with a compressed PU backer rod	E120 – V – X – F – W0 to W20
140	550	Horizontal	Symmetrical	The exposed and unexposed (*) side is filled throughout a depth of 20 mm with Soudaseal FR and is further provided with a compressed backer rod of PU foam (40 mm diameter)	E120 – T – X – W0 to W30
140	550	Horizontal	Asymmetrical	The exposed side is filled throughout a depth of 20 mm with Soudaseal FR and is further provided with a compressed backer rod of PU foam (15 mm diameter for widths less than 10 mm, 40 mm diameter for higher widths)	E120 – T – X – W0 to W30 E120 – T – X – W0 to W30
140	550	Horizontal	Asymmetrical	The exposed side is filled throughout a depth of 20 mm with Soudaseal FR and is further provided with a compressed backer rod of PU foam (40 mm diameter)	E130 – T – X – W0 to W20 E120 – T – X – W0 to W20

(*) The unexposed side is the side that is on the opposite side of the fire.

2. Linear joints in lightweight flexible walls

The lightweight flexible wall is build-up according to the provisions of EN 1363-1:2020, clause 7.2.2.4 and EN 1366-4:2021.

Build-up of the walls:

1. Lightweight partition walls \geq EI 30 (height = 3000 mm; width = 1200 mm; thickness = 75 mm)
 - Metal framework made of U- and C-shaped sections (Group A: width 50 mm)
 - A single layer of plasterboard (type F according to EN 520) with thickness: 12.5 mm on both sides
 - Insulation of rock wool (thickness: 50 mm, density: 35 kg/m³).
2. Lightweight partition walls \geq EI 90 (height = 3000 mm; width = 1200 mm; thickness = 100 mm)
 - Metal framework made of U- and C-shaped sections (Group A: width 50 mm)
 - Double layer of plasterboard (type F according to EN 520) with thickness: 12.5 mm on both sides
 - Insulation of rock wool (thickness: 50 mm, density: 90 kg/m³).

Thickness of the wall (mm)	Orientation of the joint	Symmetrical / Asymmetrical	Composition of the joint seal	Classification
75	Vertical	symmetrical	Both the exposed and the unexposed (*) sides are completely (12,5 mm) filled with Soudaseal FR.	EI60 – V – X – F – W0 to W20
75	horizontal	symmetrical	Both the exposed and the unexposed (*) sides are completely (12,5 mm) filled with Soudaseal FR.	EI60 – T – X – F – W0 to W20
100	Vertical	symmetrical	Both the exposed and the unexposed (*) sides are completely (25 mm) filled with Soudaseal FR.	EI120 – V – X – F – W0 to W20
100	horizontal	symmetrical	Both the exposed and the unexposed (*) sides are completely (25 mm) filled with Soudaseal FR.	EI120 – T – X – F – W0 to W20

(*) The unexposed side is the side that is on the opposite side of the fire.

3. Linear joints in prefabricated full concrete wall panels

Full concrete wall panels (tongue-and-groove) existing of reinforced prefabricated concrete panels according to EN 14992 and prefabricated slotted concrete columns according to EN 13225. The build-up of the test set-up is described underneath and is illustrated in figure 4 in Annex IV.

- Tongue-and-groove concrete wall panels:
 - Concrete class according to EN 206: C30/37
 - Thickness = 140 mm
 - Density = 2450 kg/m³
 - Bevel: 15mm x 45° at the outer ribs
 - Reinforcement:
 - 2 x steel mesh 150/5
 - Diameter = 5 mm
 - Mesh size = 150 mm
 - Concrete cover = 30 mm

- Slotted concrete columns:

Slotted concrete columns 45x25	Slotted concrete columns 60x60
<ul style="list-style-type: none"> • Concrete class according to EN 206: C30/37 • Dimensions: 450 mm x 250 mm • Slot dimensions: 155 mm x 75 mm • Density = 2450 kg/m³ • Bevel: 15mm x 45° at the outer ribs • Reinforcement: <ul style="list-style-type: none"> ○ 10 vertical bars with steel stirrups every 150 mm ○ Diameter = 12 mm ○ Stirrup diameter = 8 mm ○ Concrete cover = 30 mm 	<ul style="list-style-type: none"> • Concrete class according to EN 206: C30/37 • Dimensions: 600 mm x 600 mm • Slot dimensions: 155 mm x 75 mm • Density = 2450 kg/m³ • Bevel: 15mm x 45° at the outer ribs • Reinforcement: <ul style="list-style-type: none"> ○ 12 vertical bars with steel stirrups every 150 mm ○ Diameter = 35 mm ○ Stirrup diameter = 8 mm ○ Concrete cover = 40 mm

Thickness of the wall (mm)	Column	Orientation of the joint	Joint seal Symmetrical / Asymmetrical	Composition of the joint seal	Classification
140	-	horizontal	asymmetrical	the exposed side is filled with Soudaseal FR. Thickness = 20 mm	EI120 – T – X – F – W0 to W15
140	-	horizontal	asymmetrical	the unexposed (*) side is filled with Soudaseal FR. Thickness = 20 mm	EI120 – T – X – F – W0 to W15
140	-	horizontal	symmetrical	both the exposed and unexposed (*) sides are filled with Soudaseal FR. Thickness = 20 mm	EI120 – T – X – F – W0 to W15
140	slotted symmetrical	vertical	asymmetrical	the exposed side is filled with Soudaseal FR. Thickness = 20 mm	EI120 – T – X – F – W0 to W15
140	slotted symmetrical	vertical	asymmetrical	the unexposed (*) side is filled with Soudaseal FR. Thickness = 20 mm	EI120 – T – X – F – W0 to W15
140	slotted symmetrical	vertical	symmetrical	both the exposed and unexposed (*) sides are filled with Soudaseal FR. Thickness = 20 mm	EI120 – T – X – F – W0 to W15

(*) The unexposed side is the side that is on the opposite side of the fire.

4. Linear joints in prefabricated reinforced concrete sandwich panels with internal insulation

Prefabricated reinforced concrete sandwich panels with internal insulation according to EN 14992 and prefabricated concrete columns according to EN 13225. The build-up of the test set-up is described underneath and is illustrated in Fig. 3 in Annex IV.

- Prefabricated insulated reinforced concrete sandwich panels 20 cm
 - Concrete class according to EN 206: C30/37
 - Total thickness = 200 mm
 - Build-up: 60 mm concrete + 30 mm PIR insulation + 110 mm concrete
 - Density of the concrete = 2450 kg/m³
 - Density of the PIR Insulation = 30 kg/m³
 - Bevel: 15mm x 45° at the outer ribs
 - Reinforcement:

60 mm concrete	110 mm concrete
<ul style="list-style-type: none"> • 1 x Steel mesh 100/5 • Diameter = 5 mm • Mesh size = 100 mm • Concrete cover = 30 mm 	<ul style="list-style-type: none"> • 1 x Steel mesh 150/5 • Diameter = 5 mm • Mesh size = 150 mm • Concrete cover = 30 mm

- Prefabricated insulated reinforced concrete sandwich panels 28 cm
 - Concrete class according to EN 206: C30/37
 - Total thickness = 280 mm
 - Build-up: 70 mm concrete + 100 mm PIR insulation + 110 mm concrete
 - Density of the concrete = 2450 kg/m³
 - Density of the PIR Insulation = 30 kg/m³
 - Bevel: 15mm x 45° at the outer ribs
 - Reinforcement:

70 mm concrete	110 mm concrete
<ul style="list-style-type: none"> • 1 x Steel mesh 100/5 • Diameter = 5 mm • Mesh size = 100 mm • Concrete cover = 30 mm 	<ul style="list-style-type: none"> • 1 x Steel mesh 150/5 • Diameter = 5 mm • Mesh size = 150 mm • Concrete cover = 30 mm

- Rectangular concrete columns 30 x 20
 - Concrete class according to EN 206: C30/37
 - Dimensions: 300 mm x 200 mm
 - Density = 2450 kg/m³
 - Bevel: 15mm x 45° at the outer ribs
 - Reinforcement:
 - 8 vertical bars with steel stirrups every 150 mm
 - Diameter = 12 mm
 - Stirrup diameter = 8 mm
 - Concrete cover = 30 mm

Thickness of the wall (mm)	Column		Orientation of the joint	Joint seal Symmetrical / Asymmetrical	Composition of the joint seal	Classification
	type	position				
200	-		horizontal	asymmetrical	the exposed side is filled with Soudaseal FR. Thickness = 20 mm	EI120 – T – X – F – W0 to W15
200	-		horizontal	asymmetrical	the unexposed (*) side is filled with Soudaseal FR. Thickness = 20 mm	EI120 – T – X – F – W0 to W15
280	-		horizontal	asymmetrical	the exposed side is filled with Soudaseal FR. Thickness = 20 mm	EI120 – T – X – F – W0 to W20
280	-		horizontal	asymmetrical	the unexposed (*) side is filled with Soudaseal FR. Thickness = 20 mm	EI120 – T – X – F – W0 to W20
200	rectangular	exposed side	vertical	asymmetrical	the exposed side is filled with Soudaseal FR. Thickness = 20 mm	EI120 – T – X – F – W0 to W20
200	rectangular	exposed side	vertical	asymmetrical	the unexposed (*) side is filled with Soudaseal FR. Thickness = 20 mm	EI120 – T – X – F – W0 to W20
280	rectangular	exposed side	vertical	asymmetrical	the exposed side is filled with Soudaseal FR. Thickness = 20 mm	EI120 – T – X – F – W0 to W20
280	rectangular	exposed side	vertical	asymmetrical	the unexposed (*) side is filled with Soudaseal FR. Thickness = 20 mm	EI120 – T – X – F – W0 to W20

(*) The unexposed side is the side that is on the opposite side of the fire.

5. Linear joints in rigid floor constructions

5.1 Soudaseal FR with Soudafoam FR HY as specified in annex II as backfilling material

Thickness of the floor (mm)	Density of the floor (kg/m ³)	Orientation of the joint	Symmetrical / Asymmetrical	Composition of the joint seal	Classification
150	550	Horizontal	Asymmetrical	The exposed side is filled throughout a depth of 20 mm with Soudaseal FR and the unexposed (*) side is further filled with Soudafoam FR HY up to the sealant	EI120 – H – X – F – W0 to W40
150	550	Horizontal	Asymmetrical	The unexposed (*) side is filled throughout a depth of 20 mm with Soudaseal FR and the exposed side is further filled with Soudafoam FR HY up to the sealant	EI120 – H – X – F – W0 to W50

(*) The unexposed side is the side that is on the opposite side of the fire.

5.2 Soudaseal FR with a PE-backer / PU-backer rod as specified annex II as backfilling material

Thickness of the floor (mm)	Density of the floor (kg/m ³)	Orientation of the joint	Symmetrical / Asymmetrical	Composition of the joint seal	Classification
150	600	Horizontal	Symmetrical	Both the exposed and the unexposed (*) sides are filled throughout a depth of 20 mm with Soudaseal FR and further provided with a compressed PU backer rod	EI120 – H – X – F - W0 to W30
150	600	Horizontal	Asymmetrical	The unexposed (*) side is filled throughout a depth of 15 mm with Soudaseal FR and is further provided with a compressed PU backer rod	EI120 – H – X – F - W0 to W20
150	600	Horizontal	Asymmetrical	The unexposed (*) side is filled throughout a depth of 20 mm Soudaseal FR and is further provided with a compressed PU backer rod	EI90 – H – X – F - W0 to W30 EI120 – H – X – F - W0 to W30
150	600	Horizontal	Symmetrical	Both the exposed and the unexposed (*) sides are filled throughout a depth of 15 mm with Soudaseal FR and on both sides further provided with a compressed PU backer rod	EI120 – H – X – F - W0 to W20
(*) The unexposed side is the side that is on the opposite side of the fire.					

Annex IV: detail drawings of build-up of walls for fire resistance testing

1. Linear joints in prefabricated full concrete wall panels

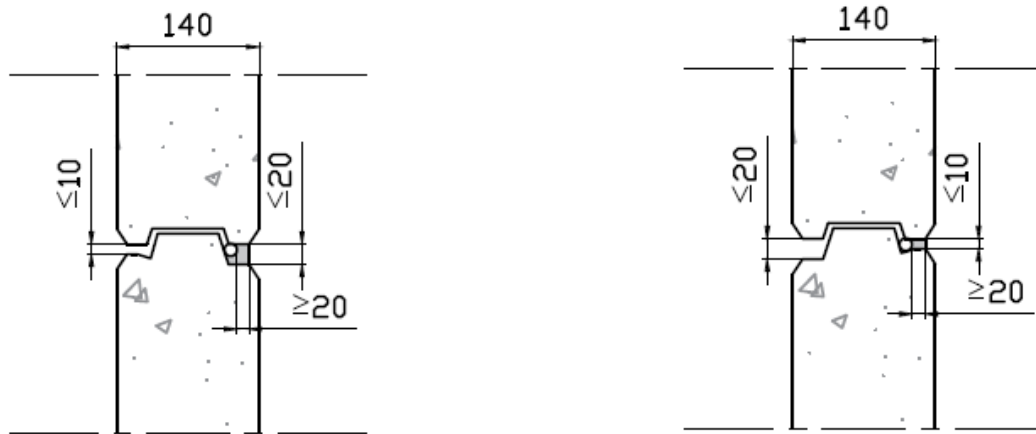

Fig. 1 – full concrete wall panels

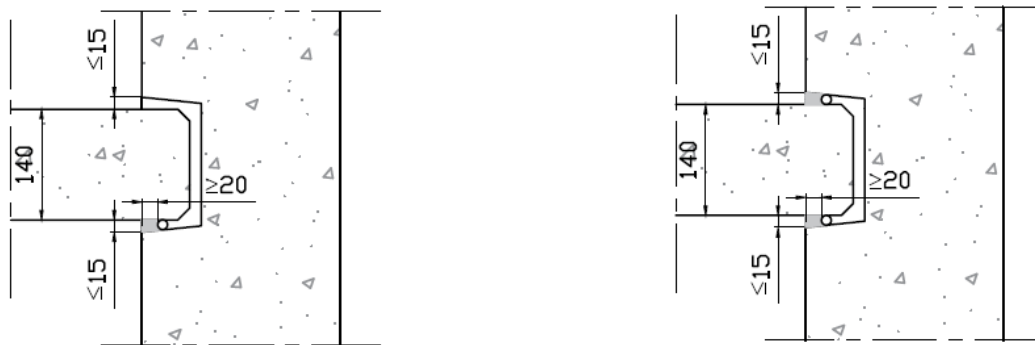

Fig. 2 – full concrete wall panels + column

2. Linear joints in prefabricated reinforced concrete sandwich panels with internal insulation

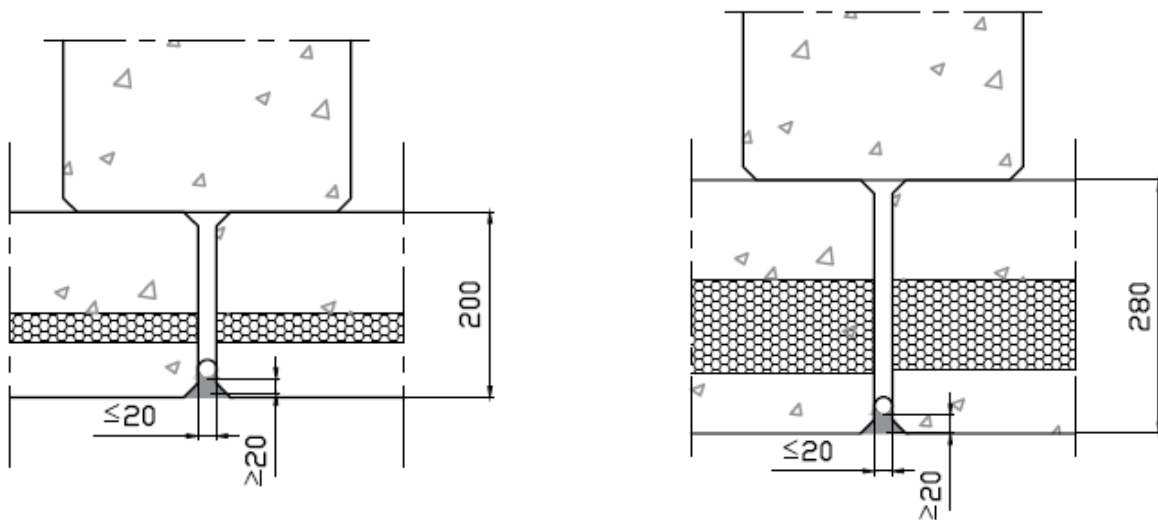

Fig. 3 – concrete sandwich panels (left 20 cm, right 28 cm) + column

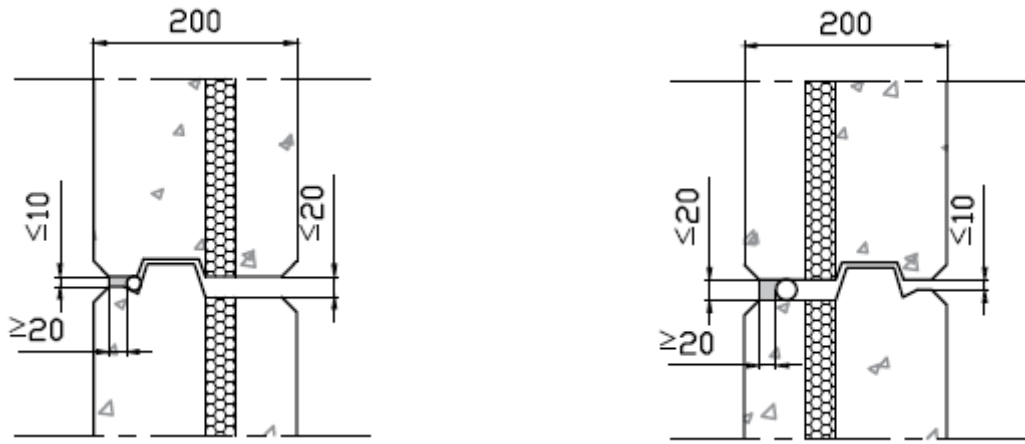

Fig. 4 – full concrete wall panels (20 cm)

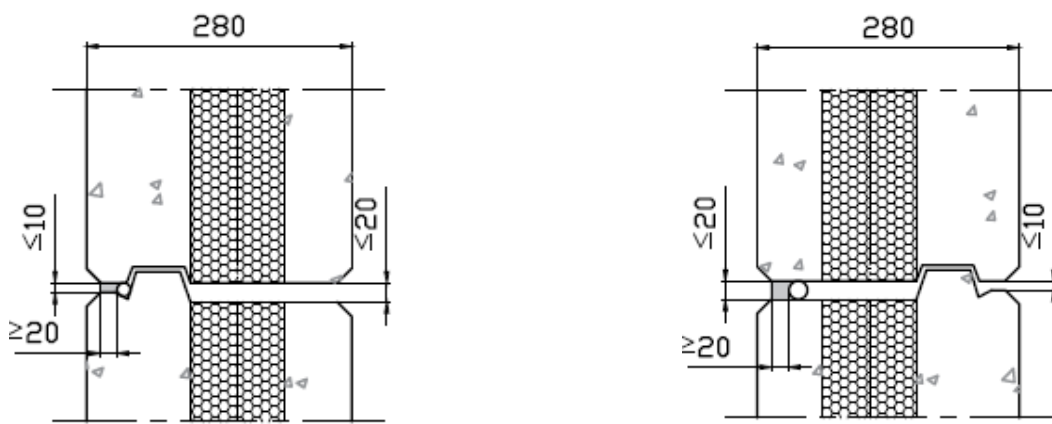

Fig. 5 – full concrete wall panels (28 cm)

UBA_{tc} asbl is a non-profit organization according to Belgian law. It is a Technical Assessment Body notified by the Belgian notifying authority, the Federal Public Services Economy, SMEs, Self-Employed and Energy, on 17 July 2013 in the framework of Regulation (EU) No 305/2011 of the European Parliament and of the Council of 9 March 2011 laying down harmonised conditions for the marketing of construction products and repealing Council Directive 89/106/EEC and is member of the European Organisation for Technical Assessment, EOTA (www.eota.eu).

This European Technical Assessment has been issued by UBA_{tc} asbl, in Sint-Stevens-Woluwe, on the basis of the technical work carried out by the Assessment Operators, Buildwise and SECO Belgium.

On behalf of UBA_{tc} asbl,

On behalf of the Assessment Operator,
Buildwise and SECO Belgium, responsible for the
technical content of the ETA,



Eric Winnepenninckx,
director



Frederic De Meyer,
director



Olivier Vandooren,
CEO Buildwise



Bernard Heiderscheidt,
CEO SECO Belgium

The most recent version of this European Technical Assessment may be consulted on the UBA_{tc} website (www.butgb-ubatc.be).