

MULTI-MONTI®

Technical Manual

Stand 05/2011

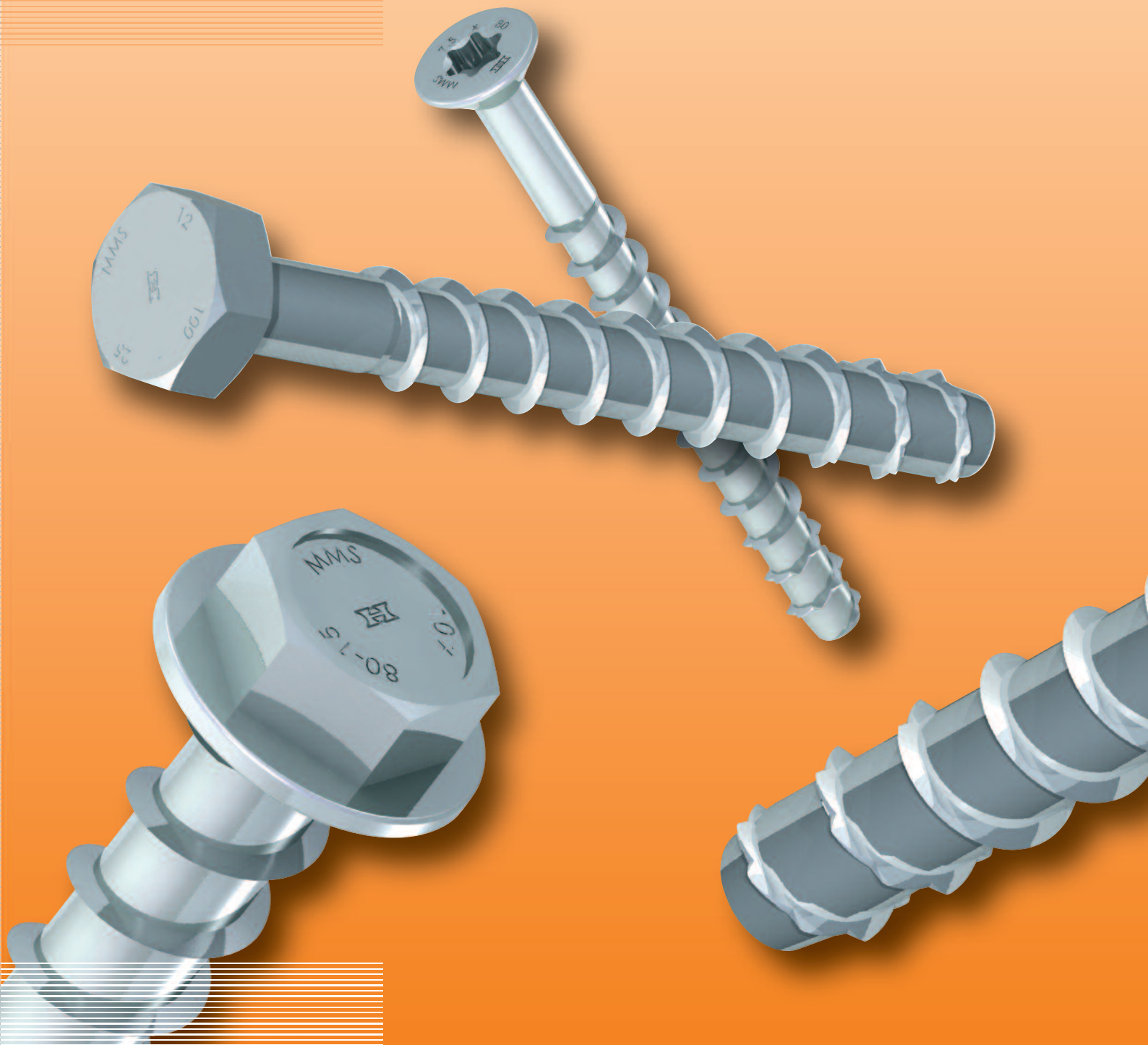

Technical Manual

HECO-MULTI-MONTI®

Contents

Instructions for fixing		P. 3
Chapter 1 :	Admissible loads in concrete as well as anchor-characteristics for MMS-6 to MMS-16	P. 4
	1.1 admissible loads as well as anchor-characteristics for fixations in cracked and non-cracked concrete with MULTI-MONTI®-Screw-In-Anchors MMS-7,5 to MMS-16	
	1.2 admissible loads as well as anchor-characteristics for fixations of lightweight systems and for fixations in non-cracked concrete with MULTI-MONTI®-Screw-In-Anchors MMS-6 to MMS-10	
Chapter 2 :	Recommended loads for fixations in concrete and brickwork as well as anchor characteristics for MULTI-MONTI®-Screw-In-Anchors HMS-5 to MMS-20	P. 6
	2.1 recommended loads for fixations in cracked and non-cracked concrete with MULTI-MONTI®-Screw-In-Anchors HMS-5 to MMS-20	
	2.2 recommended loads for fixations in brickwork with MULTI-MONTI®-Screw-In-Anchors HMS-5 to MMS-12	
	2.3 recommended loads for fire prevention F-30 to F-120 in concrete and brickwork for MULTI-MONTI®-Screw-In-Anchors HMS-5 to MMS-12	
Chapter 3 :	Products	P. 8

Instructions for fixing

The fixing-system MULTI-MONTI® is based on a completely new concept in structural fasteners. By threading the fixing into the substrate material, the thread undercuts and thus enables a positive and safe threaded anchorage like that of an undercut anchor. The threaded anchorage is not subject to any expansion pressure and fixed without preload in the base material.

The quality of the drilled hole is the critical factor for an easy setting of the wall-anchor MULTI-MONTI®. Please ensure that the holes are drilled perpendicular to the fixing plane and that they are sufficiently deep. The drill dust has to be taken out.

In concrete you should use hammer drills according to DIN 8035 and percussion drills in brickwork.

The minimum depths for setting the MULTI-MONTI® are to be found in the following tables. For adjusting and leveling, deeper settings are possible. All necessary technical data is to be found in the following tables.

Because of the undercutting of the threads, the anchorage is guaranteed without retaining force. It is therefore not necessary, unlike other anchoring and plug systems, to apply high torques for a reliable fixing. The preload to be applied serves only the fastening of the component to be fixed. In order to avoid an overload of the anchorage, the manufacturer recommends adherence to the recommended tightening torques, given in T_{inst} .

For fixings with hexagon head screws, type MMS-S/HMS-S, and with panhead screws, type MMS-P/HMS-P, you can use commercially available plain washers according to DIN 9021 or DIN 440.

The min. anchor length has to be calculated by addition of the clamping strength and the embedment. In case, there is no MULTI-MONTI®-screw-in-anchor available in the requested length, the next longer anchor has to be taken. In this case, drilling-depth and embedment will increase.

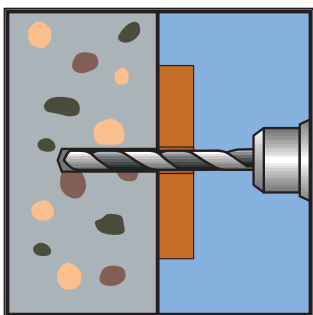

Drilling

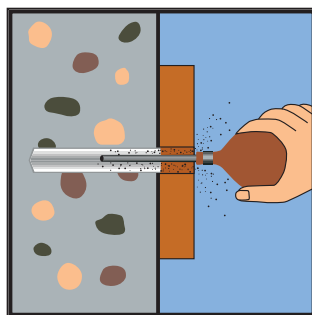

Cleaning

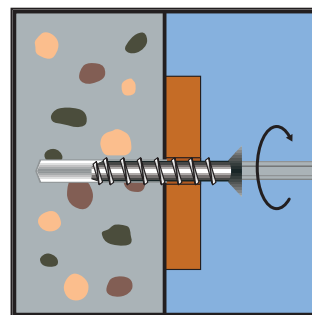

Screwing

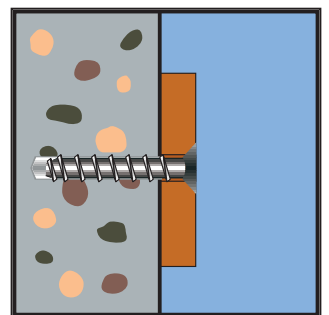

Finished

Technical Manual

HECO-MULTI-MONTI®

Chapter 1

Admissible loads in concrete



1.1 Maximum admissible loads for anchorages with single anchors in cracked and non-cracked concrete according to ETA 05/0010 and ETA 05/0011
(The complete approval needs to be taken into account when calculating loads)

anchor-size	MMS-7,5		MMS-10		MMS-12		MMS-14	MMS-16		
	A4	galv.	A4	galv.	A4	galv.	galv.	galv.		
approval-no. ETA 05/	0011	0010	0011	0010	0011	0010	0010	0010		
max. admissible tension load¹⁾ "N_{zul}" of a single anchor without edge influence¹⁾										
cracked concrete C20/25 ³⁾	[kN]	1,8	2,0	3,7	4,9	8,2	12,1			
non-cracked concrete C20/25 ³⁾	[kN]	2,6	3,1	4,9	6,5	12,3	16,4			
max. admissible shear load²⁾ "V_{zul}" of a single anchor without edge influence²⁾										
cracked concrete C20/25 ³⁾	[kN]	4,5	3,4 ⁵⁾	9,8 ⁵⁾	7,9 ⁵⁾	14,3	11,3 ⁵⁾	24,2 ⁵⁾		
non-cracked concrete C20/25 ³⁾	[kN]	6,0 ⁵⁾	3,4 ⁵⁾	9,8 ⁵⁾	7,9 ⁵⁾	16,2 ⁵⁾	11,3 ⁵⁾	24,2 ⁵⁾		
admissible bending load³⁾ "M_{zul}"										
	[Nm]	10,9	9,4	22,2	18,7	45,9	35	65,1	107,1	
dimensions of the concrete member and installation data										
nominal drill diameter	d ₀ =	[mm]	6,0	8,0	10,0	12,0	14,0			
drilling depth	h ₁ ≥	[mm]	75	65	90	75	100	85	105	130
embedment overall	h _{nom} ≥	[mm]	65	55	75	65	90	75	95	115
calculating embedment	h _{ef} =	[mm]	40		47,5		54,5		71,5	87,5
min. spacing	s _{min} =	[mm]	40		50		60		90	100
min. edge distance	c _{min} =	[mm]	40		50		60		90	100
min. thickness of the concrete member	h _{min} =	[mm]	105	100	130	115	140	125	150	180
clearance through-hole diameter	d _f ≤	[mm]	9		12		14		16	18
recommended tightening torque ⁴⁾	T _{inst} =	[Nm]	20		40		55		90	110

1) that means $c \geq 1,5 \cdot h_{ef}$ and $s \geq 3 \cdot h_{ef}$

2) that means $c \geq 10 \cdot h_{ef}$

3) concrete with normal reinforcement. In case of higher concrete strength higher loads may be possible

4) the tightening torque is not fixed in the approvals and therefore not relevant for the observance of the admission

5) steel failure decisive

*) based on the partial safety factors of anchor resistance acc. approvals and a partial safety factor of the action $\gamma_G = 1,35$. In case of combined loading, anchor-groups as well as edge and spacing influences please see the instructions for the calculation method A in attachment C of the ETAG or following chapters of the calculation help.

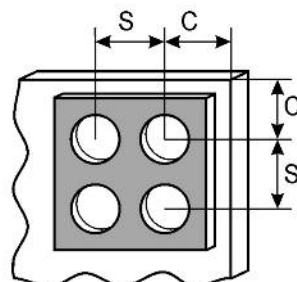
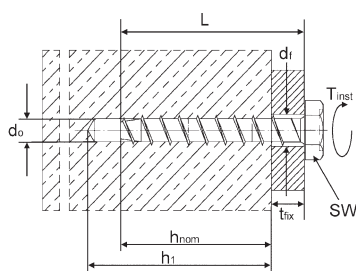



1.2 Admissible loads for fixations in non-cracked concrete and for fixations of lightweight systems with MULTI-MONTI®-Screw-In-Anchors
(The complete approval needs to be taken into account when calculating loads)

anchor-size			MMS-6	MMS-7,5		MMS-7,5	MMS-10
			galv.	A4	galv.	galv.	galv.
approval-no. Z-21.1-			1503	1697	1503	1503	1503
admissible loads of single anchors for tension, shear and combined loads in uncracked concrete C20/25							
admissible load F_{zul} in concrete \geq C20/25	[kN]		1,5	2,0	3,0		-
admissible bending load of single anchors							
admissible bending load M_{zul}	[Nm]		5,1	5,4	10,0	10,0	-
dimensions of the concrete member and installation data							
spacing	$s \geq$	[mm]	160	160	200		-
edge distance	$c \geq$	[mm]	80	80	80		-
width of concrete member	$b \geq$	[mm]	160	160	160		-
reduction factor of the adm. load in case of reinforcement with spacing smaller than 15 cm in the fixation area	[-]		0,7	0,7	0,7		-
admissible loads of single anchors for the fixation of lightweight systems							
admissible load F_{zul} for fixations of lightweight systems acc. DIN 18168 in concrete \geq C20/25	[kN]		0,3	0,5	0,8		0,8
admissible loads for single anchors in case of fire prevention requests							
admissible load F120 in case of fire influences	[kN]		0,3	0,5	0,5		0,8
dimensions of the concrete member and installation data							
nominal drill diameter	$d_0 =$	[mm]	5,0	6,0	6,0		8,0
drilling depth	$h_1 \geq$	[mm]	55	65	55	65	65
embedment overall	$h_{nom} \geq$	[mm]	45	55	45	55	55
spacing	$s =$	[mm]	200				
edge distance	$c =$	[mm]	100				
min. thickness of the concrete member	$h_{min} =$	[mm]	$h_1 + 50$ mm				
clearance-through-hole diameter	$d_f \leq$	[mm]	6,5	8	8		10,5
recommended tightening torque ⁴⁾	$T_{inst} =$	[Nm]	12	20	20		50

4) the tightening torque is not fixed in the approvals

Technical Manual

HECO-MULTI-MONTI®

Chapter 2

Recommended loads for fixations in concrete and masonry for HMS-5 to MMS-20

2.1 recommended loads for fixations in cracked and non-cracked concrete with MULTI-MONTI®-Screw-In-Anchors HMS-5 to MMS-20

anchor-size		HMS-5	MMS-6	MMS-7,5		MMS-10		MMS-12		MMS-14	MMS-16	MMS-20	
		galv.	galv.	A4	galv.	A4	galv.	A4	galv.	galv.	galv.	galv.	
max. recommended tension load "N" of a single anchor without edge influence¹⁾													
non-cracked concrete C20/25 ³⁾	[kN]	2,6	3,8	5,3	6,8	8,3	12,5	17,0	18,3				
cracked concrete C20/25 ³⁾	[kN]	1,8	2,7	3,8	4,9	6,0	9,0	12,1	13,1				
max. recommended shear load "V" of a single anchor without edge influence²⁾													
non-cracked concrete C20/25 ³⁾	[kN]	2,0	3,1	6,0	3,4	9,9	7,9	14,3	11,3	17,8	24,2	40,0	
cracked concrete C20/25 ³⁾	[kN]	2,0	3,1	4,5	3,4	9,9	7,9	16,2	11,3	17,8	24,2	31,4	
recommended bending load "M" of a single anchor													
	[Nm]	-	5,1	10,9	9,4	22,2	18,7	45,9	35,0	65,0	107,0	-	
dimensions of the concrete member and installation data													
nominal drill diameter	d_0 =	[mm]	4	5	6	8	10	12	14	18			
drilling depth	h_1 ≥	[mm]	$h_{nom} + d_0$										
embedment overall	h_{nom} ≥	[mm]	35	45	65	55	75	65	90	75	95	115	115
calculating embedment	h_{ef} =	[mm]	25	32	40	48	55	72	88	92			
min. edge distance	c_{min} =	[mm]	35	40	40	50	60	80	80	80			
min. spacing	s_{min} =	[mm]	35	40	40	50	60	80	80	80			
min. thickness of the concrete member	h_{min} =	[mm]	80	90	100	120	130	150	180	220			
clearance through-hole diameter	d_f ≤	[mm]	6,0	7,0	8,5	12,0	14,0	16,0	18,0	22,0			
recommended tightening torque	T_{inst} =	[Nm]	8	12	20	50	80	100	150	180			

1) that means $c \geq 1,5 \cdot h_{ef}$ and $s \geq 3 \cdot h_{ef}$

2) that means $c \geq 10 \cdot h_{ef}$

3) concrete with normal reinforcement

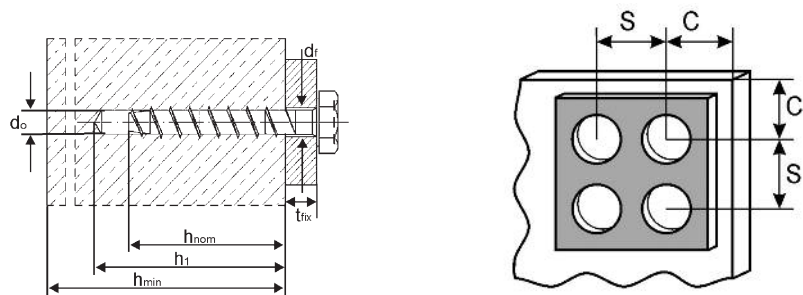

2.2 recommended loads for fixations in brickwork with
MULTI-MONTI®-Screw-In-Anchors HMS-5 to MMS-12

anchor-size		strength	HMS-5	MMS-6	MMS-7,5	MMS-10	MMS-12	MMS-14	MMS-16	MMS-20		
			galv.	galv.	galv.	galv.	galv.	galv.	galv.	galv.		
max. recommended tension load of a single anchor without edge influence ¹⁾ in sand-lime-brick												
recommended tension load "N" in sand-lime-brick	[kN]	KS 12	0,5	1,1	1,4	2,1	2,5	-	-	-		
max. recommended tension load of a single anchor without edge influence ¹⁾ in full-brick												
recommended tension load "N" in full-brick	[kN]	MZ 12	0,3	0,5	0,8	1,0	1,2	-	-	-		
max. recommended tension load of a single anchor without edge influence ¹⁾ in clinker												
recommended tension load "N" in clinker	[kN]	KS 12	0,5	1,1	1,4	2,1	2,5	-	-	-		
dimensions of the brickwork member and installation data												
nominal drill diameter ²⁾	d_0	=	[mm]	4	5	6	8	10	-	-	-	
drilling depth	h_1	≥	[mm]	$h_{nom} + d_0$								
embedment overall	h_{nom}	≥	[mm]	35	45	55	65	75	-	-	-	
calculating embedment	h_{ef}	=	[mm]	25	32	40	48	55	-	-	-	
min. edge distance	c_{min}	=	[mm]	35	40	50	50	60	-	-	-	
min. spacing	s_{min}	=	[mm]	35	40	50	50	60	-	-	-	
min. thickness of the brickwork	h_{min}	=	[mm]	80	90	100	120	130	-	-	-	
clearance through-hole diameter	d_f	≤	[mm]	6,0	7,0	8,5	12,0	14,0	-	-	-	
recommended tightening torque	T_{inst}	=	[Nm]	3	6	15	30	30	-	-	-	

1) edge distance to the wall $c \geq 1,5 \cdot h_{ef}$

2) percussion drill

2.3 recommended loads for fire prevention F-30 to F-120 in concrete and
brickwork for MULTI-MONTI®-Screw-In-Anchors HMS-5 to MMS-12

anchor-size			HMS-5	MMS-6	MMS-7,5	MMS-10	MMS-12	MMS-14	MMS-16	MMS-20
rec. load for tensile, shear and oblique loads fore fire prevention fixations in concrete										
load in case of fire prevention requestions in concrete $\geq C20/25$	[kN]	F 30	0,5	0,9	1,5	2,7	4,4	-	-	-
		F 60	0,3	0,6	1,1	2,0	3,2	-	-	-
		F 90	0,25	0,4	0,8	1,5	2,4	-	-	-
		F 120	0,1	0,3	0,5	1,0	1,5	-	-	-
rec. load for tensile, shear and oblique loads fore fire prevention fixations in brickwork										
load in case of fire prevention requestions in brickwork ¹⁾	[kN]	F 30	0,5	0,8	1,25	2,5	3,7	-	-	-
		F 60	0,3	0,5	0,8	1,4	2,2	-	-	-
		F 90	0,15	0,35	0,5	1,0	1,5	-	-	-
		F 120	0,1	0,3	0,3	0,8	1,3	-	-	-

1) consider the load-recommendations of chapter 2.2

Technical Manual

HECO-MULTI-MONTI®

Chapter 3 Products

3.1 MMS-S

Type : MULTI-MONTI®-Screw-In-Anchor with hexagon head

Material : steel

Surface : bright zinc plated

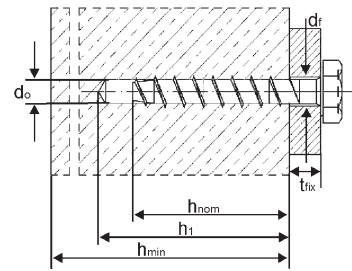

erfüllt die Anforderungen nach VoS CEA 4001



Option 1 für gerissenen und ungerissenen Beton



type	size		spanner size	head-diameter	drill-diameter d ₀	drill depth h ₁	embedment h _{nom}	clamping strength t _{fix}	adm. tension load in cracked concrete C20/25	adm. tension load in non-cracked concrete C20/25	rec. tension load in non-cracked concrete C20/25
	D	L							[kN]	[kN]	[kN]
	[mm]	[mm]		[mm]	[mm]	[mm]	[mm]	[mm]			
HMS-S ¹⁾	6	x 40	SW 10	-	5	45	35	5	-	-	2,4
MMS-S	6	x 50	SW 10	-	5	55	45	5	0,3 ²⁾	1,5 ²⁾	3,8
MMS-S	6	x 60	SW 10	-	5	55	45	15	0,3 ²⁾	1,5 ²⁾	3,8
MMS-S	6	x 80	SW 10	-	5	55	45	35	0,3 ²⁾	1,5 ²⁾	3,8
MMS-S	6	x 100	SW 10	-	5	55	45	55	0,3 ²⁾	1,5 ²⁾	3,8
HMS-S ¹⁾	7,5	x 35	SW 13	-	6	40	35	1	-	-	2,2
HMS-S ¹⁾	7,5	x 40	SW 13	-	6	45	35	5	-	-	2,2
MMS-S	7,5	x 45	SW 13	-	6	55	45	1	0,5 ²⁾	2,0 ²⁾	3,7
MMS-S	7,5	x 50	SW 13	-	6	55	45	5	0,5 ²⁾	2,0 ²⁾	3,7
MMS-S	7,5	x 60	SW 13	-	6	65	55	5	2,0 ⁷⁾	3,1 ⁷⁾	5,3
MMS-S	7,5	x 80	SW 13	-	6	65	55	25	2,0 ⁷⁾	3,1 ⁷⁾	5,3
MMS-S	7,5	x 100	SW 13	-	6	65	55	45	2,0 ⁷⁾	3,1 ⁷⁾	5,3
MMS-S	7,5	x 120	SW 13	-	6	65	55	65	2,0 ⁷⁾	3,1 ⁷⁾	5,3
MMS-S	7,5	x 140	SW 13	-	6	65	55	85	2,0 ⁷⁾	3,1 ⁷⁾	5,3
MMS-S	10	x 60	SW 16	-	8	65	55	5	0,8 ²⁾	-	5,0
MMS-S	10	x 70	SW 16	-	8	75	65	5	3,7 ⁷⁾	4,9 ⁷⁾	6,8
MMS-S	10	x 80	SW 16	-	8	75	65	15	3,7 ⁷⁾	4,9 ⁷⁾	6,8
MMS-S	10	x 100	SW 16	-	8	75	65	35	3,7 ⁷⁾	4,9 ⁷⁾	6,8
MMS-S	10	x 120	SW 16	-	8	75	65	55	3,7 ⁷⁾	4,9 ⁷⁾	6,8
MMS-S	10	x 140	SW 16	-	8	75	65	75	3,7 ⁷⁾	4,9 ⁷⁾	6,8
MMS-S	10	x 160	SW 16	-	8	75	65	95	3,7 ⁷⁾	4,9 ⁷⁾	6,8
HMS-S ¹⁾	12	x 60	SW 18	-	10	65	55	5	-	-	4,7
MMS-S	12	x 80	SW 18	-	10	85	75	5	4,9 ⁷⁾	6,5 ⁷⁾	8,3
MMS-S	12	x 90	SW 18	-	10	85	75	15	4,9 ⁷⁾	6,5 ⁷⁾	8,3
MMS-S	12	x 100	SW 18	-	10	85	75	25	4,9 ⁷⁾	6,5 ⁷⁾	8,3
MMS-S	12	x 120	SW 18	-	10	85	75	45	4,9 ⁷⁾	6,5 ⁷⁾	8,3
MMS-S	12	x 140	SW 18	-	10	85	75	65	4,9 ⁷⁾	6,5 ⁷⁾	8,3
MMS-S	12	x 160	SW 18	-	10	85	75	85	4,9 ⁷⁾	6,5 ⁷⁾	8,3
MMS-S ^{*)}	14	x 80	SW 21	-	12	80	70	10	-	-	7,3
MMS-S	14	x 110	SW 21	-	12	105	95	15	8,2 ⁷⁾	12,3 ⁷⁾	12,5
MMS-S	14	x 130	SW 21	-	12	105	95	35	8,2 ⁷⁾	12,3 ⁷⁾	12,5
MMS-S	14	x 150	SW 21	-	12	105	95	55	8,2 ⁷⁾	12,3 ⁷⁾	12,5
MMS-S ¹⁾	16	x 80	SW 24	-	14	80	70	10	-	-	7,3
MMS-S ¹⁾	16	x 120	SW 24	-	14	130	110	10	-	-	15,9
MMS-S	16	x 130	SW 24	-	14	130	115	15	12,1 ⁷⁾	16,4 ⁷⁾	17,0
MMS-S	16	x 150	SW 24	-	14	130	115	35	12,1 ⁷⁾	16,4 ⁷⁾	17,0
MMS-S ¹⁾	20	x 100	SW 30	-	18	110	90	10	-	-	10,5
MMS-S ¹⁾	20	x 130	SW 30	-	18	140	115	15	-	-	18,3

1) = not part of the approvals
7) = according to ETA 05/0010

2) = according to DIBt-approval no. Z-21.1-1503
*) = on request

3.2 MMS-S

Type : MULTI-MONTI®-Screw-In-Anchor with hexagon head
incl. washers acc. DIN 440 (diameter 43 mm)

Material : steel

Surface : bright zinc plated

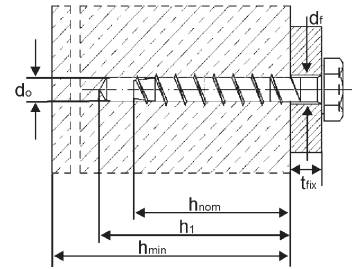
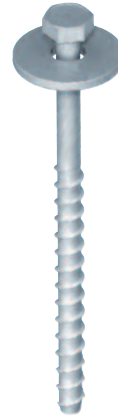

type	size D x L		spanner size	head- diameter	drill- diameter d ₀	drill depth h ₁	em- bedment h _{nom}	clamping strength t _{fix}	adm. tension load in cracked concrete C20/25	adm. tension load in non- cracked concrete C20/25	rec. tension load in non- cracked concrete C20/25
	[mm]	[mm]							[kN]	[kN]	[kN]
MMS-S	12	x 180	SW 18	-	10	85	75	105	4,9 ⁷⁾	6,5 ⁷⁾	8,3
MMS-S	12	x 200	SW 18	-	10	85	75	125	4,9 ⁷⁾	6,5 ⁷⁾	8,3
MMS-S	12	x 240	SW 18	-	10	85	75	165	4,9 ⁷⁾	6,5 ⁷⁾	8,3
MMS-S	12	x 280	SW 18	-	10	85	75	205	4,9 ⁷⁾	6,5 ⁷⁾	8,3
MMS-S	12	x 320	SW 18	-	10	85	75	245	4,9 ⁷⁾	6,5 ⁷⁾	8,3

7) = according to ETA 05/0010

3.3 MMS-SS

Type : MULTI-MONTI®-Screw-In-Anchor with hexagon head
and combined washer

Material : steel

Surface : bright zinc plated

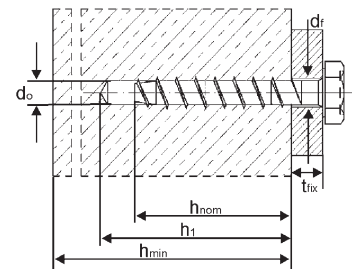
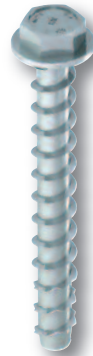

type	size D x L		spanner size	washer- diameter	drill- diameter d ₀	drill depth h ₁	em- bedment h _{nom}	clamping strength t _{fix}	adm. tension load in cracked concrete C20/25	adm. tension load in non- cracked concrete C20/25	rec. tension load in non- cracked concrete C20/25
	[mm]	[mm]							[kN]	[kN]	[kN]
MMS-SS	6	x 50	SW 8	11,5	5	55	45	5	0,3 ²⁾	1,5 ²⁾	3,8
MMS-SS	6	x 60	SW 8	11,5	5	55	45	15	0,3 ²⁾	1,5 ²⁾	3,8
MMS-SS	7,5	x 50	SW 10	14,5	6	55	45	5	0,5 ²⁾	2,0 ²⁾	3,7
MMS-SS	7,5	x 60	SW 10	14,5	6	65	55	5	2,0 ⁷⁾	3,1 ⁷⁾	5,3
MMS-SS	10	x 70	SW 13	19	8	75	65	5	3,7 ⁷⁾	4,9 ⁷⁾	6,8
MMS-SS	10	x 80	SW 13	19	8	75	65	15	3,7 ⁷⁾	4,9 ⁷⁾	6,8
MMS-SS	12	x 90	SW 15	22,5	10	85	75	15	4,9 ⁷⁾	6,5 ⁷⁾	8,3
MMS-SS	12	x 100	SW 15	22,5	10	85	75	25	4,9 ⁷⁾	6,5 ⁷⁾	8,3

2) = according to DIBt-approval no. Z-21.1-1503

7) = according to ETA 05/0010

Technical Manual

HECO-MULTI-MONTI®

3.4 MMS-S stainless steel A4

Type : MULTI-MONTI®-Screw-In-Anchor with hexagon head

Material : stainless steel A4 1.4401
other Steel-sorts on request

Surface : stainless steel self-colour
function tip phosphated

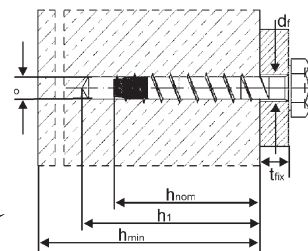

type	size D x L		spanner size	drill- diameter d ₀	drill depth h ₁	em- bedment h _{nom}	clamping strength t _{fix}	adm. tension load in cracked con- crete C20/25	adm. tension load in non- cracked con- crete C20/25	rec. tension load in non- cracked con- crete C20/25
	[mm]	[mm]						[kN]	[kN]	[kN]
MMS-S	7,5	50/65	SW 13	6	65	55	10	0,5 ⁵⁾	2,0 ⁵⁾	3,7
MMS-S	7,5	75/10	SW 13	6	75	65	10	1,8 ⁷⁾	2,6 ⁷⁾	5,3
MMS-S	10	85/10	SW 16	8	90	75	10	3,7 ⁷⁾	4,9 ⁷⁾	6,8
MMS-S	10	95/20	SW 16	8	90	75	20	3,7 ⁷⁾	4,9 ⁷⁾	6,8
MMS-S	12	100/10	SW 18	10	100	90	10	4,9 ⁷⁾	6,5 ⁷⁾	8,3
MMS-S	12	120/30	SW 18	10	100	90	30	4,9 ⁷⁾	6,5 ⁷⁾	8,3

5) = according to DIBt-approval no. Z-21.1-1697

7) = according to ETA 05/0011

3.5 MMS-St

Type : MULTI-MONTI®-Screw-In-Anchor with metric stud

Material : steel

Surface : bright zinc plated

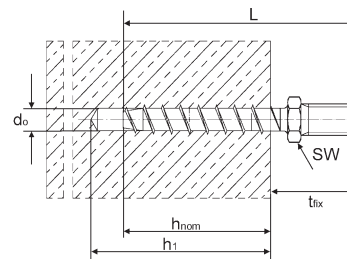
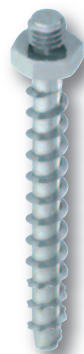

type	size D x L		spanner size	joint thread	drill- diameter d ₀	drill depth h ₁	em- bedment h _{nom}	clamping strength t _{fix}	adm. tension load in cracked con- crete C20/25	adm. tension load in non- cracked con- crete C20/25	rec. tension load in non- cracked con- crete C20/25
	[mm]	[mm]							[kN]	[kN]	[kN]
MMS-St	6	60	SW 10	M 6 * 5	5	55	45	15	0,3 ²⁾	1,5 ²⁾	3,8
MMS-St	7,5	70	SW 10	M 8 * 14	6	55	45	25	0,5 ²⁾	2,0 ²⁾	3,7
MMS-St	7,5	80	SW 10	M 8 * 14	6	65	55	25	2,0 ⁷⁾	3,1 ⁷⁾	5,3
MMS-St	7,5	100	SW 10	M 8 * 14	6	65	55	45	2,0 ⁷⁾	3,1 ⁷⁾	5,3
MMS-St	7,5	120	SW 10	M 8 * 14	6	65	55	65	2,0 ⁷⁾	3,1 ⁷⁾	5,3
MMS-St	7,5	140	SW 10	M 8 * 14	6	65	55	85	2,0 ⁷⁾	3,1 ⁷⁾	5,3
MMS-St	7,5	160	SW 10	M 8 * 14	6	65	55	105	2,0 ⁷⁾	3,1 ⁷⁾	5,3
MMS-St	10	80	SW 13	M 10 * 11	8	65	55	25	0,8 ²⁾	-	5,0
MMS-St	10	100	SW 13	M 10 * 11	8	75	65	35	3,7 ⁷⁾	4,9 ⁷⁾	6,8
MMS-St	10	120	SW 13	M 10 * 11	8	75	65	55	3,7 ⁷⁾	4,9 ⁷⁾	6,8
MMS-St	10	140	SW 13	M 10 * 11	8	75	65	75	3,7 ⁷⁾	4,9 ⁷⁾	6,8
MMS-St	10	160	SW 13	M 10 * 11	8	75	65	95	3,7 ⁷⁾	4,9 ⁷⁾	6,8

2) = according to DIBt-approval no. Z-21.1-1503

7) = according to ETA 05/0010

3.6 MMS-I

Type : MULTI-MONTI®-Screw-In-Anchor with internal metric stud M8 or M10 respectively combined internal thread M8 / M10

Material : steel

Surface : bright zinc plated

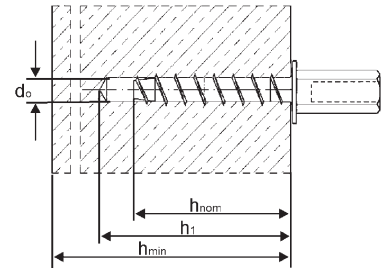

type	size D x L		spanner size	internal metric stud	drill- diameter d ₀	drill depth h ₁	em- bedment h _{nom}	clamping strength t _{fix}	adm. tension load in cracked con- crete C20/25	adm. tension load in non- cracked con- crete C20/25	rec. tension load in non- cracked con- crete C20/25
	[mm]	[mm]							[kN]	[kN]	[kN]
MMS-I ⁷⁾	7,5	60	SW 13	M8 / M10	6	65	55	-	2,0 ⁷⁾	3,1 ⁷⁾	5,3
MMS-I	7,5	60	SW 13	M8 * 10	6	65	55	-	2,0 ⁷⁾	3,1 ⁷⁾	5,3
MMS-I	10	85	SW 13	M10 * 12	8	75	65	-	3,7 ⁷⁾	4,9 ⁷⁾	6,8

7) = according to ETA 05/0010

*) = not compliant to VDS CEA 4001 combined internal thread M8 * 10/M10 * 12

3.7 MMS-P

Type : MULTI-MONTI®-Screw-In-Anchor with pan head

Material : steel

Surface : bright zinc plated

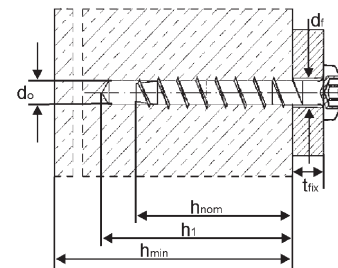

type	size D x L		re- cess	head- diameter	drill- diameter d ₀	drill depth h ₁	em- bedment h _{nom}	clamping strength t _{fix}	adm. tension load in cracked con- crete C20/25	adm. tension load in non- cracked con- crete C20/25	rec. tension load in non- cracked con- crete C20/25
	[mm]	[mm]							[kN]	[kN]	[kN]
HMS-P ¹⁾	5	30	T-20	7,9	4	35	30	1	-	-	1,9
HMS-P ¹⁾	5	50	T-20	7,9	4	40	35	15	-	-	2,6
HMS-P ¹⁾	6	30	T-30	11,6	5	35	30	1	-	-	1,9
HMS-P ¹⁾	6	40	T-30	11,6	5	40	35	5	-	-	2,4
MMS-P	6	50	T-30	11,6	5	55	45	5	0,3 ²⁾	1,5 ²⁾	3,8
MMS-P	6	60	T-30	11,6	5	55	45	15	0,3 ²⁾	1,5 ²⁾	3,8
MMS-P	6	80	T-30	11,6	5	55	45	35	0,3 ²⁾	1,5 ²⁾	3,8
HMS-P ¹⁾	7,5	25	T-40	13,6	6	30	25	1	-	-	1,2
MMS-P	7,5	45	T-40	13,6	6	55	45	1	0,5 ²⁾	2,0 ²⁾	3,7
MMS-P	7,5	50	T-40	13,6	6	55	45	5	0,5 ²⁾	2,0 ²⁾	3,7
MMS-P	7,5	70	T-40	13,6	6	65	55	15	2,0 ⁷⁾	3,1 ⁷⁾	5,3
MMS-P	10	70	T-40	17	8	75	65	5	3,7 ⁷⁾	4,9 ⁷⁾	6,8

1) = not part of the approvals

2) = according to DIBt-approval no. Z-21.1-1503

7) = according to ETA 05/0010

Technical Manual

HECO-MULTI-MONTI®

3.8 MMS-P stainless steel A5

Type : MULTI-MONTI®-Screw-In-Anchor with pan head

Material : stainless steel A5 1.4571
other Steel-sorts on request

Surface : stainless steel self-colour
function tip phosphated

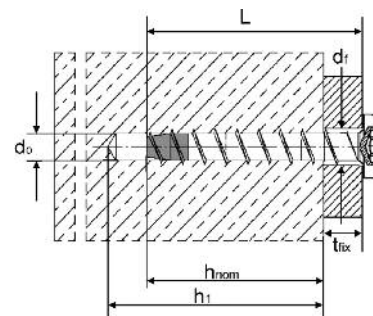

type	size D x L		re- cess	head- diameter	drill- diameter d ₀	drill depth h ₁	em- bedment h _{nom}	clamping strength t _{fix}	adm. tension load in cracked concrete C20/25	adm. tension load in non- cracked concrete C20/25	rec. tension load in non- cracked concrete C20/25
	[mm]	[mm]							[kN]	[kN]	[kN]
MMS-P	7,5	75/10	T-30	13,6	6	75	65	10	1,8 ⁷⁾	2,6 ⁷⁾	5,3
MMS-P	7,5	85/20	T-30	13,6	6	75	65	20	1,8 ⁷⁾	2,6 ⁷⁾	5,3
MMS-P	7,5	95/30	T-30	13,6	6	75	65	30	1,8 ⁷⁾	2,6 ⁷⁾	5,3
MMS-P	7,5	115/50	T-30	13,6	6	75	65	50	1,8 ⁷⁾	2,6 ⁷⁾	5,3

7) = according to ETA 05/0011

3.9 MMS-MS

Type : MULTI-MONTI®-Screw-In-Anchor with flat pan head

Material : steel

Surface : bright zinc plated

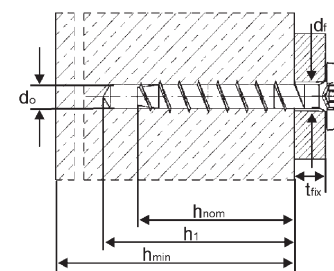

type	size D x L		re- cess	head- diameter	drill- diameter d ₀	drill depth h ₁	em- bedment h _{nom}	clamping strength t _{fix}	adm. tension load in cracked concrete C20/25	adm. tension load in non- cracked concrete C20/25	rec. tension load in non- cracked concrete C20/25
	[mm]	[mm]							[kN]	[kN]	[kN]
MMS-MS	7,5	45	T-30	17	6	55	45	0	0,5 ²⁾	2,0 ²⁾	3,7
MMS-MS	7,5	50	T-30	17	6	55	45	5	0,5 ²⁾	2,0 ²⁾	3,7
MMS-MS	7,5	60	T-30	14,5	6	65	55	5	2,0 ⁷⁾	3,1 ⁷⁾	5,3

2) = according to DIBt-approval no. Z-21.1-1503

7) = according to ETA 05/0010

3.10 MMS-F

Type : MULTI-MONTI®-Screw-In-Anchor with countersunk 90°

Material : steel

Surface : bright zinc plated

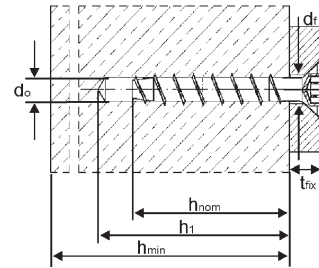
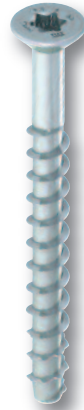

erfüllt die Anforderungen nach VoS CEA 4001



Option 1 für gerissenen und ungerissenen Beton



Feuerwiderstandsklasse F120

type	size D x L		re- cess	head- diameter	drill- diameter d ₀	drill depth h ₁	em- bedment h _{nom}	clamping strength t _{fix}	adm. tension	adm. tension	rec. tension
	[mm]	[mm]							load in cracked con- crete C20/25	load in non- cracked con- crete C20/25	load in non- cracked con- crete C20/25
								[kN]	[kN]	[kN]	
HMS-F ¹⁾	5	x 30	T-25	8,7	4	35	30	1	-	-	1,9
HMS-F ¹⁾	5	x 40	T-25	8,7	4	40	35	5	-	-	2,6
HMS-F ¹⁾	5	x 50	T-25	8,7	4	40	35	15	-	-	2,6
HMS-F ¹⁾	5	x 60	T-25	8,7	4	40	35	25	-	-	2,6
HMS-F ¹⁾	6	x 40	T-30	11	5	35	30	10	-	-	1,9
MMS-F	6	x 50	T-30	11	5	55	45	5	0,3 ²⁾	1,5 ²⁾	3,8
MMS-F	6	x 60	T-30	11	5	55	45	15	0,3 ²⁾	1,5 ²⁾	3,8
MMS-F	6	x 80	T-30	11	5	55	45	35	0,3 ²⁾	1,5 ²⁾	3,8
MMS-F	6	x 100	T-30	11	5	55	45	55	0,3 ²⁾	1,5 ²⁾	3,8
MMS-F	6	x 120	T-30	11	5	55	45	75	0,3 ²⁾	1,5 ²⁾	3,8
MMS-F	6	x 140	T-30	11	5	55	45	95	0,3 ²⁾	1,5 ²⁾	3,8
MMS-F	7,5	x 50	T-40	13,6	6	55	45	5	0,5 ²⁾	2,0 ²⁾	3,7
MMS-F	7,5	x 60	T-40	13,6	6	65	55	5	2,0 ⁷⁾	3,1 ⁷⁾	5,3
MMS-F	7,5	x 80	T-40	13,6	6	65	55	25	2,0 ²⁾	3,1 ⁷⁾	5,3
MMS-F	7,5	x 100	T-40	13,6	6	65	55	45	2,0 ²⁾	3,1 ⁷⁾	5,3
MMS-F	7,5	x 120	T-40	13,6	6	65	55	65	2,0 ²⁾	3,1 ⁷⁾	5,3
MMS-F	7,5	x 140	T-40	13,6	6	65	55	85	2,0 ²⁾	3,1 ⁷⁾	5,3
MMS-F	7,5	x 160	T-40	13,6	6	65	55	105	2,0 ²⁾	3,1 ⁷⁾	5,3
MMS-F	10	x 80	T-40	17	8	75	65	15	3,7 ⁷⁾	4,9 ⁷⁾	6,8

1) = not part of the approvals

2) = according to DIBt-approval no. Z-21.1-1503

7) = according to ETA 05/0010

Technical Manual

HECO-MULTI-MONTI®

3.11 MMS-F stainless steel A5

Type : MULTI-MONTI®-Screw-In-Anchor with countersunk 90°

Material : stainless steel A5 1.4571

Surface : stainless steel self-colour
function tip phosphated

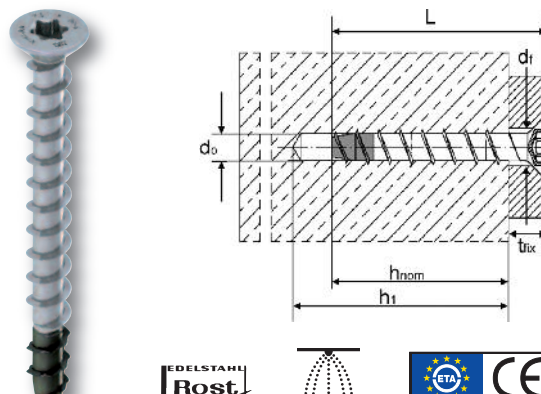

type	size D x L		re- cess	head- diameter	drill- diameter d ₀	drill depth h ₁	em- bedment h _{nom}	clamping strength t _{fix}	adm. tension load in cracked concrete C20/25	adm. tension load in non- cracked concrete C20/25	rec. tension load in non- cracked concrete C20/25
	[mm]	[mm]							[kN]	[kN]	[kN]
MMS-F	7,5	75/10	T-30	13,6	6	75	65	10	1,8 ⁷⁾	2,6 ⁷⁾	5,3
MMS-F	7,5	85/20	T-30	13,6	6	75	65	20	1,8 ⁷⁾	2,6 ⁷⁾	5,3
MMS-F	7,5	95/30	T-30	13,6	6	75	65	30	1,8 ⁷⁾	2,6 ⁷⁾	5,3
MMS-F	7,5	115/50	T-30	13,6	6	75	65	50	1,8 ⁷⁾	2,6 ⁷⁾	5,3

7) = according to ETA 05/0011

3.12 HMS-KS

Type : MULTI-MONTI®-Wall-Screw with small countersunk

Material : steel

Surface : bright zinc plated

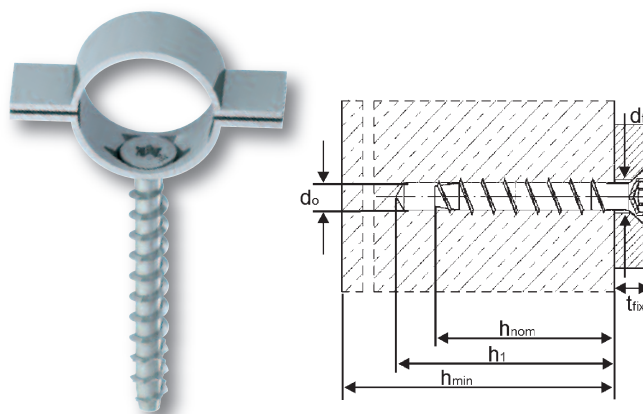

type	size D x L		re- cess	head- diameter	drill- diameter d ₀	drill depth h ₁	em- bedment h _{nom}	clamping strength t _{fix}	adm. tension load in cracked concrete C20/25	adm. tension load in non- cracked concrete C20/25	rec. tension load in non- cracked concrete C20/25
	[mm]	[mm]							[kN]	[kN]	[kN]
HMS-KS ¹⁾	5	40	T-20	7,8	4	40	35	5	-	-	2,6
HMS-KS ¹⁾	5	50	T-20	7,8	4	40	35	15	-	-	2,6

1) = not part of the approvals

3.13 HMS-R

Type : MULTI-MONTI®-Eye-Bolt incl. setting tool

Material : steel

Surface : bright zinc plated

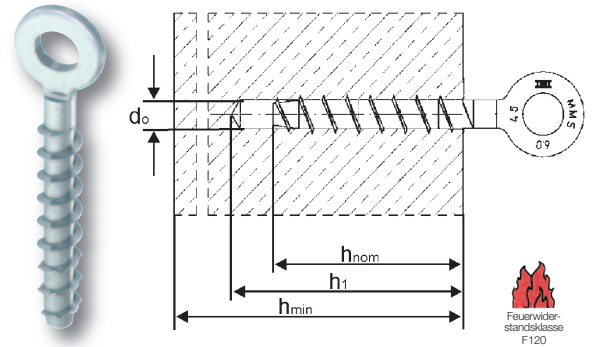

type	size D x L	re- cess	eye- diameter	drill- diameter d ₀	drill depth h ₁	em- bedment h _{nom}	clamping strength t _{fix}	adm. tension load in cracked con- crete C20/25	adm. tension load in non- cracked con- crete C20/25	rec. tension load in non- cracked con- crete C20/25
	[mm] [mm]		[mm]	[mm]	[mm]	[mm]	[mm]	[kN]	[kN]	[kN]
MMS-R ¹⁾	6 x 40	sett. Tool	7	5	50	40	-	-	-	2,4

1) = not part of the approvals

3.14 MMS-TC TimberConnect

Type: MULTI-MONTI®-Screw-In-Anchor with secondary wood-thread

Material: steel

Surface: DP-coated

Setting tools MMS-TC TimberConnect

size	MMS-TC 7,5	MMS-TC 10	MMS-TC 12
setting tool	H 43603-T30	H 43604-T40	H 43605-T50

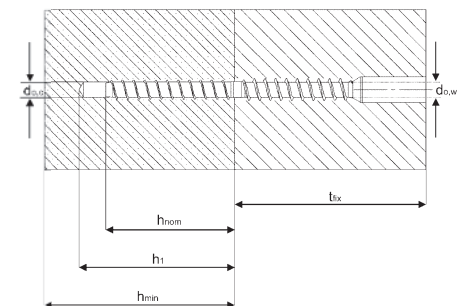

type	size D x L	re- cess	head- diameter	drill- diameter d ₀	drill depth h ₁	em- bedment h _{nom}	clamping strength t _{fix}	adm. tension load in cracked con- crete C20/25	adm. tension load in non- cracked con- crete C20/25	rec. tension load in non- cracked con- crete C20/25
	[mm] [mm]		[mm]	[mm]	[mm]	[mm]	[mm]	[kN]	[kN]	[kN]
MMS-TC	7,5 x 100	T-30	10	6	65	55	≥ 40	1,0 ⁸⁾	1,0 ⁸⁾	-
MMS-TC	10 x 130	T-40	15,5	8	75	65	≥ 60	2,1 ⁸⁾	2,1 ⁸⁾	-
MMS-TC	12 x 160	T-50	17,5	10	85	75	≥ 80	3,3 ⁸⁾	3,3 ⁸⁾	-

8) = according to DIBt-approval no Z-21.1-1879
with: utility class 1; k_{mod} = 0,6; solid wood C 24



HECO-Schrauben GmbH & Co. KG

Dr.-Kurt-Stein-Straße 28 · D-78713 Schramberg
Tel.: +49 (0)74 22 / 9 89-0 · Fax: +49 (0)74 22 / 9 89-200
Mail: info@heco-schrauben.de · www.heco-schrauben.de