

Daikin Altherma high  
temperature split  
Technical Data  
ETVH16E6V7 /  
ETVH16E9W7  
ETVX16E6V7 /  
ETVX16E9W7





# TABLE OF CONTENTS

## ETVX16E6V7 / ETVX16E9W7 / ETVH16E6V7 / ETVH16E9W7

---

1	<b>Features</b>	4
	ETVH16E6V7, ETVH16E9W7	4
	ETVX16E6V7, ETVX16E9W7	5
2	<b>Specifications</b>	6
3	<b>Electrical data</b>	14
4	<b>Combination table</b>	16
5	<b>Capacity tables</b>	17
	Domestic Hot Water performance	17
6	<b>Dimensional drawings</b>	18
7	<b>Centre of gravity</b>	19
8	<b>Piping diagrams</b>	20
9	<b>Wiring diagrams</b>	21
	Notes & Legend	21
	Control Circuit	22
	Power Supply, Back-up Heater	25
10	<b>External connection diagrams</b>	26
11	<b>Installation</b>	27
	Installation Method	27
12	<b>Operation range</b>	28
13	<b>Hydraulic performance</b>	29
	Static Pressure Drop Unit	29

# 1 Features

ETVH16E6V7, ETVH16E9W7

## Floor standing air to water heat pump for heating, cooling and hot water

1

- › A combined stainless steel domestic hot water tank of 180 or 230L and heat pump for easy installation
- › Inclusion of all hydraulic components means no third party components are required
- › The unit's sleek design blends in with other household appliances.
- › Energy efficient heating only system based on air to water heat pump technology
- › Quick configuration in 9 steps in a high resolution colour interface wizard



Onecta app  
(optional)

# 1 Features

ETVX16E6V7, ETVX16E9W7

## Floor standing air to water heat pump for heating, cooling and hot water

- › A combined stainless steel domestic hot water tank of 180 or 230L and heat pump for easy installation
- › Inclusion of all hydraulic components means no third party components are required
- › The unit's sleek design blends in with other household appliances.
- › For hot water, heating and cooling
- › Quick configuration in 9 steps in a high resolution colour interface wizard

1



Onecta app  
(optional)

## 2 Specifications

### Specifications

Technical specifications				ETVH16S18E6V7		ETVH16S23E6V7		
Heater capacity	Step 1		kW			2		
	Step 2		kW			2 or 4		
Power input	Nom.		kW			0.21		
Casing	Material			Precoated sheet metal				
Dimensions	Unit	Height	mm	1,650		1,850		
		Width	mm			595		
		Depth	mm			625		
	Packed unit	Height	mm	1,820		2,020		
		Width	mm			720		
		Depth	mm			740		
Weight	Unit		kg	109		118		
	Packed unit		kg	126		135		
Packing	Material			Wood / Carton / PE wrapping foil / Metal				
	Weight			kg				
Pump	Type			Grundfos UPMXL GEO 25-125 130 PWM				
	Nr of speeds			PWM				
	Power input			W				
				179				
Water side Heat exchanger	Water flow rate	Min.	l/min	20.0 (1)				
Expansion vessel	Volume			l				
	Max. water pressure			bar				
	Pre pressure			bar				
Tank	Name			Stainless steel domestic hot water tank 180 l		Stainless steel domestic hot water tank 230 L		
	Water volume			l		180		
	Material			Stainless steel (EN 1.4521)				
	Maximum water temperature			°C				
				70.0				
	Maximum water pressure			bar				
				10				
	Insulation	Material			Polyurethane foam			
		Heat loss		kWh/24h	1.2 (2)		1.4 (2)	
	Standing heat loss	S		W	50		58	
		V		l	180		220	
	Corrosion protection			Pickling				
	Energy efficiency class			B				
General	Supplier/	Name or trademark		Daikin Europe N.V.				
	Manu- facturer details	Name and address		Daikin Europe N.V. - Zandvoordestraat 300, 8400 Oostende, Belgium				
3-way valve	Coefficient of	Space heating	m <sup>3</sup> /h	8				
		Domestic hot water tank flow (kV)	m <sup>3</sup> /h	10				
Water circuit	Piping connections diameter			inch				
	Piping material			G 1" (female)				
	Internal piping diameter			inch				
				1-1/4"				
	Piping			inch				
				1"				
	Safety valve			bar				
				3				
	Manometer			Digital				
	Drain valve / fill valve			No				
	Shut off valve			Yes				
	flowswitch			Yes				
	Air purge valve			Yes				
	Total water volume			l				
	Minimum water volume in the system for cooling			l				
Minimum water volume in the system for heating			l					
Water circuit - Domestic hot water side	Piping material			Stainless steel				
	Piping connections	Cold water in / Hot water out	inch	G 3/4" FEMALE				
		Recirculation connection	inch	G 3/4" FEMALE				
Sound power level	Nom.		dB(A)	44.0 (5)				
Sound pressure level	Nom.		dB(A)	30.0 (6)				

# 2 Specifications

## 2 - 1 Specifications

Technical specifications				ETVH16S18E6V7	ETVH16S23E6V7	
Operation range	Heating	Ambient	Min.	°C	0 (7)	
			Max.	°C	0 (7)	
	Water side		Min.	°C	0 (7)	
			Max.	°C	0 (7)	
	Indoor installation	Ambient	Min.	°CDB	5	
			Max.	°CDB	35 (8)	
	Cooling	Ambient	Min.	°CDB	0 (7)	
			Max.	°CDB	0 (7)	
		Water side		Min.	°C	0 (7)
				Max.	°C	0 (7)
Domestic hot water	Water side	Min.	°C	0 (7)		
		Max.	°C	0 (7)		
Safety devices	Item	01		Thermal cut out		

Electrical specifications				ETVH16S18E6V7	ETVH16S23E6V7
Power supply	Name			See note 10	
	Voltage range	Min.	%	10	
		Max.	%	10	
IP class	IP			IP X0B	
Electric heater	Power supply	Name		6V3	
		Phase		1~ / 3~	
		Frequency	Hz	50	
		Voltage	V	230	
	Current	Maximum running current	A	26.0	
		Zmax List	Ω	0.22	
		Minimum Ssc value		Equipment complying with EN/IEC 61000-3-12	
Recommended fuses		A	20.000 (9)		
Wiring connections	Communication cable	Quantity		3	
		Remark		2.5 mm <sup>2</sup>	
	Electric meter	Quantity		2	
		Remark		Minimum 0.75 mm <sup>2</sup> (5VDC pulse detection)	
	Preferential kWh rate power supply	Quantity		Power: 2	
		Remark		Power 6.3A (Select diameter and type according to national and local regulations)	
	Domestic hot water pump	Quantity		2	
		Remark		Minimum 0.75 mm <sup>2</sup> (2A inrush, 1A continuous)	
	For power supply back-up heater	Quantity		Prewired	
		Remark			
	For connection with R6T	Quantity		2	
		Remark		Minimum 0.75 mm <sup>2</sup>	
	For connection with A3P	Quantity		Depends on thermostat type, cf. installation manual	
Remark			Voltage: 230V / Max. current: 100mA / Min. 0.75mm <sup>2</sup>		
For connection with M2S	Quantity		2		
	Remark		Voltage: 230V / Max. current: 100mA / Min. 0.75mm <sup>2</sup>		
For connection with optional	Quantity		4		
	Remark		100 mA, minimum 0.75 mm <sup>2</sup>		

(1) Operation area is extended to lower flow rates only in case the unit operates with heat pump only. (Not in startup, no BUH operation, no defrost operation). |

(2) Based on a dT of 45 K |

(3) Including piping + back-up heater; excluding expansion vessel |

(4) Excluding the water in the unit. This minimum water volume is sufficient for most applications. During critical processes extra water may be required. |

(5) Measured with a pressure drop of 10 kPa in the heating system at an operating condition of leaving water 47-55°C in a room with an ambient of 20°C. DB/WB 7°C/6°. |

(6) Value measured in an anechoic room at 1m distance from the unit. It is a relative value, depending on the distance and acoustic environment. The sound pressure level mentioned is measured with a pressure drop of 10 kPa in the heating system at an operation |

(7) Refer to operation range of the unit. |

(8) Depends on operation mode, refer to installation manual. |

(9) 4 pole 20 A curve 400V tripping class C (refer to wiring diagram) |

(10) Above mentioned power supply of the hydrobox is for the backup heater only. The switch box and the pump of the hydrobox are supplied via the outdoor unit. The optional domestic hot water tank has a separate power supply.

Technical specifications				ETVH16S18E9W7	ETVH16S23E9W7
Heater capacity	Step 1		kW	3	
	Step 2		kW	max. 6 kW	
Power input	Nom.		kW	0.21	
Casing	Material			Precoated sheet metal	

## 2 Specifications

### Specifications

2

Technical specifications				ETVH16S18E9W7	ETVH16S23E9W7	
Dimensions	Unit	Height	mm	1,650	1,850	
		Width	mm		595	
		Depth	mm		625	
	Packed unit	Height	mm	1,820	2,020	
		Width	mm		720	
		Depth	mm		740	
Weight	Unit		kg	109	118	
	Packed unit		kg	126	135	
Packing	Material	Wood / Carton / PE wrapping foil / Metal				
	Weight		kg	16		
Pump	Type	Grundfos UPMXL GEO 25-125 130 PWM				
	Nr of speeds	PWM				
	Power input		W	179		
	Water side Heat exchanger	Water flow rate	Min.	l/min	20.0 (1)	
Expansion vessel	Volume		l	10		
	Max. water pressure		bar	3		
	Pre pressure		bar	1		
Tank	Name			Stainless steel domestic hot water tank 180 l	Stainless steel domestic hot water tank 230 L	
	Water volume		l	180	230	
	Material	Stainless steel (EN 1.4521)				
	Maximum water temperature		°C	70.0		
	Maximum water pressure		bar	10		
	Insulation	Material	Polyurethane foam			
		Heat loss			1.2 (2)	1.4 (2)
	Standing heat loss	S		W	50	58
	Storage volume	V		l	180	220
	Corrosion protection	Pickling				
Energy efficiency class	B					
General	Supplier/ Manufacturer details	Name or trademark	Daikin Europe N.V.			
	Name and address	Daikin Europe N.V. - Zandvoordestraat 300, 8400 Oostende, Belgium				
3-way valve	Coefficient of flow (kV)	Space heating	m <sup>3</sup> /h	8		
		Domestic hot water tank	m <sup>3</sup> /h	10		
Water circuit	Piping connections diameter		inch	G 1" (female)		
	Piping material	Cu				
	Internal piping diameter		inch	1-1/4"		
	Piping		inch	1"		
	Safety valve		bar	3		
	Manometer	Digital				
	Drain valve / fill valve	No				
	Shut off valve	Yes				
	flowswitch	Yes				
	Air purge valve	Yes				
	Total water volume		l	2.5 (3)		
	Minimum water volume in the system for cooling		l	20 (4)		
Minimum water volume in the system for heating		l	20 (4)			
Water circuit - Domestic hot water side	Piping material	Stainless steel				
	Piping connections	Cold water in / Hot water out	inch	G 3/4" FEMALE		
		Recirculation connection	inch	G 3/4" FEMALE		
Sound power level	Nom.		dB(A)	44.0 (5)		
Sound pressure level	Nom.		dB(A)	30.0 (6)		
Operation range	Heating	Ambient	Min.	°C	0 (7)	
			Max.	°C	0 (7)	
		Water side	Min.	°C	0 (7)	
			Max.	°C	0 (7)	
	Indoor installation	Ambient	Min.	°CDB	5	
			Max.	°CDB	35 (8)	
	Cooling	Ambient	Min.	°CDB	0 (7)	
			Max.	°CDB	0 (7)	
		Water side	Min.	°C	0 (7)	
			Max.	°C	0 (7)	
		Domestic Water hot water side	Min.	°C	0 (7)	
			Max.	°C	0 (7)	



## 2 Specifications

Technical specifications				ETVH16S18E9W7	ETVH16S23E9W7
Safety devices	Item	01		Thermal cut out	
Electrical specifications				ETVH16S18E9W7	ETVH16S23E9W7
Power supply	Name			See note 10	
	Voltage	Min.	%	10	
	range	Max.	%	10	
IP class	IP			IP X0B	
Electric heater supply	Power	Name		9W	
		Phase		3~	
		Frequency	Hz	50	
		Voltage	V	400	
	Current	Maximum running current	A	13.0	
	Recommended fuses			20.000 (9)	
Wiring connections	Communication cable	Quantity		3	
		Remark		2.5 mm <sup>2</sup>	
	Electric meter	Quantity		2	
		Remark		Minimum 0.75 mm <sup>2</sup> (5VDC pulse detection)	
	Preferential kWh rate power supply	Quantity		Power: 2	
		Remark		Power 6.3A (Select diameter and type according to national and local regulations)	
	Domestic hot water pump	Quantity		2	
		Remark		Minimum 0.75 mm <sup>2</sup> (2A inrush, 1A continuous)	
	For power supply back-up heater	Quantity		Prewired	
		Remark			
	For connection with R6T	Quantity		2	
		Remark		Minimum 0.75 mm <sup>2</sup>	
	For connection with A3P	Quantity		Depends on thermostat type, cf. installation manual	
		Remark		Voltage: 230V / Max. current: 100mA / Min. 0.75mm <sup>2</sup>	
For connection with M2S	Quantity		2		
	Remark		Voltage: 230V / Max. current: 100mA / Min. 0.75mm <sup>2</sup>		
For connection with optional	Quantity		4		
	Remark		100 mA, minimum 0.75 mm <sup>2</sup>		

(1)Operation area is extended to lower flow rates only in case the unit operates with heat pump only. (Not in startup, no BUH operation, no defrost operation). |

(2)Based on a dT of 45 K |

(3)Including piping + back-up heater; excluding expansion vessel |

(4)Excluding the water in the unit. This minimum water volume is sufficient for most applications. During critical processes extra water may be required. |

(5)Measured with a pressure drop of 10 kPa in the heating system at an operating condition of leaving water 47-55°C in a room with an ambient of 20°C. DB/WB 7°C/6°. |

(6)Value measured in an anechoic room at 1m distance from the unit. It is a relative value, depending on the distance and acoustic environment. The sound pressure level mentioned is measured with a pressure drop of 10 kPa in the heating system at an operatin |

(7)Refer to operation range of the unit. |

(8)Depends on operation mode, refer to installation manual. |

(9)4 pole 20 A curve 400V tripping class C (refer to wiring diagram) |

(10)Above mentioned power supply of the hydrobox is for the backup heater only. The switch box and the pump of the hydrobox are supplied via the outdoor unit. The optional domestic hot water tank has a separate power supply.

Technical specifications				ETVX16S18E6V7	ETVX16S23E6V7	
Heater capacity	Step 1		kW	2		
	Step 2		kW	2 or 4		
Power input	Nom.		kW	0.21		
Casing	Material			Precoated sheet metal		
Dimensions	Unit	Height	mm	1,650	1,850	
		Width	mm	595		
		Depth	mm	625		
	Packed unit	Height	mm	1,820	2,020	
		Width	mm	720		
		Depth	mm	740		
Weight	Unit		kg	109	118	
	Packed unit		kg	126	135	
Packing	Material			Wood / Carton / PE wrapping foil / Metal		
	Weight		kg	16		
Pump	Type			Grundfos UPMXL GEO 25-125 130 PWM		
	Nr of speeds			PWM		
	Power input		W	179		
Water side Heat exchanger	Water flow rate	Min.	l/min	20.0 (1)		

## 2 Specifications

### Specifications

2

Technical specifications				ETVX16S18E6V7	ETVX16S23E6V7	
Expansion vessel	Volume		l	10		
	Max. water pressure		bar	3		
	Pre pressure		bar	1		
Tank	Name			Stainless steel domestic hot water tank 180 l	Stainless steel domestic hot water tank 230 L	
	Water volume		l	180	230	
	Material			Stainless steel (EN 1.4521)		
	Maximum water temperature		°C	70.0		
	Maximum water pressure		bar	10		
	Insulation	Material		Polyurethane foam		
	Heat loss		kWh/24h	1.2 (2)	1.4 (2)	
	Standing heat loss	S		W	50	58
	Storage volume	V		l	180	220
	Corrosion protection			Pickling		
Energy efficiency class			B			
General	Supplier/ Name or trademark			Daikin Europe N.V.		
	Manufacturer details	Name and address		Daikin Europe N.V. - Zandvoordestraat 300, 8400 Oostende, Belgium		
3-way valve	Coefficient of flow (kV)	Space heating	m <sup>3</sup> /h	8		
		Domestic hot water tank	m <sup>3</sup> /h	10		
Water circuit	Piping connections diameter		inch	G 1" (female)		
	Piping material			Cu		
	Internal piping diameter		inch	1-1/4"		
	Piping		inch	1"		
	Safety valve		bar	3		
	Manometer			Digital		
	Drain valve / fill valve			No		
	Shut off valve			Yes		
	flowswitch			Yes		
	Air purge valve			Yes		
	Total water volume		l	2.5 (3)		
	Minimum water volume in the system for cooling		l	20 (4)		
Minimum water volume in the system for heating		l	20 (4)			
Water circuit - Domestic hot water side	Piping material			Stainless steel		
	Piping connections	Cold water in / Hot water out	inch	G 3/4" FEMALE		
	Recirculation connection		inch	G 3/4" FEMALE		
Sound power level	Nom.		dB(A)	44.0 (5)		
Sound pressure level	Nom.		dB(A)	30.0 (6)		
Operation range	Heating	Ambient	Min.	°C	0 (7)	
			Max.	°C	0 (7)	
		Water side	Min.	°C	0 (7)	
			Max.	°C	0 (7)	
	Indoor installation	Ambient	Min.	°CDB	5	
		Max.	°CDB	35 (8)		
	Cooling	Ambient	Min.	°CDB	0 (7)	
			Max.	°CDB	0 (7)	
		Water side	Min.	°C	0 (7)	
			Max.	°C	0 (7)	
		Domestic hot water side	Min.	°C	0 (7)	
			Max.	°C	0 (7)	
Safety devices	Item	01		Thermal cut out		

Electrical specifications				ETVX16S18E6V7	ETVX16S23E6V7
Power supply	Name			See note 10	
	Voltage range	Min.	%	10	
		Max.	%	10	
IP class	IP			IP X0B	
Electric heater	Power supply	Name		6V3	
		Phase		1~ / 3~	
		Frequency	Hz	50	
		Voltage	V	230	
	Current	Maximum running current	A	26.0	
		Zmax List	Ω	0.22	
		Minimum Ssc value		Equipment complying with EN/IEC 61000-3-12	
Recommended fuses		A	20.000 (9)		

## 2 Specifications

### Specifications

Electrical specifications			ETVX16S18E6V7	ETVX16S23E6V7
Wiring connections	Communication cable	Quantity	3	
		Remark	2.5 mm <sup>2</sup>	
Electric meter		Quantity	2	
		Remark	Minimum 0.75 mm <sup>2</sup> (5VDC pulse detection)	
Preferential kWh rate power supply		Quantity	Power: 2	
		Remark	Power 6.3A (Select diameter and type according to national and local regulations)	
Domestic hot water pump		Quantity	2	
		Remark	Minimum 0.75 mm <sup>2</sup> (2A inrush, 1A continuous)	
For power supply back-up heater		Quantity	Prewired	
		Remark		
For connection with R6T		Quantity	2	
		Remark	Minimum 0.75 mm <sup>2</sup>	
For connection with A3P		Quantity	Depends on thermostat type, cf. installation manual	
		Remark	Voltage: 230V / Max. current: 100mA / Min. 0.75mm <sup>2</sup>	
For connection with M2S		Quantity	2	
		Remark	Voltage: 230V / Max. current: 100mA / Min. 0.75mm <sup>2</sup>	
For connection with optional		Quantity	4	
		Remark	100 mA, minimum 0.75 mm <sup>2</sup>	

(1) Operation area is extended to lower flow rates only in case the unit operates with heat pump only. (Not in startup, no BUH operation, no defrost operation). |

(2) Based on a dT of 45 K |

(3) Including piping + back-up heater; excluding expansion vessel |

(4) Excluding the water in the unit. This minimum water volume is sufficient for most applications. During critical processes extra water may be required. |

(5) Measured with a pressure drop of 10 kPa in the heating system at an operating condition of leaving water 47-55°C in a room with an ambient of 20°C. DB/WB 7°C/6° |

(6) Value measured in an anechoic room at 1m distance from the unit. It is a relative value, depending on the distance and acoustic environment. The sound pressure level mentioned is measured with a pressure drop of 10 kPa in the heating system at an operation |

(7) Refer to operation range of the unit. |

(8) Depends on operation mode, refer to installation manual. |

(9) 4 pole 20 A curve 400V tripping class C (refer to wiring diagram) |

(10) Above mentioned power supply of the hydrobox is for the backup heater only. The switch box and the pump of the hydrobox are supplied via the outdoor unit. The optional domestic hot water tank has a separate power supply.

Technical specifications				ETVX16S18E9W7	ETVX16S23E9W7
Heater capacity	Step 1	kW	3		
	Step 2	kW	max. 6 kW		
Power input	Nom.	kW	0.21		
	Material		Precoated sheet metal		
Dimensions	Unit	Height	mm	1,650	1,850
		Width	mm	595	
		Depth	mm	625	
	Packed unit	Height	mm	1,820	2,020
		Width	mm	720	
		Depth	mm	740	
Weight	Unit	kg	109	118	
	Packed unit	kg	126	135	
Packing	Material		Wood / Carton / PE wrapping foil / Metal		
	Weight	kg	16		
Pump	Type		Grundfos UPMXL GEO 25-125 130 PWM		
	Nr of speeds		PWM		
	Power input	W	179		
Water side Heat exchanger	Water flow rate	Min.	l/min	20.0 (1)	
	Expansion vessel	Volume	l	10	
Max. water pressure		bar	3		
Pre pressure		bar	1		

## 2 Specifications

### Specifications

2

Technical specifications				ETVX16S18E9W7	ETVX16S23E9W7	
Tank	Name		Stainless steel domestic hot water tank 180 l		Stainless steel domestic hot water tank 230 L	
	Water volume	l	180		230	
	Material		Stainless steel (EN 1.4521)			
	Maximum water temperature	°C	70.0			
	Maximum water pressure	bar	10			
	Insulation	Material		Polyurethane foam		
		Heat loss	kWh/24h	1.2 (2)	1.4 (2)	
	Standing S heat loss	W	50		58	
	Storage V volume	l	180		220	
	Corrosion protection		Pickling			
Energy efficiency class		B				
General	Supplier/ Name or trademark	Daikin Europe N.V.				
	Manufacturer Name and address details	Daikin Europe N.V. - Zandvoordestraat 300, 8400 Oostende, Belgium				
3-way valve	Coefficient of Space heating	m <sup>3</sup> /h	8			
	Domestic hot water tank flow (kV)	m <sup>3</sup> /h	10			
Water circuit	Piping connections diameter		inch			
	Piping material		G 1" (female)			
	Internal piping diameter		inch			
	Piping		inch			
	Safety valve		bar			
	Manometer		Digital			
	Drain valve / fill valve		No			
	Shut off valve		Yes			
	flowswitch		Yes			
	Air purge valve		Yes			
	Total water volume		l	2.5 (3)		
	Minimum water volume in the system for cooling		l	20 (4)		
Minimum water volume in the system for heating		l	20 (4)			
Water circuit - Domestic hot water side	Piping material		Stainless steel			
	Piping connections	Cold water in / Hot water out inch	G 3/4" FEMALE			
	Recirculation connection	inch	G 3/4" FEMALE			
Sound power level	Nom.	dB(A)	44.0 (5)			
Sound pressure level	Nom.	dB(A)	30.0 (6)			
Operation range	Heating	Ambient	Min.	°C	0 (7)	
			Max.	°C	0 (7)	
	Water side	Ambient	Min.	°C	0 (7)	
			Max.	°C	0 (7)	
	Indoor installation	Ambient	Min.	°CDB	5	
			Max.	°CDB	35 (8)	
	Cooling	Ambient	Min.	°CDB	0 (7)	
			Max.	°CDB	0 (7)	
	Water side	Ambient	Min.	°C	0 (7)	
			Max.	°C	0 (7)	
Domestic hot water side	Water	Min.	°C	0 (7)		
		Max.	°C	0 (7)		
Safety devices	Item	01	Thermal cut out			

Electrical specifications				ETVX16S18E9W7	ETVX16S23E9W7	
Power supply	Name		See note 10			
	Voltage range	Min.	%	10		
		Max.	%	10		
IP class	IP		IP X0B			
Electric heater	Power supply	Name		9W		
		Phase		3~		
		Frequency	Hz	50		
	Voltage		V		400	
	Current	Maximum running current		A		13.0
		Recommended fuses		A		20.000 (9)

## 2 Specifications

### Specifications

Electrical specifications			ETVX16S18E9W7	ETVX16S23E9W7
Wiring connections	Communication cable	Quantity	3	
		Remark	2.5 mm <sup>2</sup>	
Electric meter		Quantity	2	
		Remark	Minimum 0.75 mm <sup>2</sup> (5VDC pulse detection)	
Preferential kWh rate power supply		Quantity	Power: 2	
		Remark	Power 6.3A (Select diameter and type according to national and local regulations)	
Domestic hot water pump		Quantity	2	
		Remark	Minimum 0.75 mm <sup>2</sup> (2A inrush, 1A continuous)	
For power supply back-up heater		Quantity	Prewired	
For connection with R6T		Quantity	2	
		Remark	Minimum 0.75 mm <sup>2</sup>	
For connection with A3P		Quantity	Depends on thermostat type, cf. installation manual	
		Remark	Voltage: 230V / Max. current: 100mA / Min. 0.75mm <sup>2</sup>	
For connection with M2S		Quantity	2	
		Remark	Voltage: 230V / Max. current: 100mA / Min. 0.75mm <sup>2</sup>	
For connection with optional		Quantity	4	
		Remark	100 mA, minimum 0.75 mm <sup>2</sup>	

(1) Operation area is extended to lower flow rates only in case the unit operates with heat pump only. (Not in startup, no BUH operation, no defrost operation). |

(2) Based on a dT of 45 K |

(3) Including piping + back-up heater; excluding expansion vessel |

(4) Excluding the water in the unit. This minimum water volume is sufficient for most applications. During critical processes extra water may be required. |

(5) Measured with a pressure drop of 10 kPa in the heating system at an operating condition of leaving water 47-55°C in a room with an ambient of 20°C. DB/WB 7°C/6° |

(6) Value measured in an anechoic room at 1m distance from the unit. It is a relative value, depending on the distance and acoustic environment. The sound pressure level mentioned is measured with a pressure drop of 10 kPa in the heating system at an operation |

(7) Refer to operation range of the unit. |

(8) Depends on operation mode, refer to installation manual. |

(9) 4 pole 20 A curve 400V tripping class C (refer to wiring diagram) |

(10) Above mentioned power supply of the hydrobox is for the backup heater only. The switch box and the pump of the hydrobox are supplied via the outdoor unit. The optional domestic hot water tank has a separate power supply.

# 3 Electrical data

## 3 - 1 Electrical Data

3

ETVH16E6V7  
 ETVH16UE6V7  
 ETVH16E9W7  
 ETVX16E6V7  
 ETVX16E9W7  
 ETVZ16E6V7  
 ETVZ16E9W7

### Electrical specifications

Type	6V						9W											
			2-4		2-6		4-6		2-4 (in case of emergency: 2-6)		6		3-6		3-9		3-6 (in case of emergency: 3-9)	
Capacity setting		[kW]	2	2	2	2	2	2	2	2	1	2	2	2	2	2	2	2
Capacity stage			2	2	2	2	2	2	2	2	6	3	3	3	3	3	3	3
Capacity stage 1		kW	2	2	2	2	2	2	2	2	6	3	3	3	3	3	3	3
Capacity stage 2		kW	4	6	4	4	4	4	4	6	-	6	9	6	9	6	9	9
Backup heater	Minimum time delay between stages		Note 4						Note 4									
	Power supply (1)	Phase	1~						3~									
		Frequency	50						50									
	Voltage		230 +-10%						400 +-10%									
		Nominal running current	A	17,4	26,1	26,1	17,4	26,1	15	8,7	13	8,7	13	8,7	13	8,7	13	8,7
	Current	Zmax (backup heater)(2)	Ω															
Minimum Ssc value		kVA	(3)						(3)									

Notes	
(1)	The above-mentioned power supply of the hydrobox is for the backup heater only.
(2)	Booster heater power supply In accordance with EN/IEC 61000-3-11, it may be necessary to consult the distribution network operator to ensure that the equipment is connected only to a supply with Zsys ≤ Zmax.
(3)	The equipment complies with EN/IEC 61000-3-12.
EN/IEC 61000-3-11	European/International Technical Standard setting the limits for voltage changes, voltage fluctuations and flicker in public low-voltage supply systems for equipment with rated current ≤ 75 A.
EN/IEC 61000-3-12	European/International Technical Standard setting the limits for harmonic currents produced by equipment connected to public low-voltage systems with input current > 16 A and ≤ 75 A per phase.
Zsys	System impedance

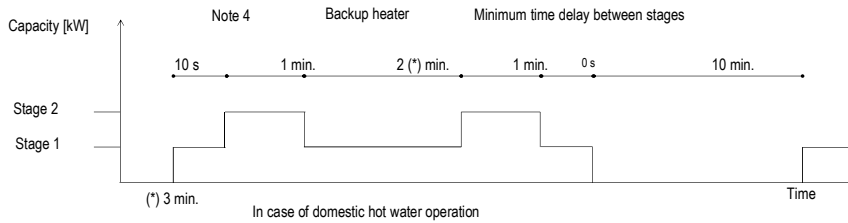

4D121000A

# 3 Electrical data

## 3 - 1 Electrical Data

ETBH16E6V7 / ETBH16E9W7 / ETBX16E6V7 / ETBX16E9W7  
 ETVH16E6V7 / ETVH16UE6V7 / ETVH16E9W7  
 ETVX16E6V7 / ETVX16E9W7  
 ETVZ16E6V7 / ETVZ16E9W7

**\* Electrical meter specification**

- Pulse meter type/voltage-free contact for 5 V DC detection by PCB.
- Possible number of pulses
  - 0.1· pulse/kWh
  - 1· pulse/kWh
  - 10· pulse/kWh
  - 100· pulse/kWh
  - 1000· pulse/kWh
- Pulse duration
  - minimum On time: ·40ms·
  - Minimum OFF time: ·100ms·
- Measurement type (depending on installation)
  - Single-phase AC meter
  - Three-phase AC meter
    - Balanced loads
    - Unbalanced loads

**\* Electrical meter installation guideline**

- It is the responsibility of the installer to cover the complete power consumption with electrical meters (combination of estimation and metering is not allowed).
- Required number of electrical meters

Outdoor unit type		EPRA(14/16/18)(D/E)*					
Indoor unit type		ETB(H/X)16(D/E)*			ETV(H/X/Z)16S*(D/E)*		
	Backup heater type	6V		9W	6V		9W
	Backup heater power supply	1~ 230V	3~ 230V	3~ 400V	1~ 230V	3~ 230V	3~ 400V
	Backup heater configuration	2 / 4 / 6 kW	6 kW	3 / 6 / 9 kW	2 / 4 / 6 kW	6 kW	3 / 6 / 9 kW
<b>Normal kWh rate power supply</b>							
Electrical meter type	1~	1	-	-	1	-	-
	3~ balanced	-	-	-	-	-	-
	3~ unbalanced	-	1	1	-	1	1
<b>Preferential kWh rate power supply</b>							
Electrical meter type	1~	2	1	1	2	1	1
	3~ balanced	-	-	-	-	-	-
	3~ unbalanced	-	1	1	-	1	1

4D126533B

# 4 Combination table

## 4 - 1 Combination Table

### ETVH16E6V7 / ETVH16UE6V7 / ETVH16E9W7 / ETVX16E6V7 / ETVX16E9W7

**Factory-mounted equipment for ·ETV(H/X/Z)16S\*E\*7·**

Description	ETV(H/X/Z)16S*E*7			
	18 - 6V (9)	18 - 9W (9)	23 - 6V (9)	23 - 9W (9)
Heating only model ·ETVH*7·	18 - 6V (9)	18 - 9W (9)	23 - 6V (9)	23 - 9W (9)
Reversible model ·ETVX*7·	18 - 6V (9)	18 - 9W (9)	23 - 6V (9)	23 - 9W (9)
(Integrated Bizzone)	18 - 6V (9)	18 - 9W (9)	23 - 6V (9)	23 - 9W (9)
Heating only indoor unit for the UK	18 - 6V (9)		23 - 6V (9)	
Backup heater ·2-4-6kW 1N-230 V·	o	-	o	-
Backup heater ·2-4-6kW 3-230 V·	o	-	o	-
Backup heater ·3-6-9kW 3N-400 V·	-	o	-	o
Domestic hot water tank ·180L·	o	o	-	-
Domestic hot water tank ·230L·	-	-	o	o

**Outdoor combination table for ·ETV(H/X/Z)16S(U)(18/23)E\*7·**

		EPR14DA(V3/W1)7	EPR16DA(V3/W1)7	EPR18DA(V3/W1)7
ETVH16S(18/23)E*7	Heating only indoor unit	o	o	o
ETVX16S(18/23)E*7	Reversible indoor unit	o	o	o
ETVZ16S(18/23)E*7	(Integrated Bizzone)	o	o	o
ETVH16SU(18/23)E*7	Heating only indoor unit for the UK	o	o	o

**Kit availability**

Reference	Description	ETV*16S*E*7				ETVH16SU*E*7	
		18 - 6V	18 - 9W	23 - 6V	23 - 9W	18 - 6V	23 - 6V
ETVH*7	Heating only indoor unit	18 - 6V	18 - 9W	23 - 6V	23 - 9W		
ETVX*7	Reversible indoor unit	18 - 6V	18 - 9W	23 - 6V	23 - 9W		
ETVZ*7	(Integrated Bizzone)	18 - 6V	18 - 9W	23 - 6V	23 - 9W		
ETVH*U*7	Heating only indoor unit for the UK	18 - 6V	18 - 9W	23 - 6V	23 - 9W	18 - 6V	23 - 6V
EKRP1HBAA	Digital I/O PCB	*(1) (2)	o	o	o	o	o
EKRP1AHTA	Demand PCB	*(3)	o	o	o	o	o
EKPCAB4	PC cable	*(4)	o	o	o	o	o
KRCS01-1	Remote indoor sensor	*(5)	o	o	o	o	o
EKSCA1	Remote sensor for outdoor	*(5)	o	o	o	o	o
EKCC8-W	Universal centralised user interface	o	o	o	o	o	o
DCOM-LT/IO	DCOM gateway	o	o	o	o	o	o
DCOM-LT/MB	DCOM gateway	o	o	o	o	o	o
EKHVCONV4	Conversion kit: heating only to reversible.	o	o	o	o	o	o
EKUHMG3D	·G3· kit					o (6)	o (6)
BRP069A71	WLAN module	*(7)	o	o	o	o	o
BRCHHDA*	HCI (Human Comfort Interface)	o	o	o	o	o	o
ESAE04A01*	Daikin Residential Controller	o	o	o	o	o	o
EKRELSG	Relay for Smart Grid	o	o	o	o	o	o
AFVALVE1	Freeze protection valve	o	o	o	o	o	o
FWXV10-15-20ATV3*	Heat pump convector	*(8)	o	o	o	o	o
FWXT10-15-20ATV3*	Heat pump convector	*(8)	o	o	o	o	o
FWXM10-15-20ATV3*	Heat pump convector	*(8)	o	o	o	o	o
EKVHPC	Heat pump convector valve kit	*(8)	o	o	o	o	o
EKRTHA	Wired room thermostat	o	o	o	o	o	o
EKRTRB	Wireless room thermostat	o	o	o	o	o	o
EKRTEIS	External sensor room thermostat	*(10)	o	o	o	o	o
EKWUFHTA1V3	Multi-zoning base unit 230 V	*(11)	o	o	o	o	o
EKWCTRD1V3	Digital thermostat 230 V	*(11)	o	o	o	o	o
EKWCTRAN1V3	Analogue thermostat 230 V	*(11)	o	o	o	o	o
EKWCVATR1V3	Actuator 230 V	*(11)	o	o	o	o	o
HYDRA*	Hydrofast connection kit for field piping	o	o	o	o	o	o
HBKIT*	Easy floor standing installation kit	o	o	o	o	o	o
HBKITZZ	Easy floor standing bizzone extension kit	*(14)(15)	o	o	o	o	o
HBACCO0*	Easy floor standing installation side piping extension kit	*(14)	o	o	o	o	o

Reference	Description	ETVH*7		ETVX*7	
		ETVH*7	ETVX*7	ETVH*7	ETVX*7
	Only applicable for ·ETVH*7 & ETVX*7· models				
EKMIKPOA	Mixing kit - PCB only	o	o		
EKMIKPHA	Mixing kit - PCB with hydraulics	o	o		
EKMIKHMA	Hydraulics - mixed pump group	*(12)	o		
EKMIKHUA	Hydraulics - unmixed pump group	*(12)	o		
EKMIKBVA	Balancing vessel	o	o		
EKMIKDIA	Distributor for balancing vessel	*(13)	o		

**Kit availability for outdoor units**

Reference	Description	EPR14DA(V3/W1)7	EPR16DA(V3/W1)7	EPR18DA(V3/W1)7
EKMST1	Mounting stand	o	o	o
EKMST2	Mounting stand	o	o	o

**Notes**

- (1) PCB that provides additional output connections:
  - (a) Control external heat source (bivalent operation).
  - (b) Output remote ON/OFF signal space heating/cooling
  - (c) Remote alarm output
- (2) Additional relays to allow bivalent control in combination with an external room thermostat are field-supplied.
- (3) PCB to receive up to ·4· digital inputs for power limitation
- (4) Data cable for connection with PC.
- (5) Only 1 remote sensor can be connected: indoor OR outdoor sensor.
- (6) This kit is mandatory for the UK models.
- (7) The WLAN cartridge is supplied in the accessory bag of the unit and is meant to be plugged into the SD card slot on the MMI-2. In case of bad signal reception, the WLAN cartridge can be removed and replaced by the WLAN module.
- (8) The valve kit is mandatory if a heat pump convector is installed on a reversible model (not mandatory for heating only models).
- (9) The backup heater capacity depends on a user interface setting.
- (10) ·EKRTET5· can only be used in combination with ·EKRTTB·
- (11) Multi-zoning wired controls
- (12) Only possible in combination with ·EKMIKPOA·
- (13) Only possible in combination with ·EKMIKPHA· and ·EKMIKHUA·
- (14) Only possible in combination with ·HBKIT\*·
- (15) Only possible in combination with ·ETVZ\*·

**Remark**

Other combinations than mentioned in this combination table are prohibited.

**3D140832A**



# 5 Capacity tables

## 5 - 1 Domestic Hot Water performance

ETVH16E6V7  
 ETVH16UE6V7  
 ETVH16E9W7  
 ETVX16E6V7  
 ETVX16E9W7  
 ETVZ16E6V7  
 ETVZ16E9W7

**Heat-up times**

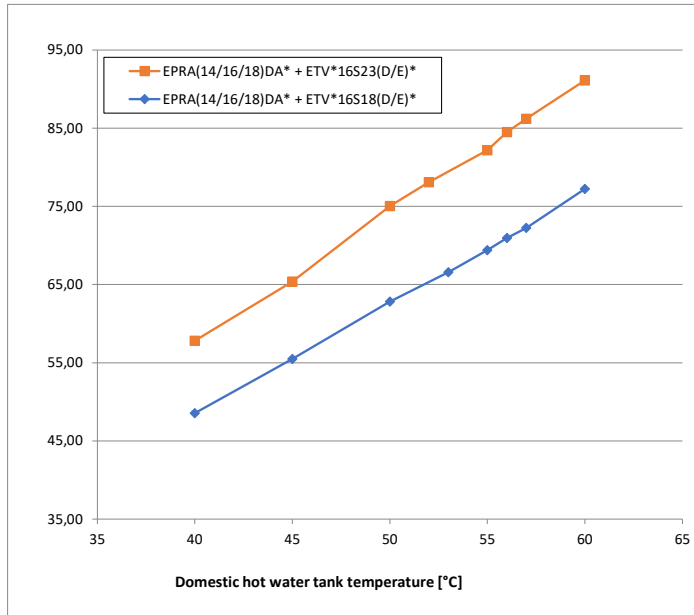

Model name	Heat-up time domestic hot water tank until 45°C
EPRA(14/16/18)DA* + ETV*16S18(D/E)*	55 min.
EPRA(14/16/18)DA* + ETV*16S23(D/E)*	65 min.

**Notes**

1. Time the indoor unit (**heat pump only operation**) requires to heat up the domestic hot water tank from 10°C to the indicated temperature.

See the operation range for maximum domestic hot water tank temperature during heat pump only operation.

4D126944B

ETVH16E6V7 / ETVH16UE6V7 / ETVH16E9W7 / ETVX16E6V7 / ETVX16E9W7 / ETVZ16E6V7 / ETVZ16E9W7

**Selection guide for the domestic hot water tank volume**

(1)

Ve<sub>q</sub> 40°C = the amount of water with a temperature of 40°C that can be tapped when the domestic hot water tank is heated to a certain temperature, and the temperature of the cold inlet water is 10°C.

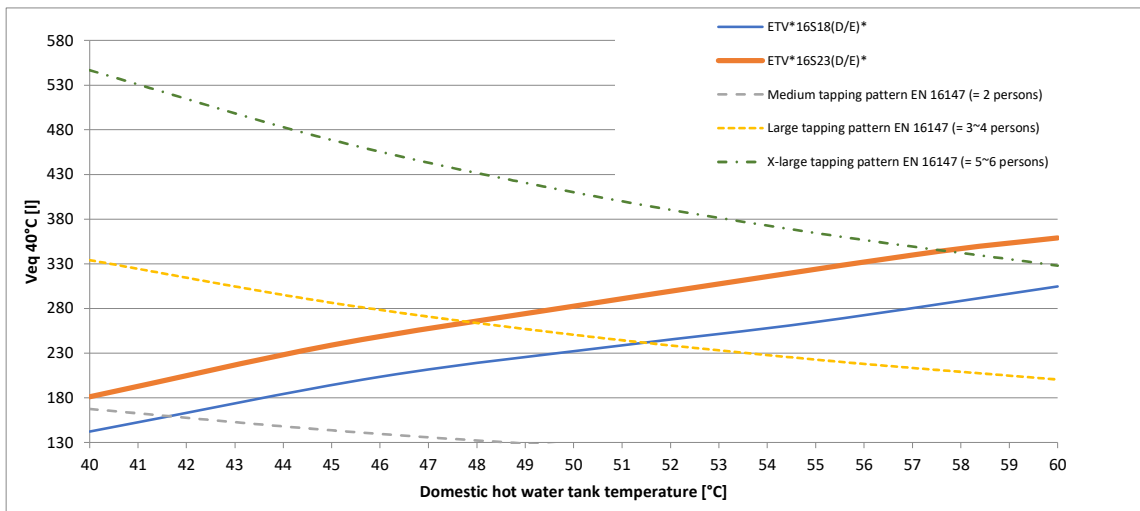

If a higher daily Ve<sub>q</sub> 40°C is required, then additional heat-up cycles are required within 24 hours. See the operation manual for more information.

**Notes**

(1) According to EN16147.

4D126944B

# 6 Dimensional drawings

## 6 - 1 Dimensional Drawings

6

ETVH16E6V7  
 ETVH16E9W7  
 ETVX16E6V7  
 ETVX16E9W7

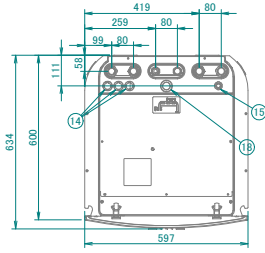
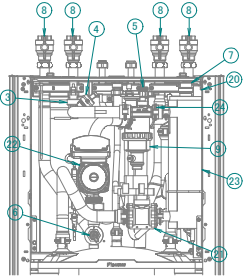

- ① Water out connection ·1"· To outdoor unit
- ② Water in connection ·1"·
- ③ Flow switch
- ④ Space heating water pressure sensor
- ⑤ Safety valve
- ⑥ Drain valve water circuit
- ⑦ Air purge
- ⑧ Shut-off valve
- ⑨ Magnetic filter / dirt separator
- ⑩ Water in connection ·1" F BSP·
- ⑪ Water out connection ·1" F BSP·
- ⑫ Domestic hot water: cold water in ·3/4" F BSP·
- ⑬ Domestic hot water: hot water out ·3/4" F BSP·
- ⑭ High voltage wiring intake ·Ø 24mm·
- ⑮ Low voltage wiring intake ·Ø 15mm·
- ⑯ Levelling feet
- ⑰ User interface
- ⑱ Recirculation connection ·G 3/4"· (female)
- ⑲ Drain outlet (unit + safety valve)
- ⑳ Expansion vessel
- ㉑ 3-way valve
- ㉒ Pump
- ㉓ Backup heater
- ㉔ Flow sensor

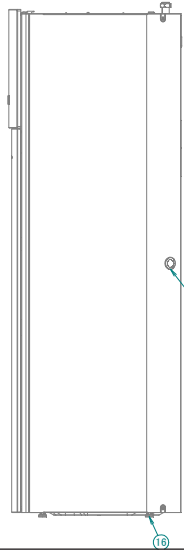
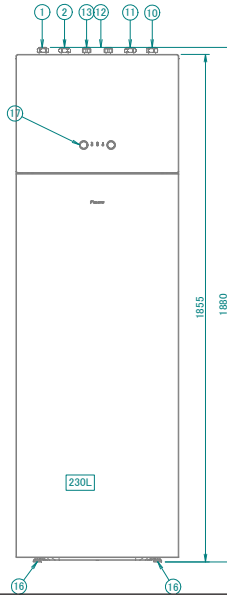
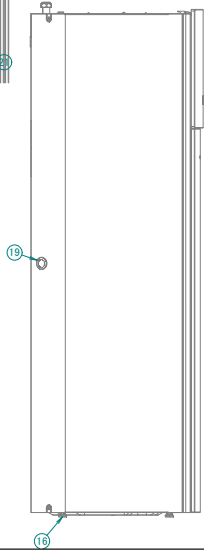
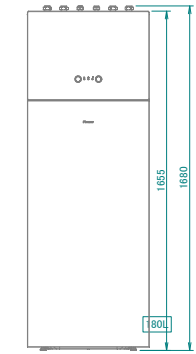

Screws used in this unit:



**3D121002B**

# 7 Centre of gravity

7 - 1 Centre of Gravity

ETVH16E6V7  
 ETVH16UE6V7  
 ETVH16E9W7  
 ETVX16E6V7  
 ETVX16E9W7  
 ETVZ16E6V7  
 ETVZ16E9W7

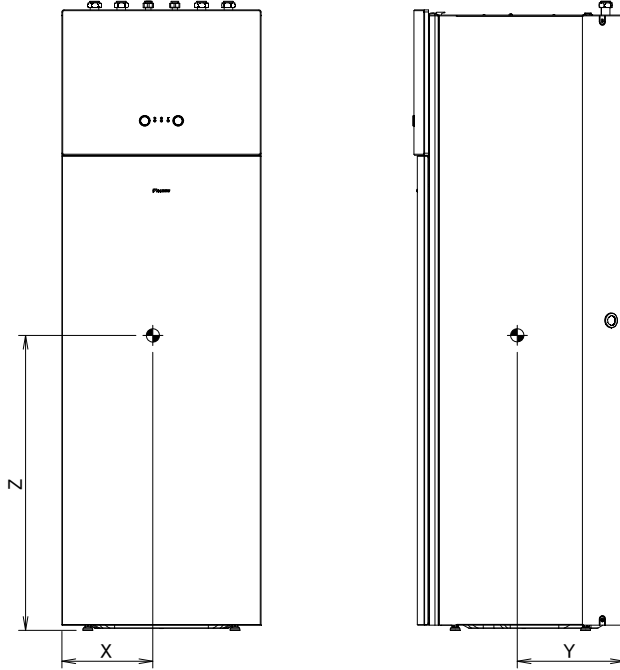

MODEL	X	Y	Z
EAV (H/X) 16S18*	327	329	890
EAV (H/X) 16S23*	327	329	1015
EAVZ16S18*	311	315	903
EAVZ16S23*	311	315	1028
ETV (H/X) 16S18*	327	329	890
ETV (H/X) 16S23*	327	329	1015
ETVZ16S18*	311	315	903
ETVZ16S23*	311	315	1028
ETV (H/X) 12S18*	327	329	890
ETV (H/X) 12S23*	327	329	1015
ETVZ12S18*	311	315	903
ETVZ12S23*	311	315	1028
ETVH12SU18*	327	329	890
ETVH12SU23*	327	329	1015
ETVH16SU18*	327	329	890
ETVH16SU23*	327	329	1015

**3D121014D**

# 8 Piping diagrams

## 8 - 1 Piping Diagrams

8

ETVH16E6V7  
 ETVH16UE6V7  
 ETVH16E9W7  
 ETVX16E6V7  
 ETVX16E9W7

- ① Space heating - water OUT
- ② Space heating - water IN
- ③ Domestic hot water: hot water out -3/4"
- ④ Domestic hot water: cold water in -3/4"
- ⑤ Shut-off valve -1" (male-female)
- ⑥ Expansion vessel
- ⑦ Magnetic filter / dirt separator
- ⑧ Safety valve
- ⑨ Air purge
- ⑩ Drain valve
- ⑪ Pump
- ⑫ Flow switch
- ⑬ Space heating water pressure sensor
- ⑭ Flow sensor
- ⑮ Backup heater
- ⑯ 3-way valve (space heating/domestic hot water)
- ⑰ R1T - Inlet water thermistor
- ⑱ R2T - Outlet water backup heater thermistor
- ⑲ R5T - Tank thermistor
- ⑳ R8T - Tank thermistor
- Field piping connections
- ㉑ Water in connection -1"
- ㉒ Water out connection -1"
- ㉓ Screw connection -1"

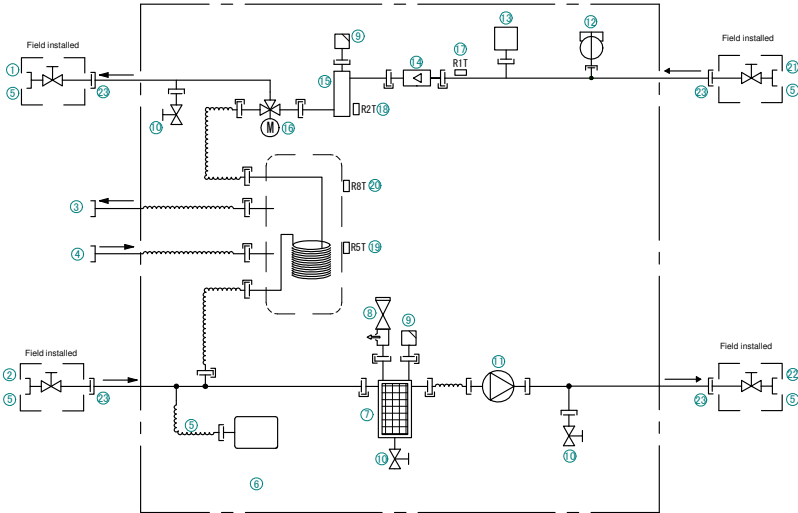

Screw connection	Brazed connection
Quick coupling	Flare connection

3D120611B

# 9 Wiring diagrams

## 9 - 1 Notes & Legend

### ETVH16E6V7 / ETVH16UE6V7 / ETVH16E9W7 / ETVX16E6V7 / ETVX16E9W7

#### NOTES to go through before starting the unit

- X1M : Main terminal
- X2M : Field wiring terminal for AC
- X5M : Field wiring terminal for DC
- X6M : BUH Power supply terminal
- X10M : Smartgrid terminal
- · — · — · — : Earth wiring
- — — — — : Field supply
- ① : Several wiring possibilities

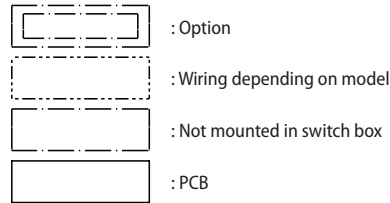

#### NOTES

1. Connection point of the power supply for the BUH should be foreseen outside the unit.

- Backup heater power supply
  - 6T1 (3~, 230V, 6kW)
  - 6V3 (1N~, 230V, 6kW)
  - 6WN/9WN (3N~, 400V, 6/9kW)
- User installed options:
  - LAN adapter
  - Remote user interface
  - Ext. indoor thermistor
  - Ext. outdoor thermistor
  - Digital I/O PCB
  - Demand PCB
  - Safety thermostat
  - Smartgrid
  - WLAN adapter module
  - WLAN cartridge
  - Bizonex mixing kit
- Main LWT:
  - ON/OFF thermostat (wired)
  - ON/OFF thermostat (wireless)
    - Ext. thermistor
  - Heat pump convector
- Add LWT:
  - ON/OFF thermostat (wired)
  - ON/OFF thermostat (wireless)
    - Ext. thermistor
  - Heat pump convector

#### POSITION IN SWITCH BOX

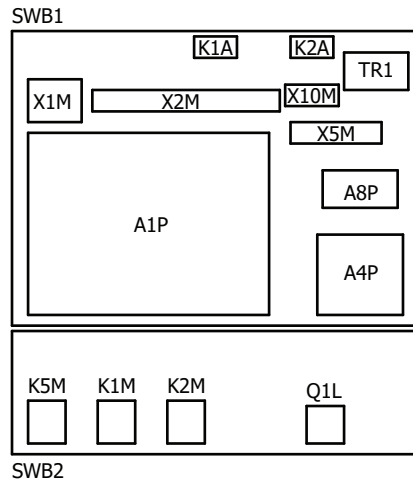

#### LEGEND

Part n°	Description	Part n°	Description
A1P	main PCB	Q4L	# safety thermostat
A2P	* ON/OFF thermostat (PC=power circuit)	Q*DI	# earth leakage circuit breaker
A3P	* heat pump convector	R1H (A2P)	* humidity sensor
A4P	* digital I/O PCB	R1T (A1P)	inlet water thermistor
A8P	* demand PCB	R1T (A2P)	* ambient sensor ON/OFF thermostat
A9P	status indicator	R1T (A14P)	* ambient sensor user interface
A11P	MMI main PCB	R2T (A1P)	outlet backup heater thermistor
A13P	* LAN adapter	R2T (A2P)	* external sensor (floor or ambient)
A14P	* user interface PCB	R5T, R8T	domestic hot water thermistor
A15P	* receiver PCB (wireless ON/OFF thermostat)	R6T	* external indoor or outdoor ambient thermistor
A20P	* WLAN module	S1L	flow switch
A30P	* Bizonex mixing kit PCB	S1S	# preferential kWh rate PS contact
B2L	flow sensor	S2S	# electrical meter pulse input 1
B1PW	water pressure sensor	S3S	# electrical meter pulse input 2
CN* (A4P)	* connector	S4S	# smart grid feed-in
DS1 (A8P)	* dipswitch	S6S-S9S	* digital power limitation inputs
E1H	backup heater element (1 kW)	S10S-S11S	# low voltage smartgrid contact
E2H	backup heater element (2 kW)	SS1 (A4P)	* selector switch
E*P (A9P)	indication LED	SW1~2 (A11P)	turn buttons
F1B	# overcurrent fuse backup heater	SW3~5 (A11P)	push button
F1T	thermal fuse backup heater	TR1	power supply transformer
F1U, F2U (A4P)	* fuse 5 A 250 V for digital I/O PCB	X6M	# BUH power supply terminal strip
FU1 (A1P)	fuse T 5A 250V for PCB	X10M	* smartgrid power supply terminal strip
K1A, K2A	* high voltage smartgrid relay	X*, X*A, J*	connector
K1M, K2M	contactor backup heater	X*H*, X*Y	
K5M	safety contactor BUH	X*M	terminal strip
K*R (A1P-A4P)	relay on PCB		
M1P	main supply pump		
M2P	# domestic hot water pump		
M2S	# 2 way valve for cooling mode		
M3S	# 3 way valve for spaceheating /domestic hot water		
P1M	MMI display		
PC (A15P)	* power circuit		
PHC1 (A4P)	* optocoupler input circuit		
Q1L	thermal protector backup heater		

\* : optional # : field supply

4D133210E

# 9 Wiring diagrams

## 9 - 2 Control Circuit

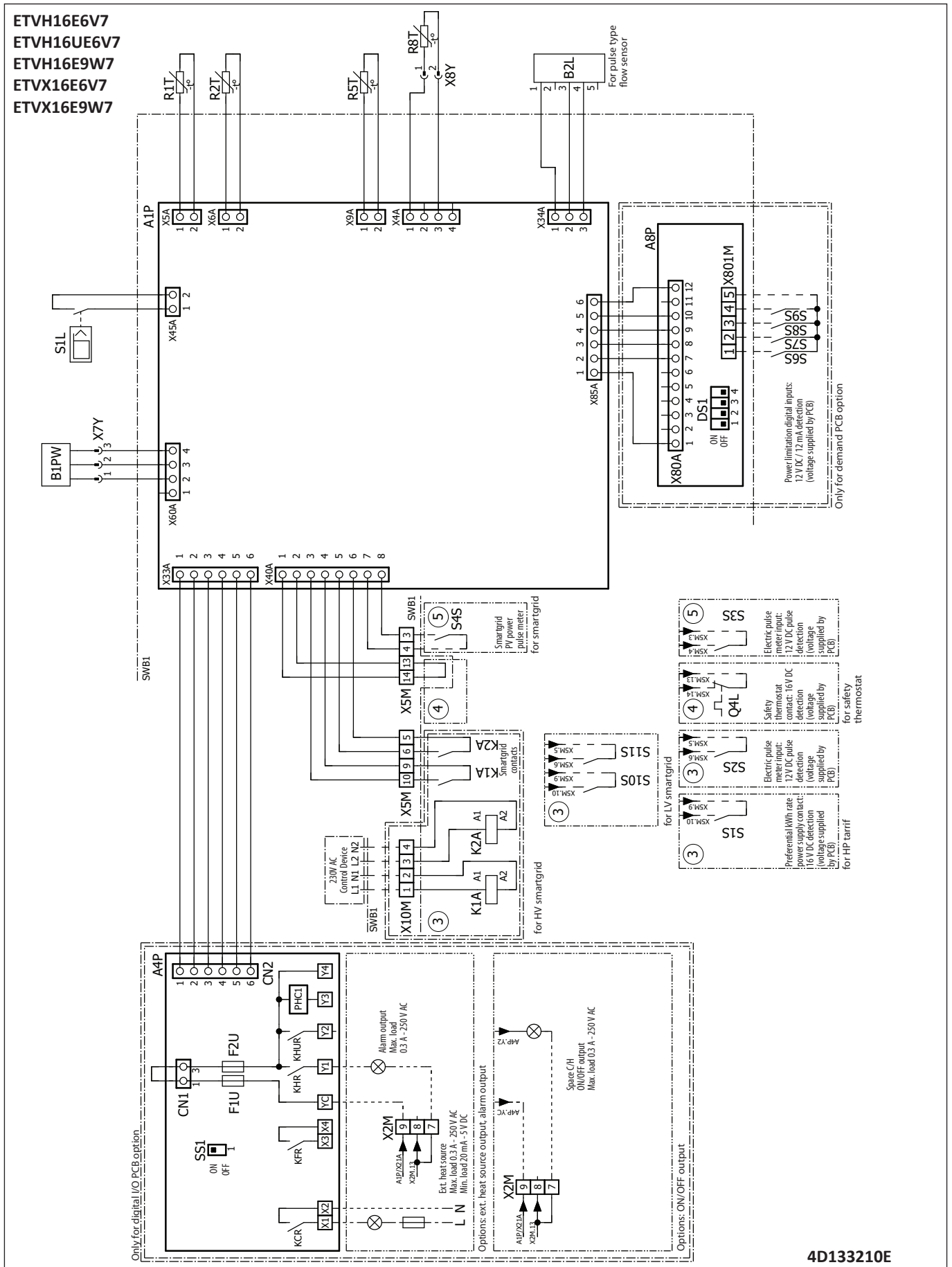

# 9 Wiring diagrams

## 9 - 2 Control Circuit

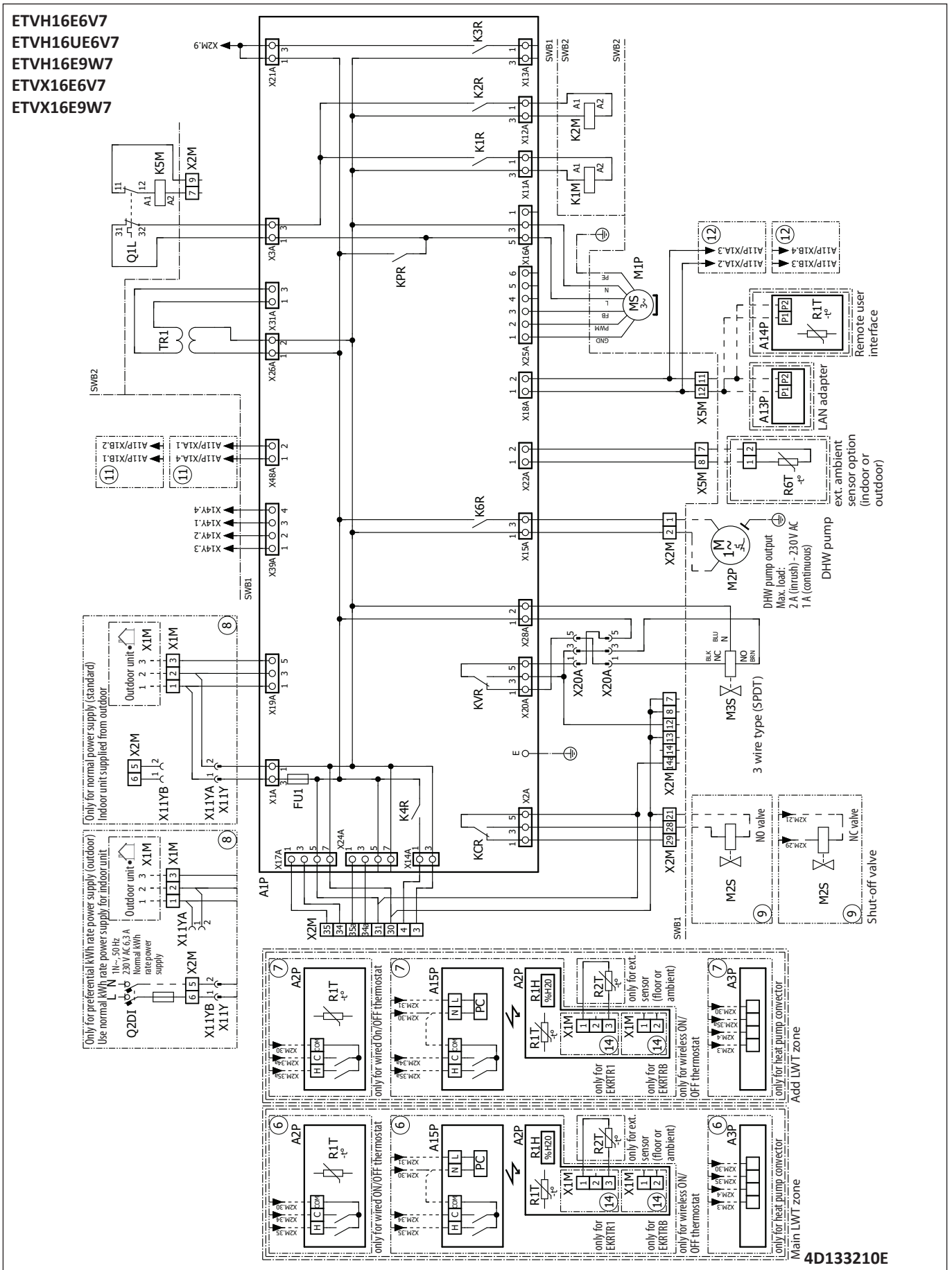

# 9 Wiring diagrams

## 9 - 2 Control Circuit

9

ETVH16E6V7  
 ETVH16UE6V7  
 ETVH16E9W7  
 ETVX16E6V7  
 ETVX16E9W7

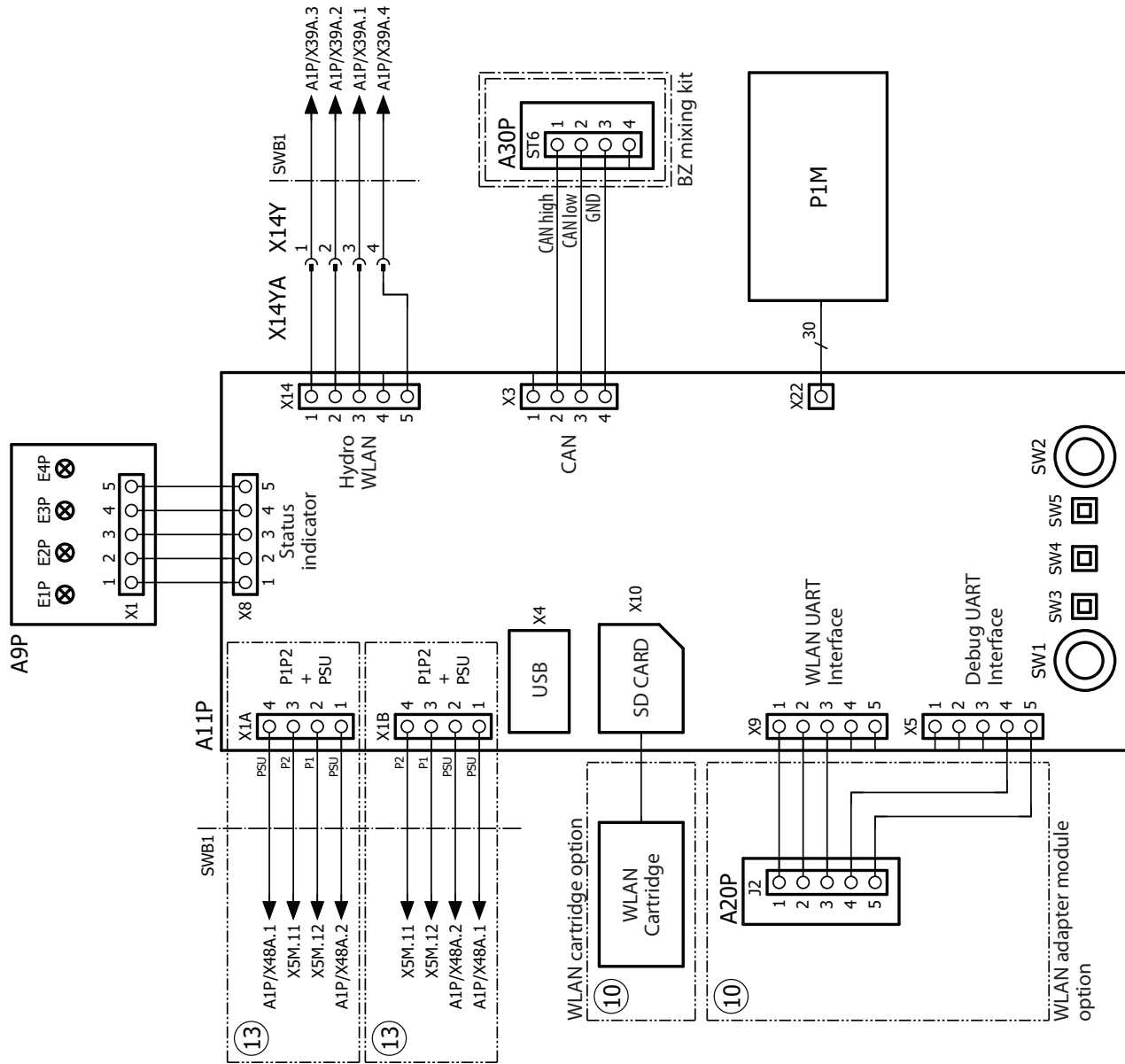

4D133210E



# 9 Wiring diagrams

## 9 - 3 Power Supply, Back-up Heater

ETVH16E6V7  
 ETVH16UE6V7  
 ETVH16E9W7  
 ETVX16E6V7  
 ETVX16E9W7

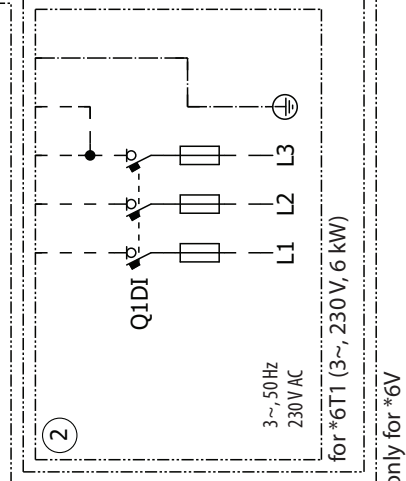
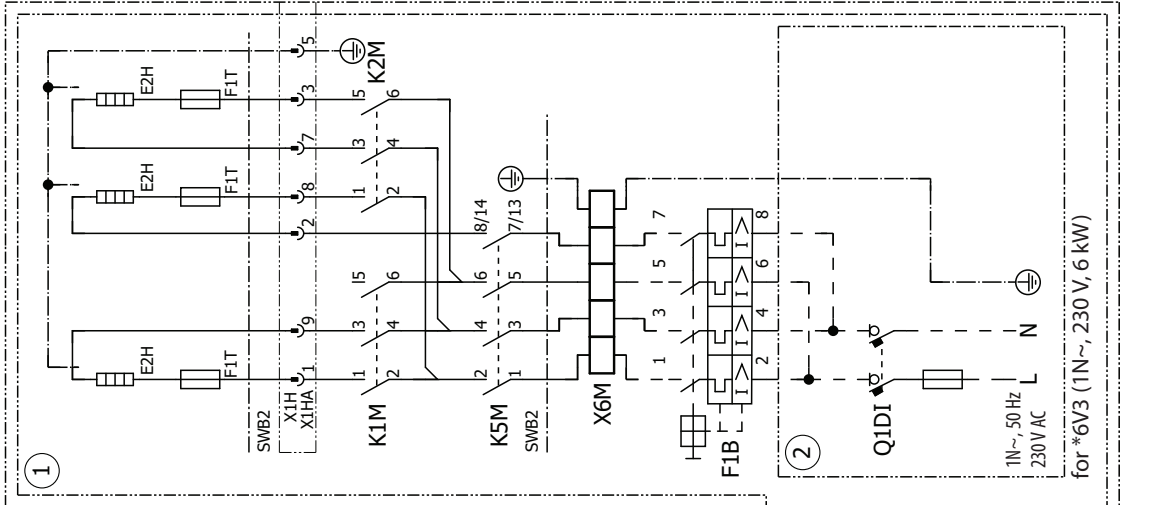
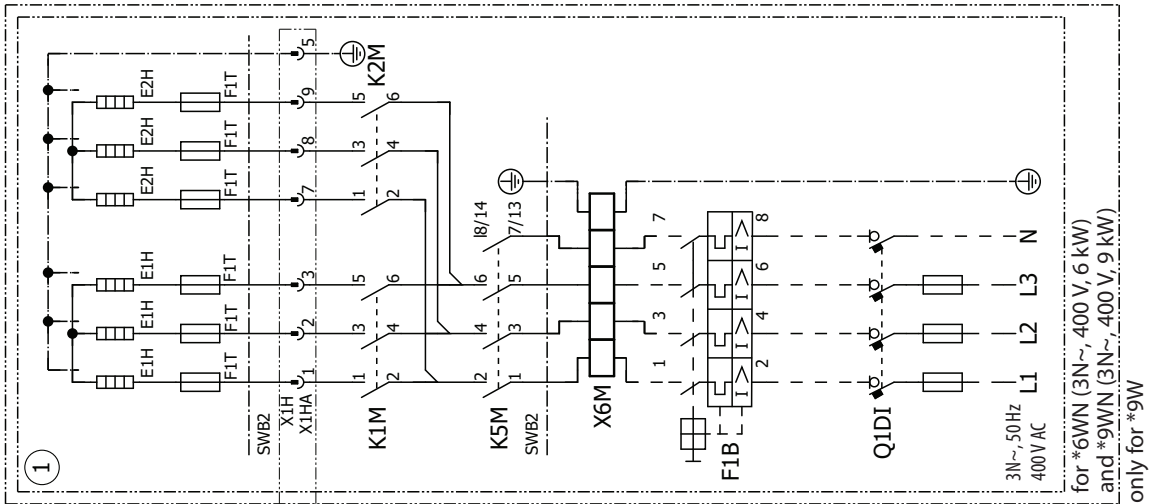
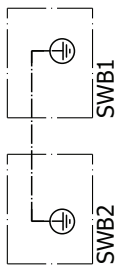

4D133210E

# 10 External connection diagrams

## 10 - 1 External Connection Diagrams

10

ETVH16E6V7  
 ETVH16UE6V7  
 ETVH16E9W7  
 ETVX16E6V7  
 ETVX16E9W7

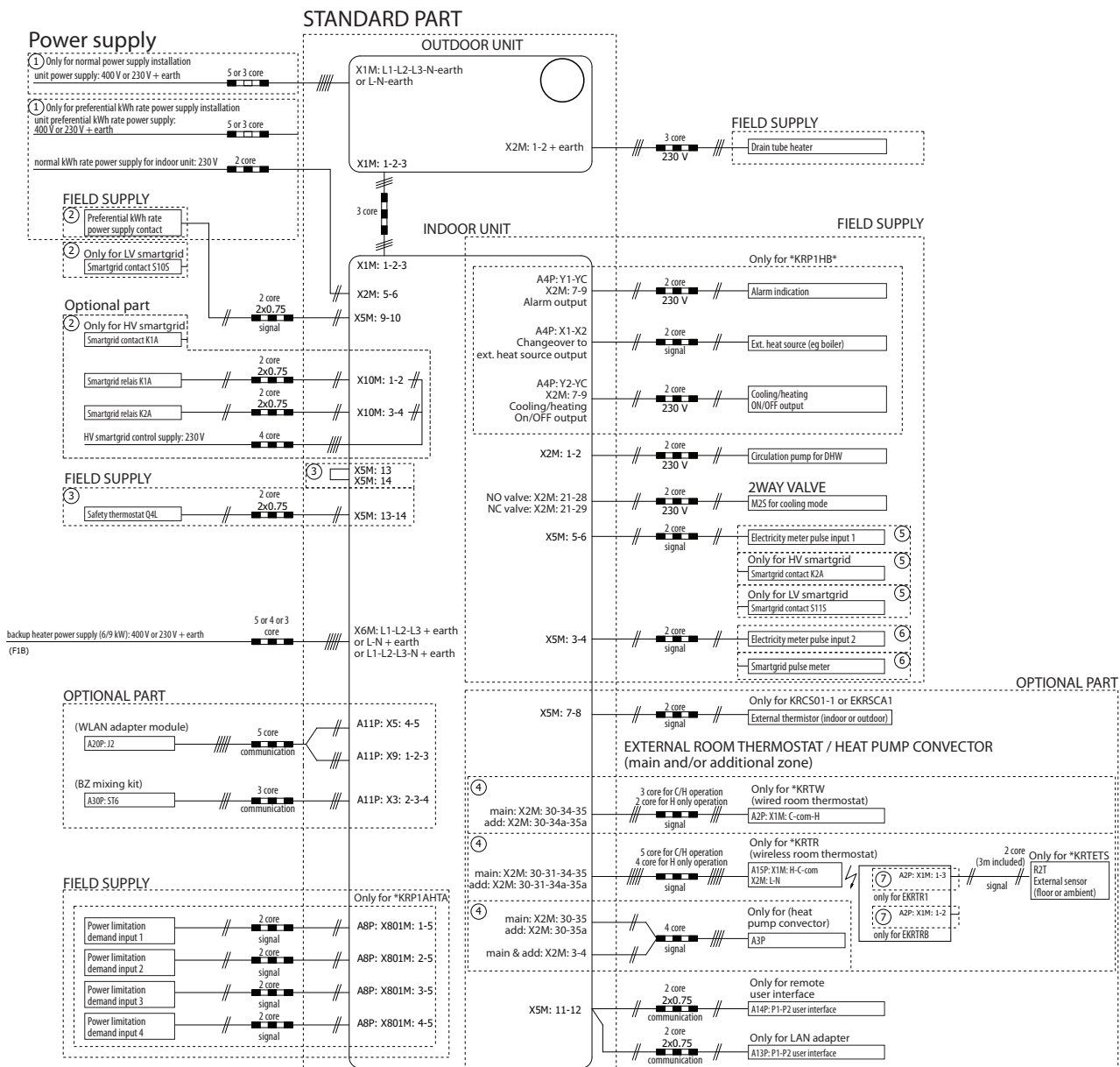

**NOTE**

- In case of signal cable: keep minimum distance to power cables > 5 cm

4D133216C

# 11 Installation

## 11 - 1 Installation Method

ETVH16E6V7  
ETVH16E9W7  
ETVX16E6V7  
ETVX16E9W7

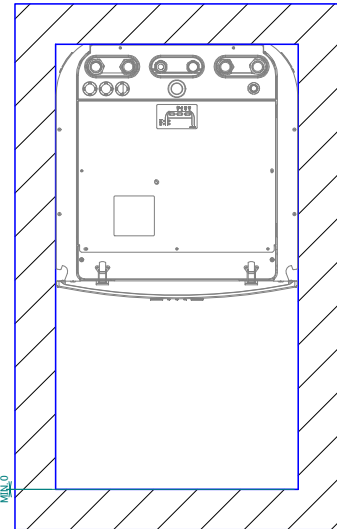
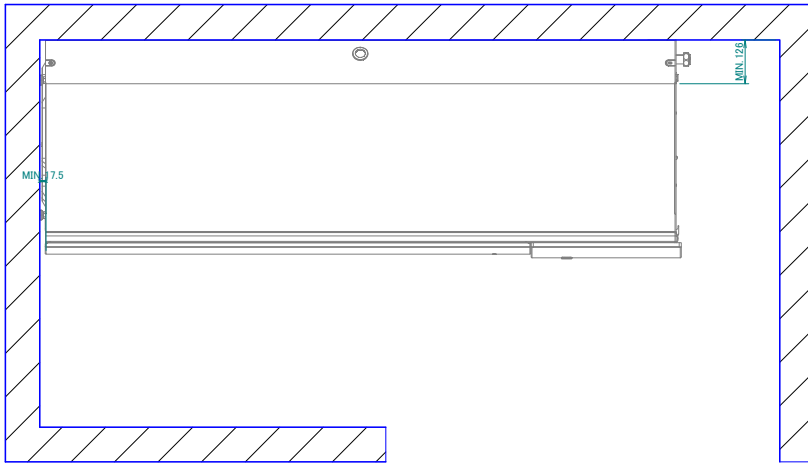

3D121004A

# 12 Operation range

## 12 - 1 Operation Range

12

ETBH16E6V7  
 ETBH16E9W7  
 ETBX16E6V7  
 ETBX16E9W7  
 ETVH16E6V7  
 ETVH16E9W7  
 ETVH16UE6V7  
 ETVX16E6V7  
 ETVX16E9W7  
 ETVZ16E6V7  
 ETVZ16E9W7

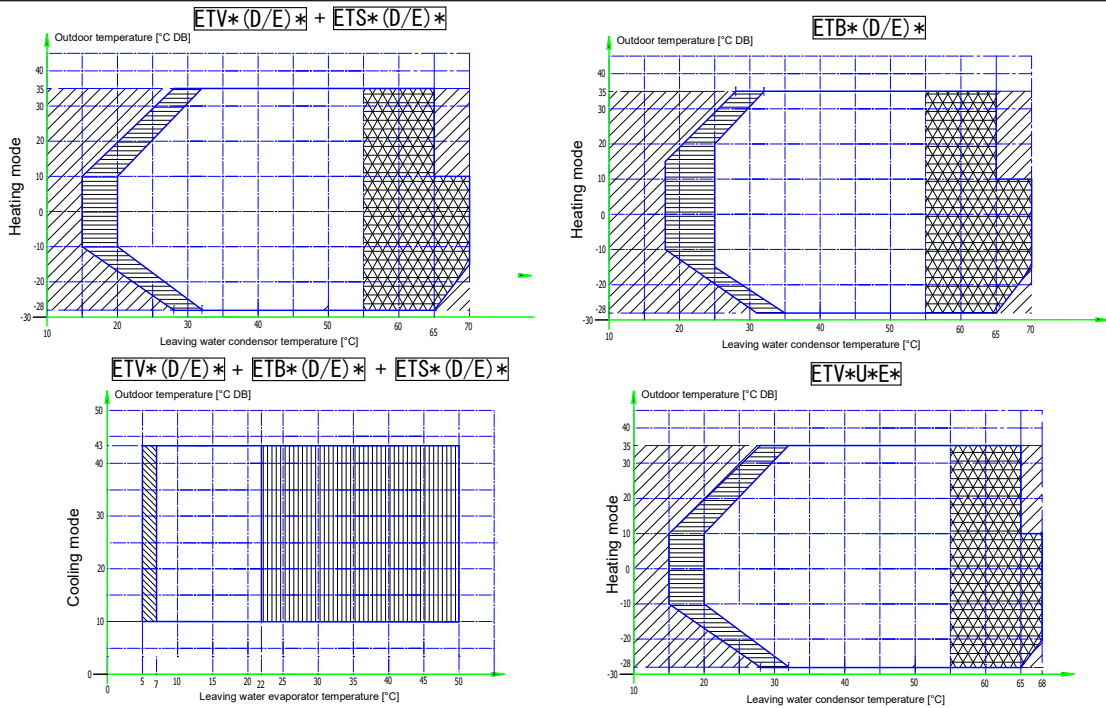

**Legend**

- Backup heater only operation  
No outdoor unit operation
- Outdoor unit operation if setpoint ≥ -20°
- Pull-down area
- Outdoor unit operation if setpoint > 55 °C and ΔT = -10 °C (ΔT = outlet temperature - inlet temperature)
- In case valve kit -AFVALVE1- is part of the system, then the minimum setpoint is -7 °C.

**Remark**  
 In restricted power supply mode, the outdoor unit, booster heater and backup heater can only operate separately.

3D125788C

### Domestic hot water heating mode

ETBH16E6V7  
 ETBH16E9W7  
 ETBX16E6V7  
 ETBX16E9W7  
 ETVH16E6V7  
 ETVH16E9W7  
 ETVH16UE6V7  
 ETVX16E6V7  
 ETVX16E9W7  
 ETVZ16E6V7  
 ETVZ16E9W7

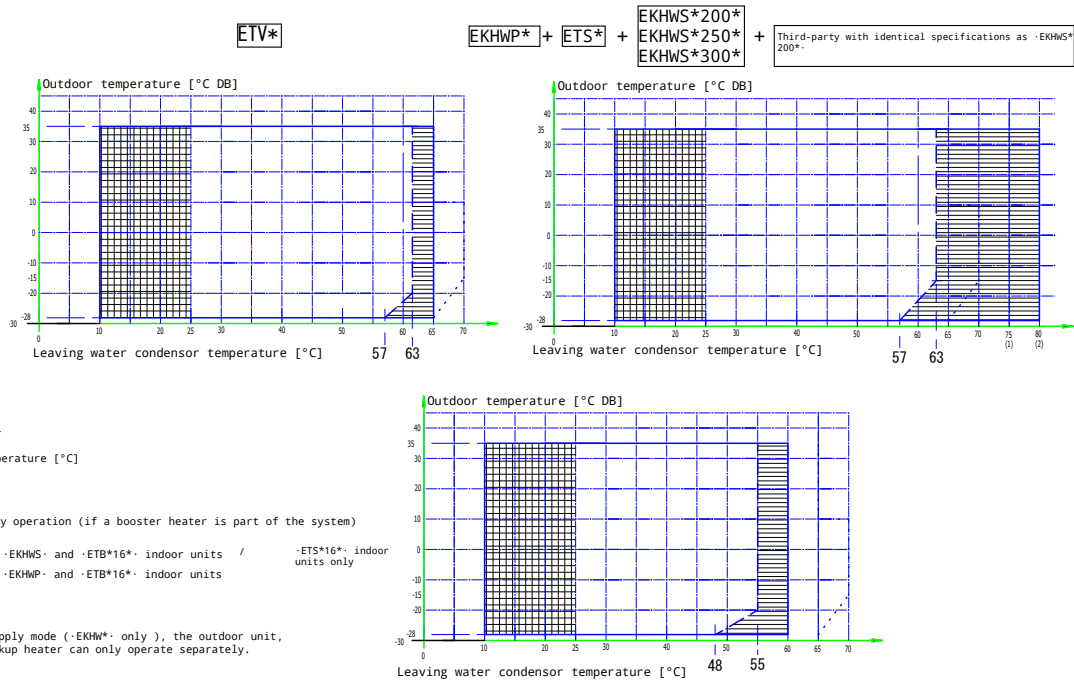

**Legend**

- Setpoint [°C]  
Domestic hot water
  - Leaving water temperature [°C]
  - Pull-up area
  - Booster heater only operation (if a booster heater is part of the system)
- (1) Combination of -EKHWS- and -ETB\*16\*- indoor units / -ETS\*16\*- indoor units only  
 (2) Combination of -EKHWP- and -ETB\*16\*- indoor units

**Remark**  
 1. In restricted power supply mode (-EKHW\* only), the outdoor unit, booster heater and backup heater can only operate separately.

2 Third-party with identical specifications as -EKHWS\*150\*-  
 . Coil surface > 1.05-m<sup>2</sup>  
 Tank thermostat: top part of heat pump coil. Small overlap.

3 Third-party with identical specifications as -EKHWS\*200\*-  
 . Coil surface > 1.8-m<sup>2</sup>  
 Tank thermostat: top part of heat pump coil. Small overlap.

EKHWS\*150\* + Third-party with identical specifications as -EKHWS\*150\*

3D125789C

# 13 Hydraulic performance

## 13 - 1 Static Pressure Drop Unit

ETVH16E6V7 / ETVH16UE6V7 / ETVH16E9W7 / ETVX16E6V7 / ETVX16E9W7

Notes

1. Selecting a flow outside the operating area can damage the unit or cause the unit to malfunction.

See also the minimum and maximum allowed water flow range in the technical specifications.

2. Water quality must be according to EU directive 98/83 EC.

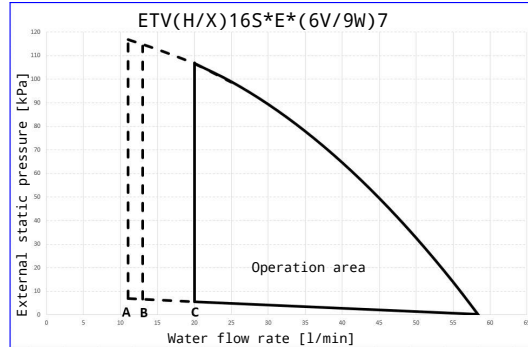
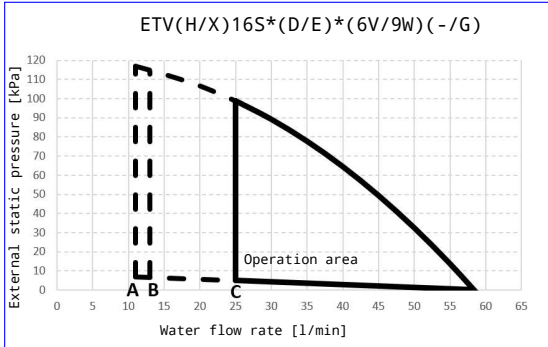

- A Minimum water flow rate during normal operation
- B Minimum water flow rate during backup heater operation
- C Minimum water flow rate during defrost operation

Operation area is extended to lower flow rates only in case the unit operates with heat pump only. (Not in startup, no BUH operation, no defrost operation.)

See dashed lines

4D124954C

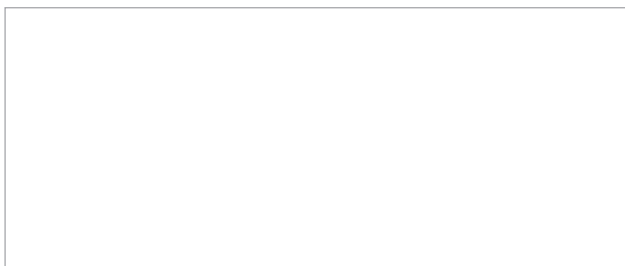

EEDEN22A

12/2022



The present leaflet is drawn up by way of information only and does not constitute an offer binding upon Daikin Europe N.V. Daikin Europe N.V. has compiled the content of this leaflet to the best of its knowledge. No express or implied warranty is given for the completeness, accuracy, reliability or fitness for particular purpose of its content and the products and services presented therein. Specifications are subject to change without prior notice. Daikin Europe N.V. explicitly rejects any liability for any direct or indirect damage, in the broadest sense, arising from or related to the use and/or interpretation of this leaflet. All content is copyrighted by Daikin Europe N.V.