

EA122 Automatic Air Vent

WITH INTEGRAL SHUTOFF AND LEAK PROTECTION

PRODUCT DATA

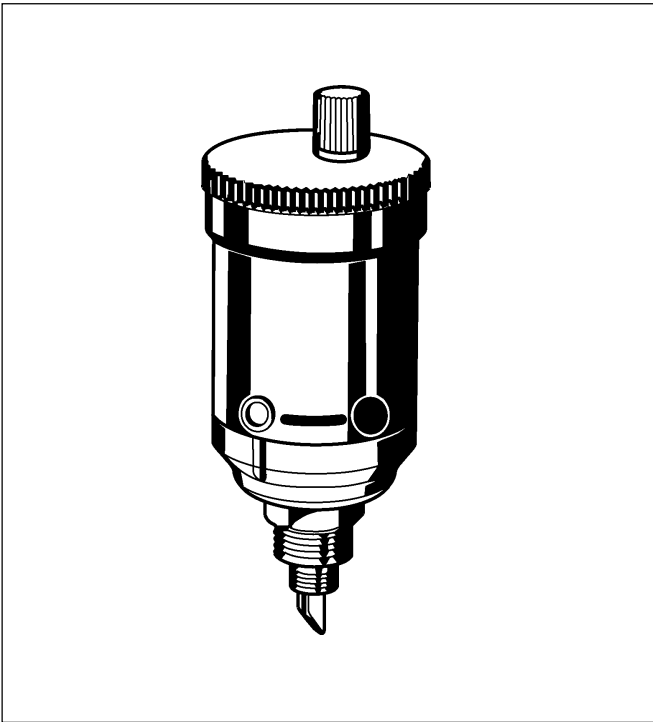

Application

The EA122 Automatic Air Vent is a reliable venting device and is suitable for venting of air or gas from heating systems or heat process installations.

Features

- Integral shutoff facility
- Expanding discs prevent leakage
- Integral vacuum break
- Cleaning and exchange of the seal and inner components can be carried out without draining the system

Range of Application

Hot water heating systems, radiators, wall and ceiling-mounted air heaters, air collection vessels, pipe circuits, boilers and air separators.

Specifications

Operating temperature	max. 110°C (230°F)
Operating pressure	max. 6 bar (87 P.S.I.)
Connection sizes	R 1/8" + 3/8" and R 1/2" or optionally R 1/4" + 3/4"

Design

- The automatic air vent comprises:
- Connection components
- Integral vacuum break
- Float housing
- Lid
- Float
- Seal cap with expanding discs
- Valve seat seals

Materials

- Brass connection components
- High grade, heat resistant synthetic material float housing
- High grade, heat resistant synthetic material lid
- High grade, heat resistant synthetic material float
- Heat resistant elastomer seal components

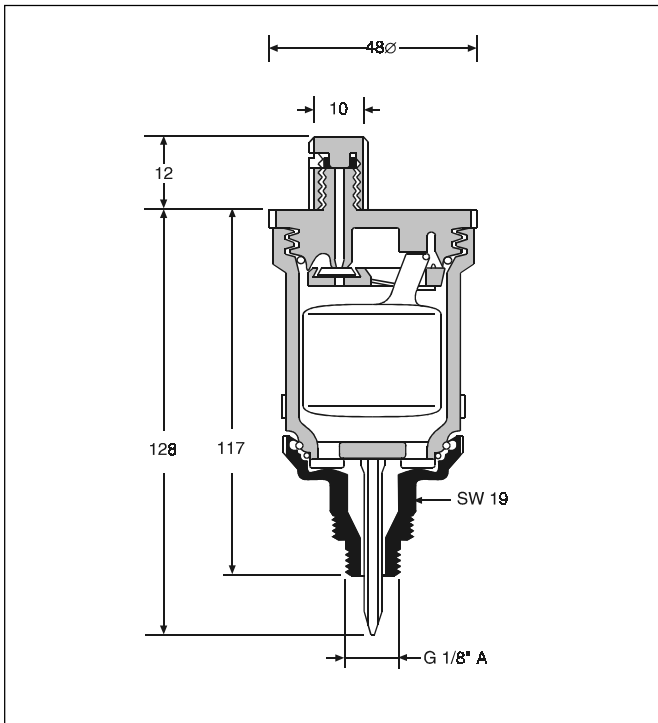

Function

Inside the automatic air vent there is a float which operates a lever according to the water level. When there is no water in the housing, then the float opens the valve. Air can therefore be vented from the heating system during filling. When the heating system has been filled, the inflowing water closes the valve and the vent is shut off. Water usually contains oxygen which bubbles off during operation of the system and collects at the highest point. The automatic air vent must therefore be fitted at the air collection position (highest point on a boiler or pipework circuit). The closing force of the float valve is very small and therefore water-borne dirt can prevent the valve fully closing which results in the valve dripping slightly. Expanding discs are built into the valve to prevent this dripping occurring. These discs expand when wet and then shut off a secondary valve, thereby preventing leakage.

Versions

EA122-AA = Connection sizes R 1/8" + 3/8"
 EA122-BA = Connection sizes R 1/4" + 3/8"
 EA122-Z = Special versions on request

Service Parts

Lid complete with float Order-No. 0900577
 Leak protection discs complete (pack of 5) Order-No. 0900761

Venting Capacity

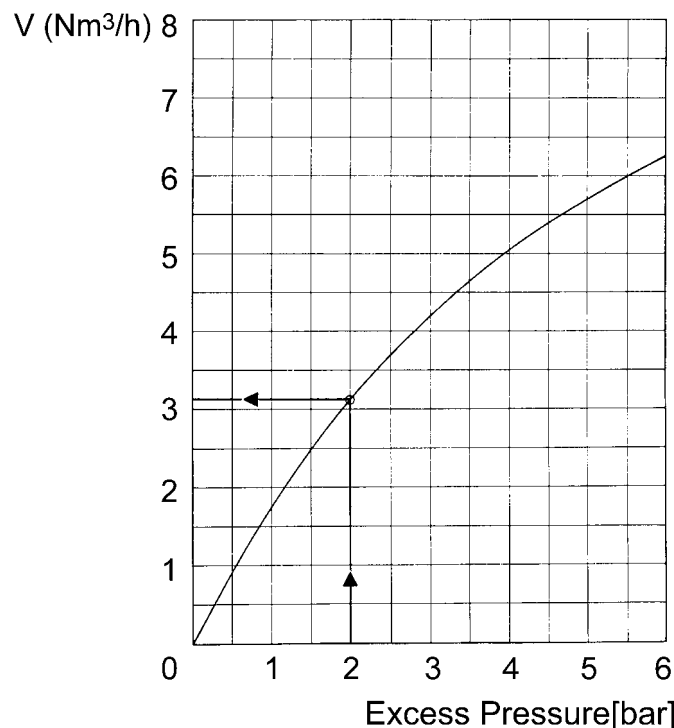

Honeywell

Home and Building Control

Honeywell AG
 Zu den Ruhrwiesen 3
 D-59755 Arnsberg-Neheim

Phone: (49) 2932 9880
 Fax: (49) 2932 988239
 mng@honeywell.com

<http://europe.hbc.honeywell.com>