

## Frontmontert torsjon

75mm/115mm  
40mm panel

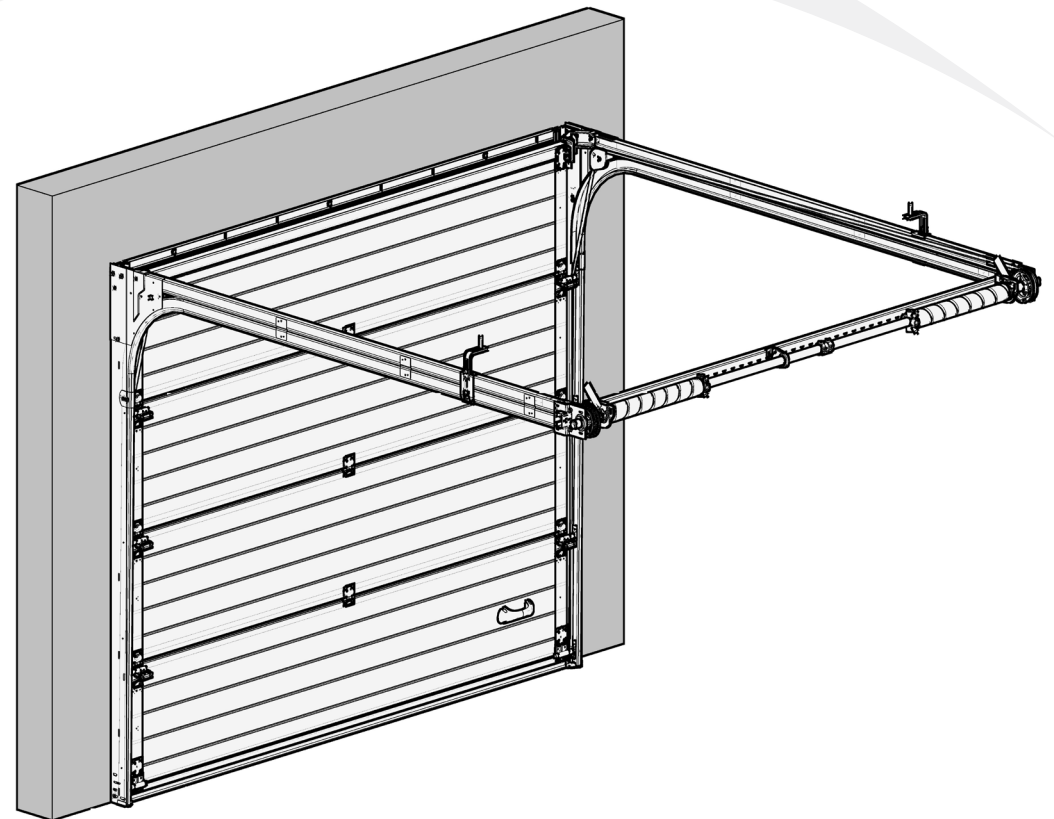

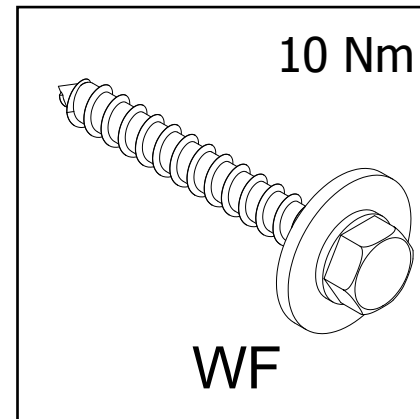

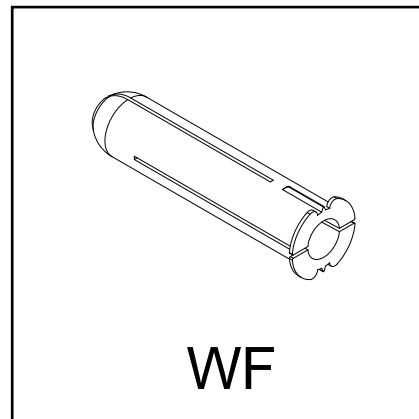
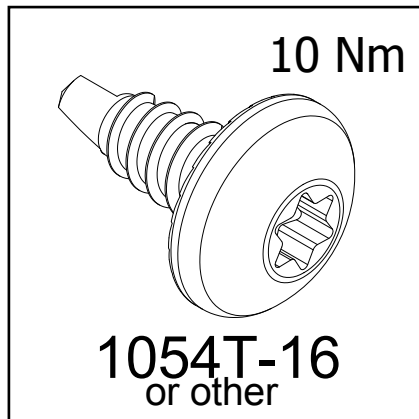
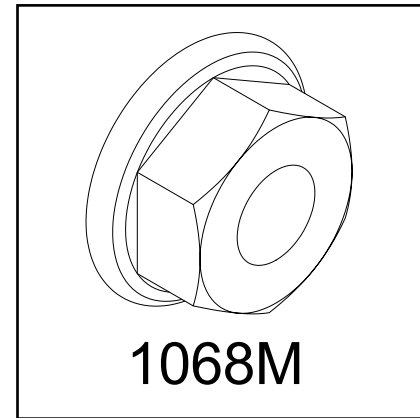
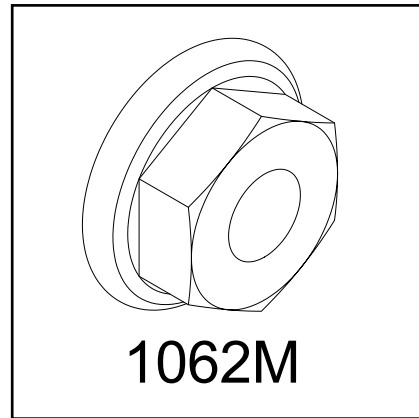
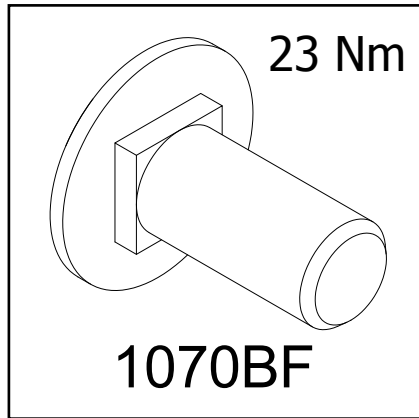
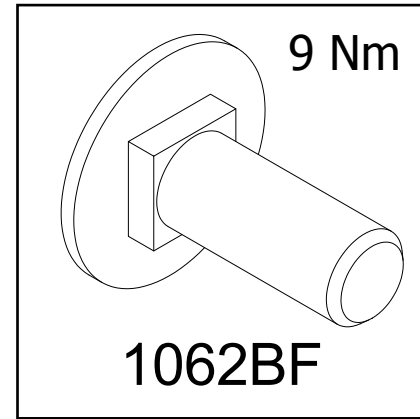
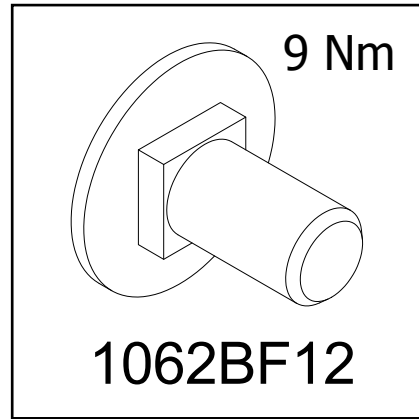
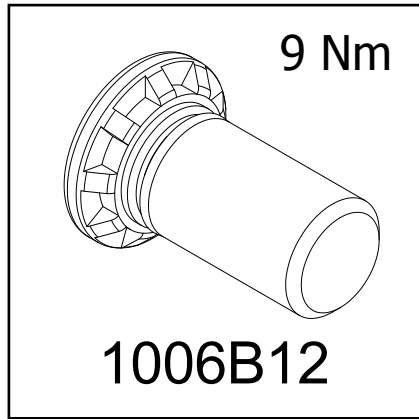
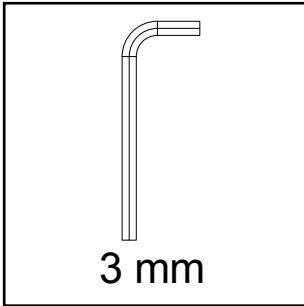
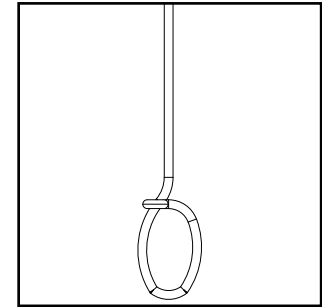
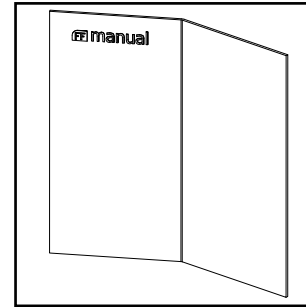
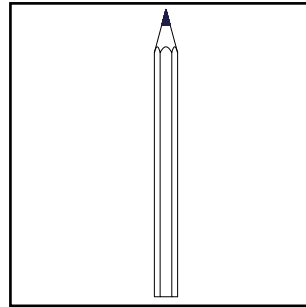
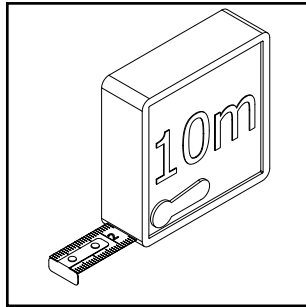
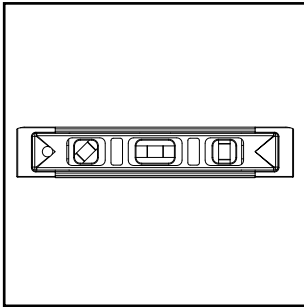

3 mm

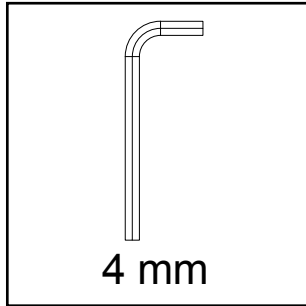

4 mm

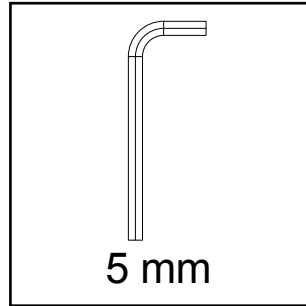

5 mm

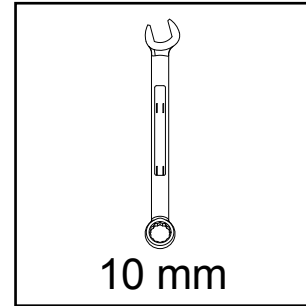

10 mm

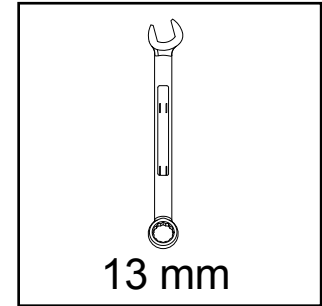

13 mm

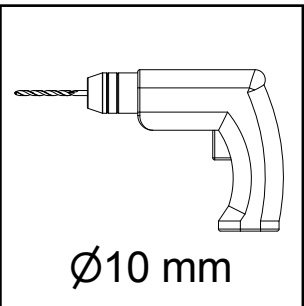

Ø10 mm

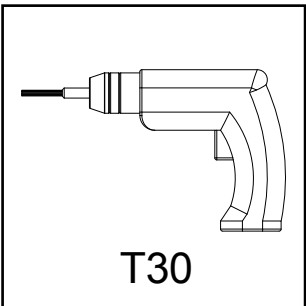

T30

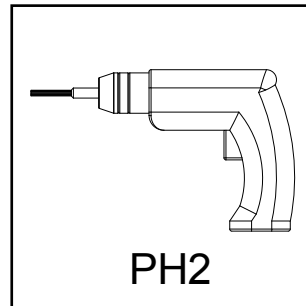

PH2

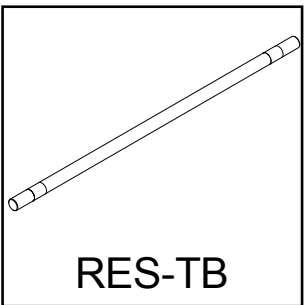
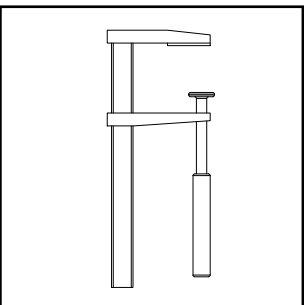
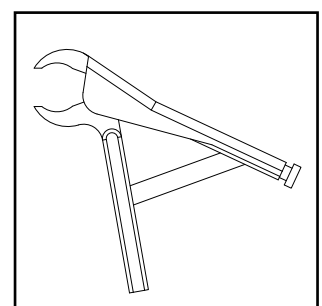
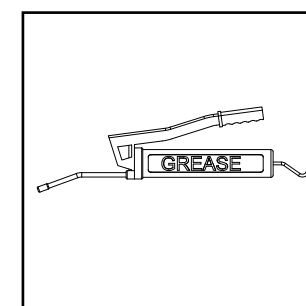

RES-TB

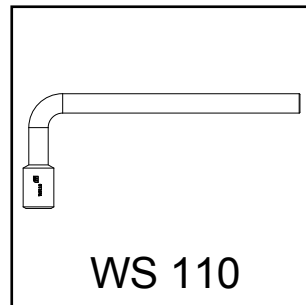

WS 110



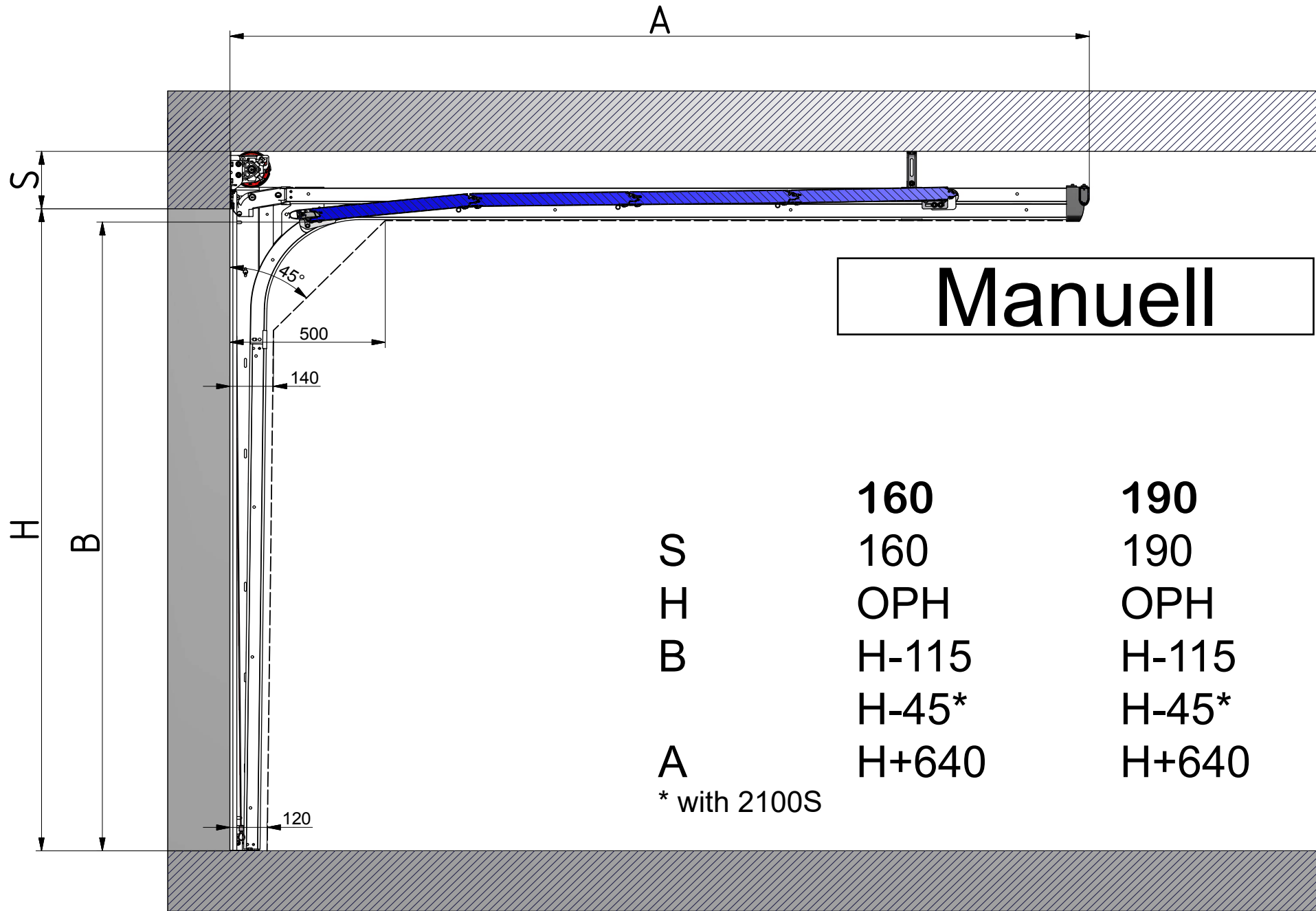

**Manuell**

	<b>160</b>	<b>190</b>
S	160	190
H	OPH	OPH
B	H-115	H-115
	H-45*	H-45*
A	H+640	H+640
	* with 2100S	

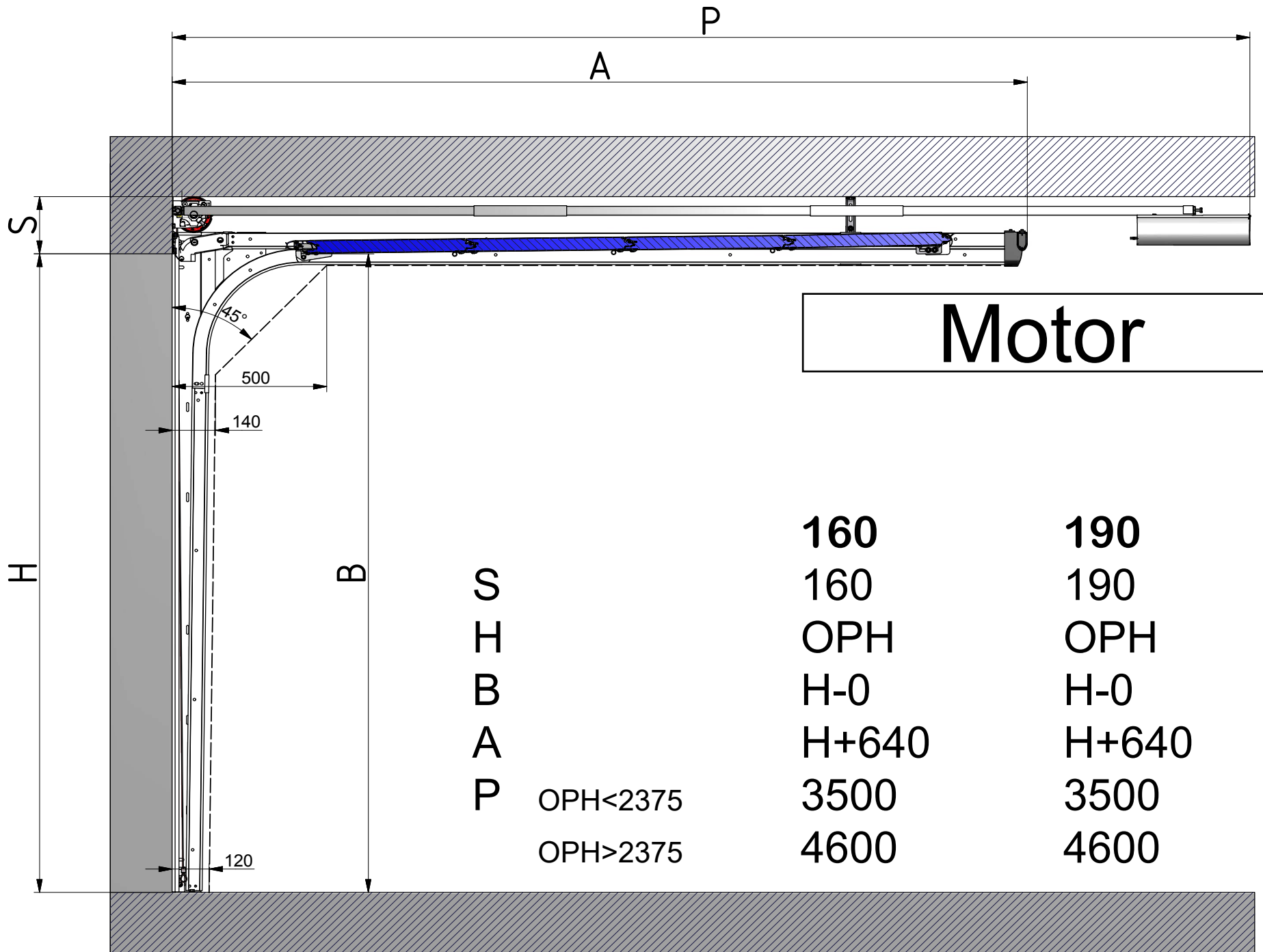

**Motor**

<b>S</b>	<b>160</b>	<b>190</b>
<b>H</b>	<b>160</b>	<b>190</b>
<b>B</b>	<b>OPH</b>	<b>OPH</b>
<b>A</b>	<b>H-0</b>	<b>H-0</b>
<b>P</b>	<b>H+640</b>	<b>H+640</b>
	<b>OPH&lt;2375</b>	<b>3500</b>
	<b>OPH&gt;2375</b>	<b>4600</b>

Kontroller at monterings-  
overflaten er rett og i vater

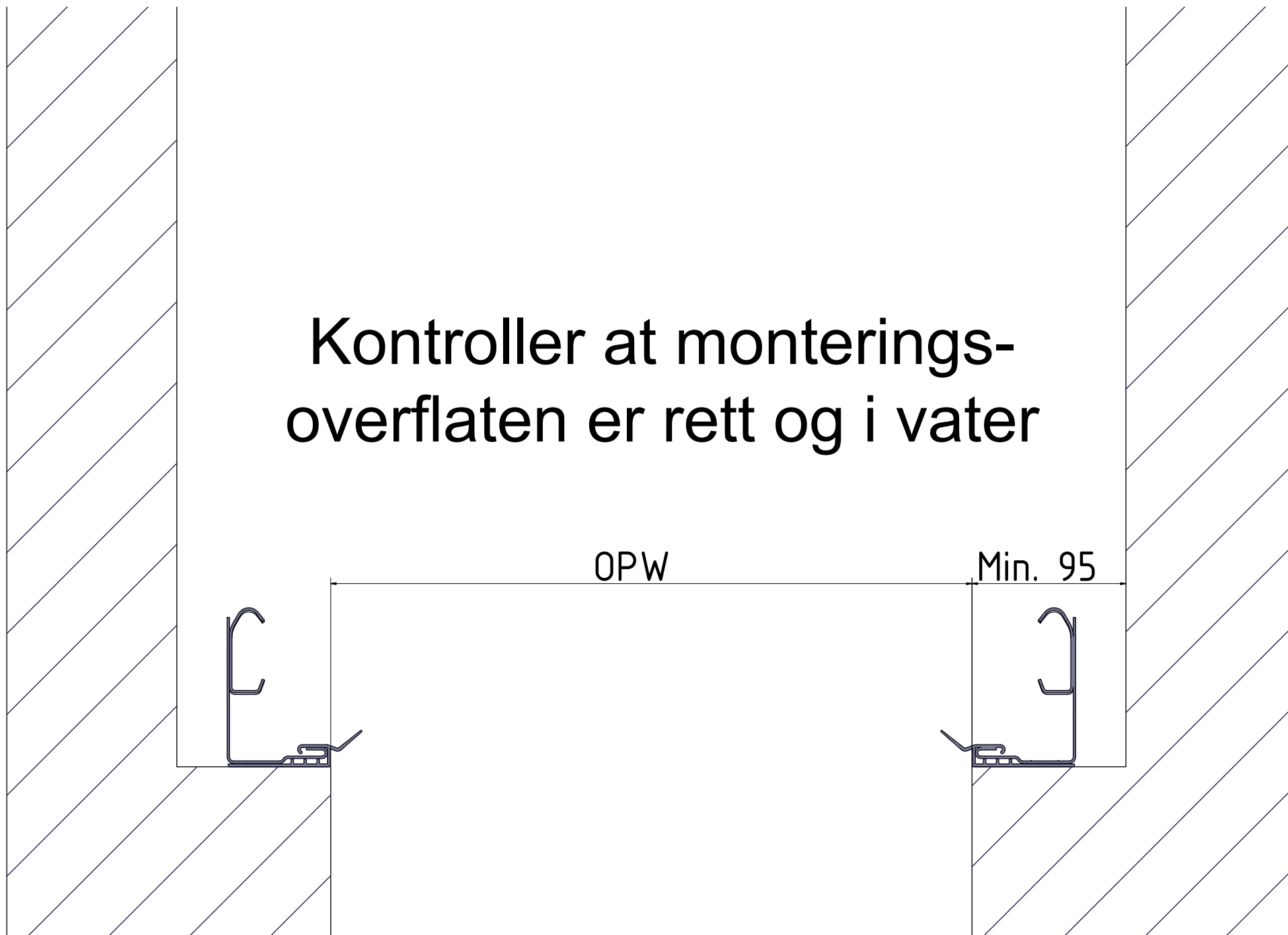

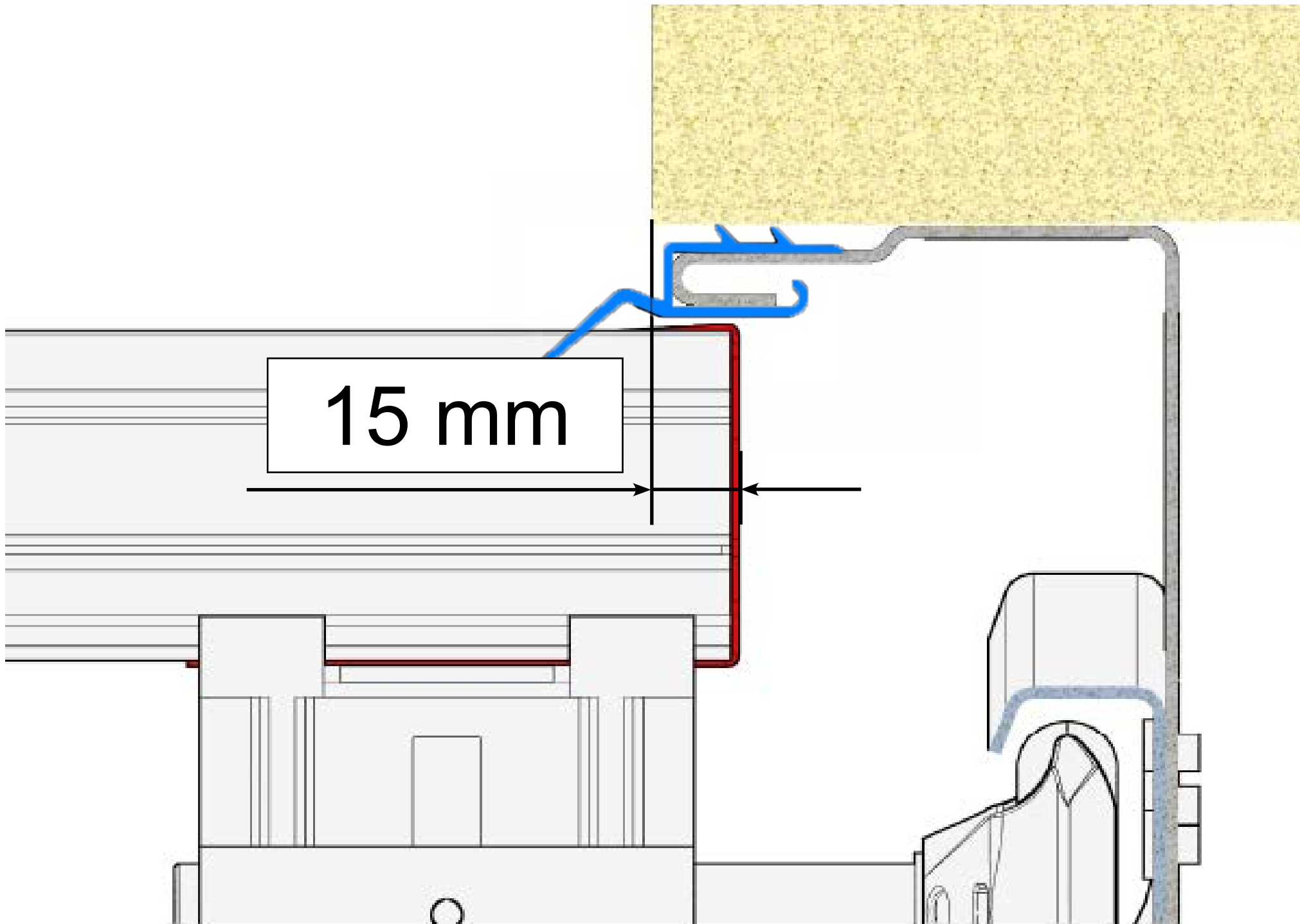

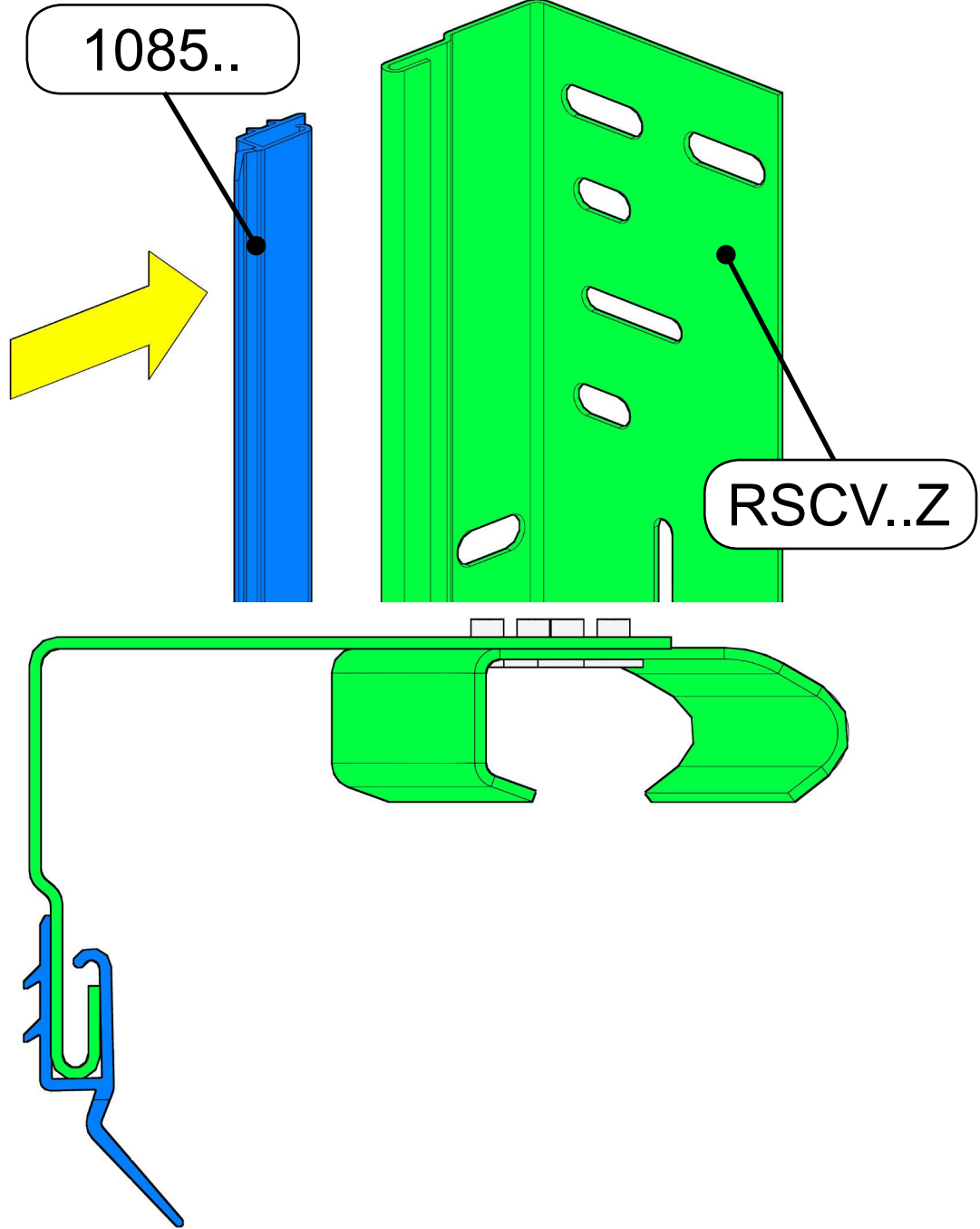
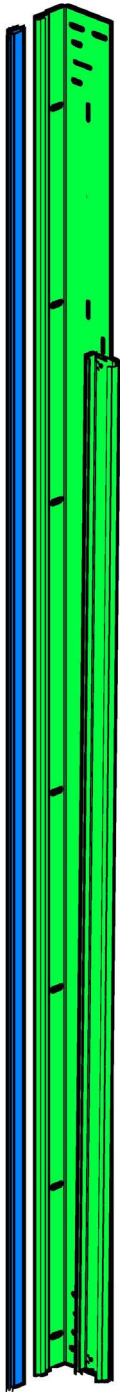



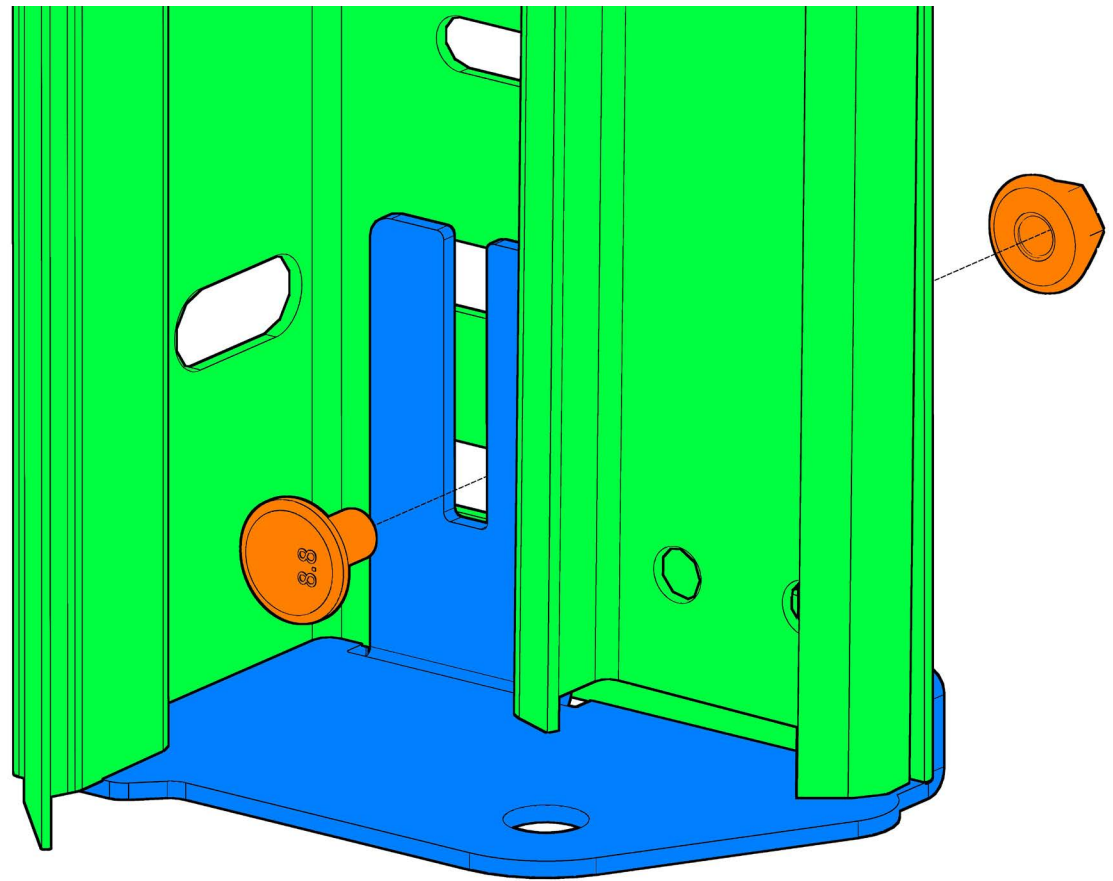
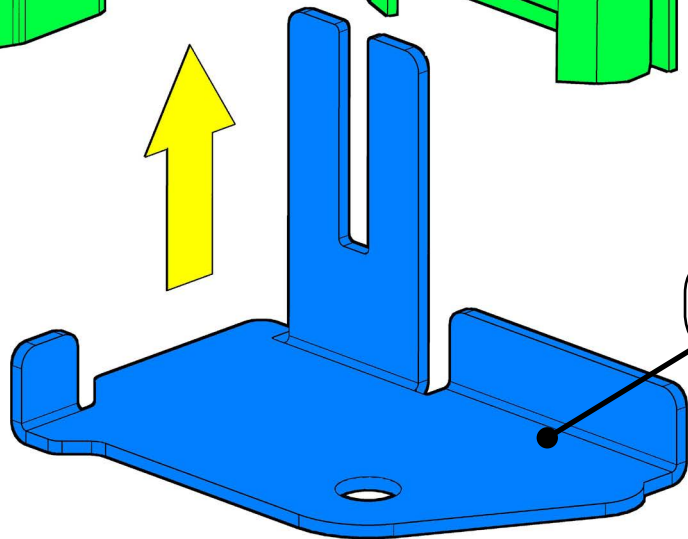
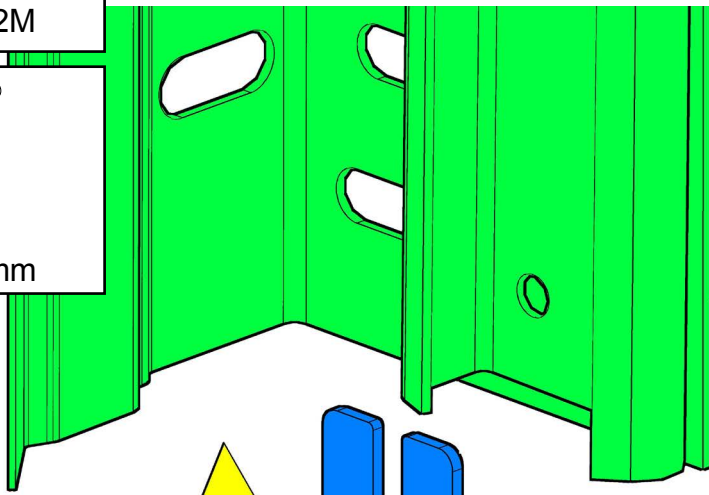
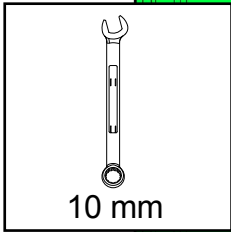
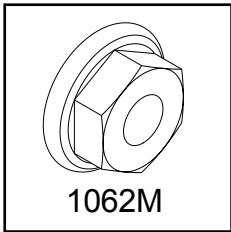
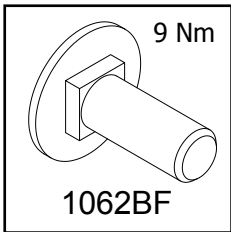

**OPTION**

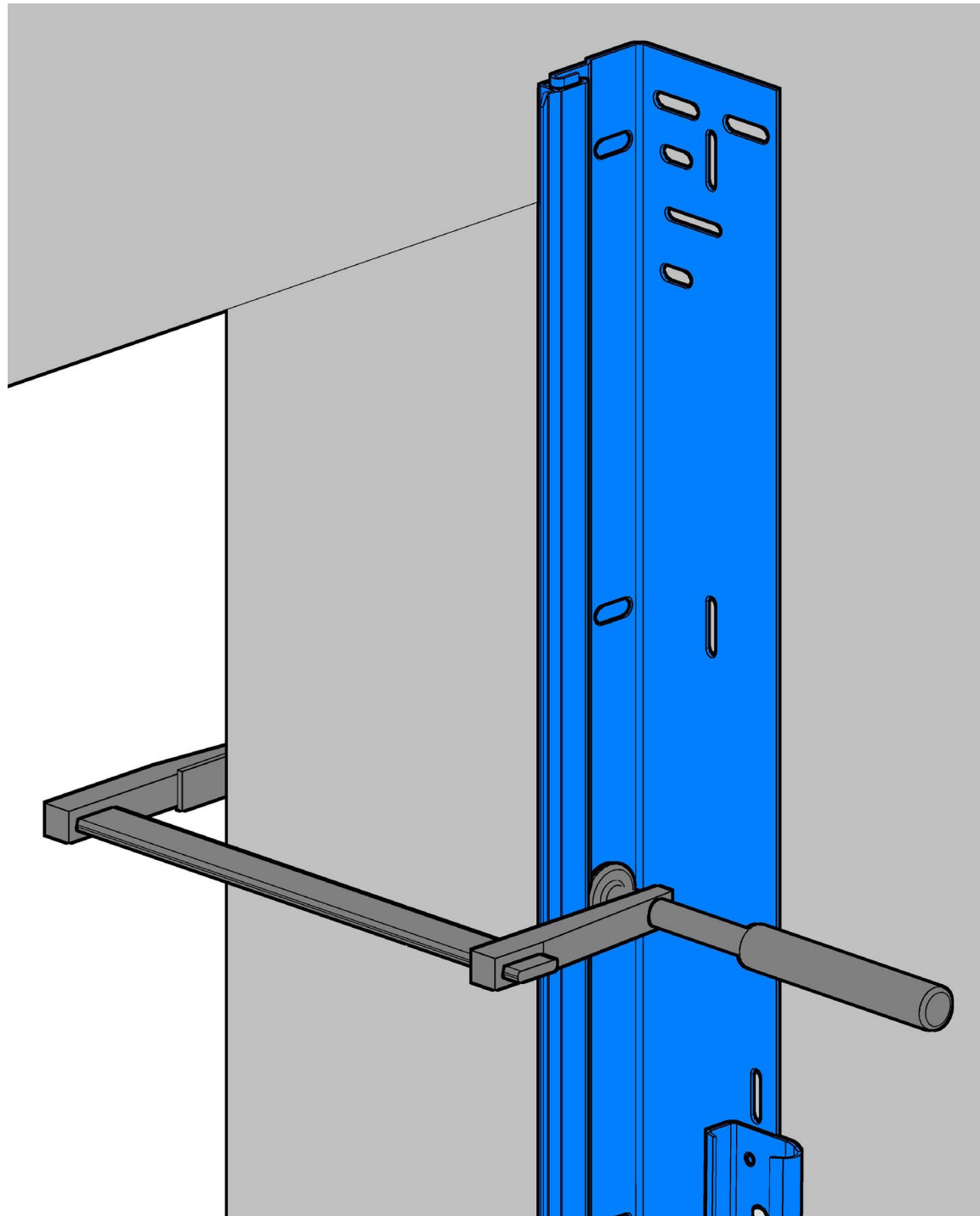
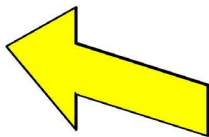
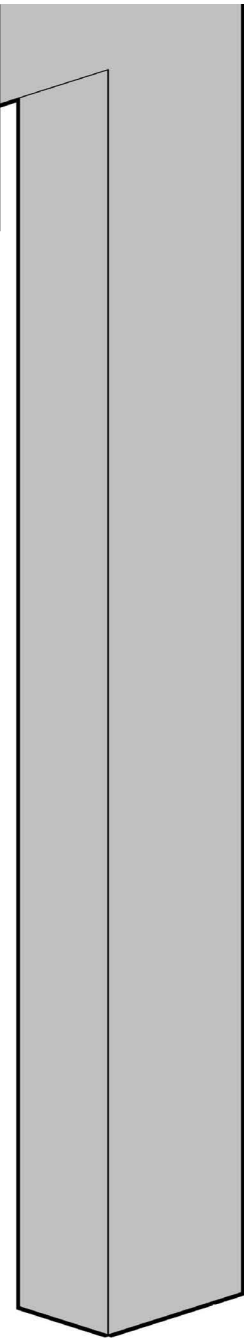
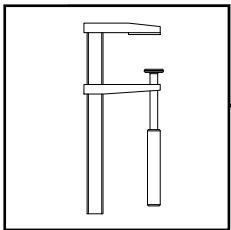

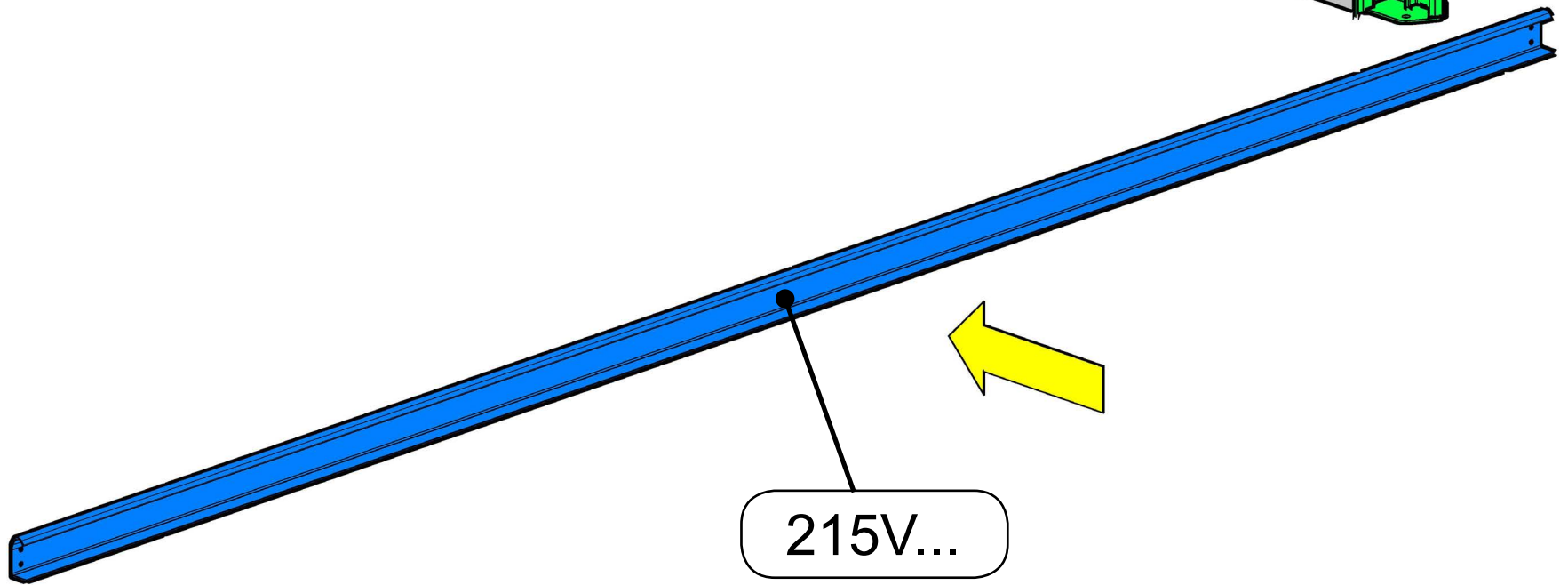
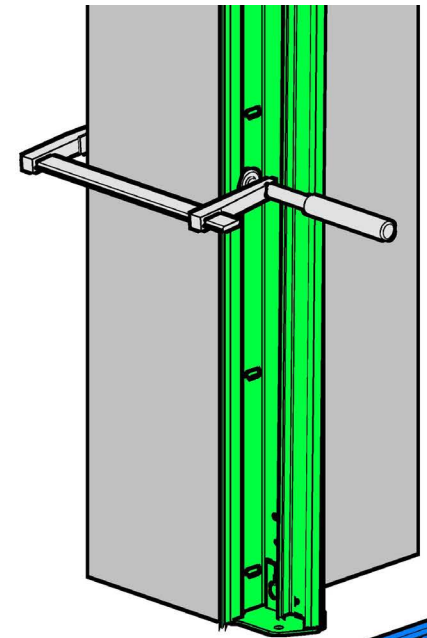
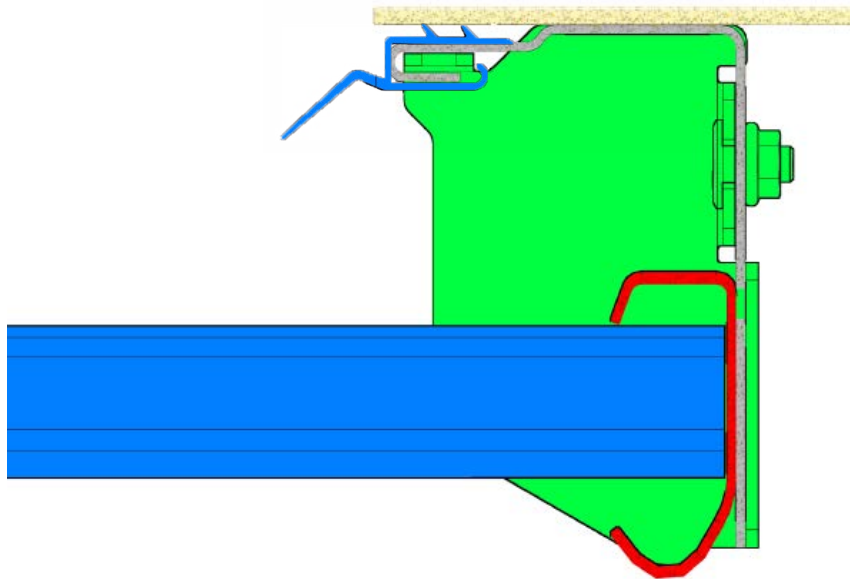
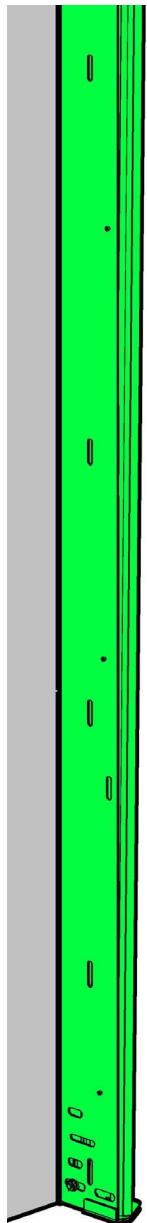

215V...

$$L = \text{Lysåpning} + 123\text{mm}$$

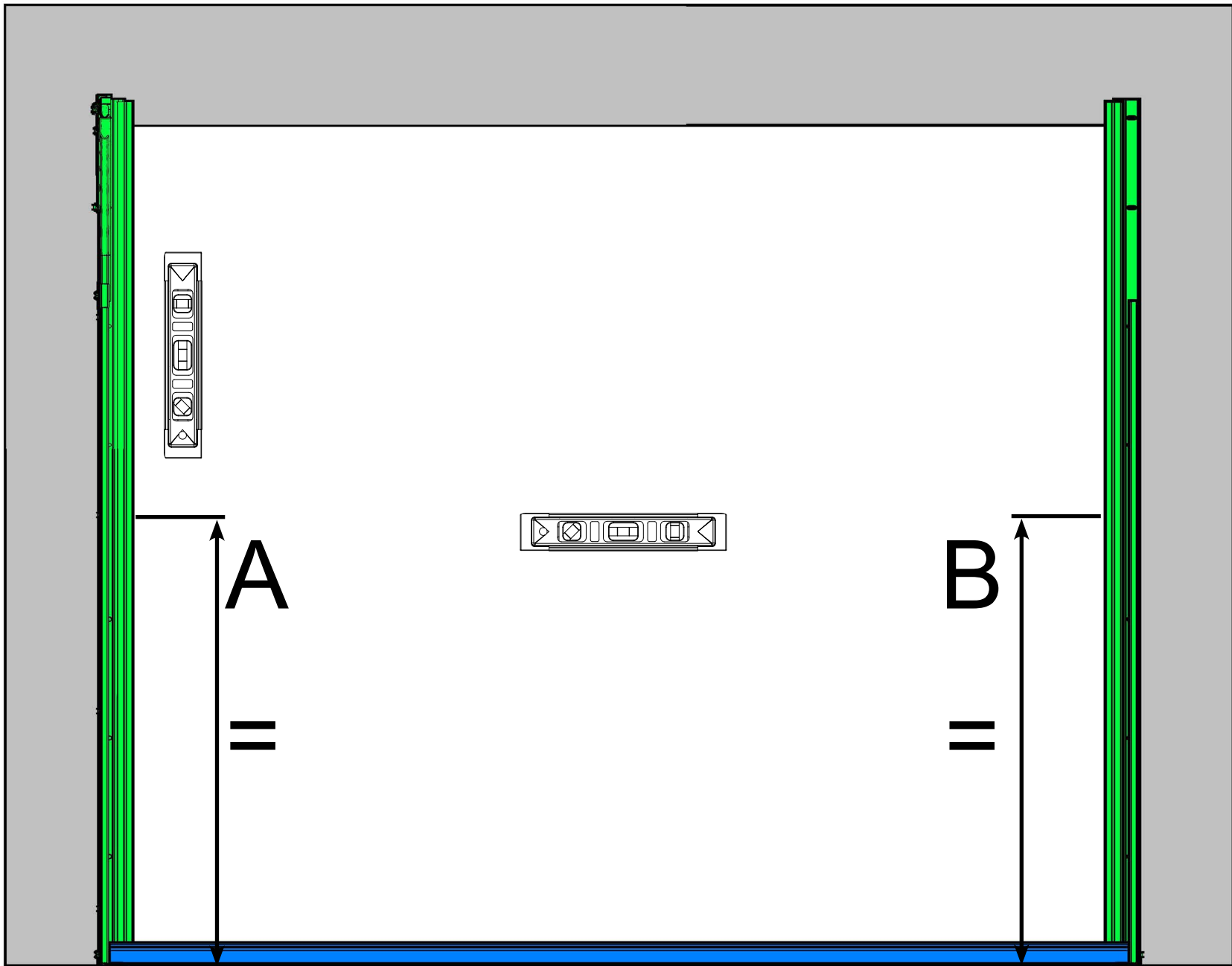
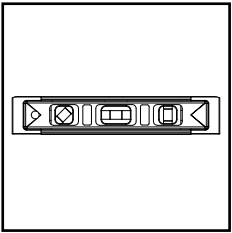

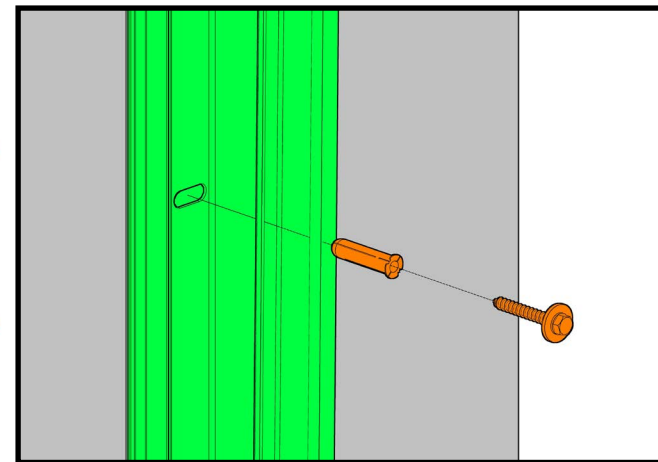
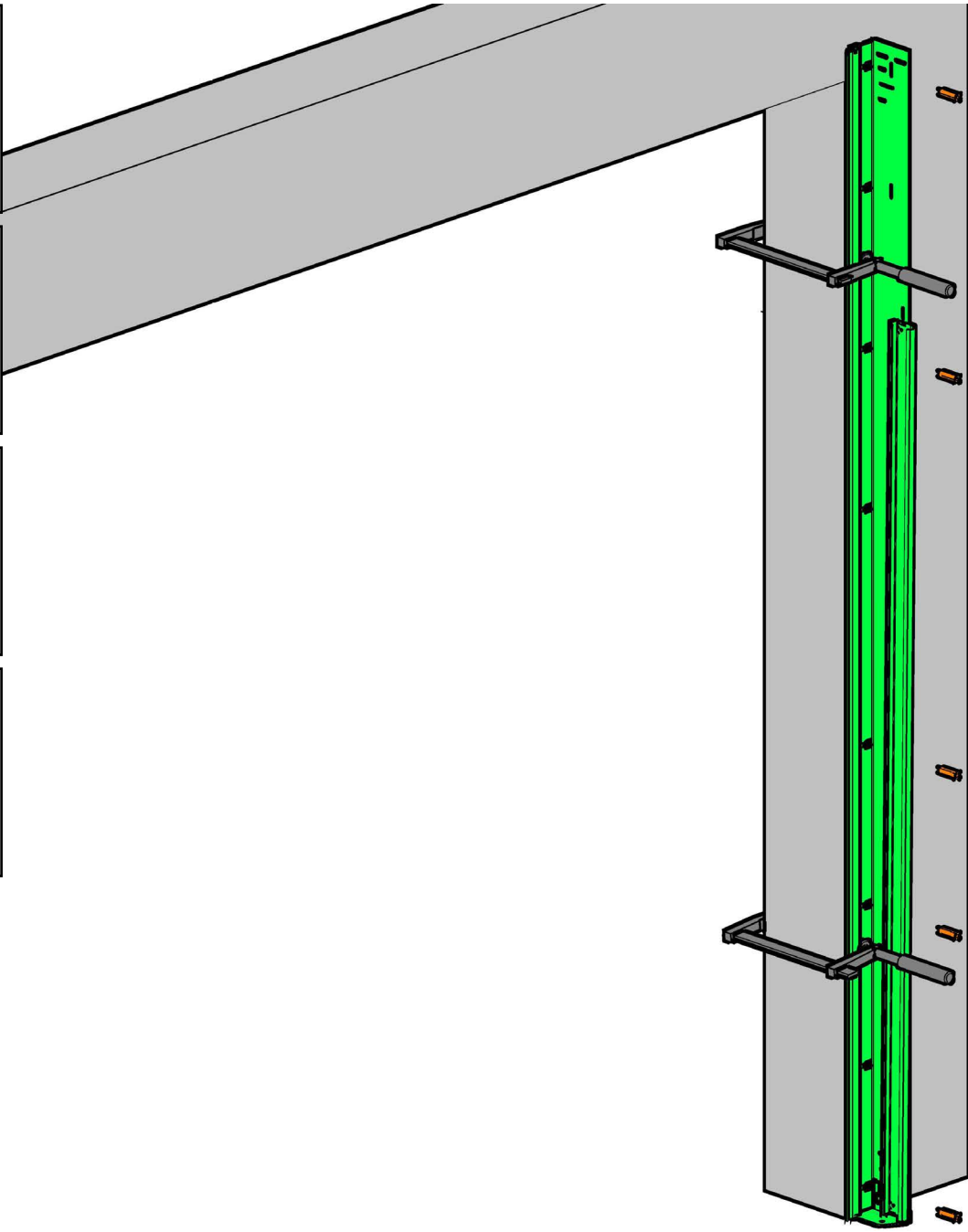
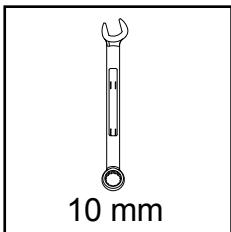
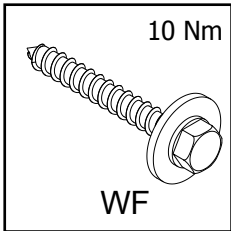
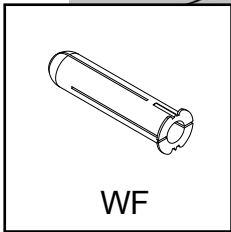
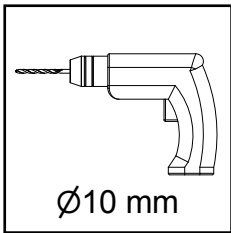

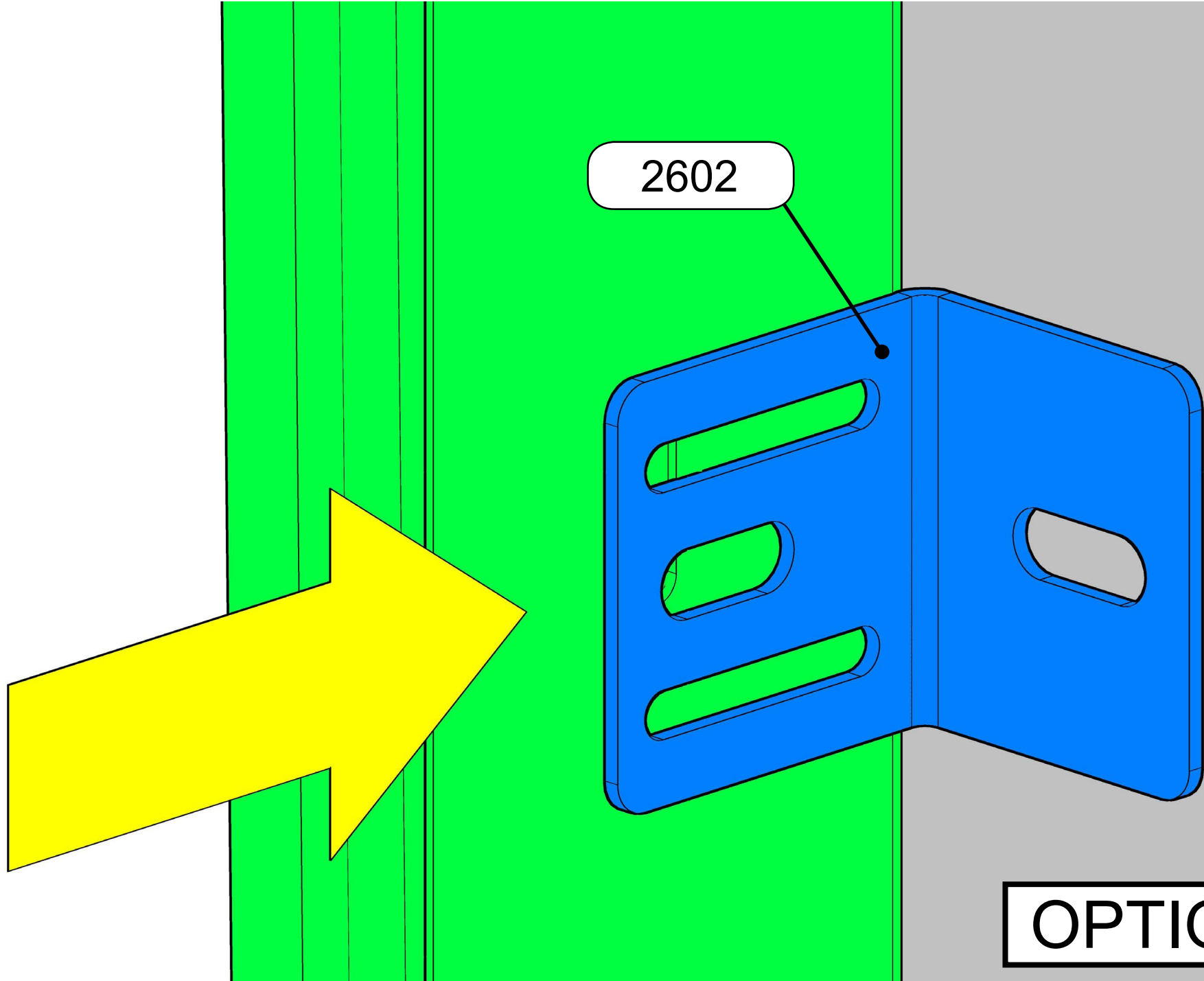

2602

OPTION

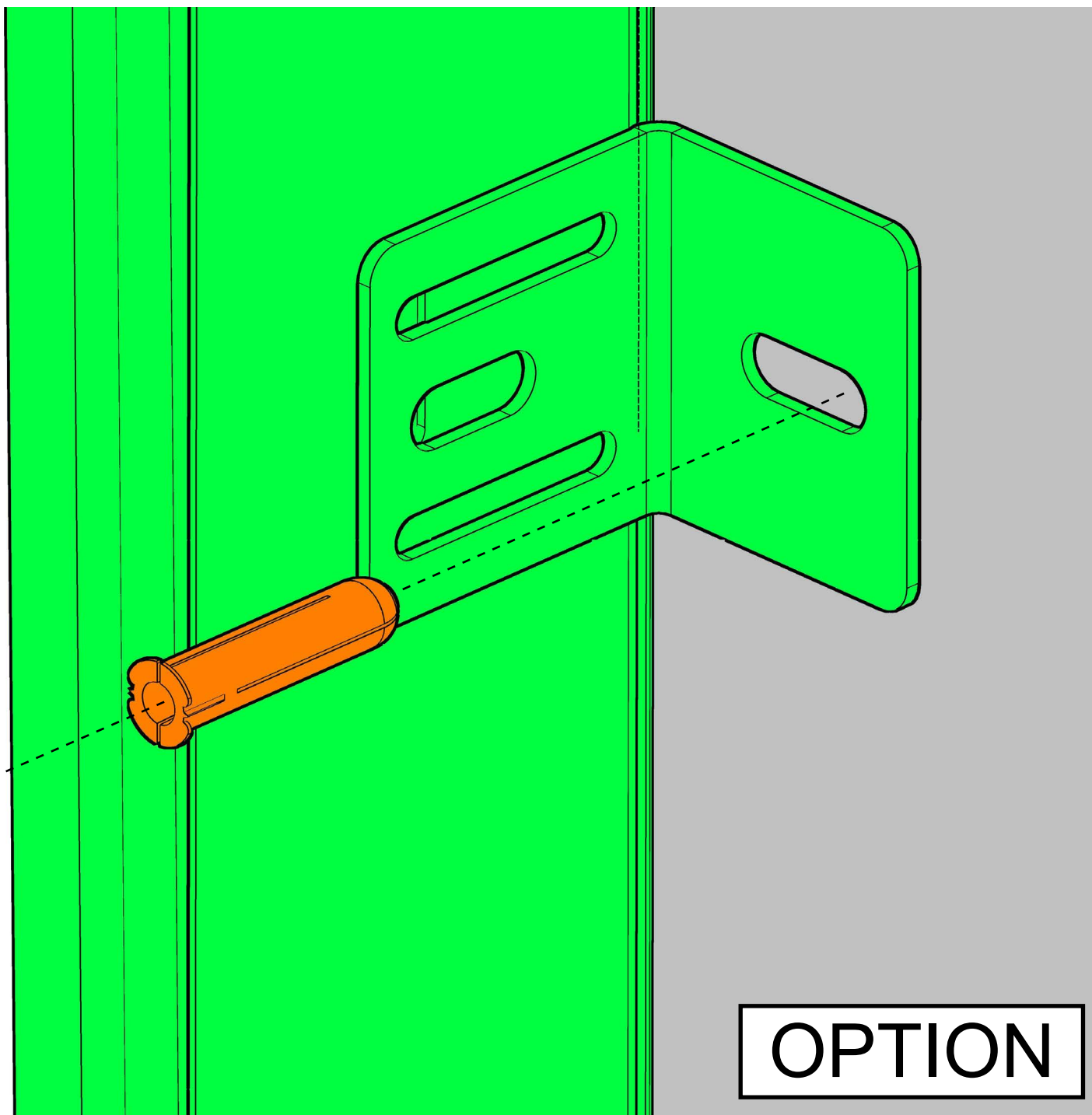
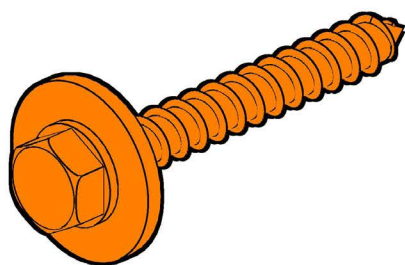
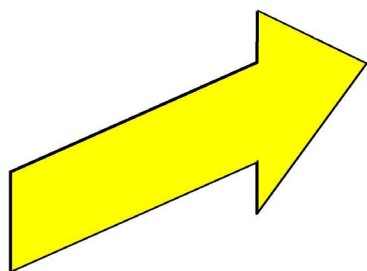
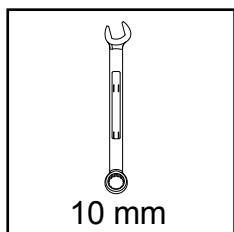
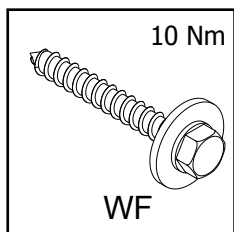
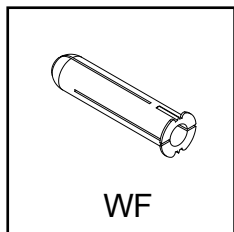
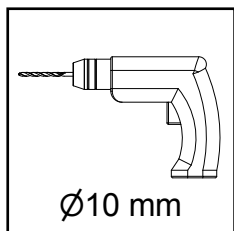

OPTION

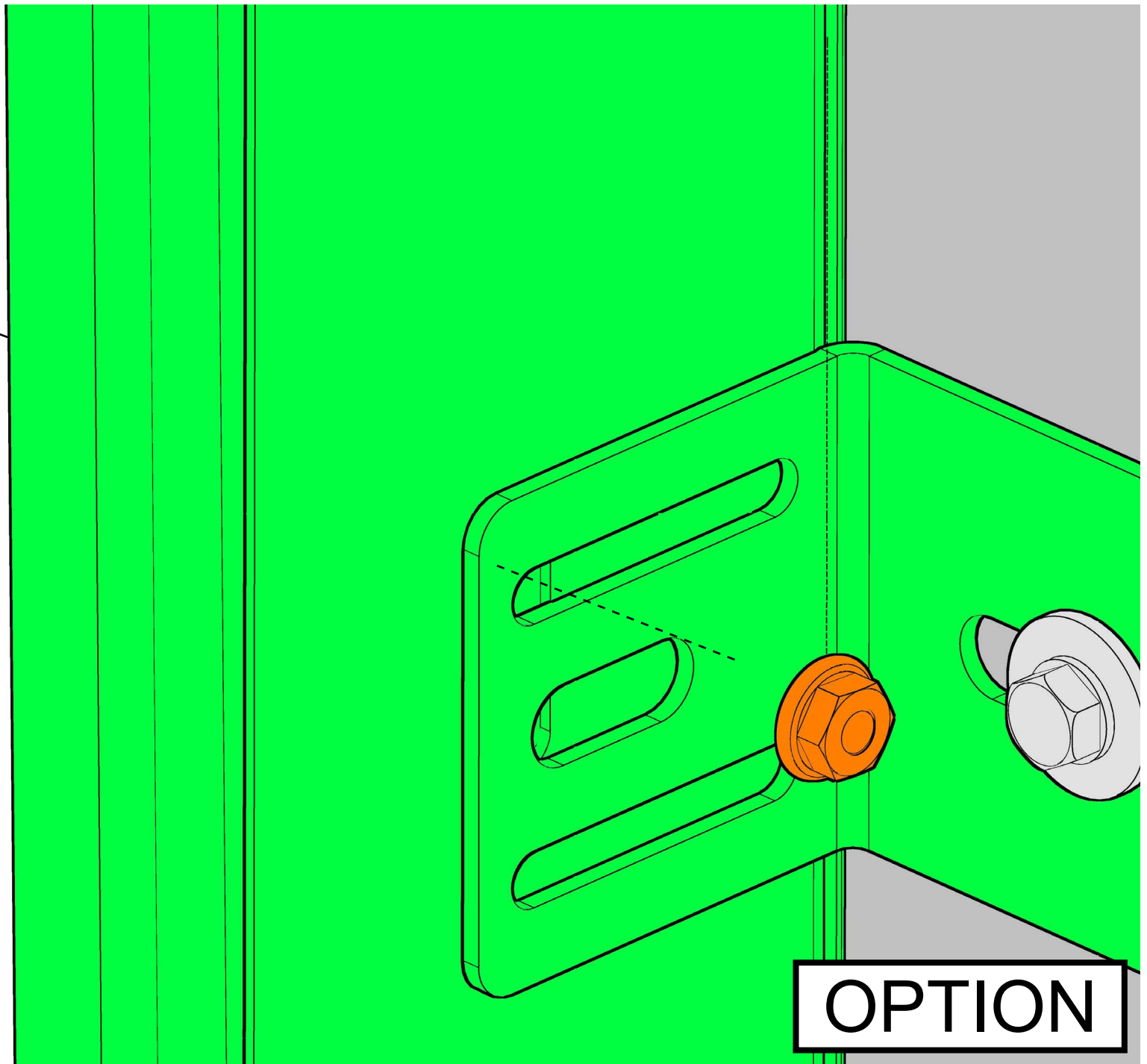
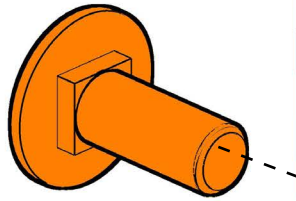
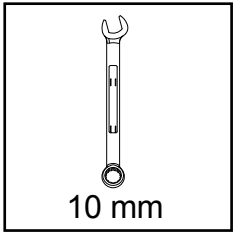
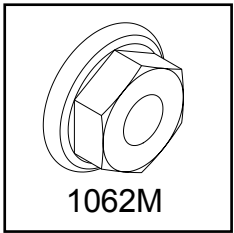
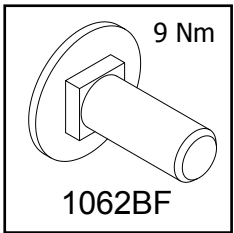

**OPTION**



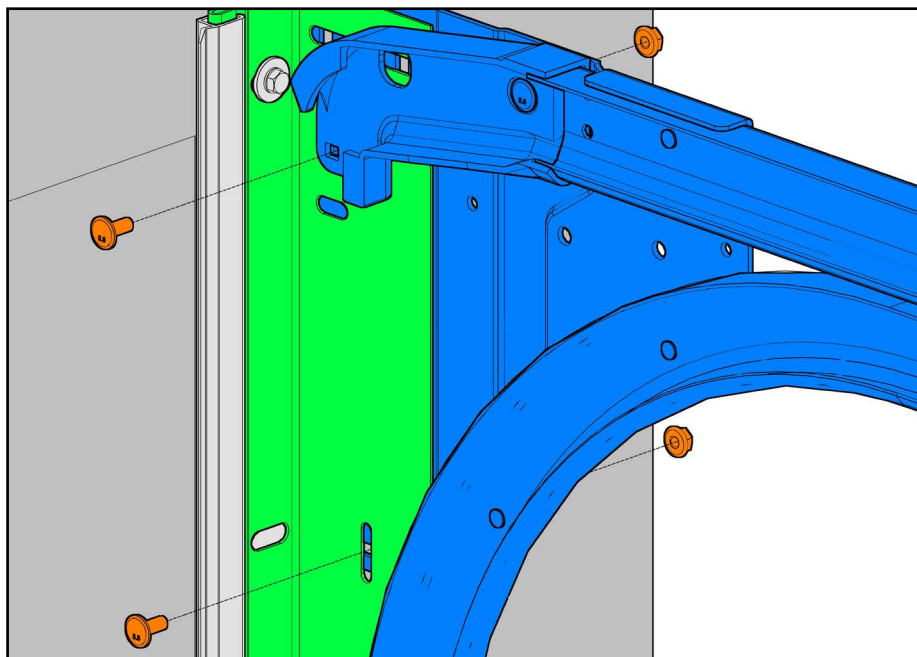
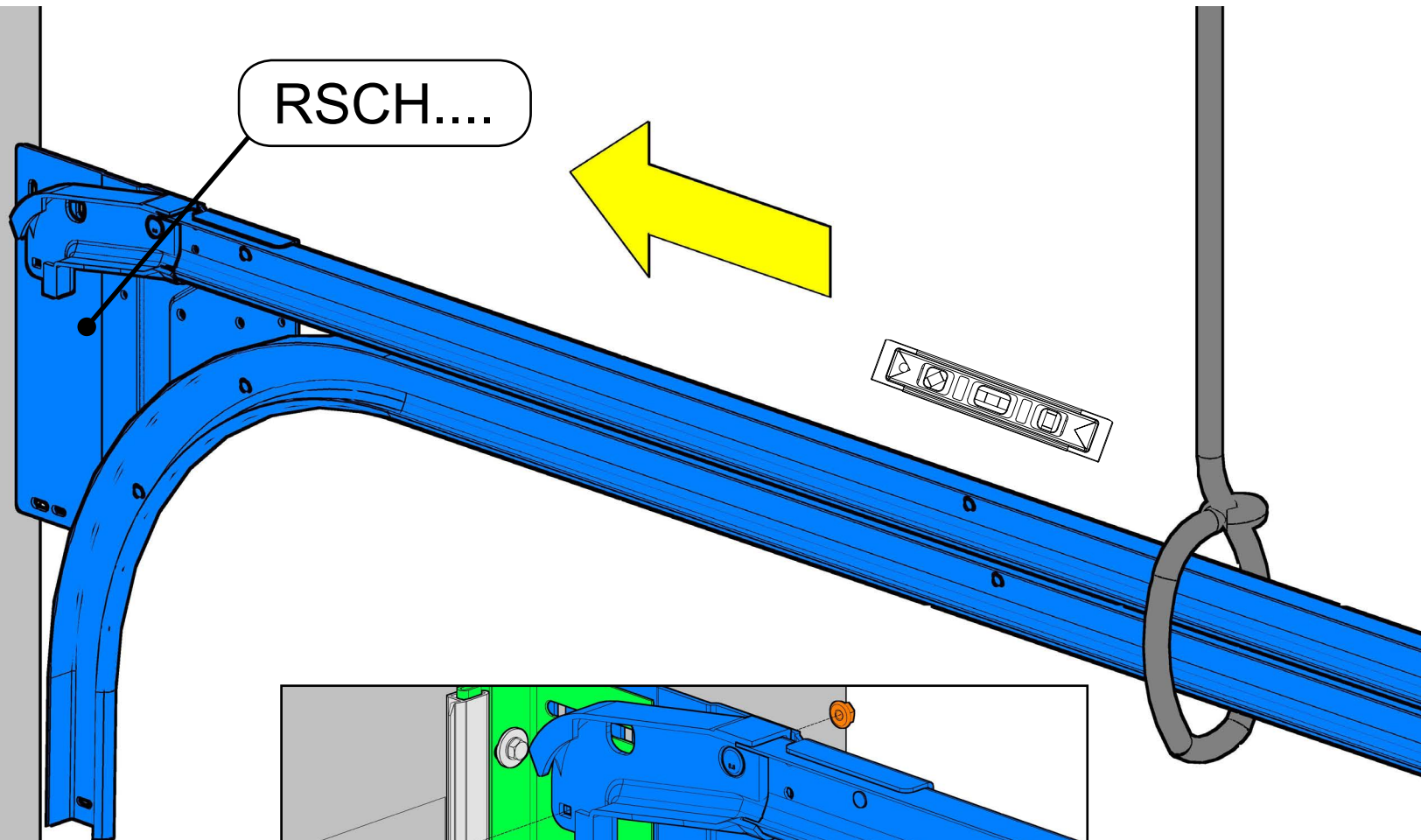
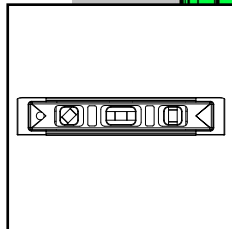
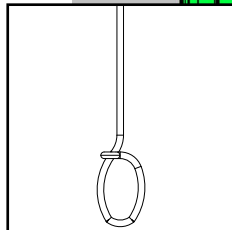
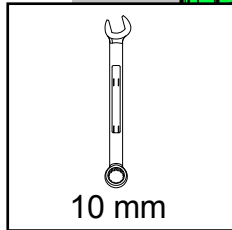
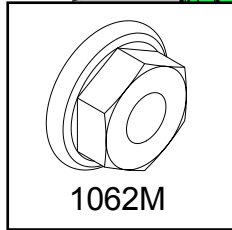
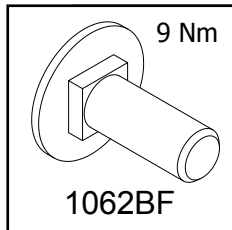

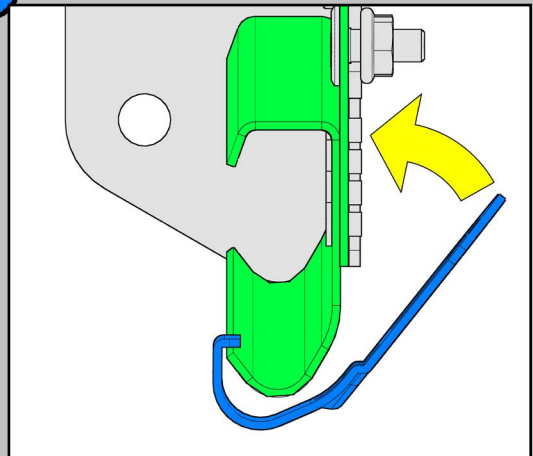
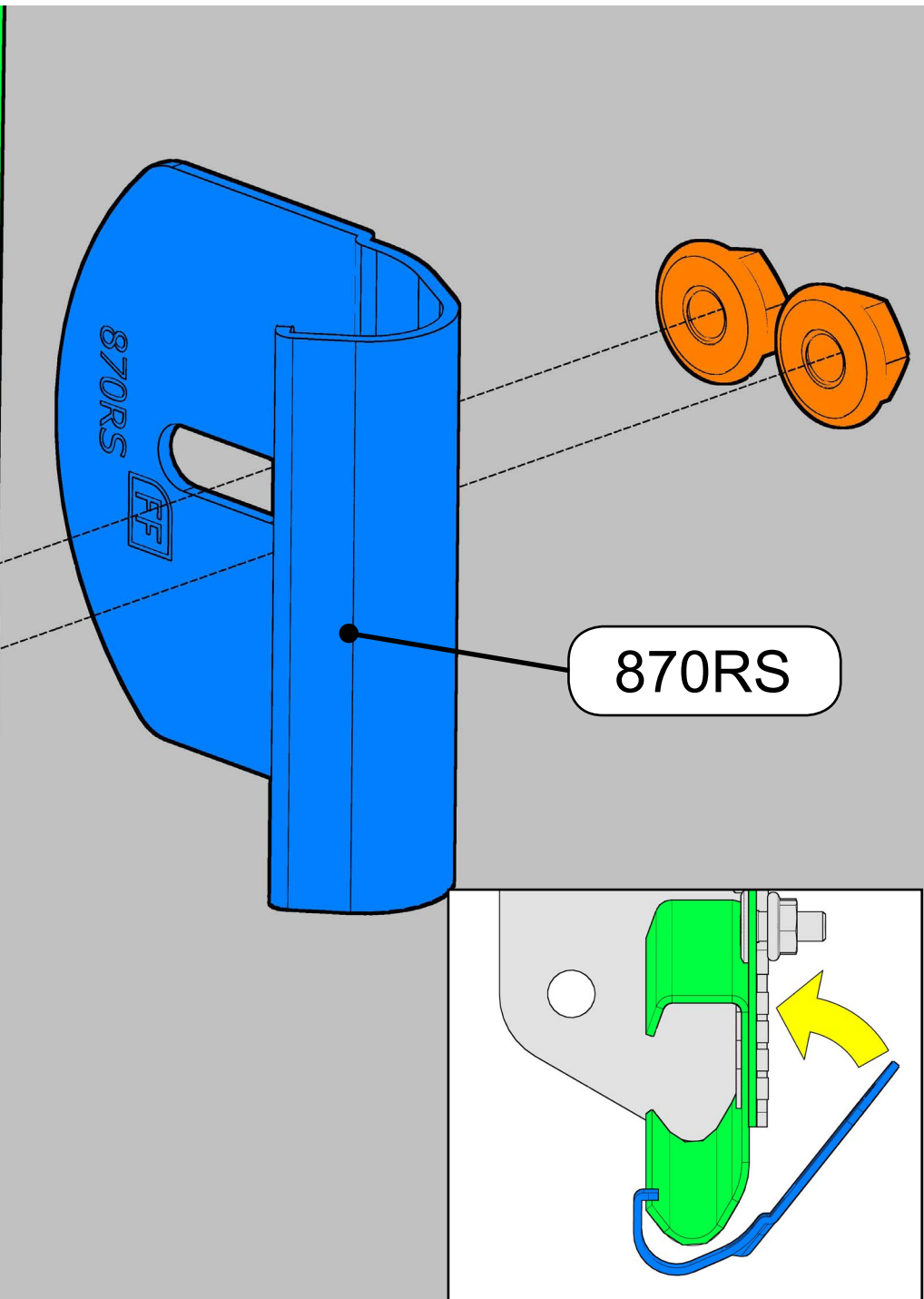
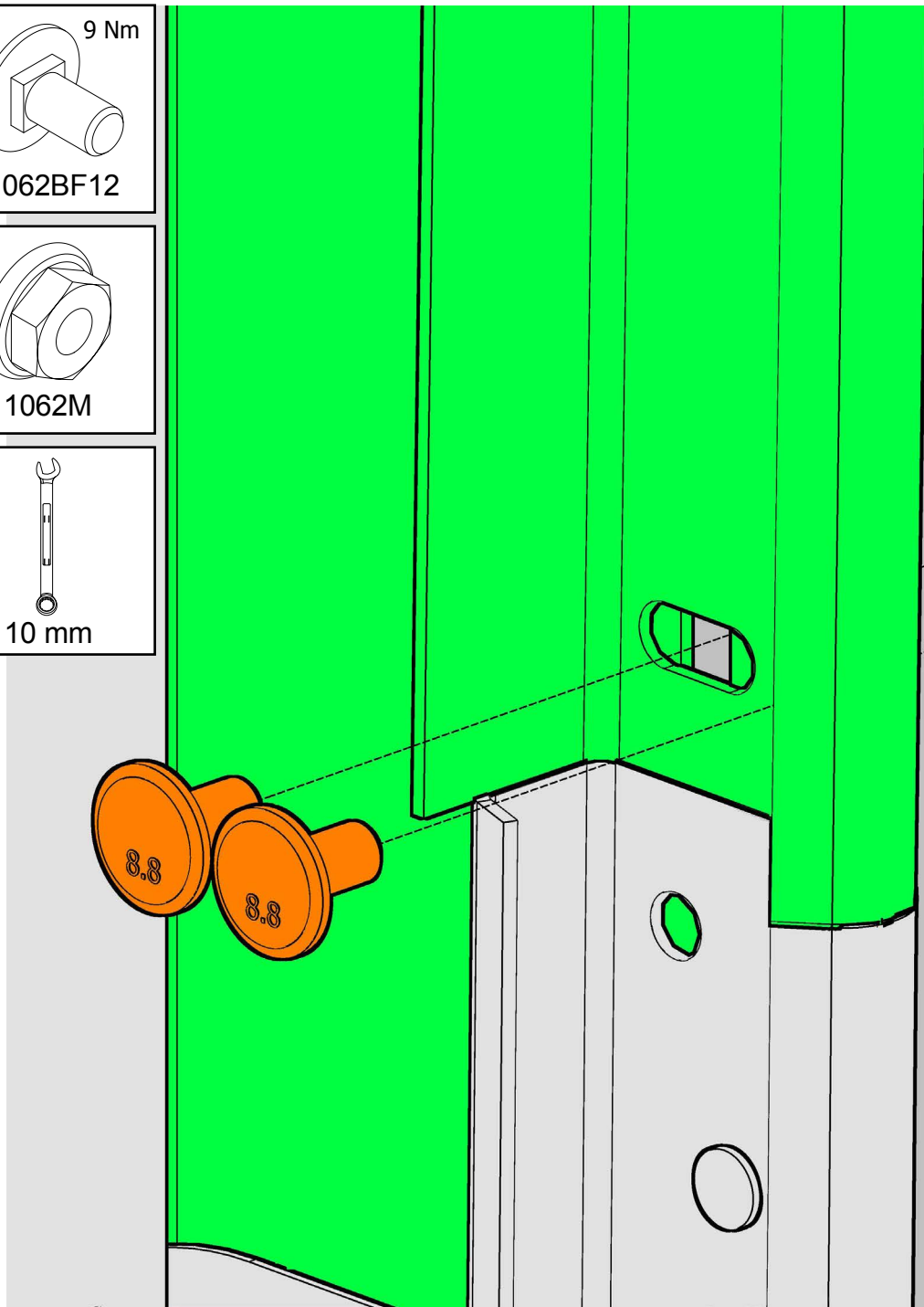
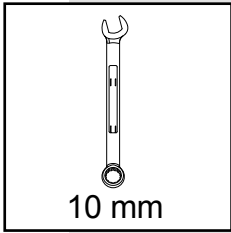
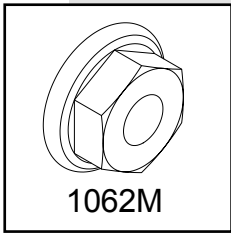
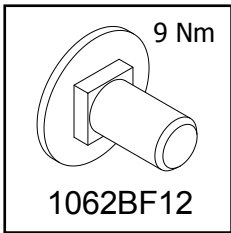

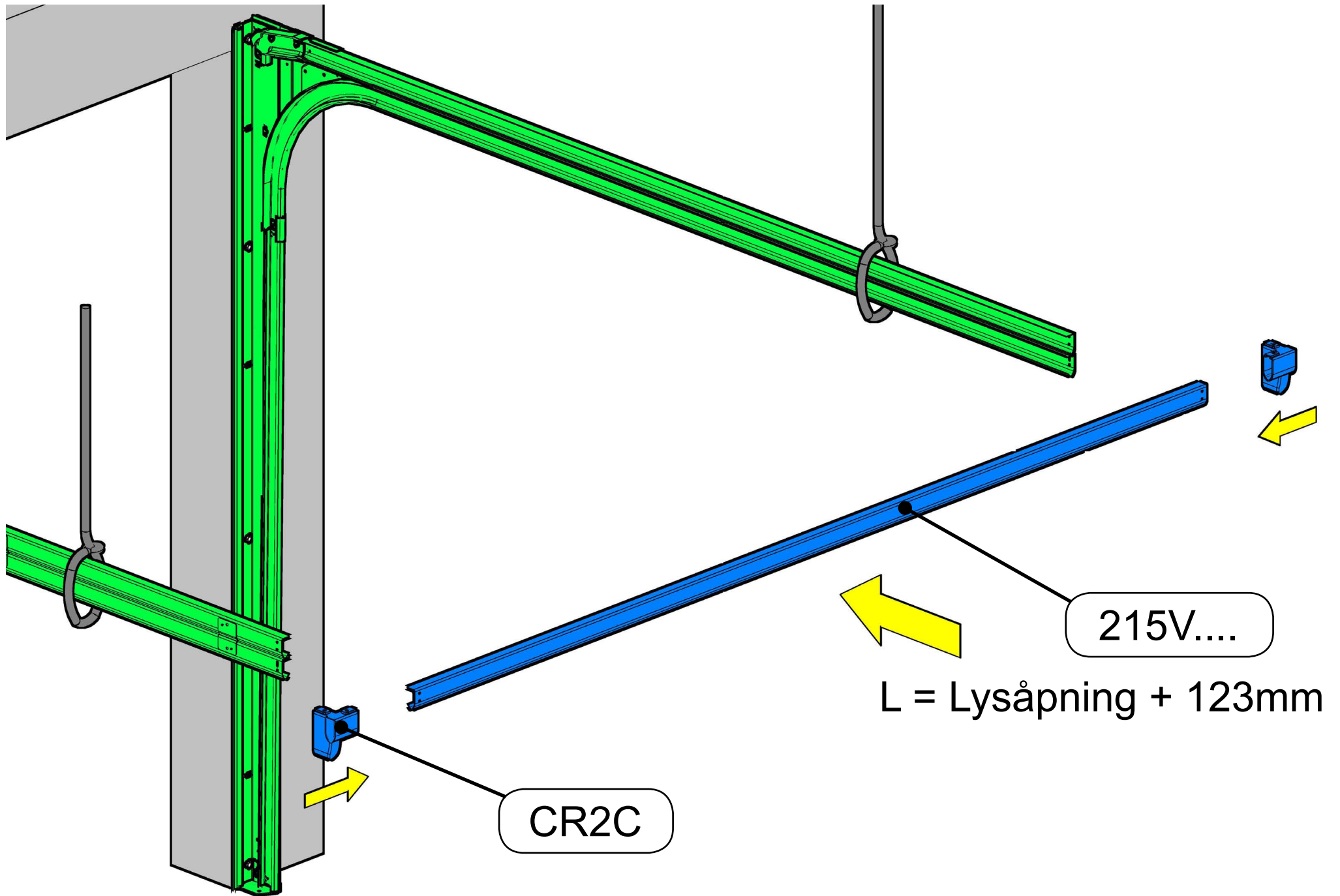

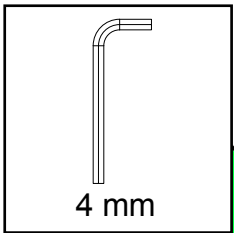

2-3 Nm

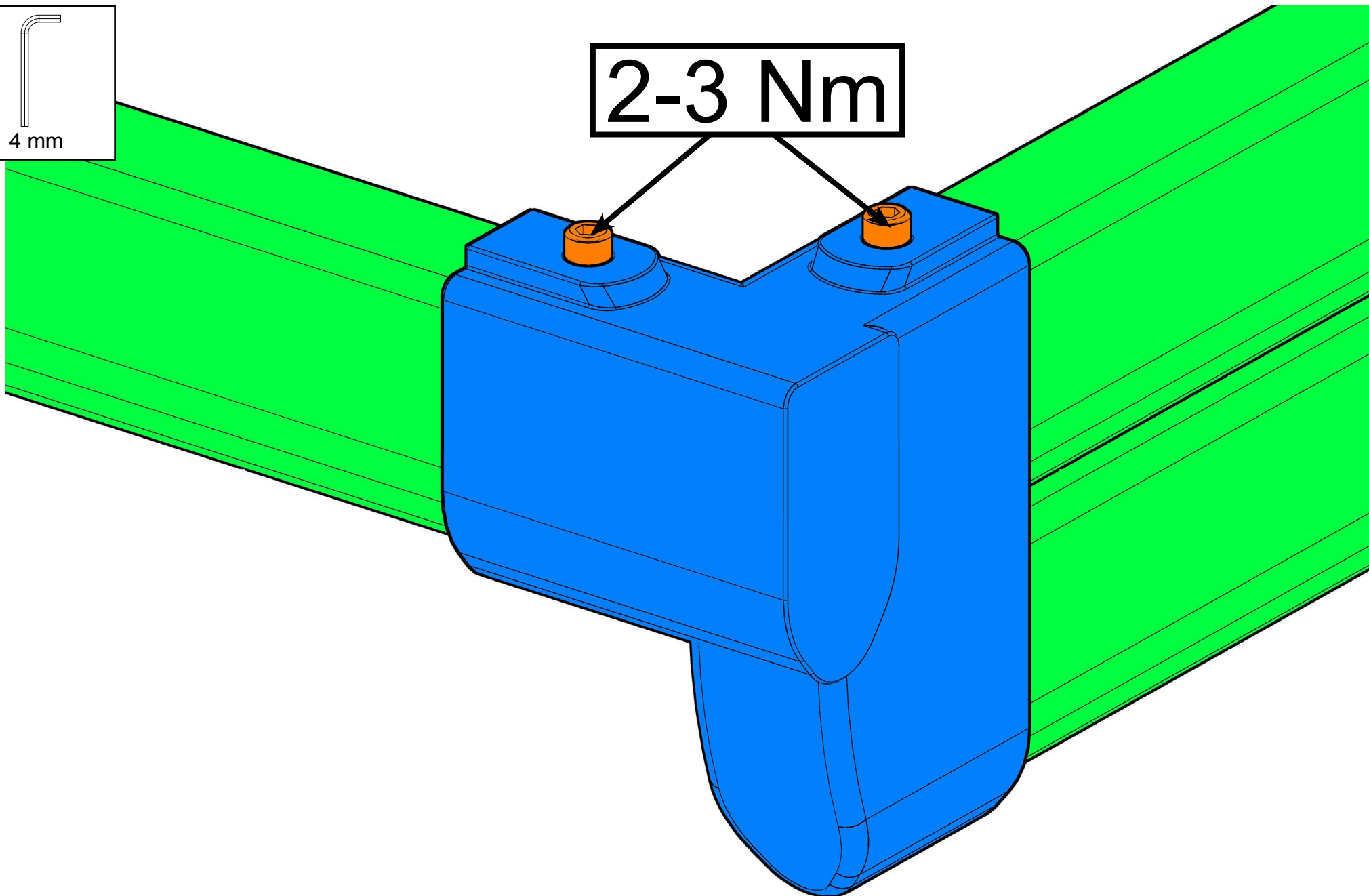

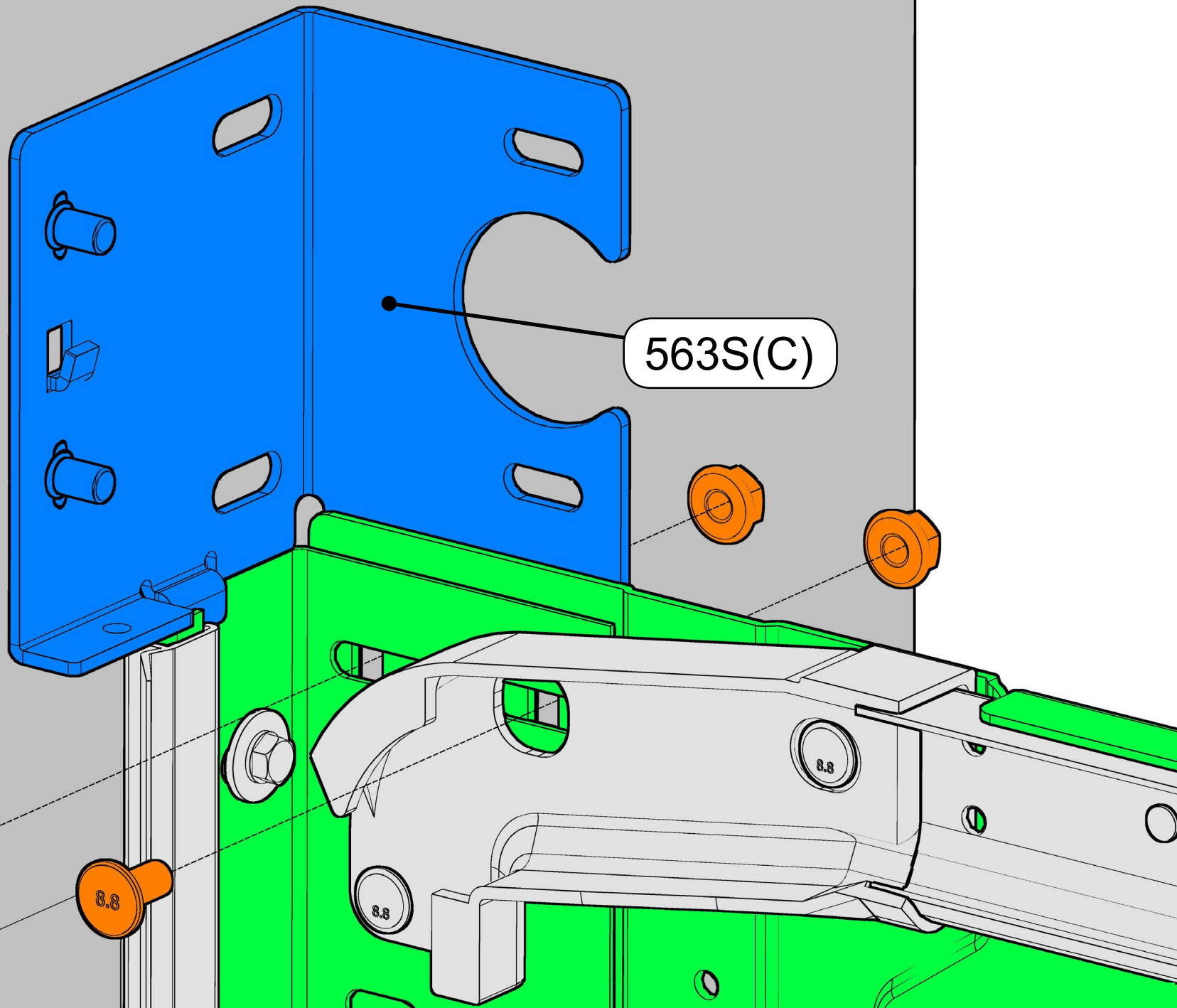
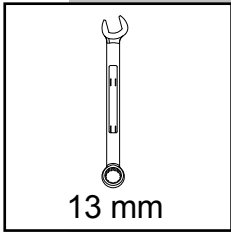
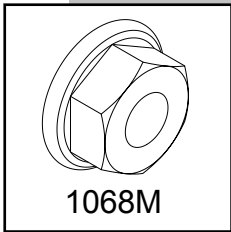
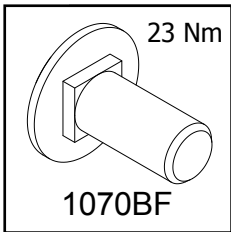

563S(C)

8.8

8.8

8.8

8.8

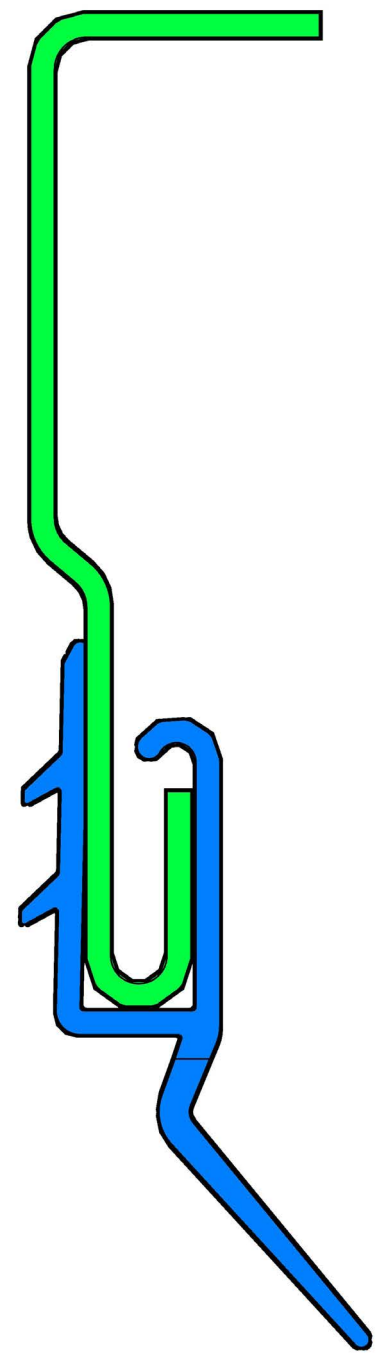
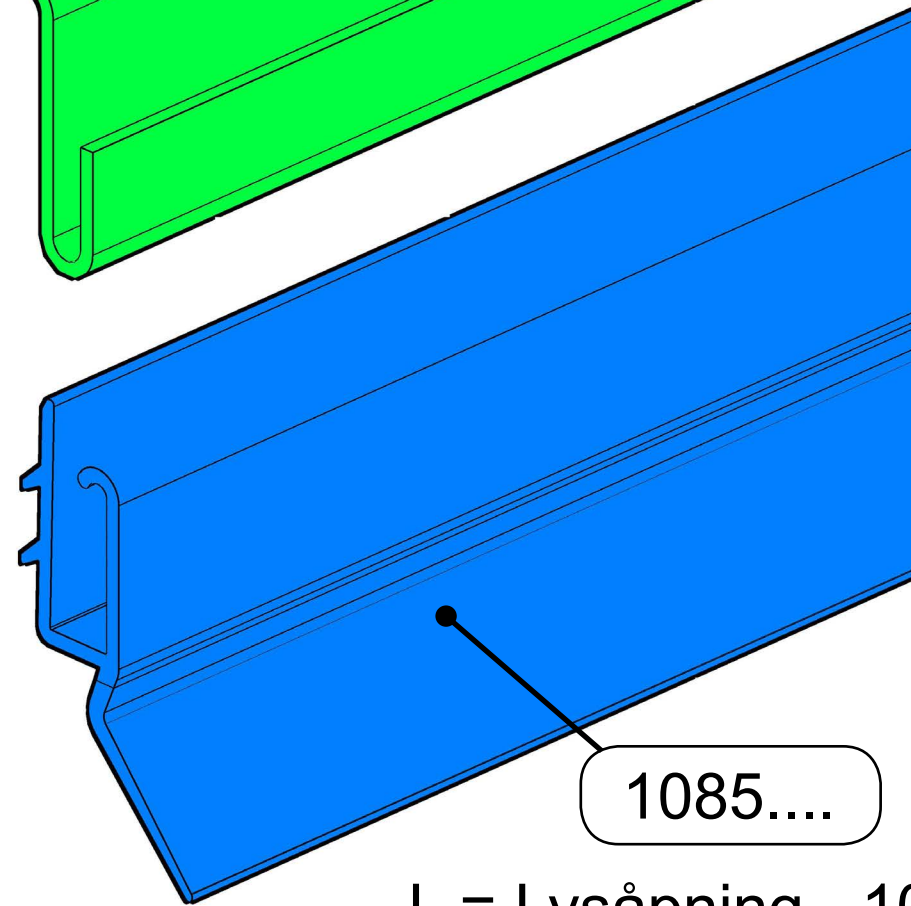
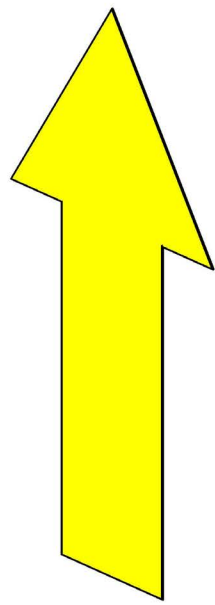
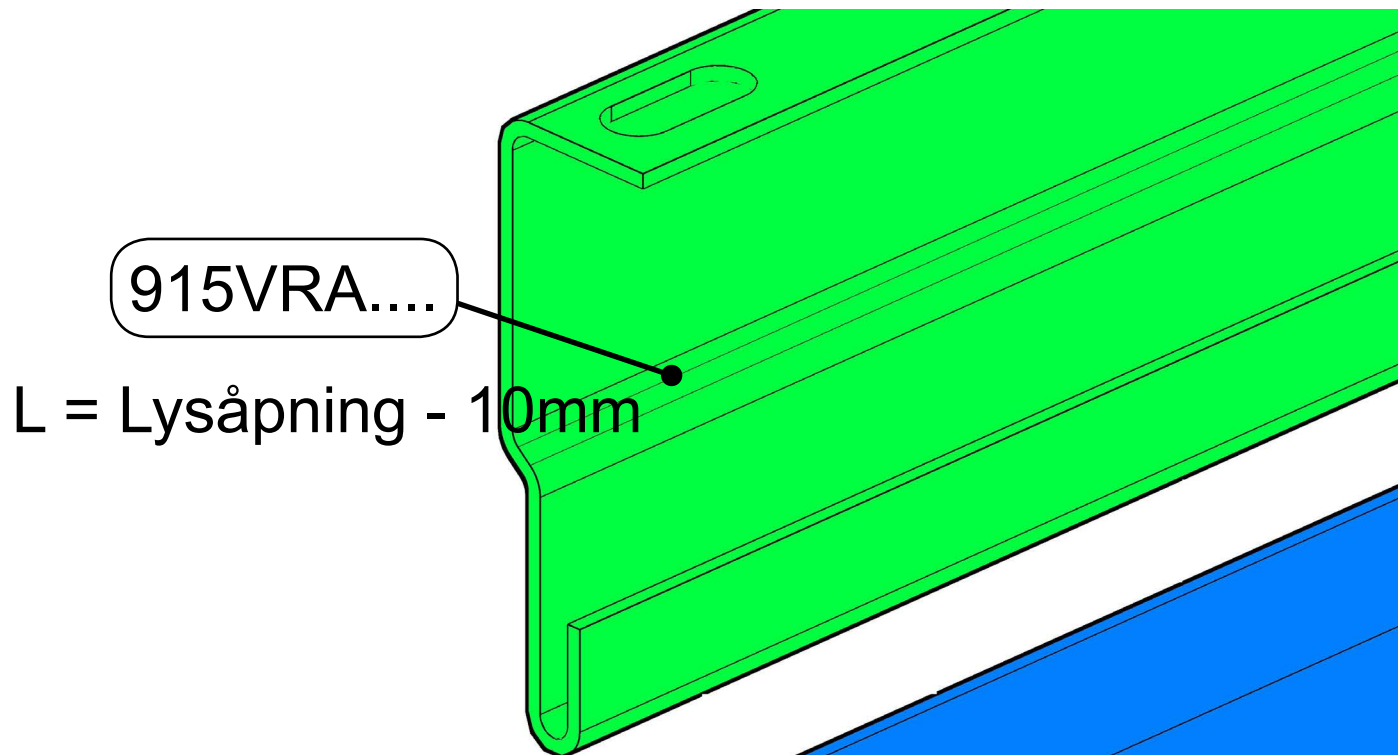

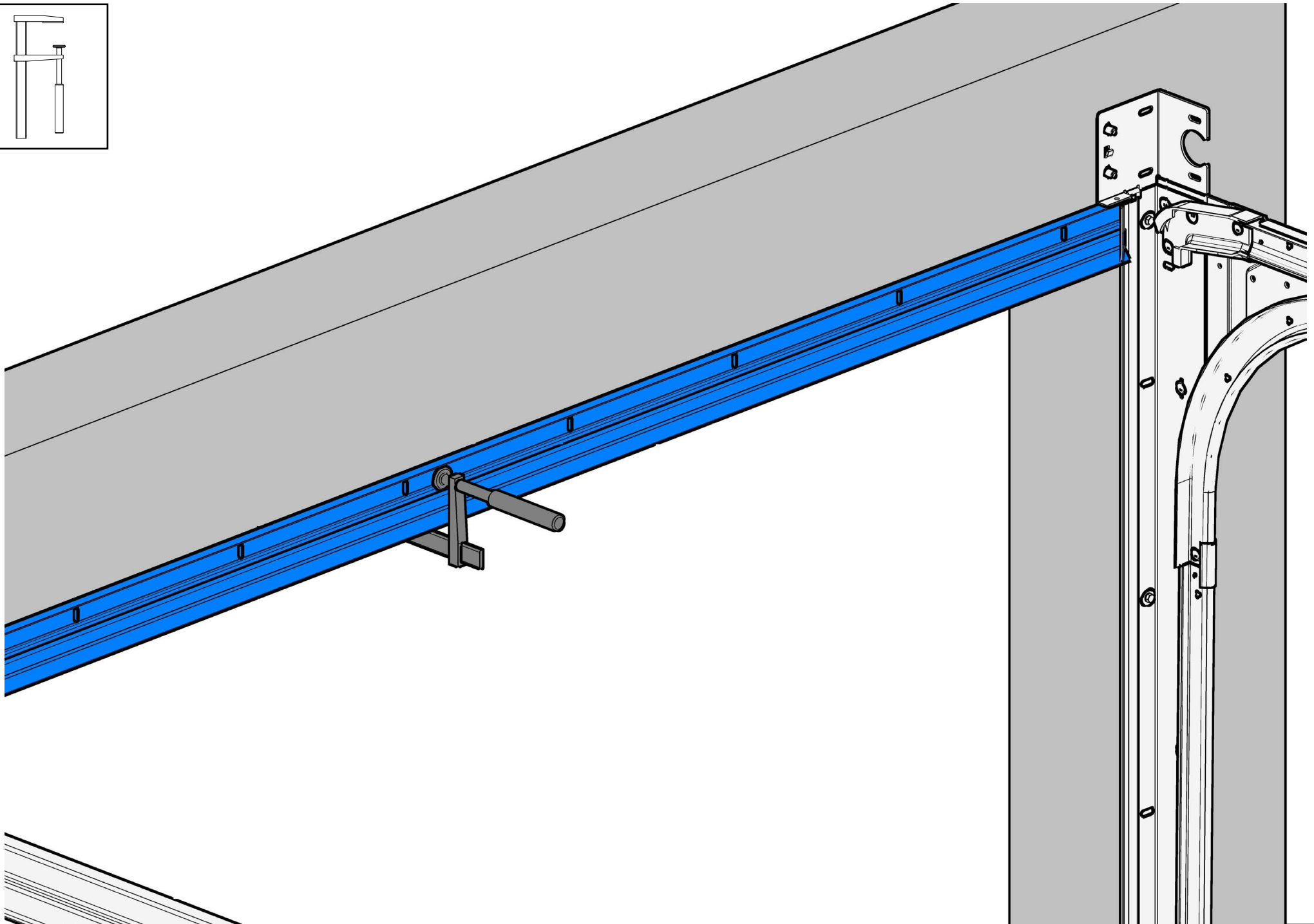
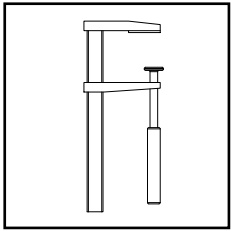

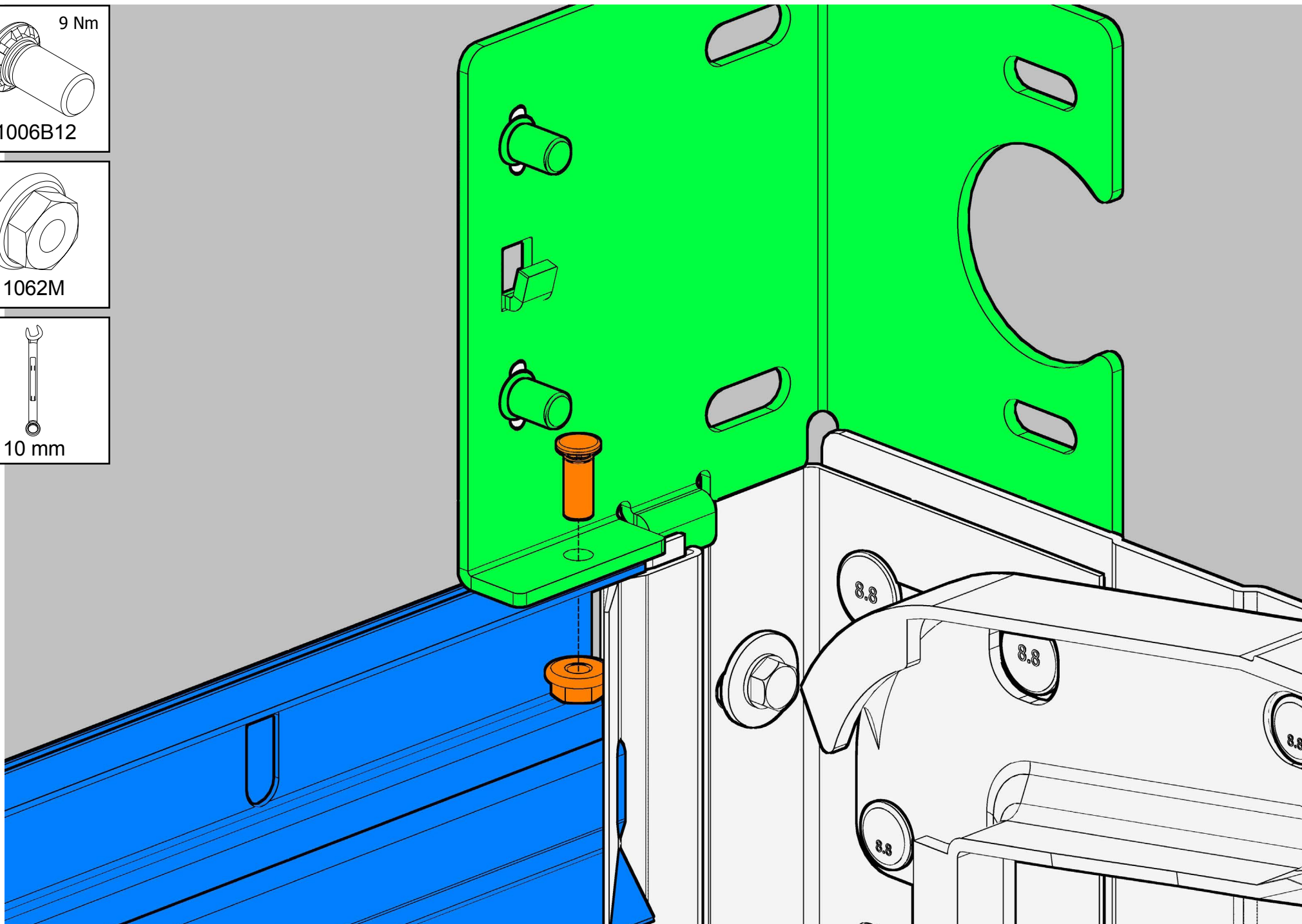
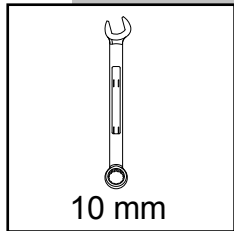
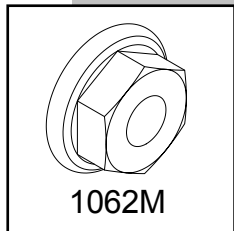
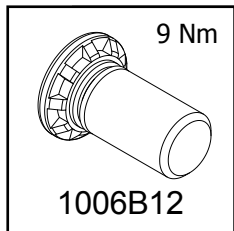



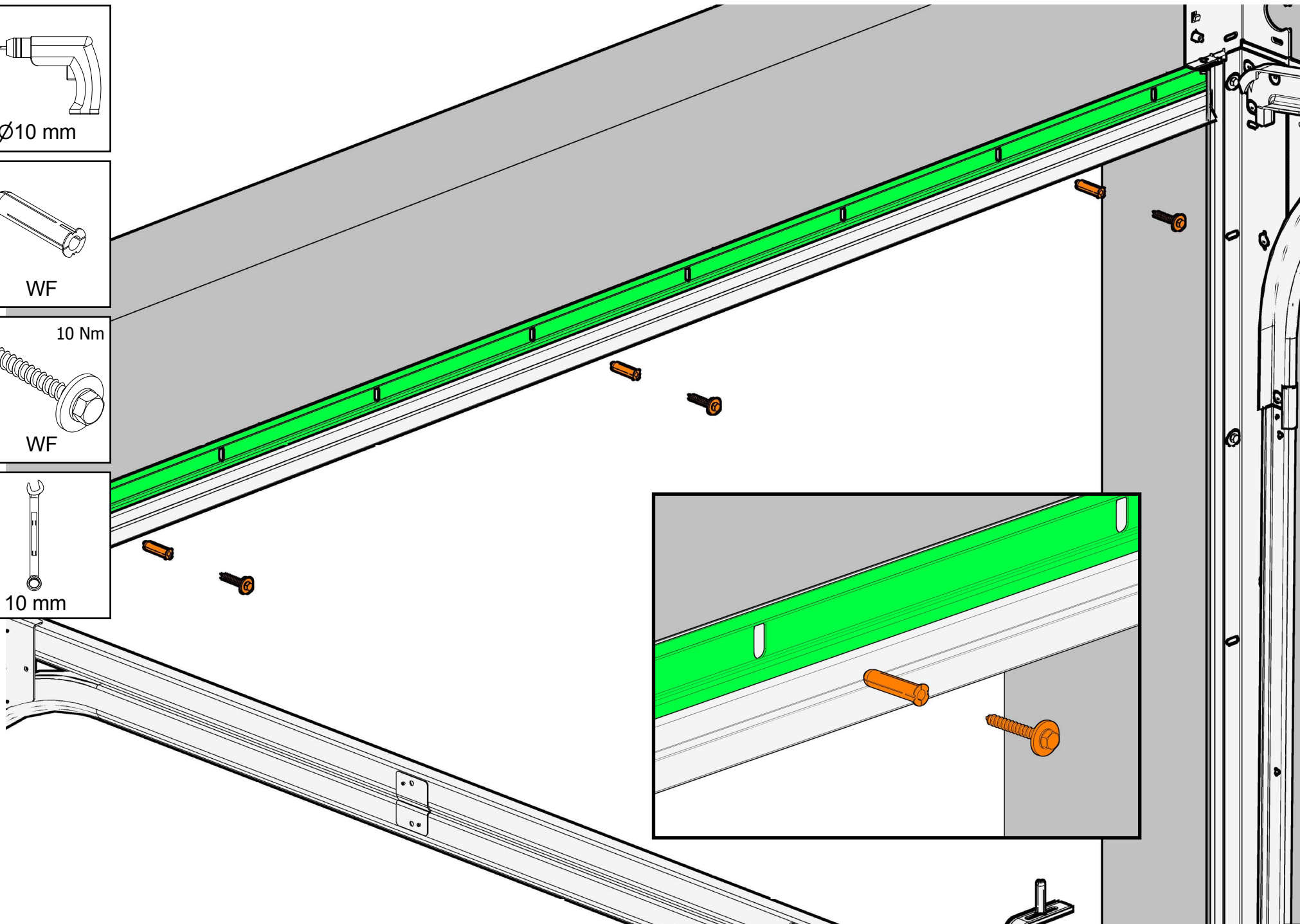
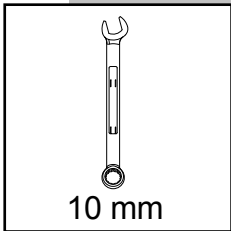
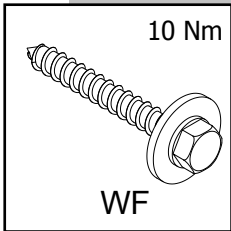
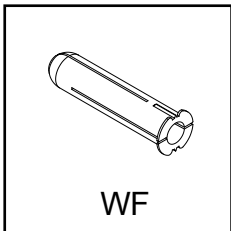
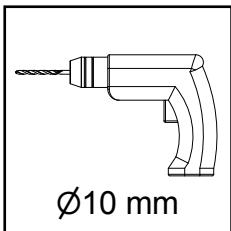

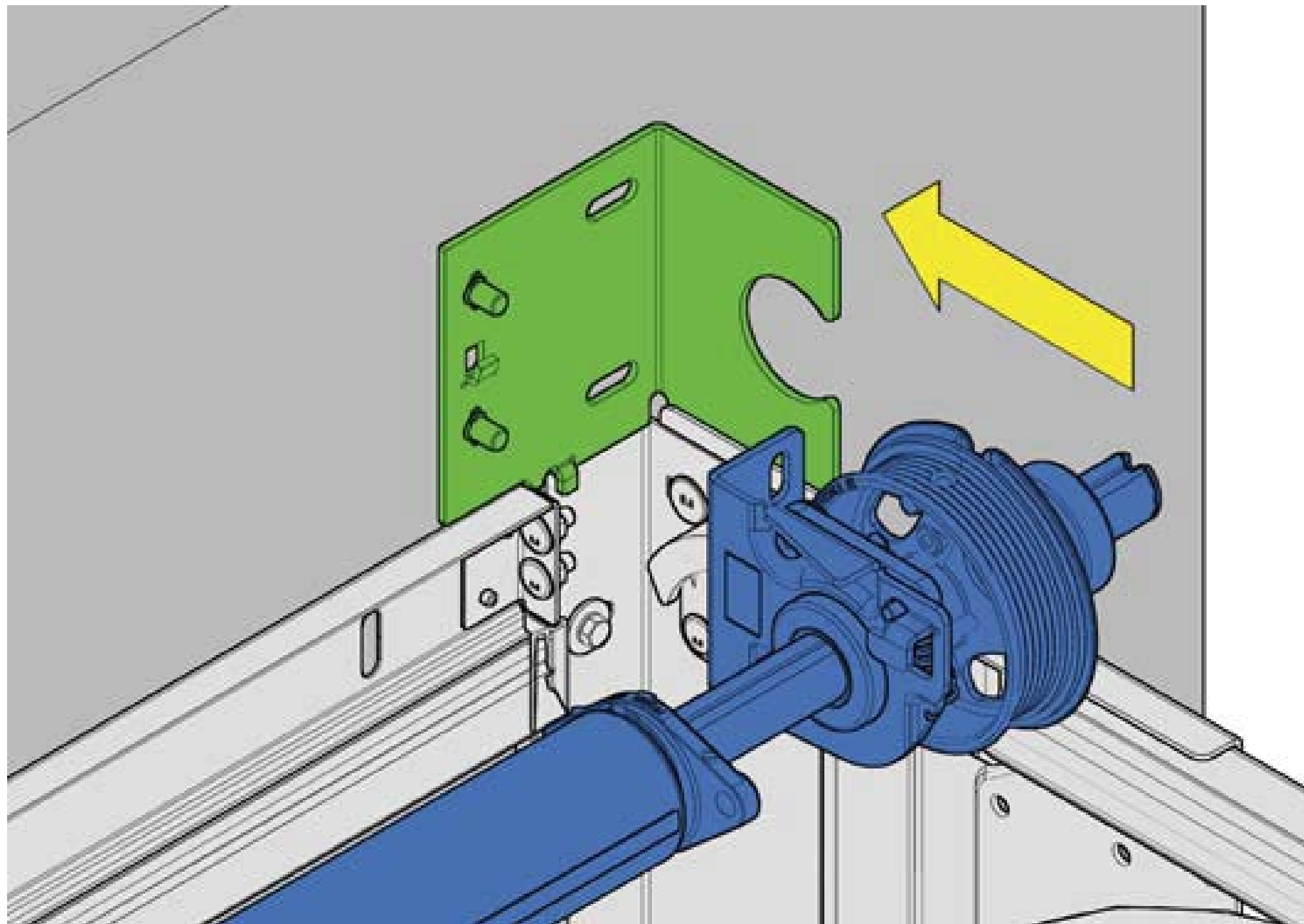

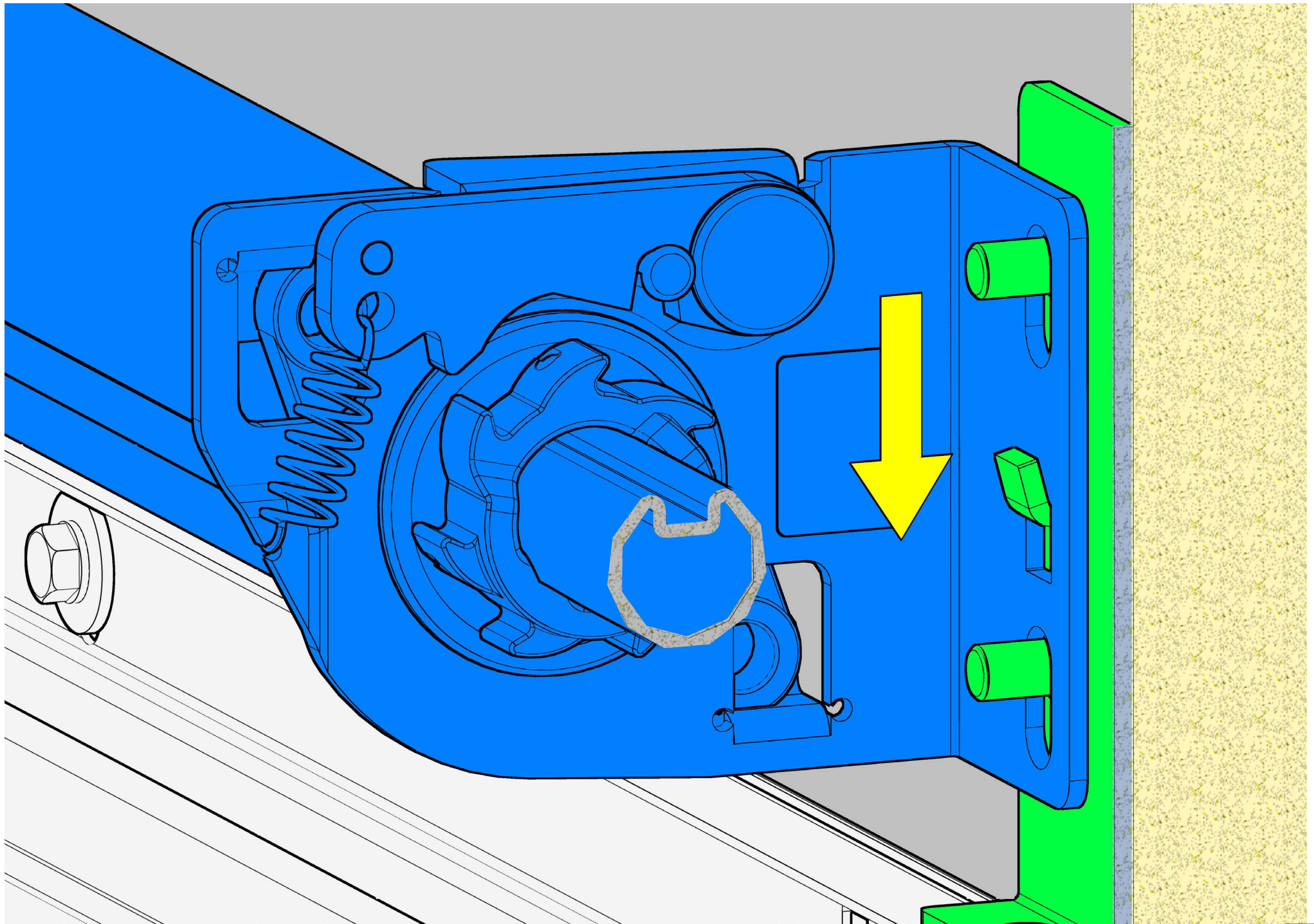

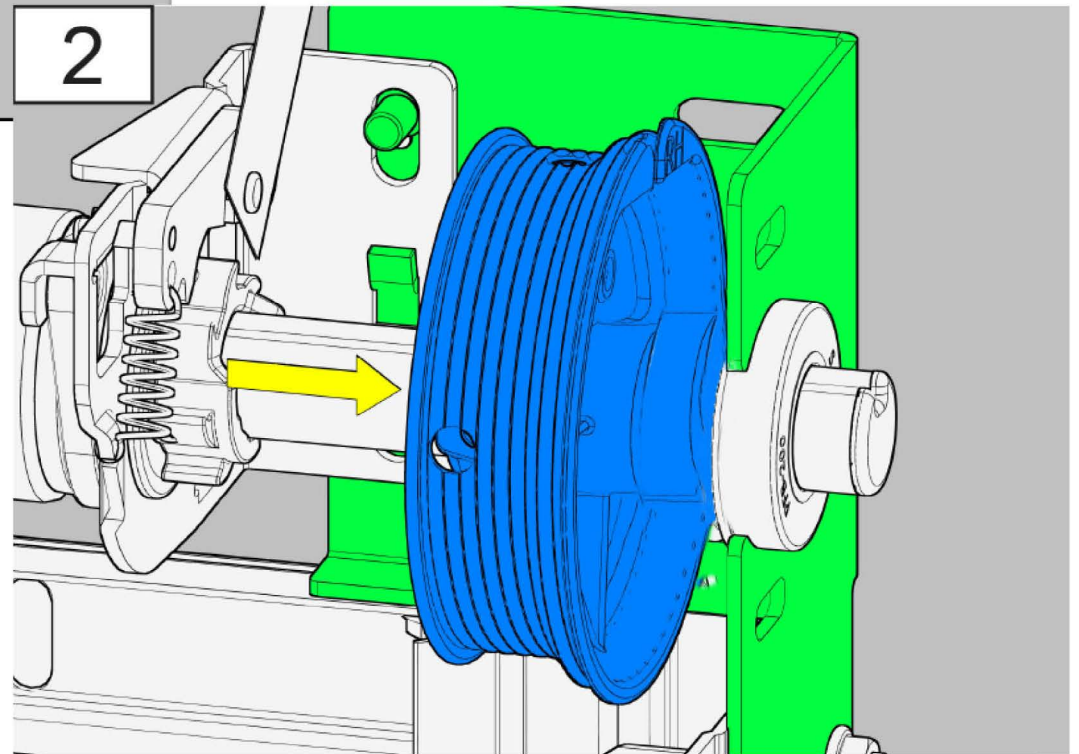
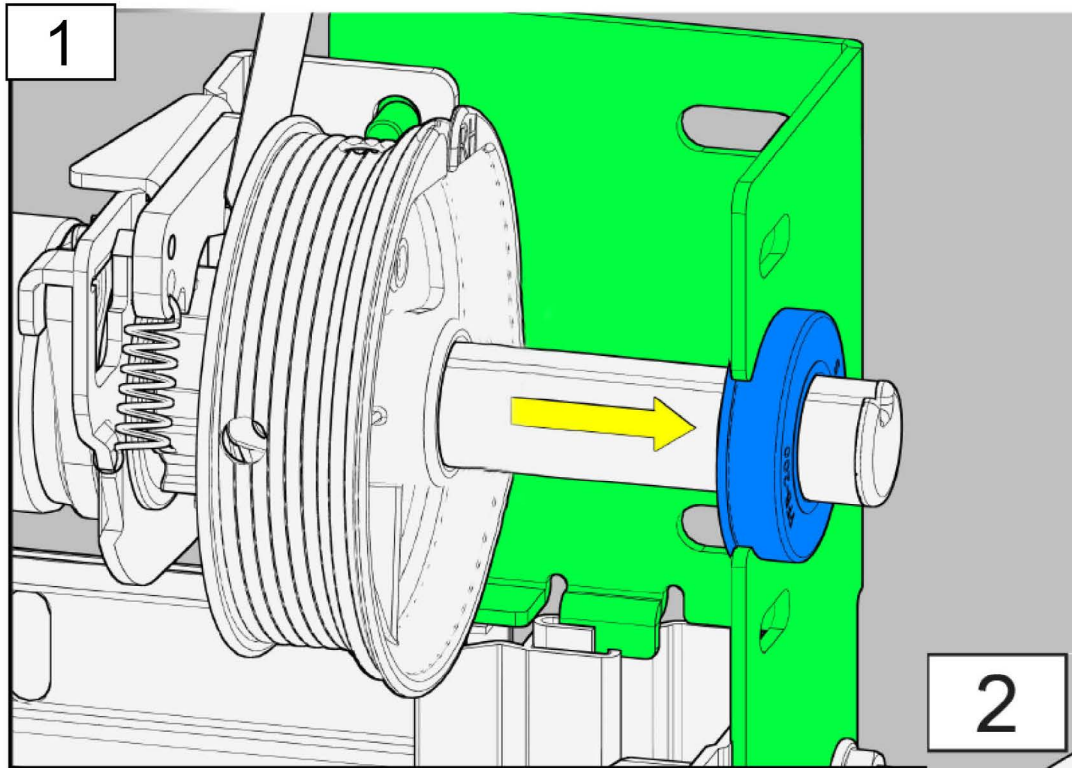

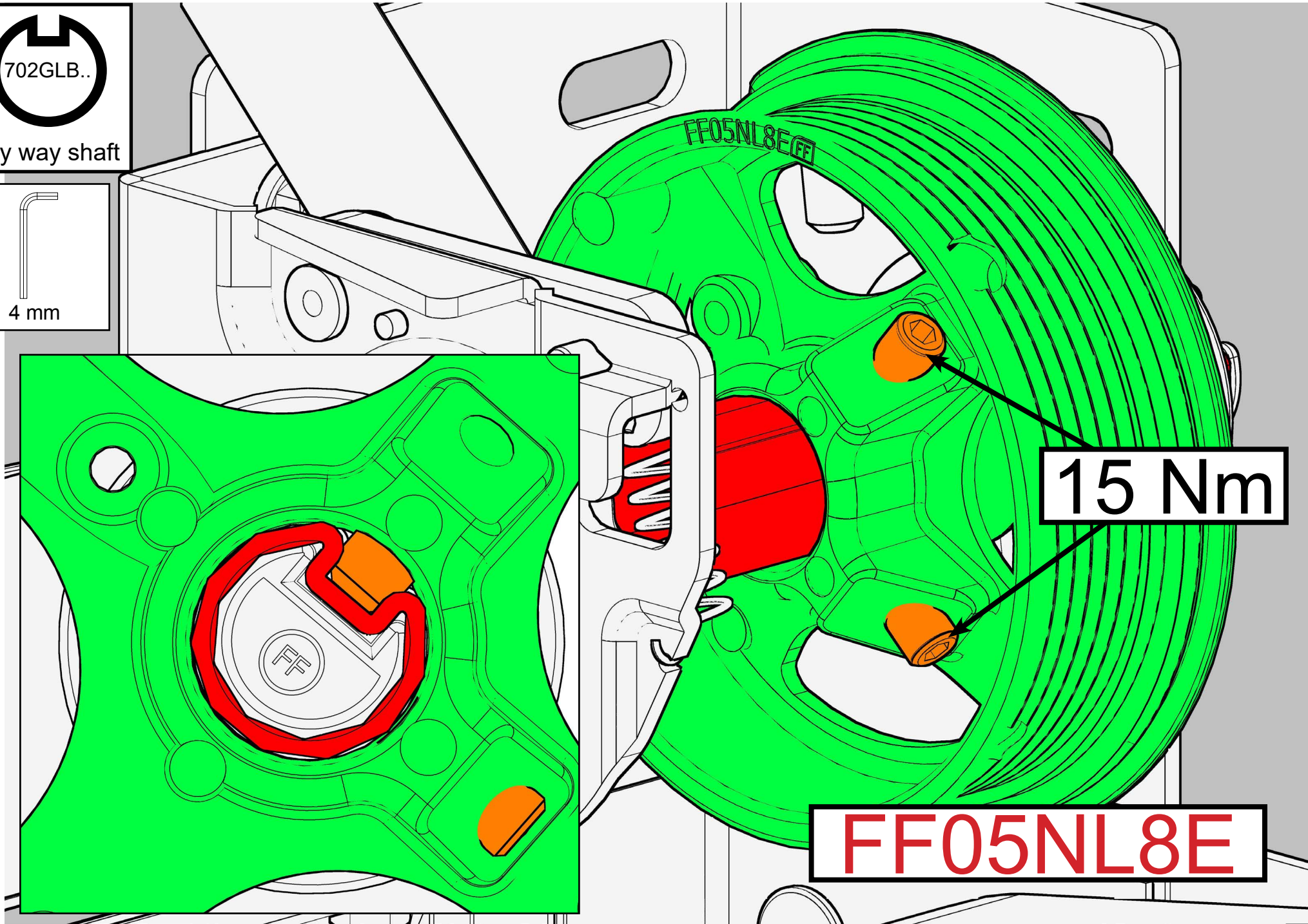
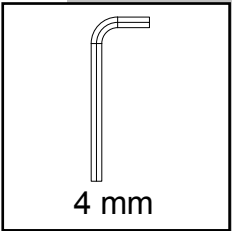
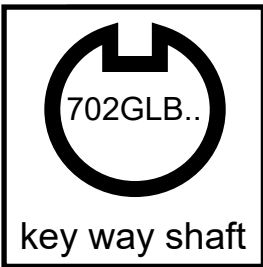

15 Nm

FF05NL8E

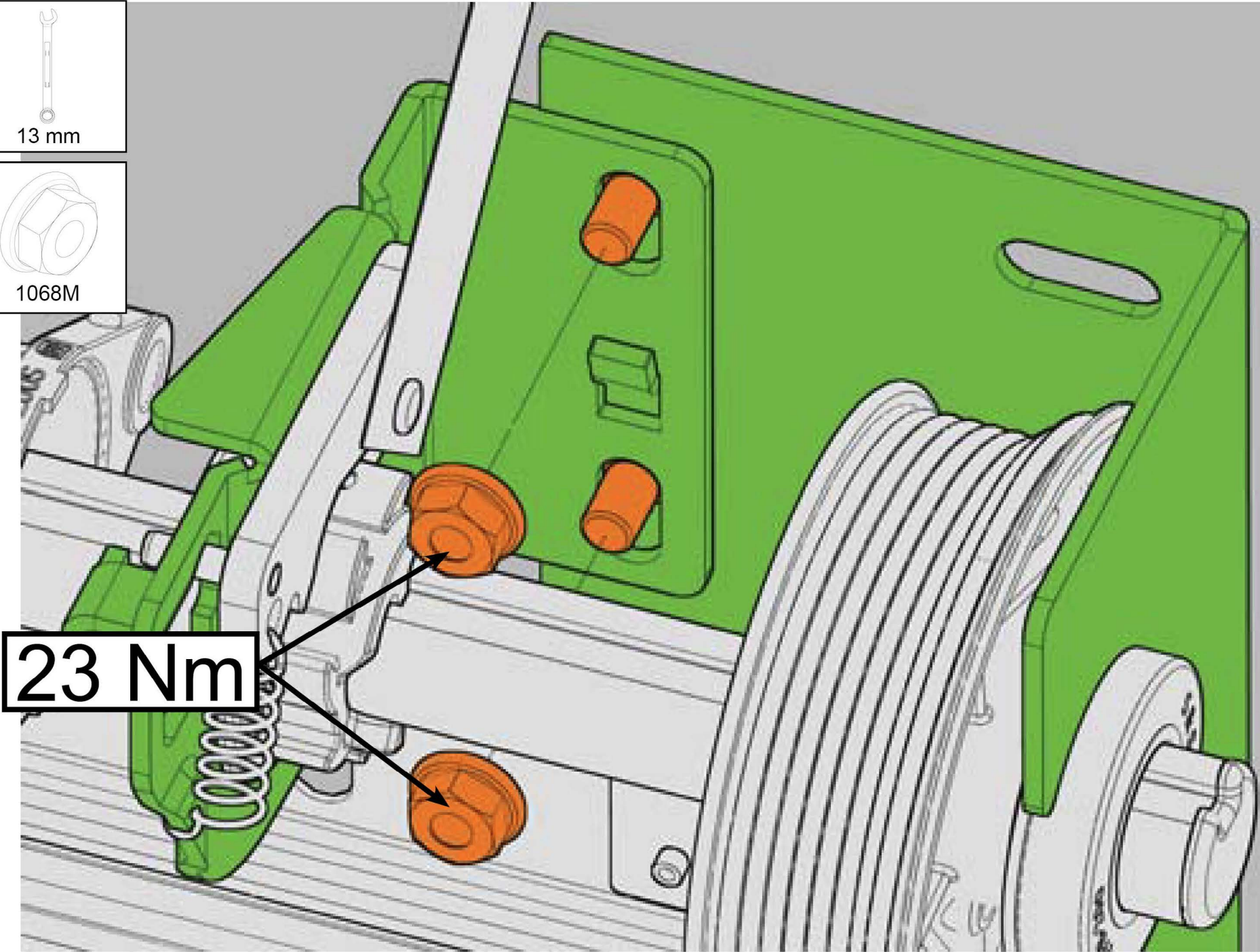
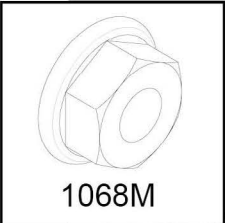

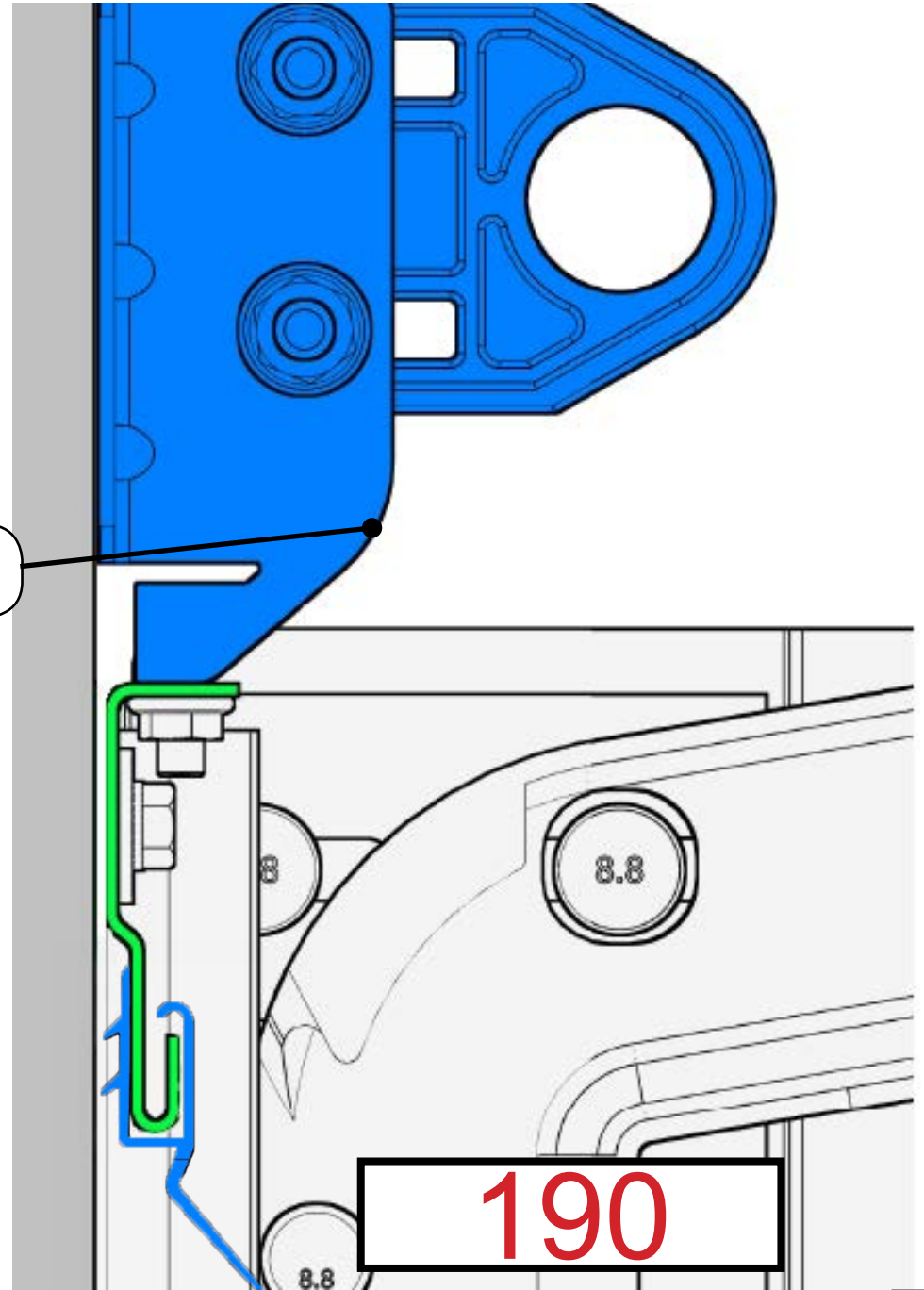
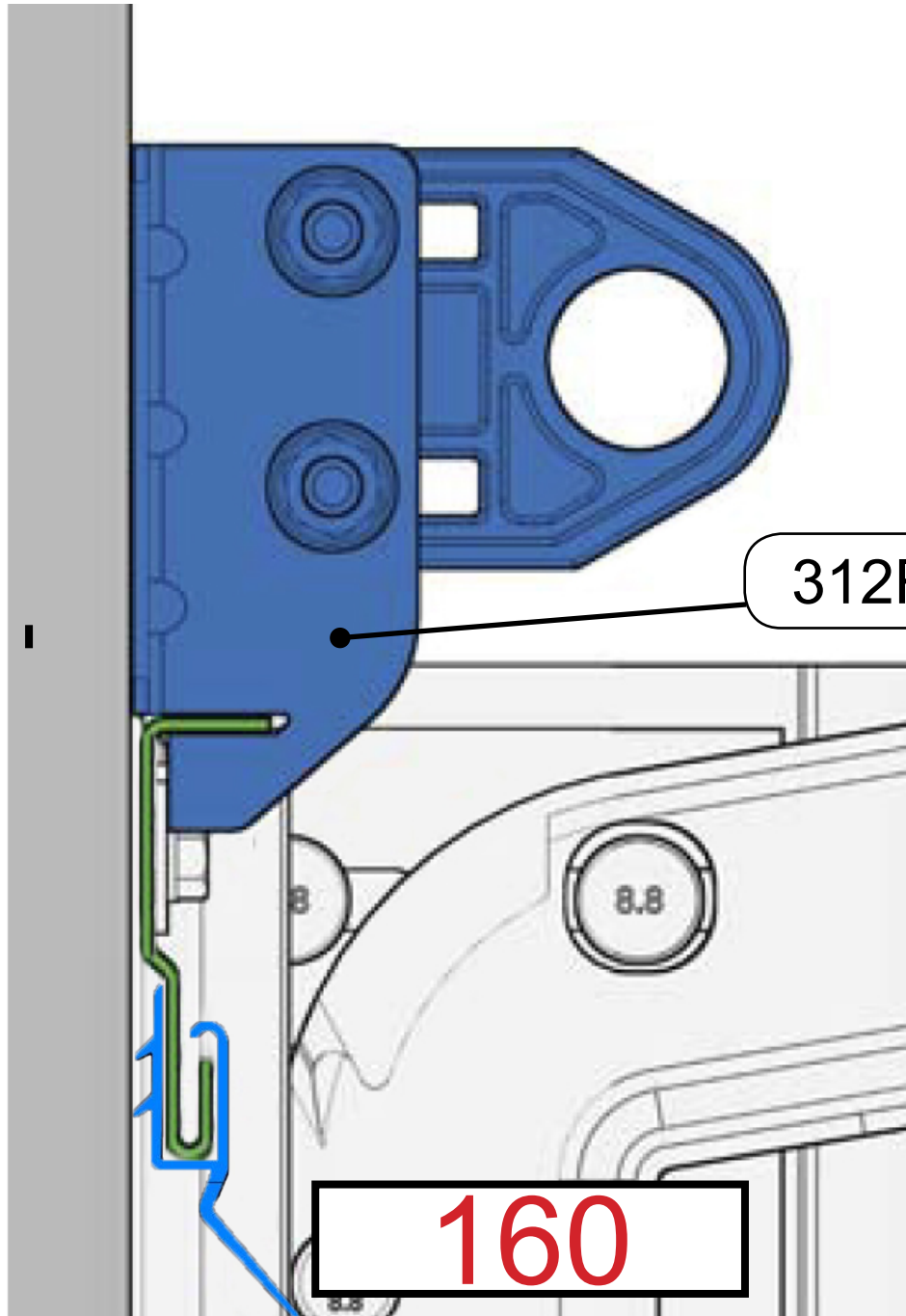

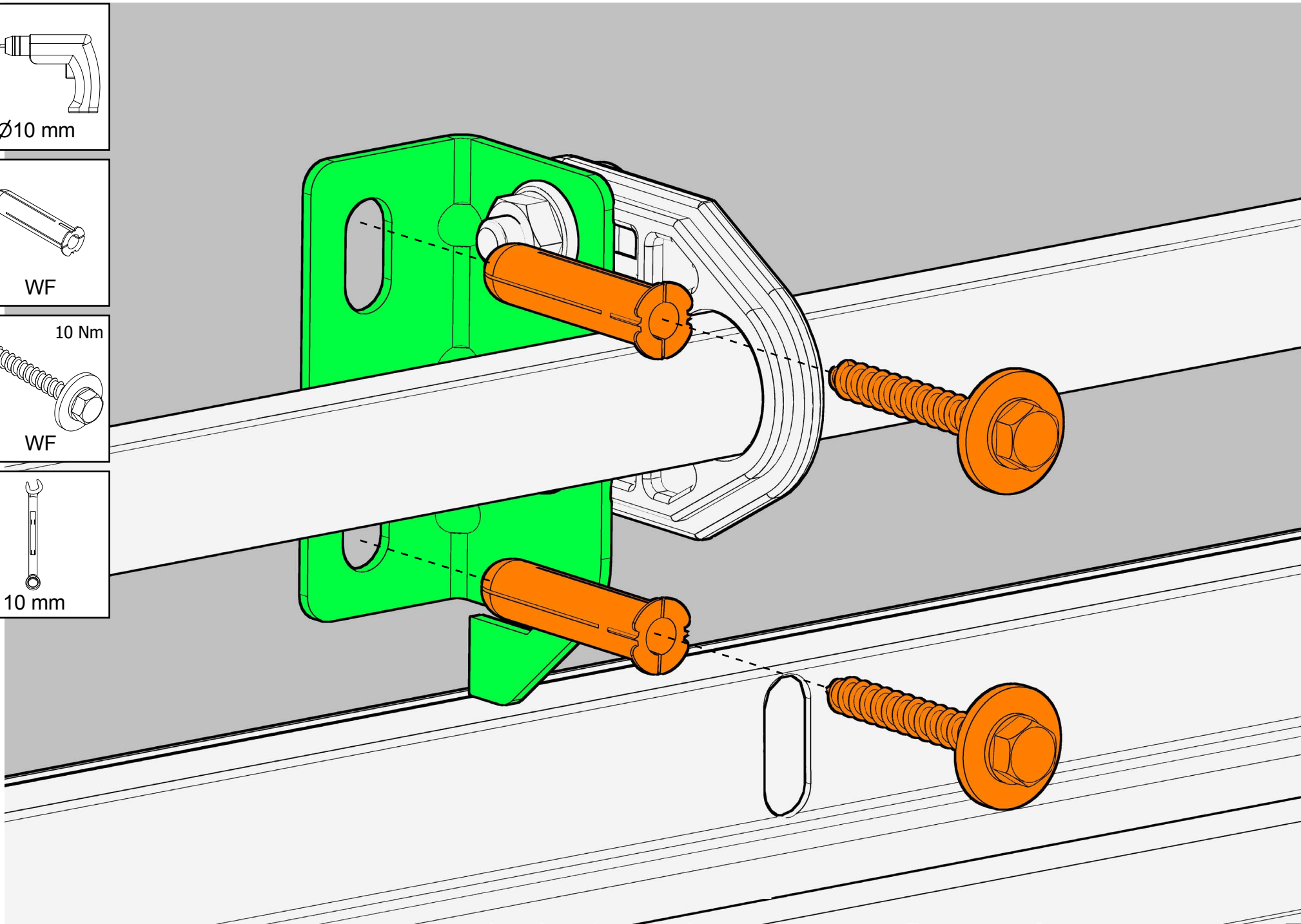
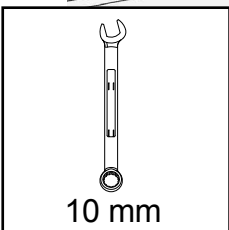
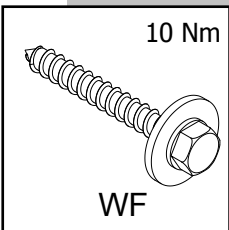
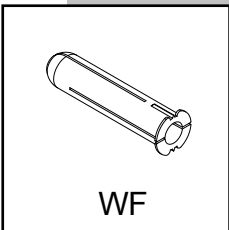
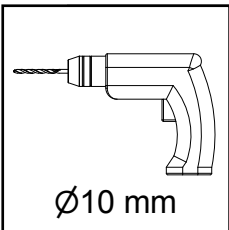



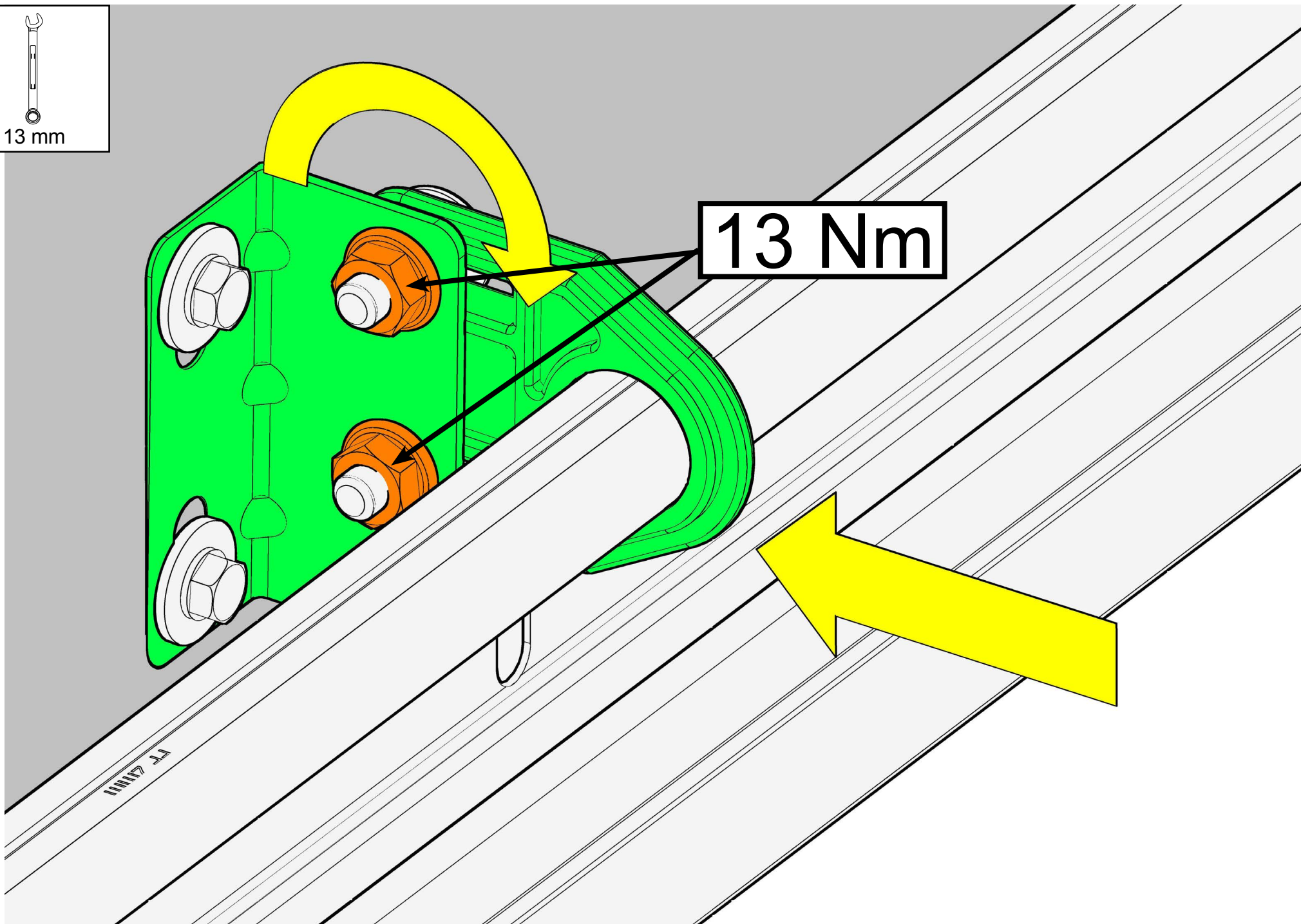
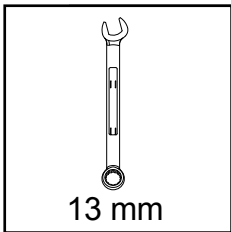

FT 41111

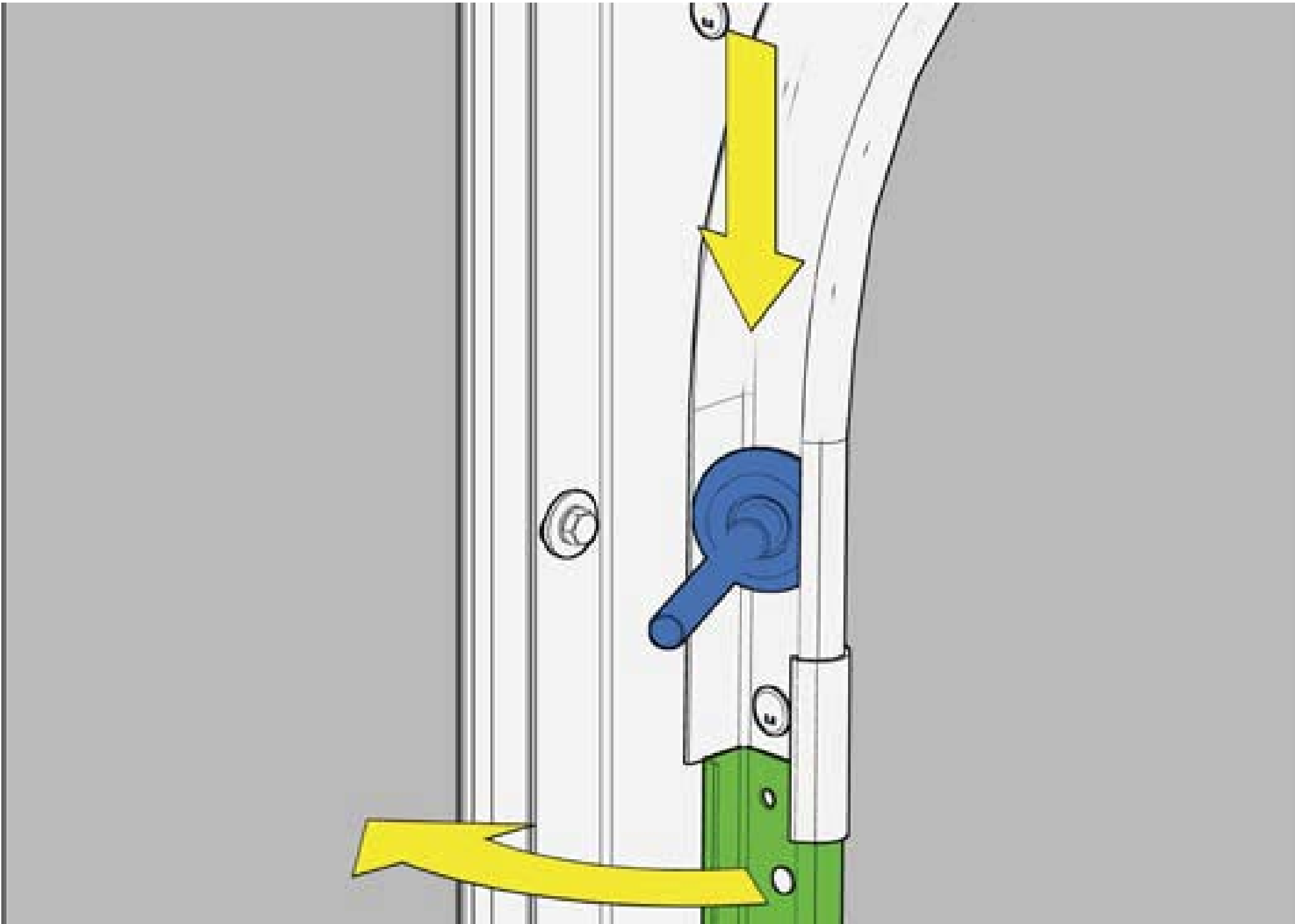

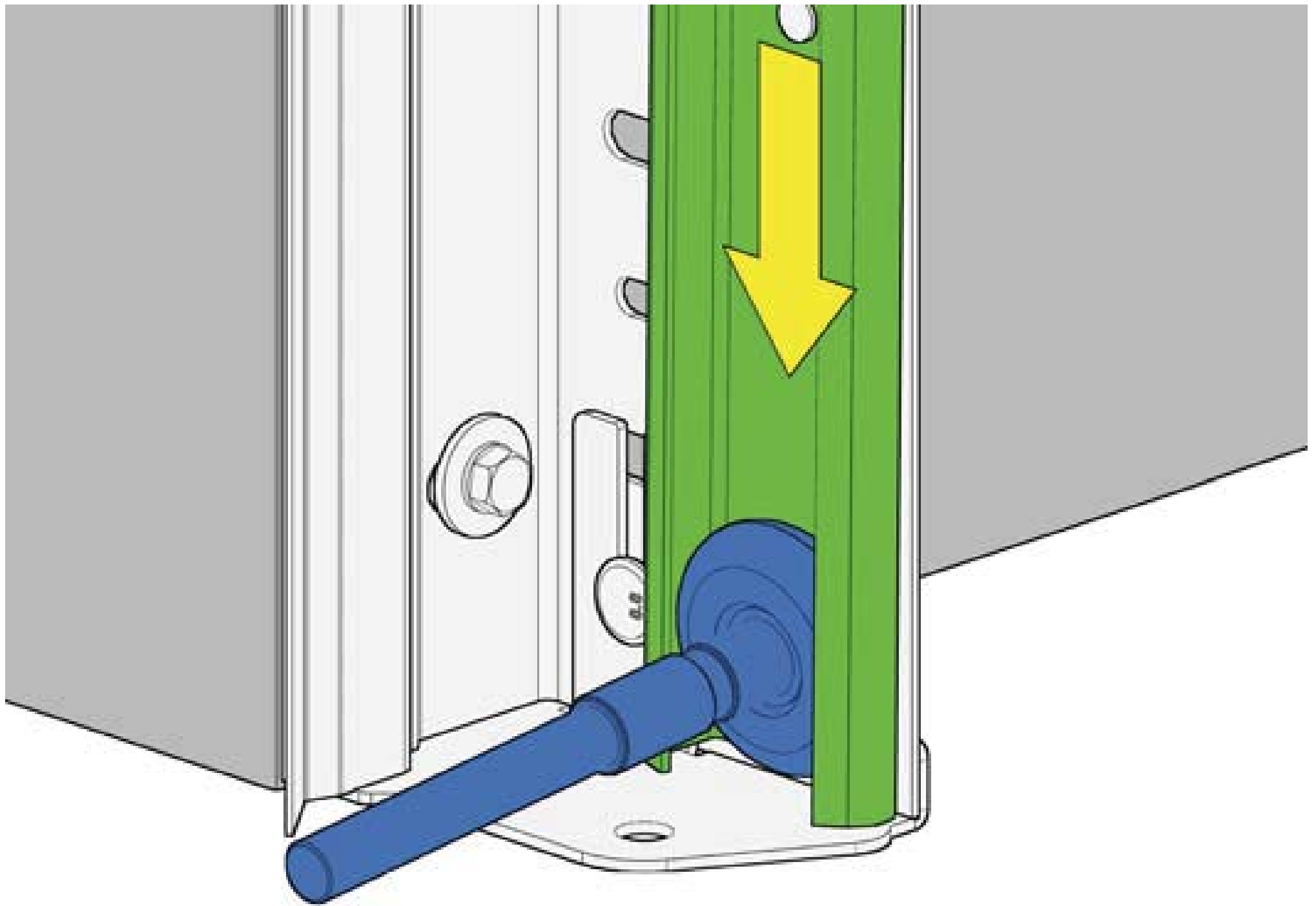

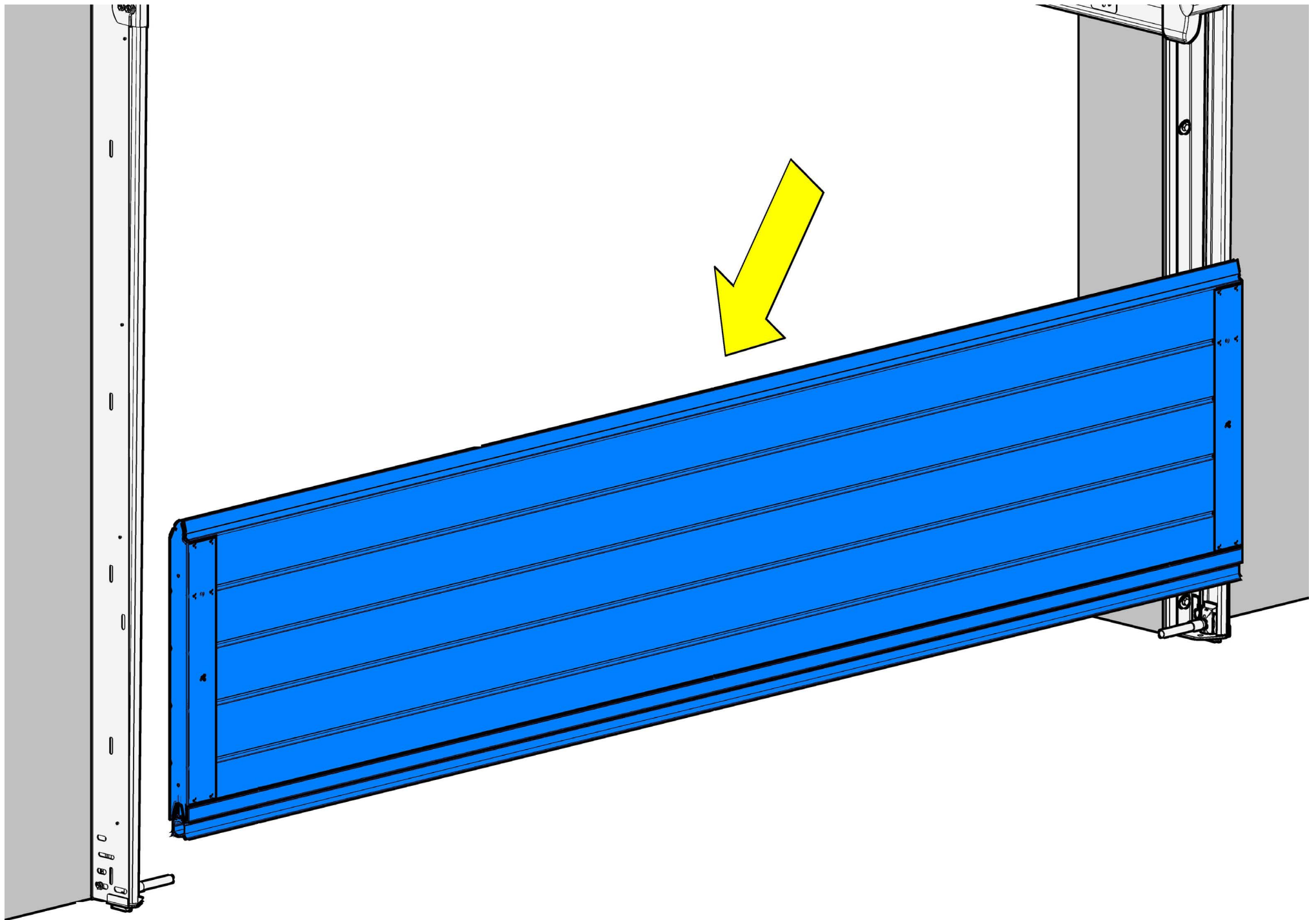

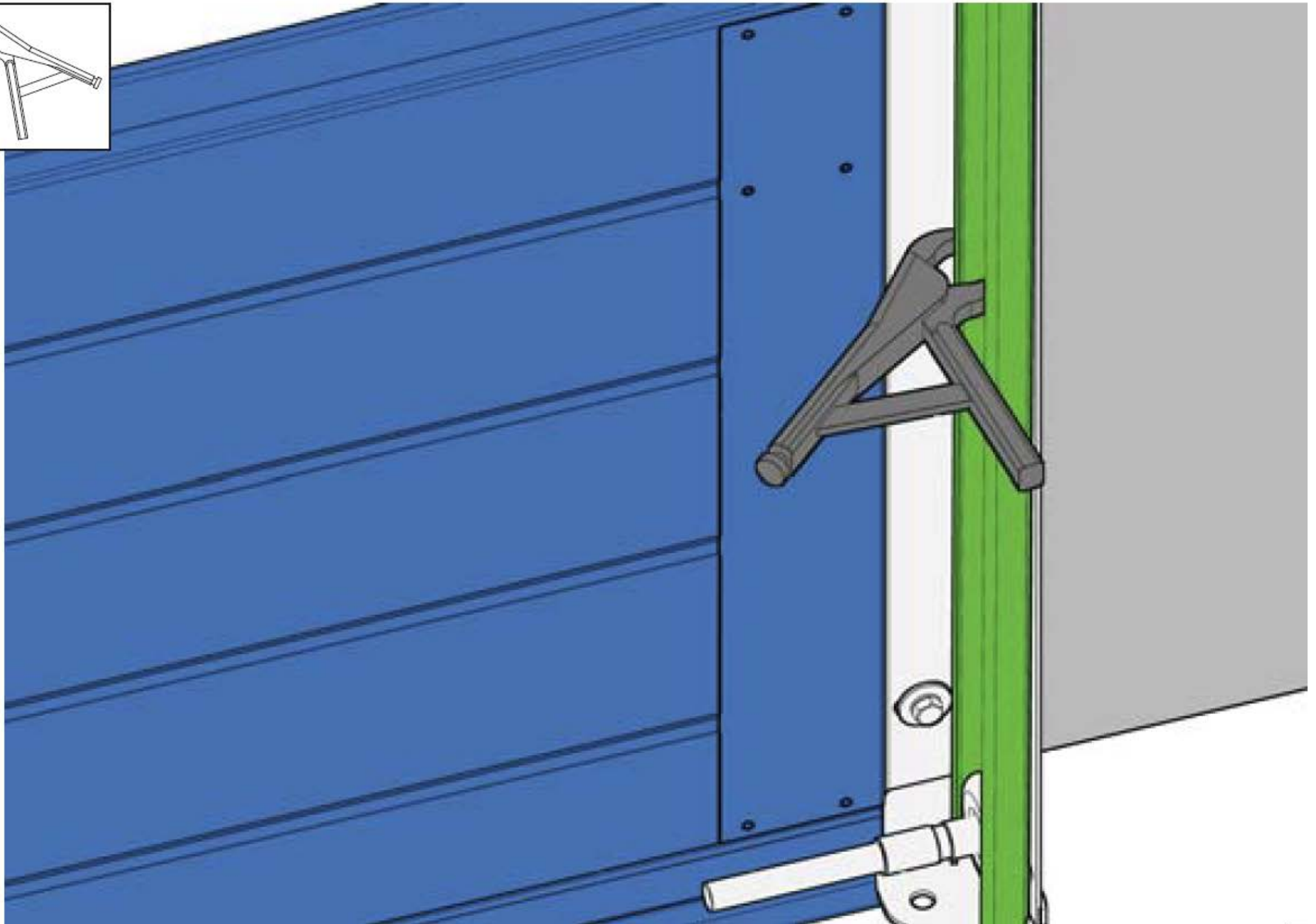

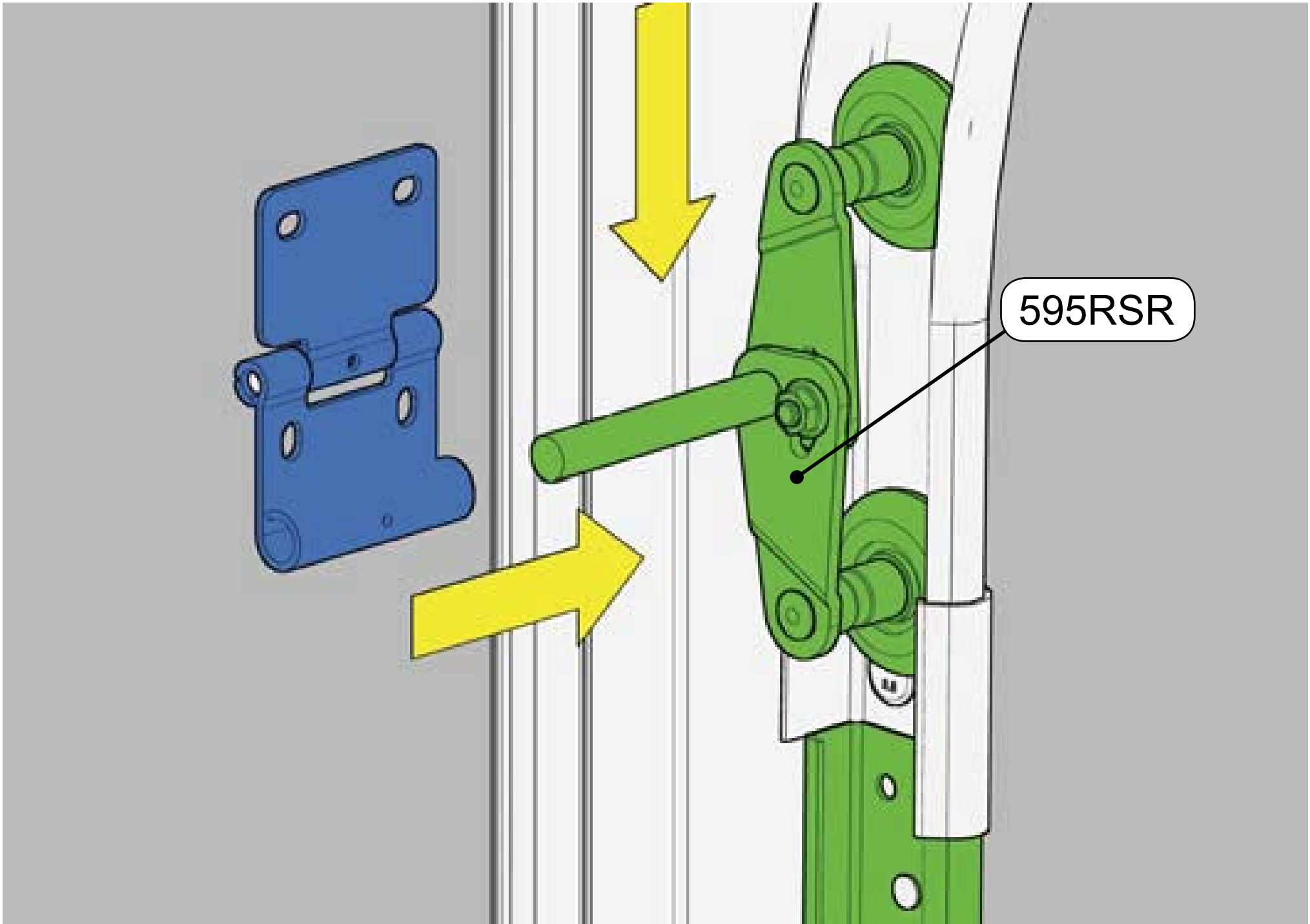

595RSR

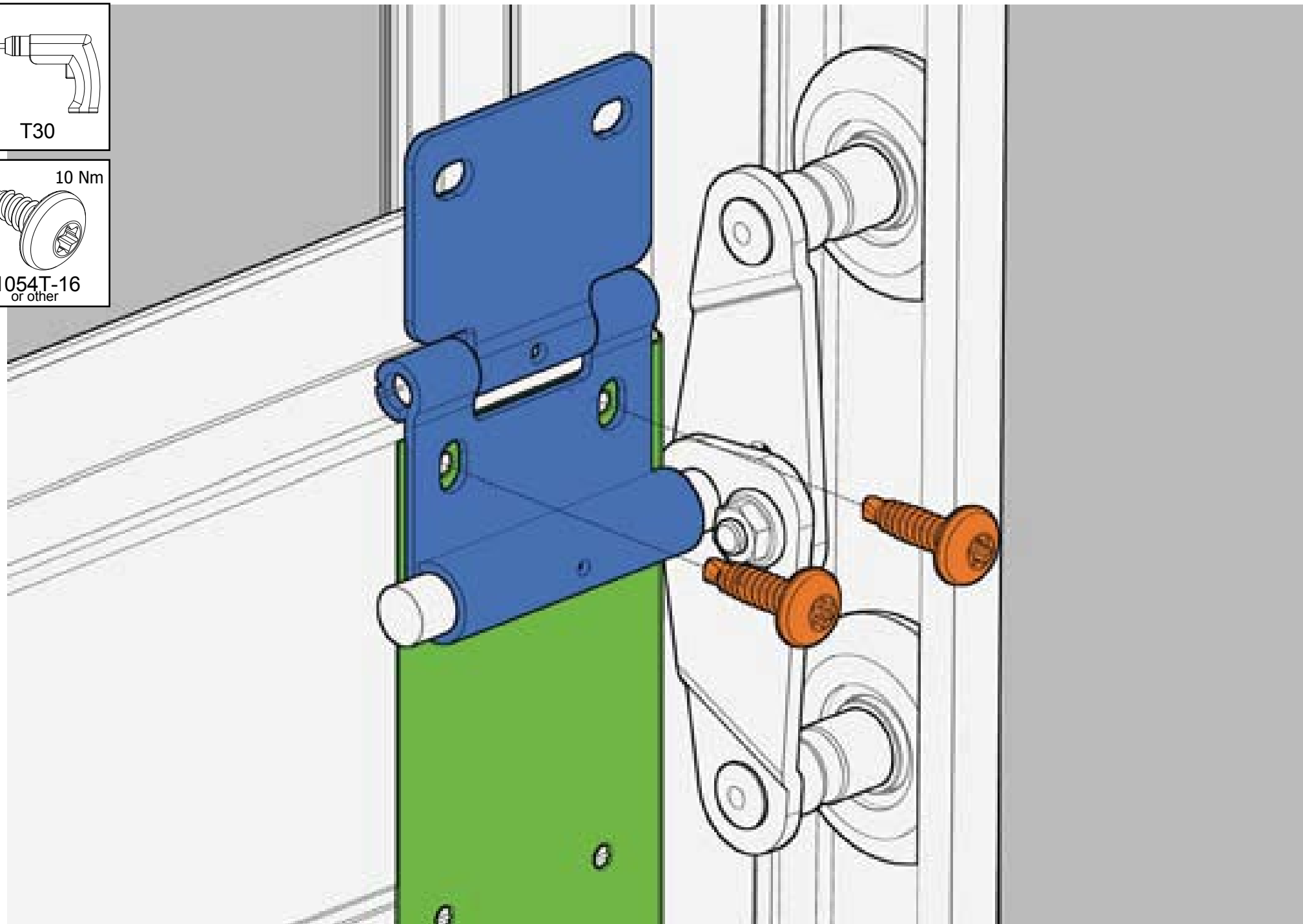
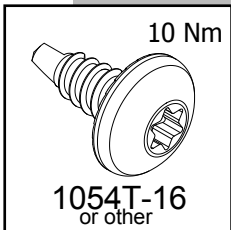
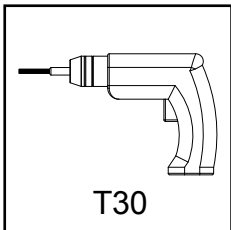

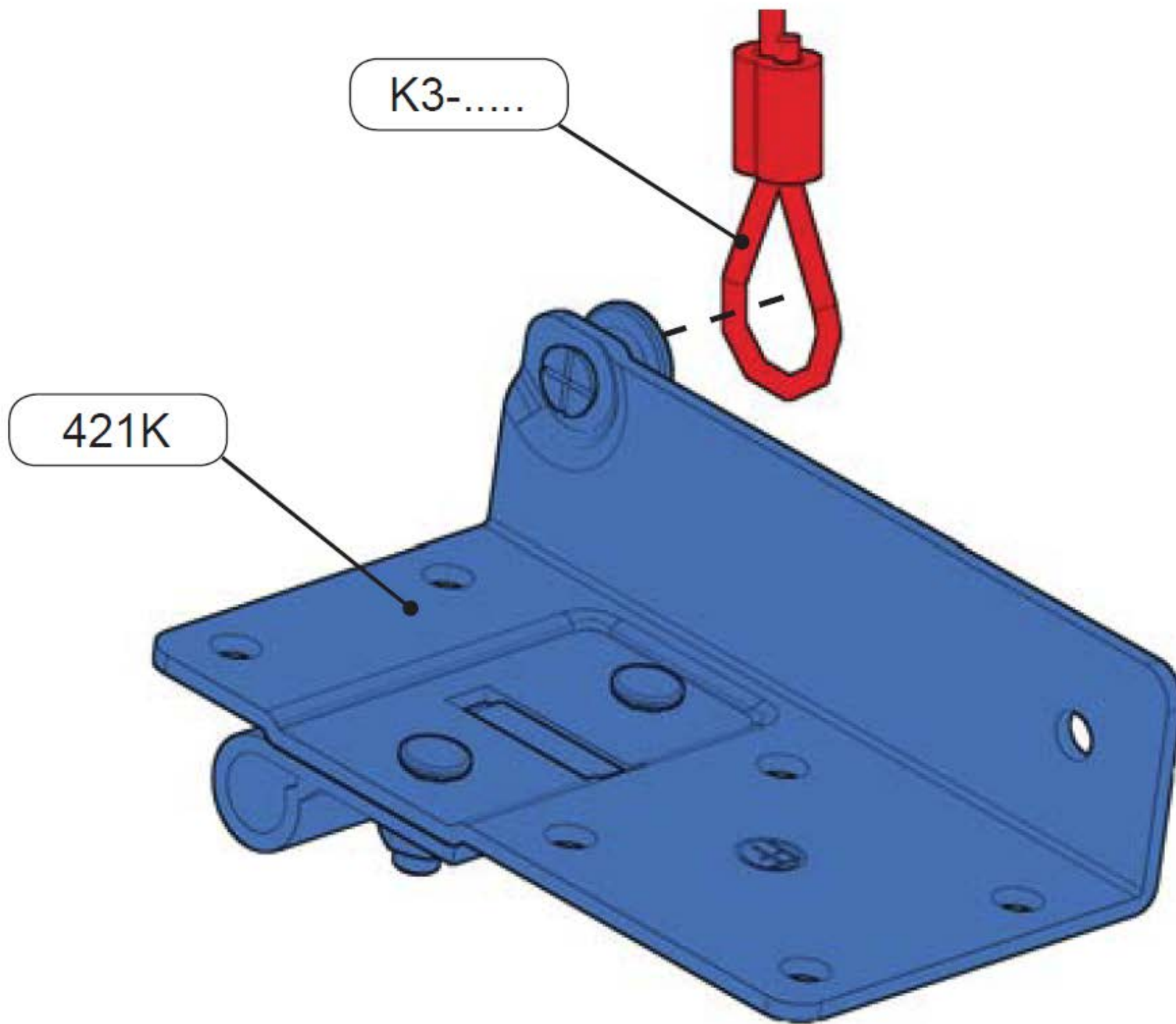

K3-.....

421K



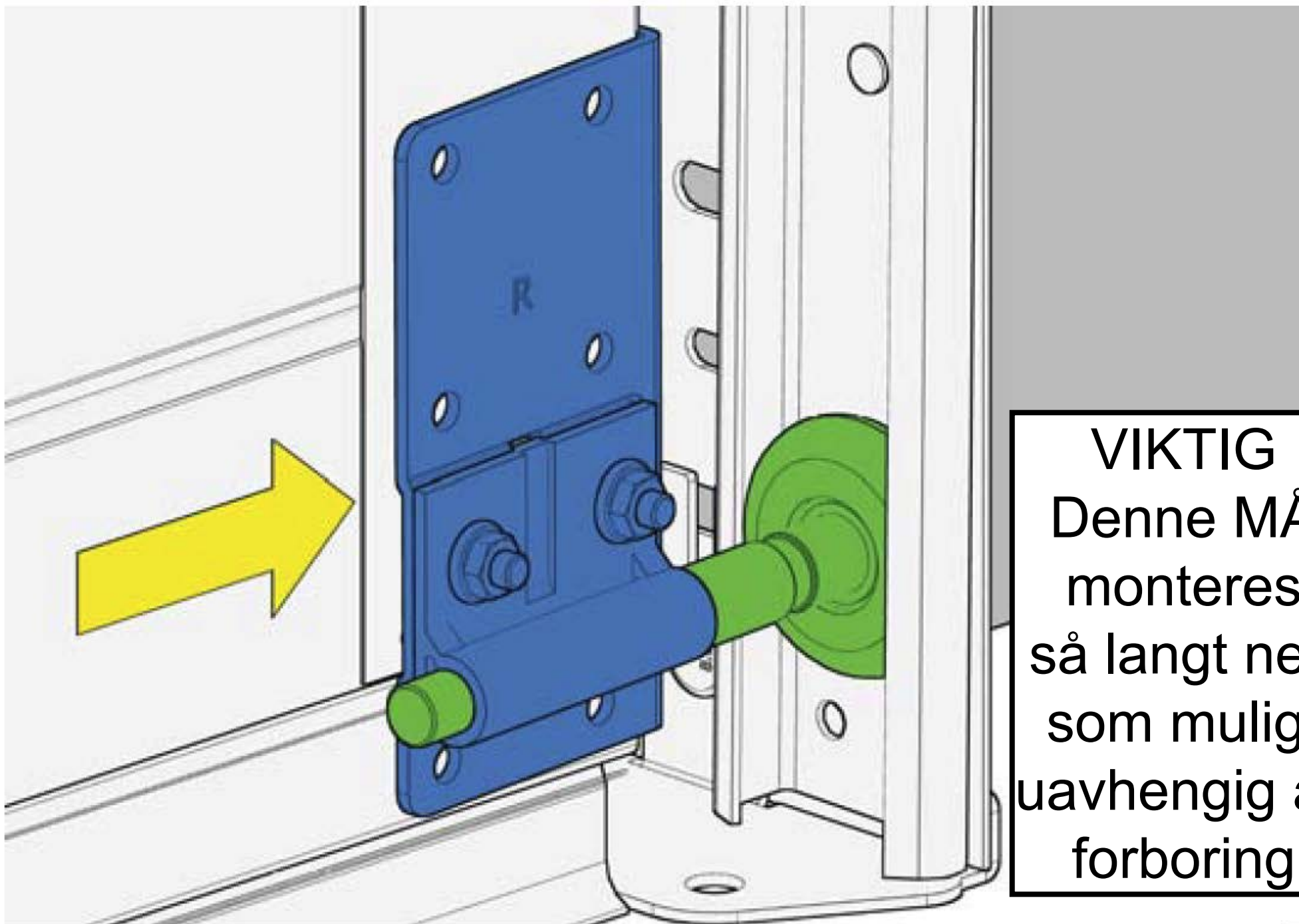

**VIKTIG**  
Denne MÅ monteres så langt ned som mulig, uavhengig av forboring

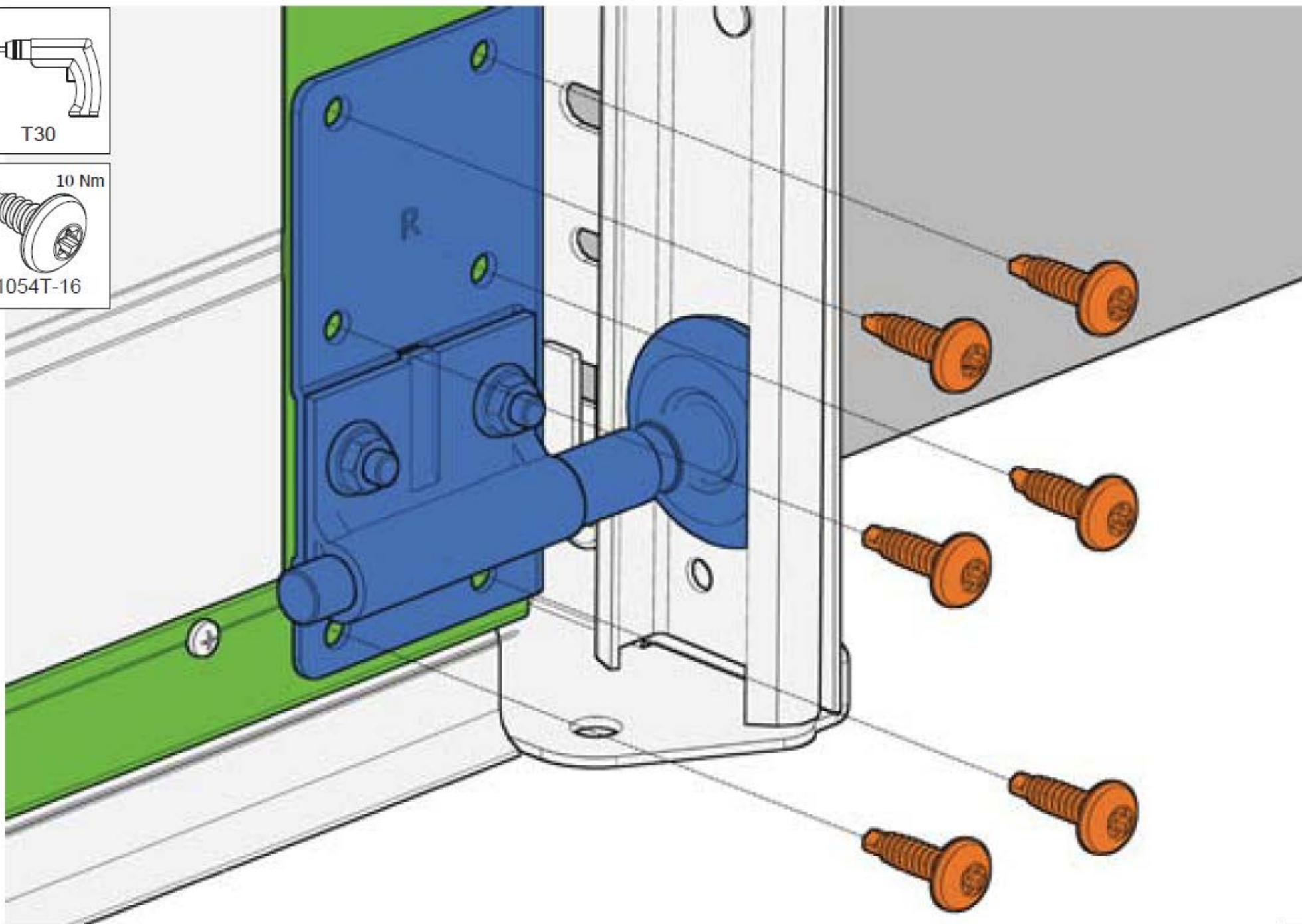
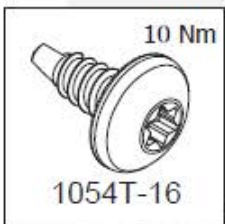
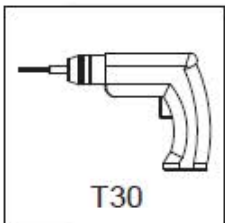

# VIKTIG!

Montering av elementene MA  
gjøres i denne rekkefølgen  
FØR montering av hengsler!

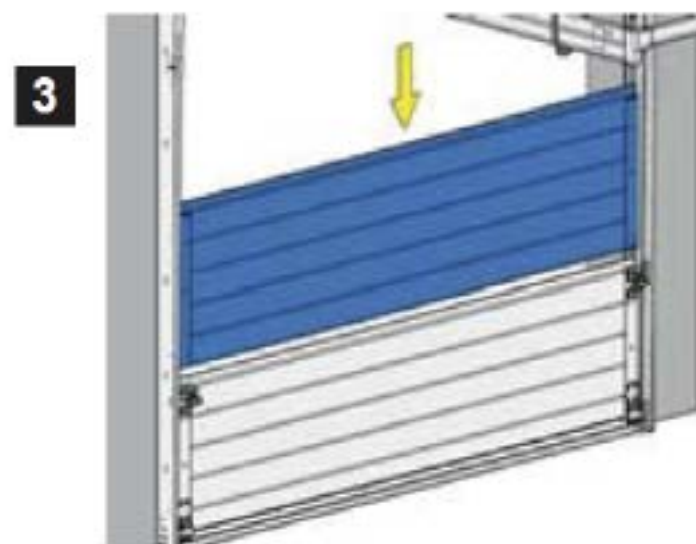
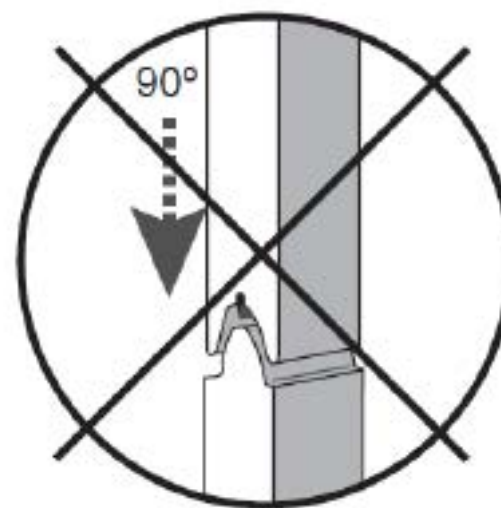
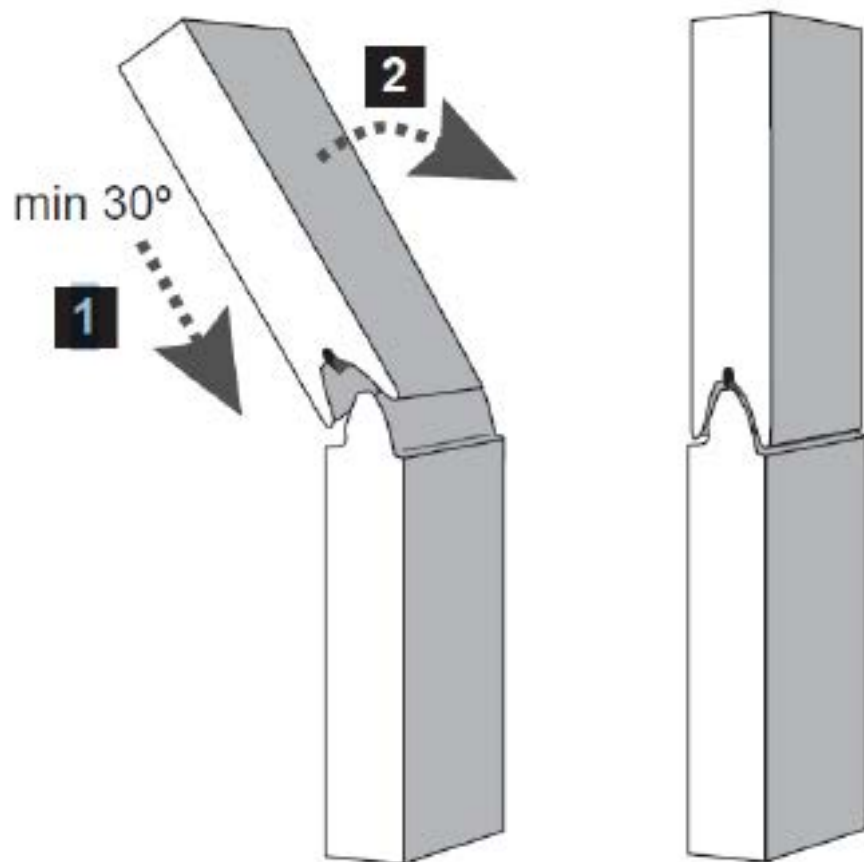

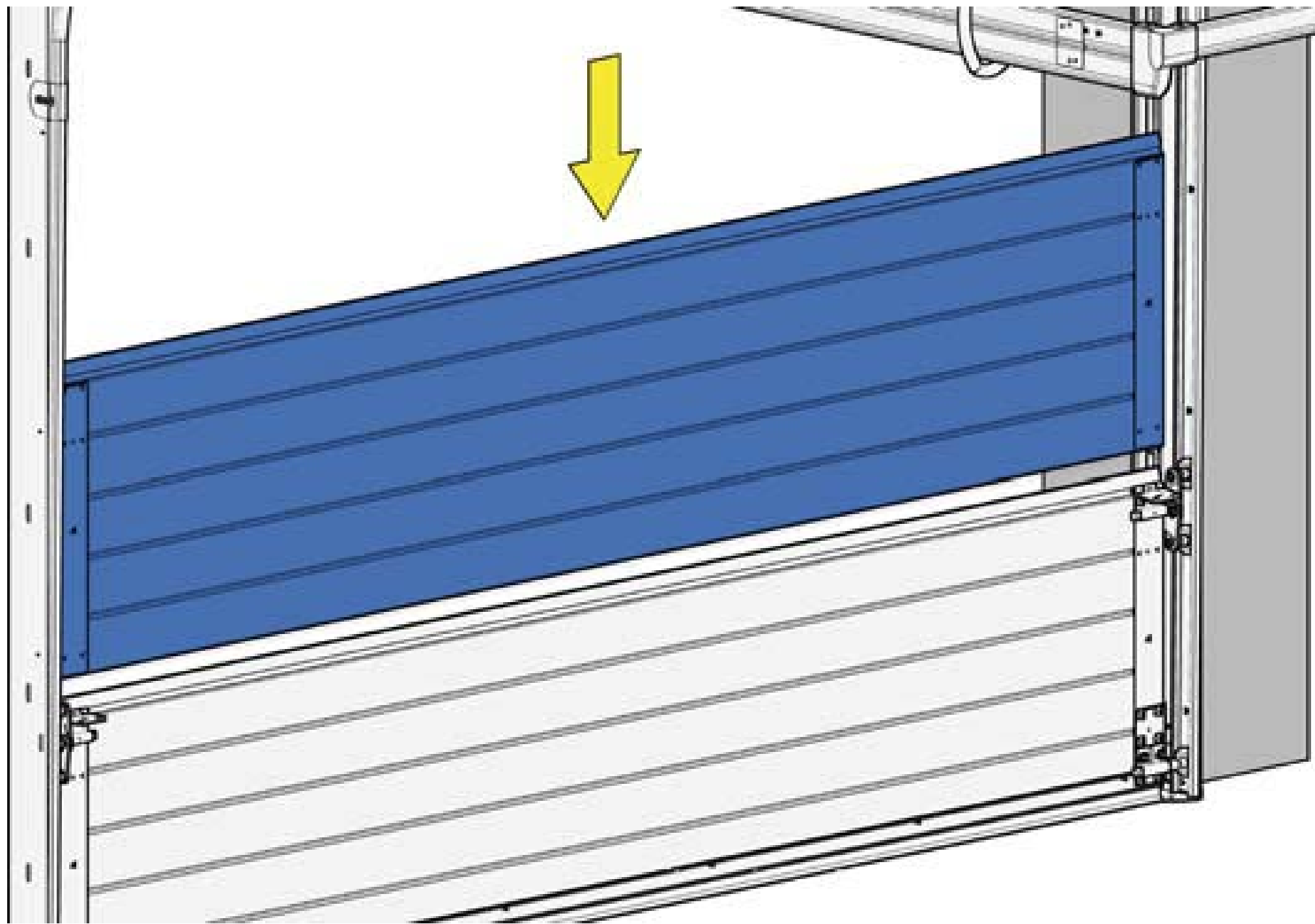

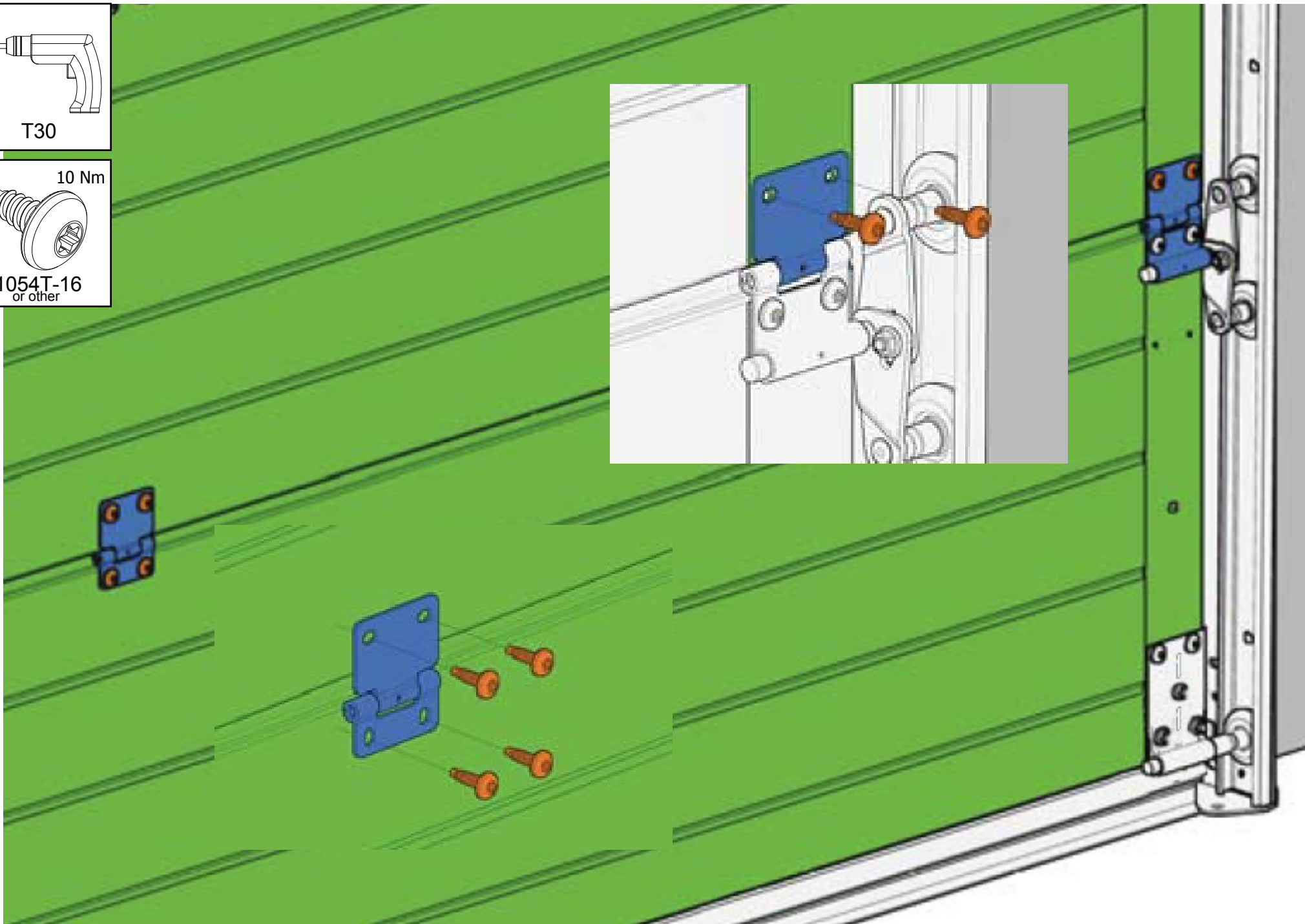
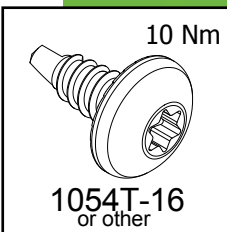
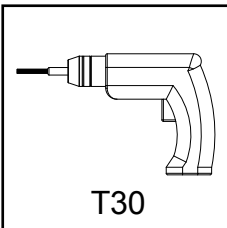

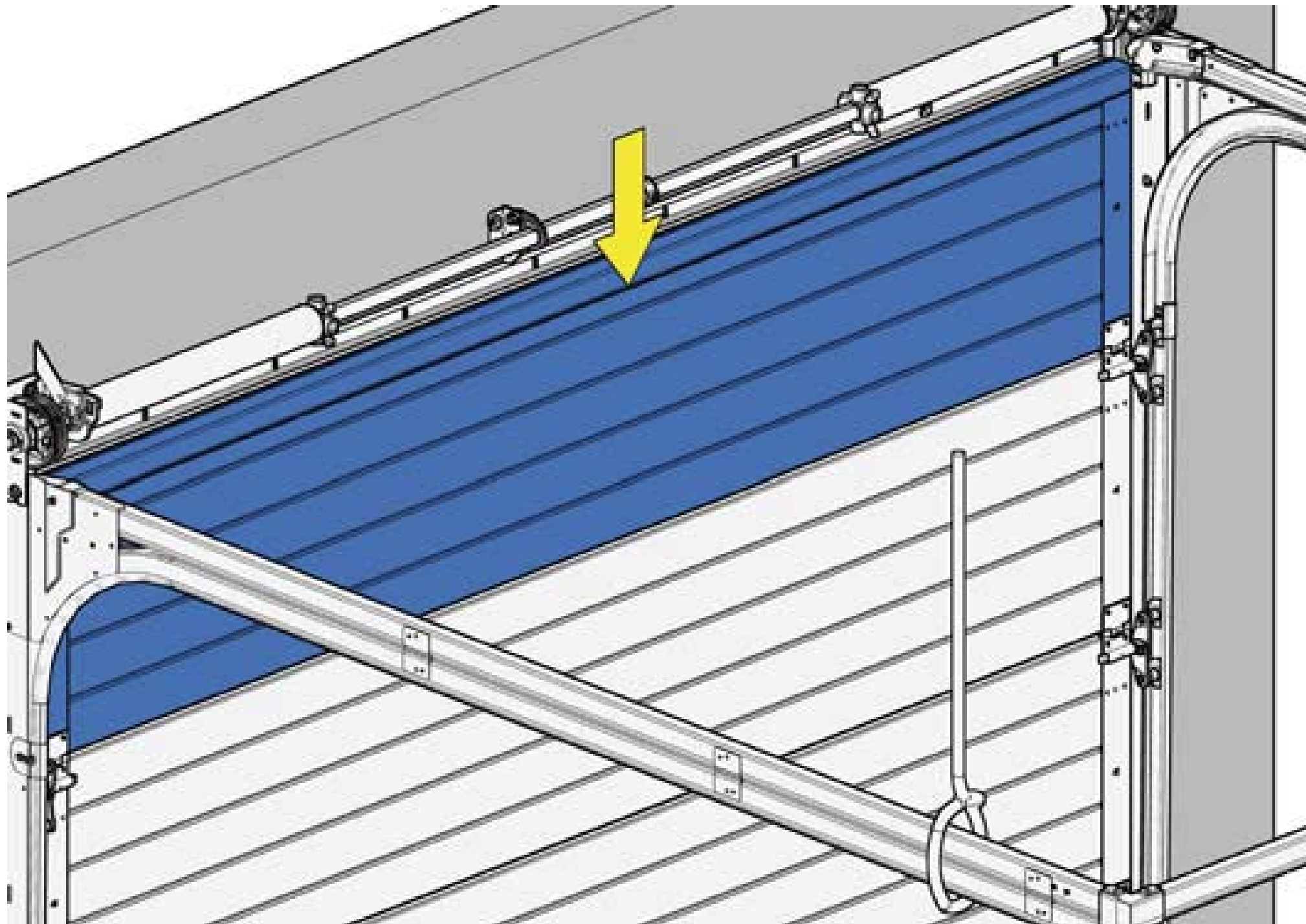

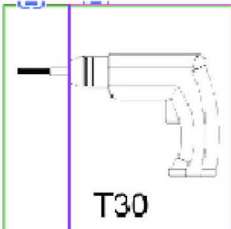

T30

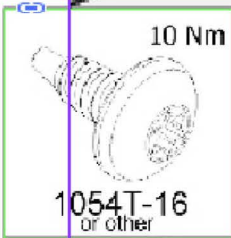

10 Nm

1054T-16  
Or Other

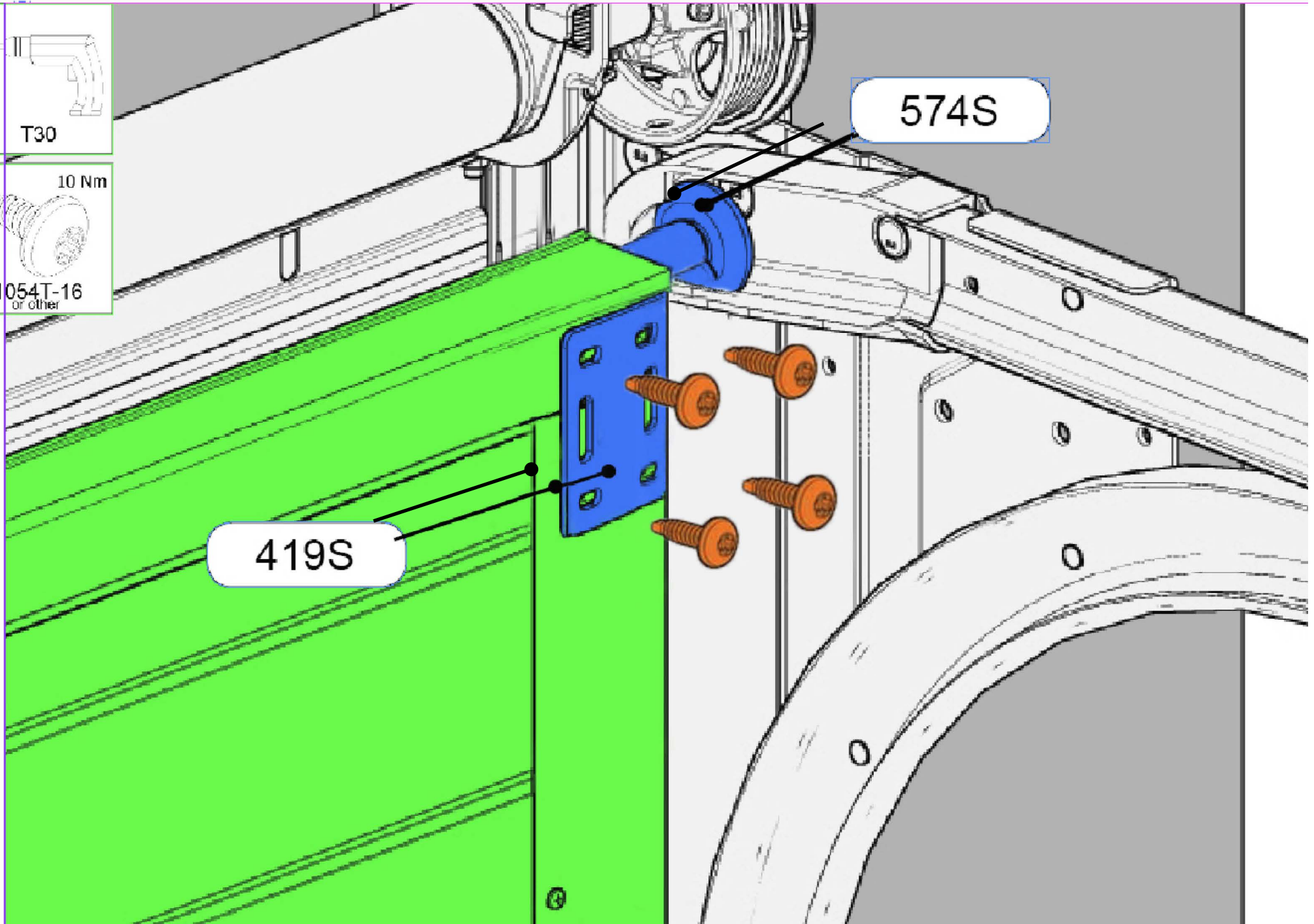

574S

419S

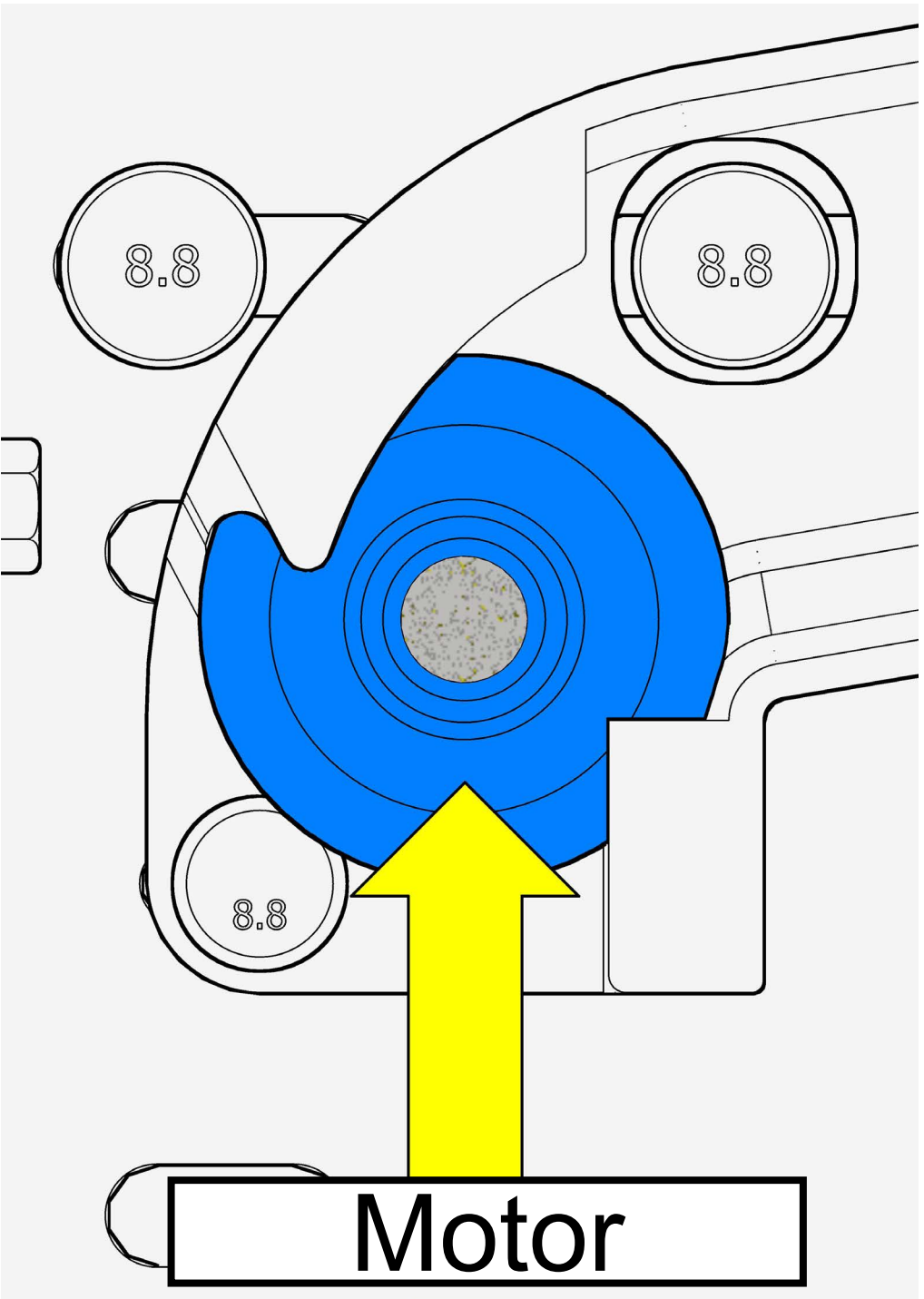
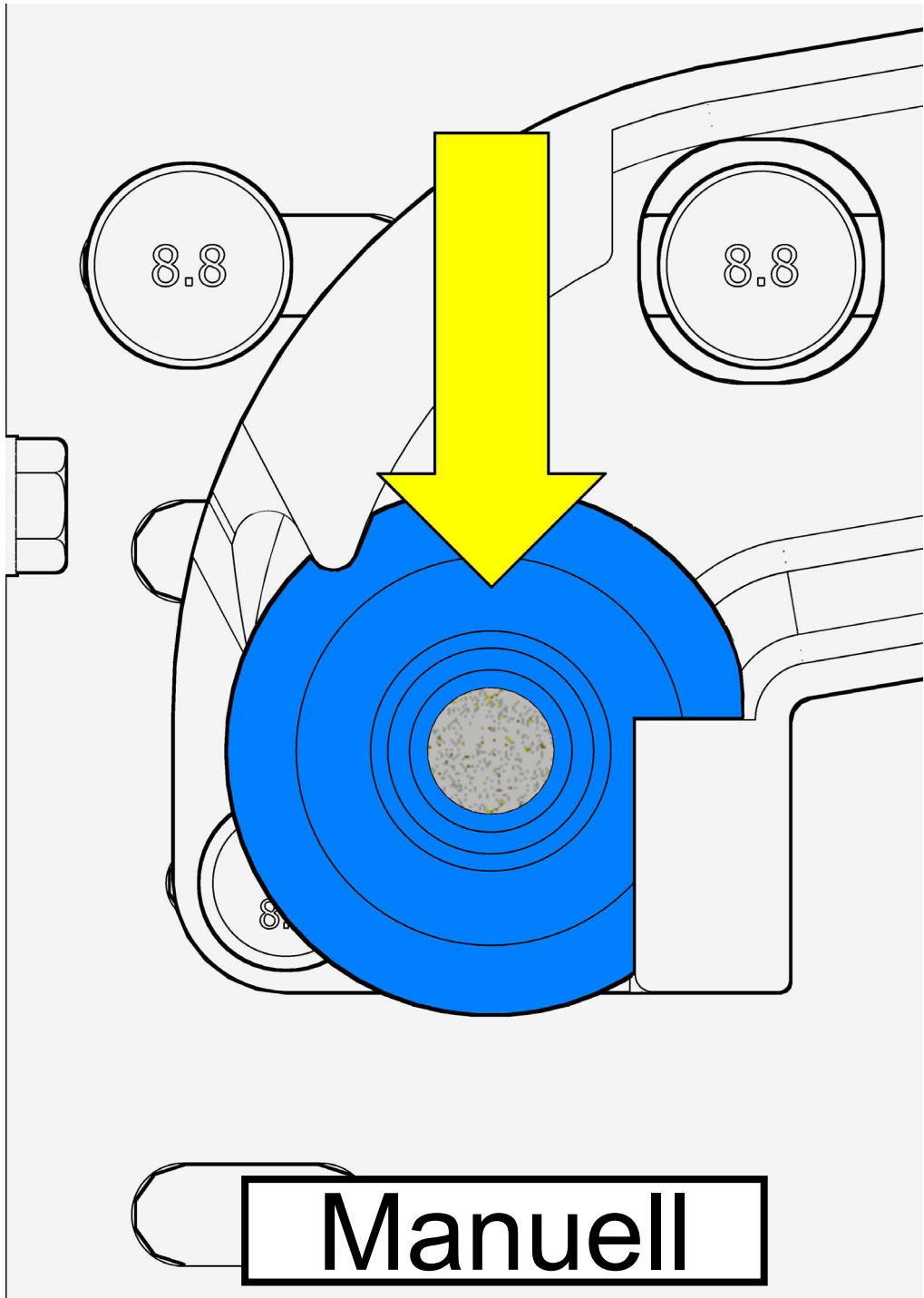



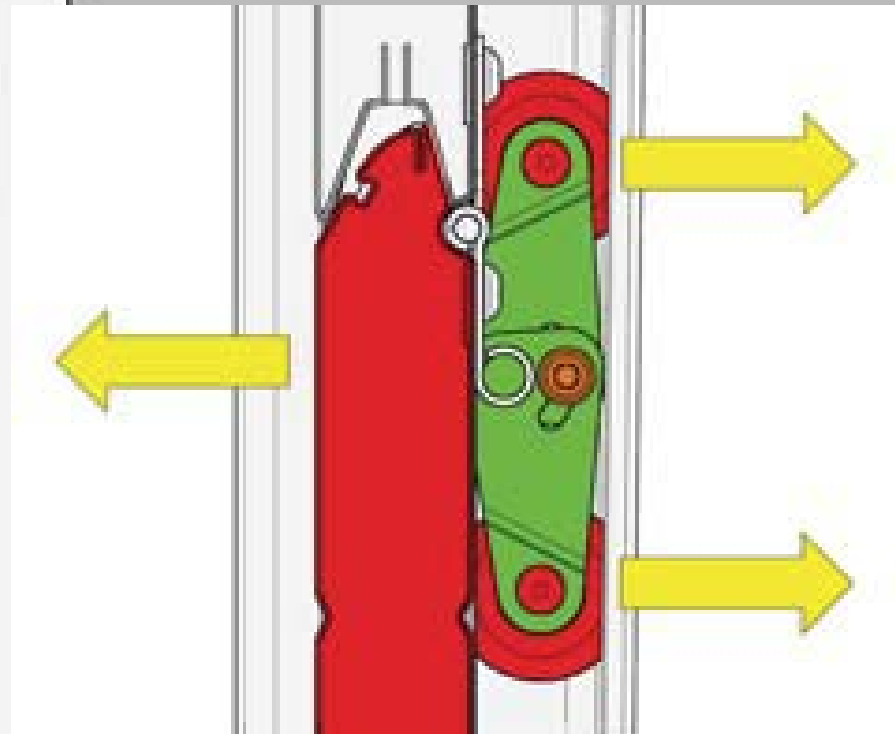
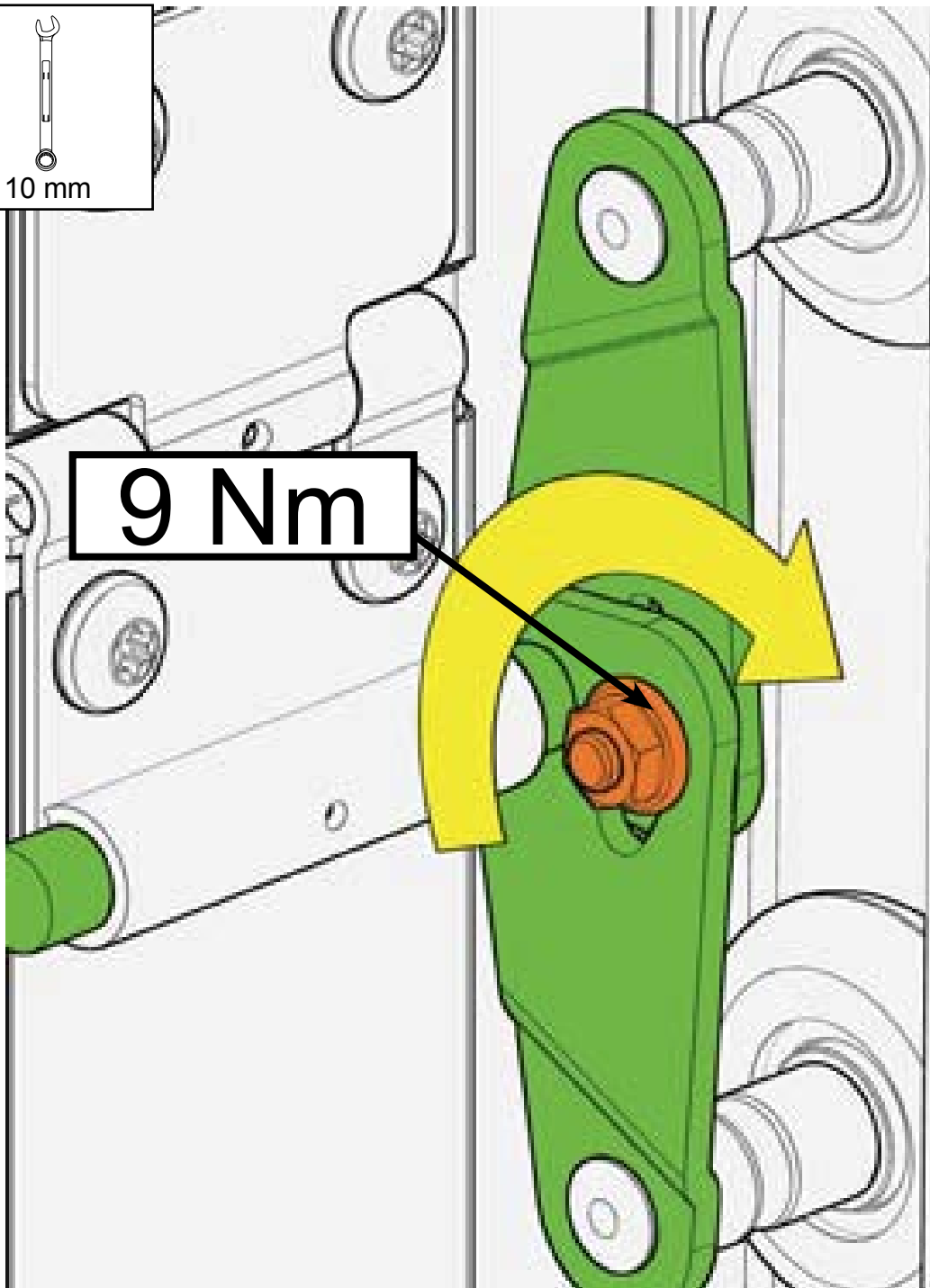
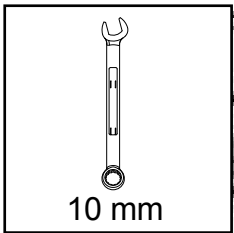

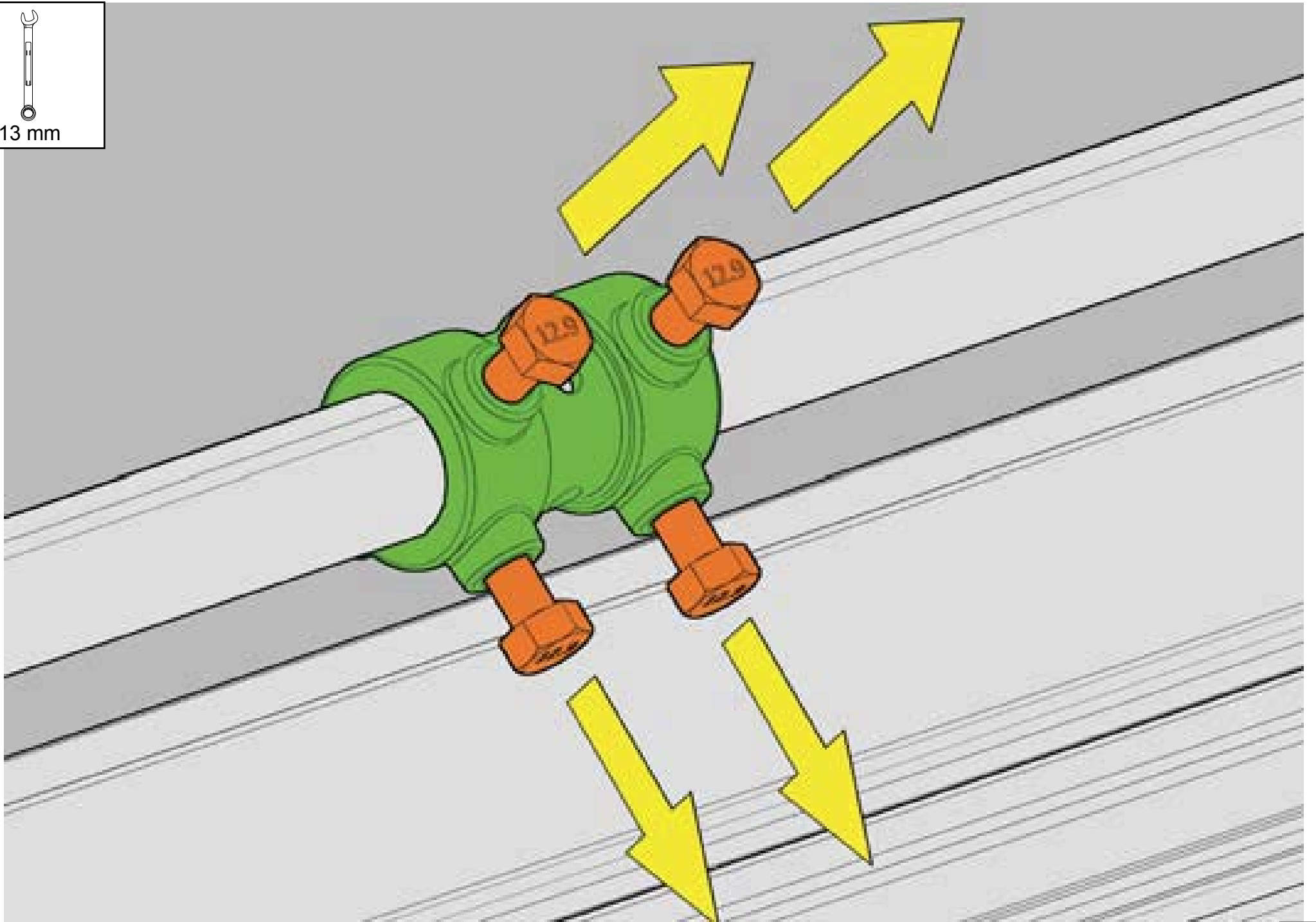
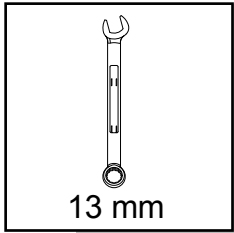

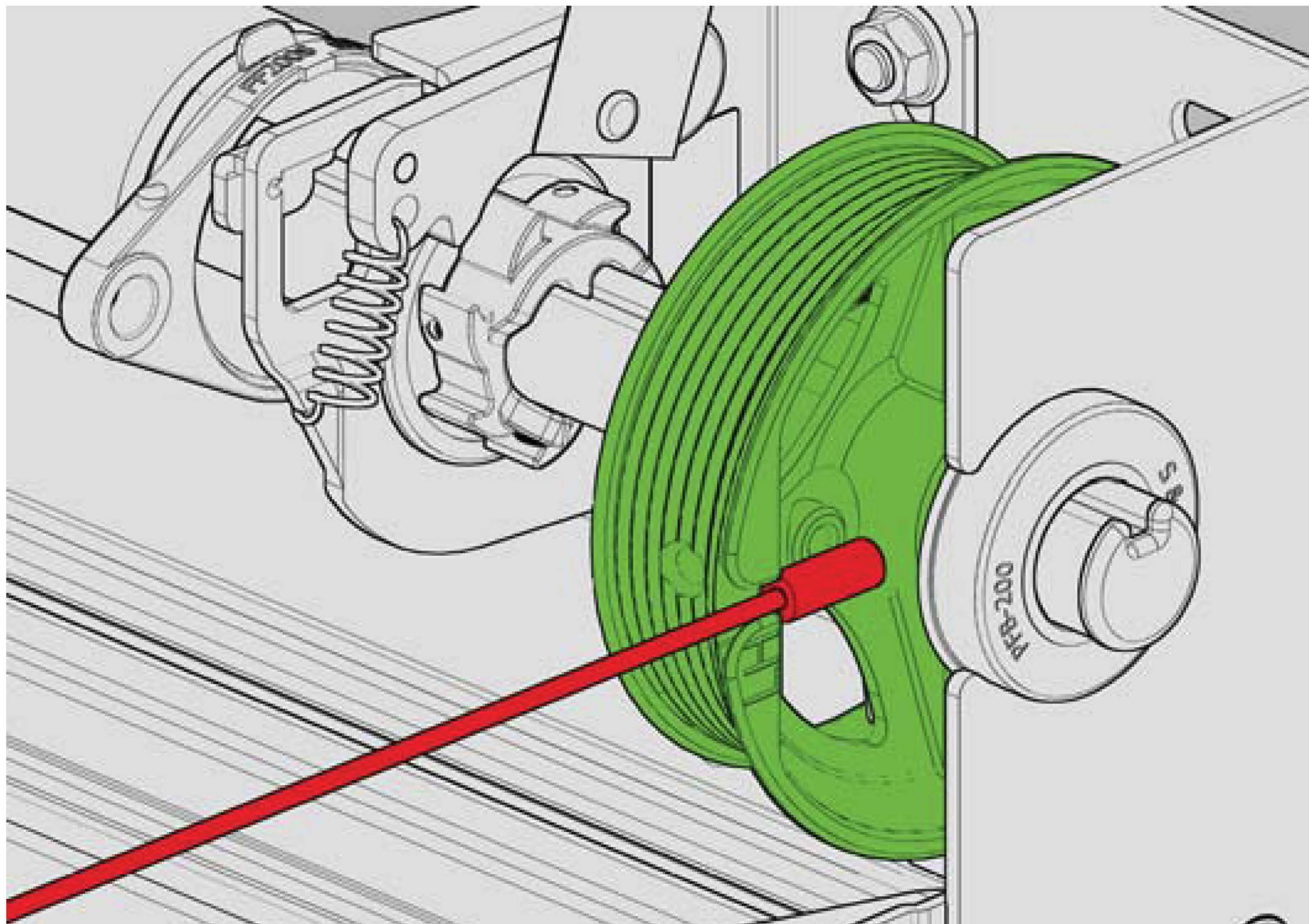

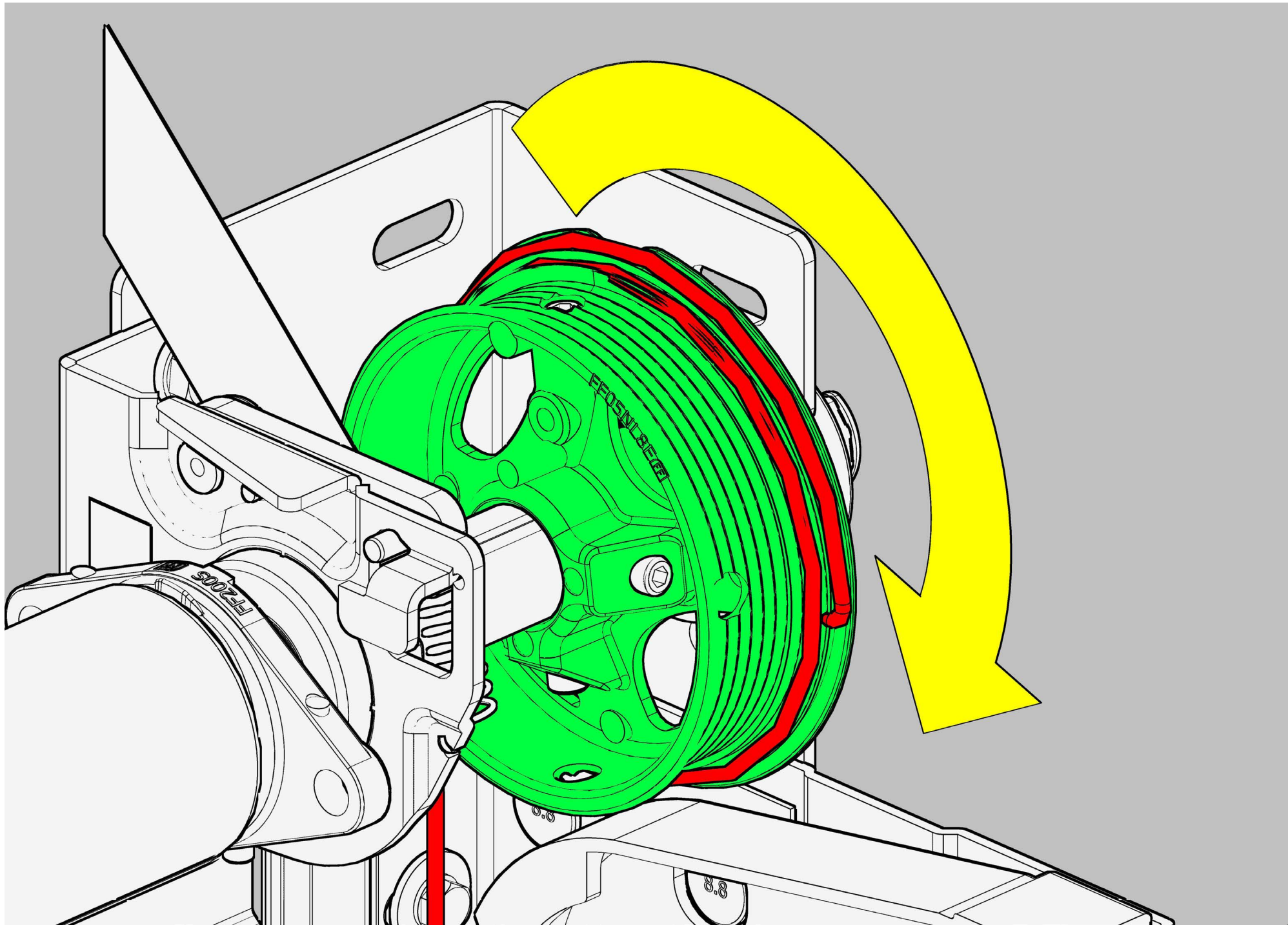

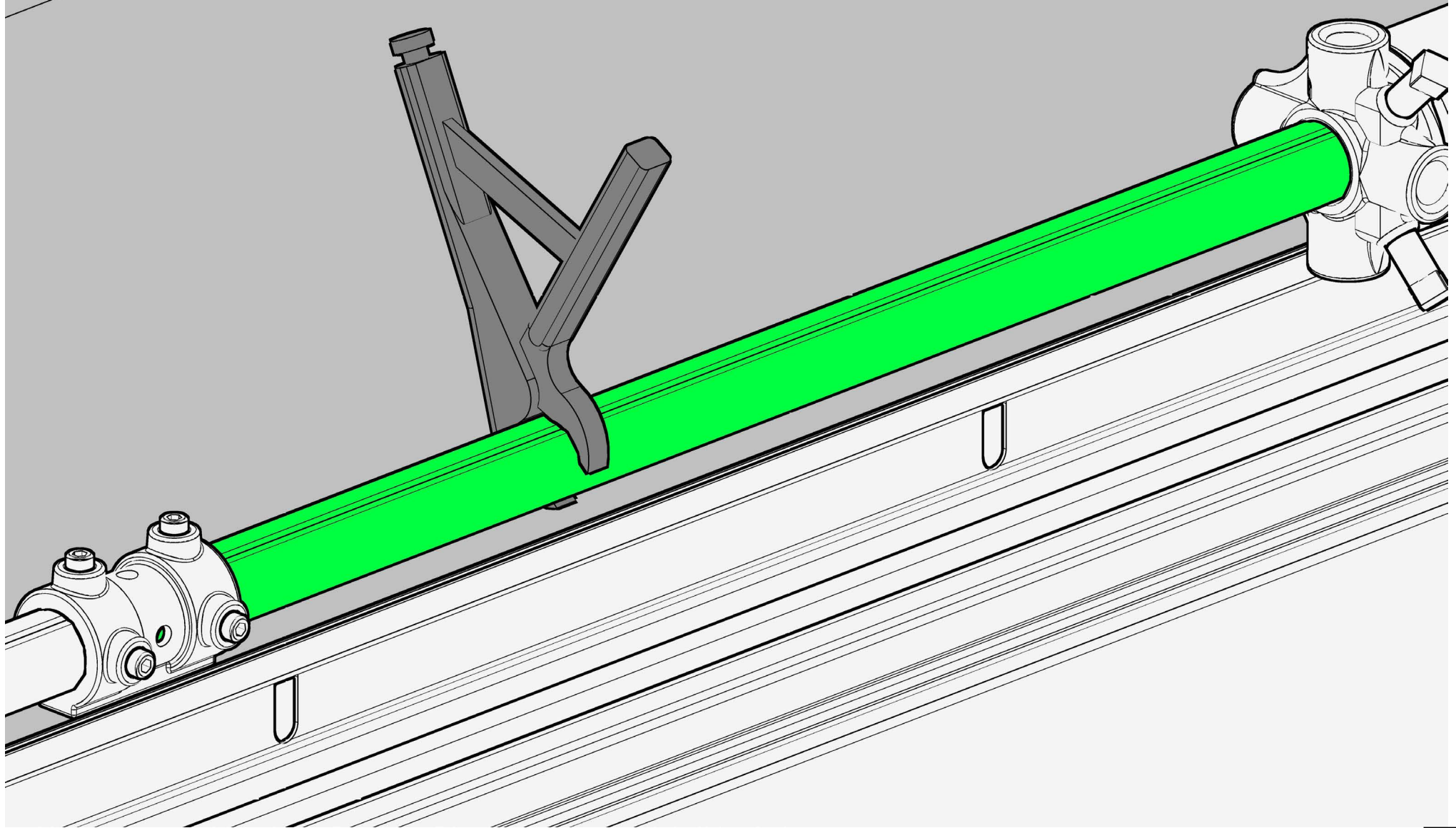
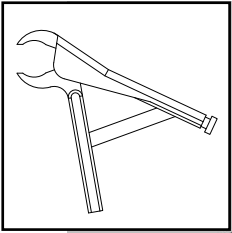

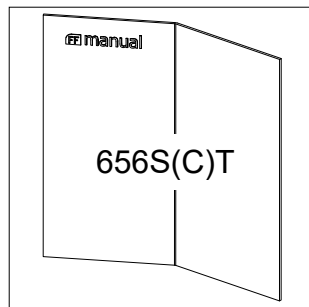
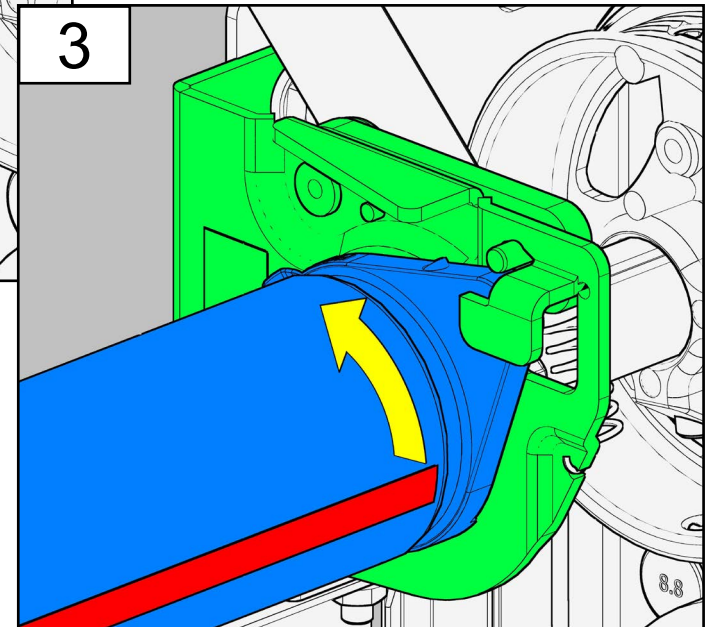
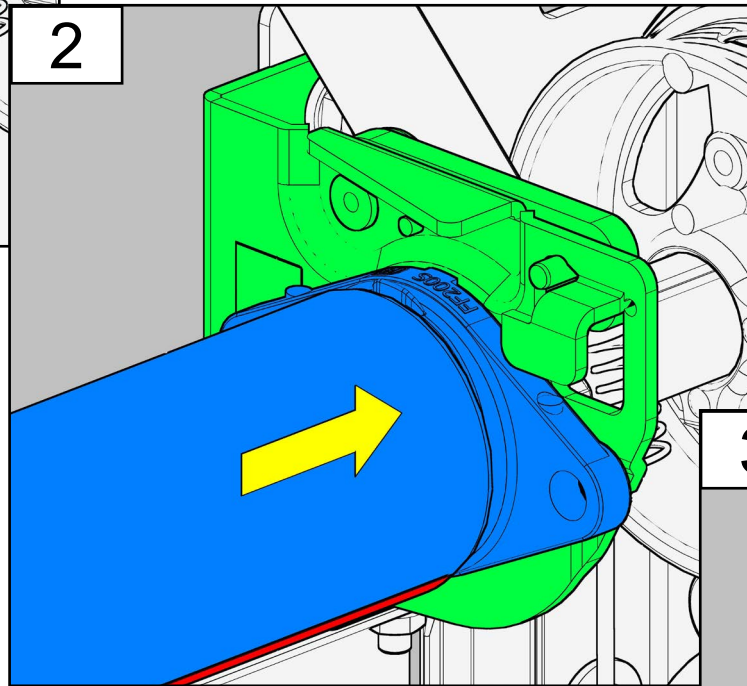
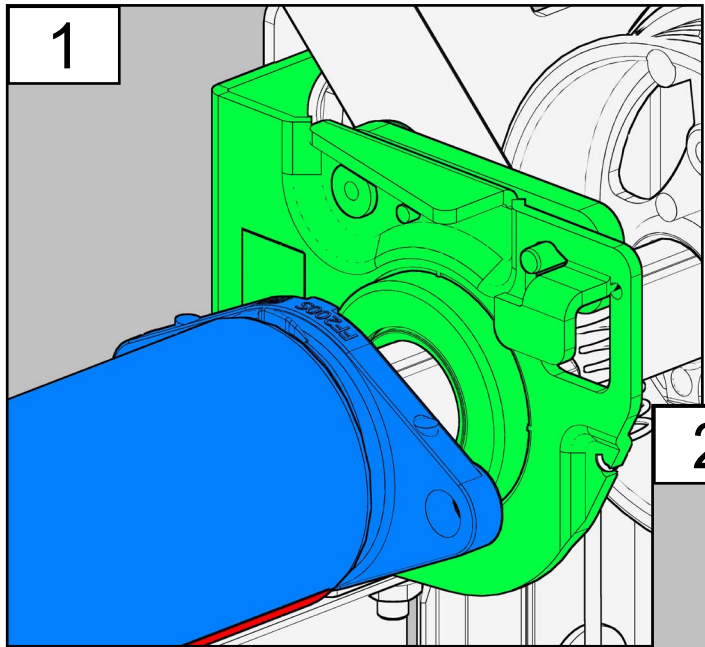

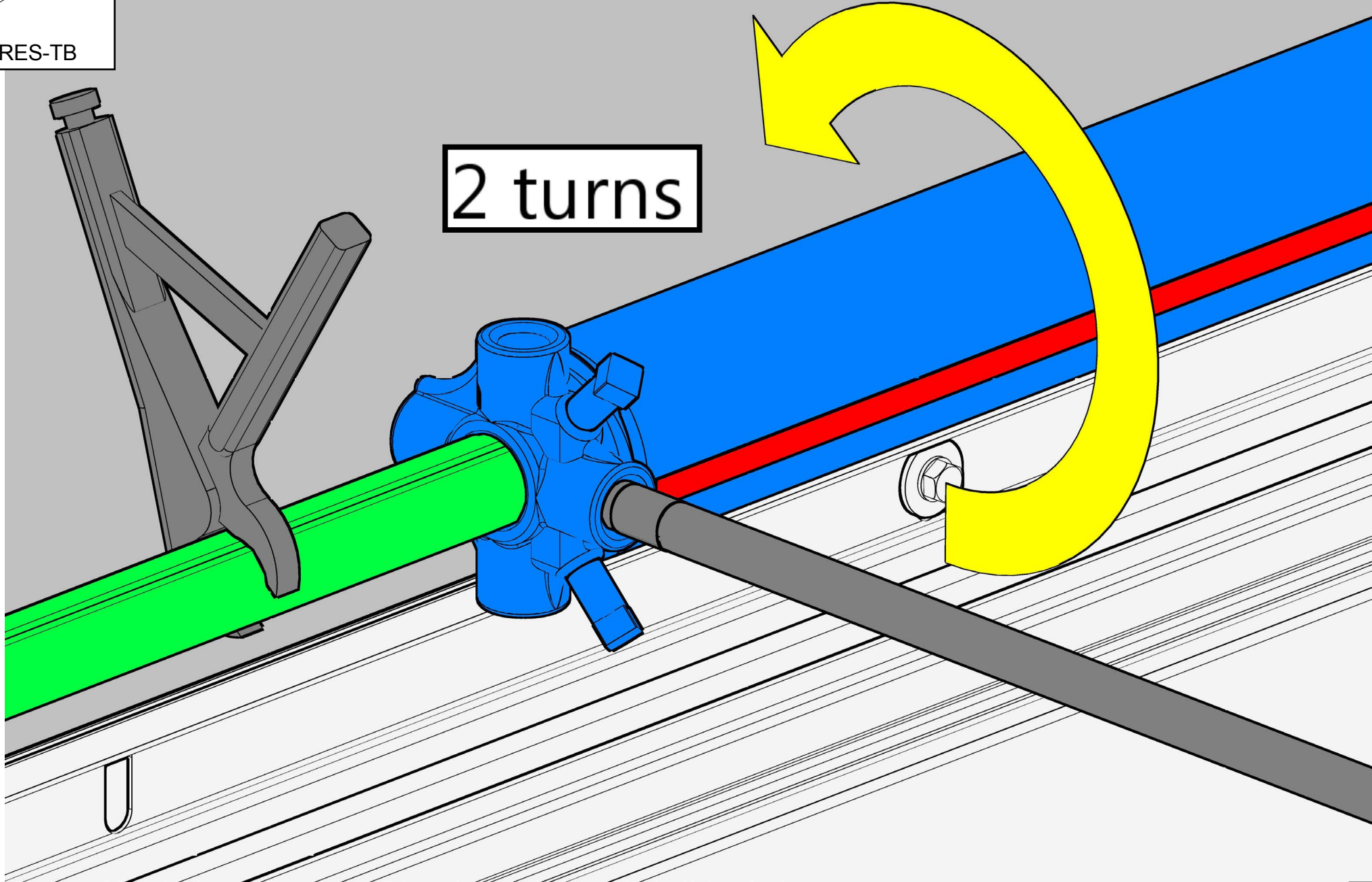
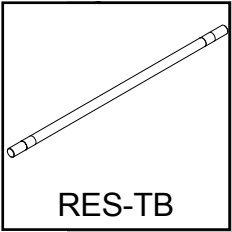

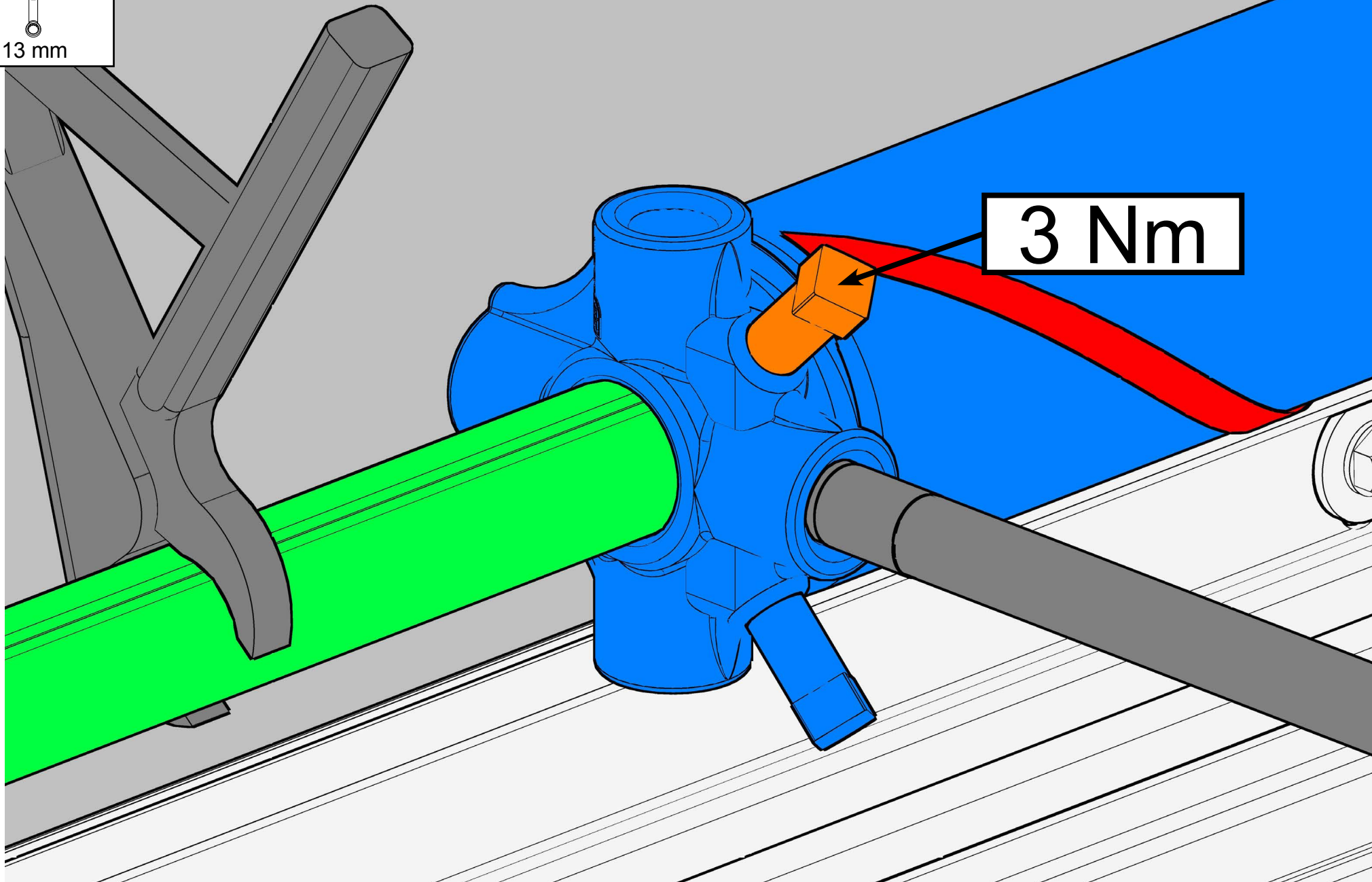
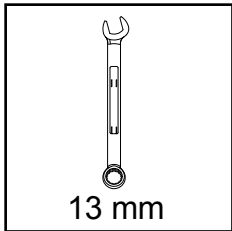



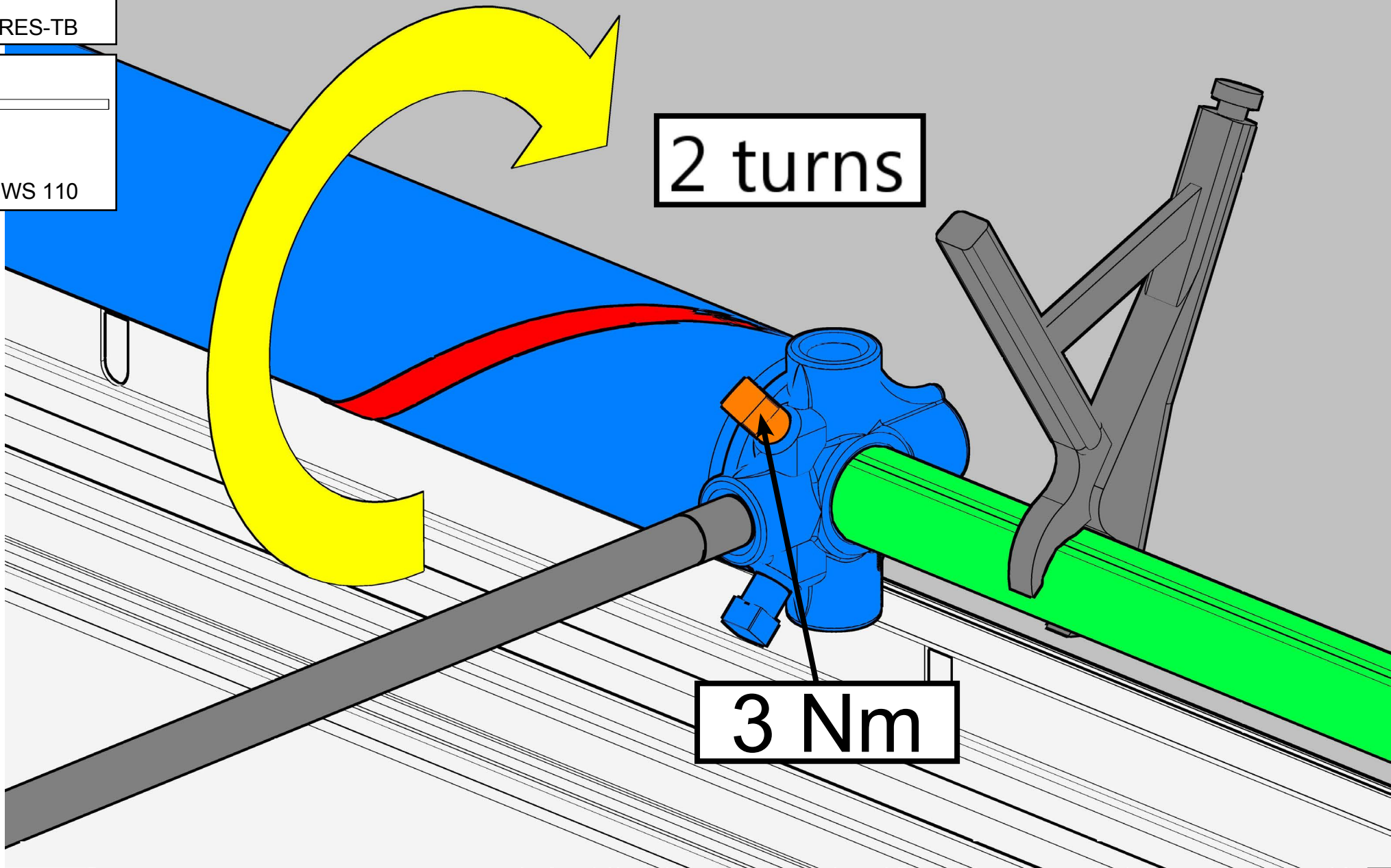
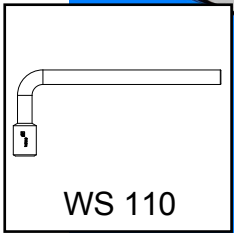
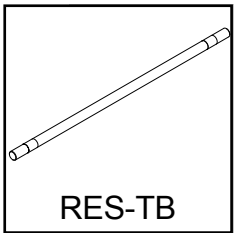

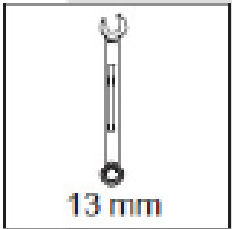

10 Nm

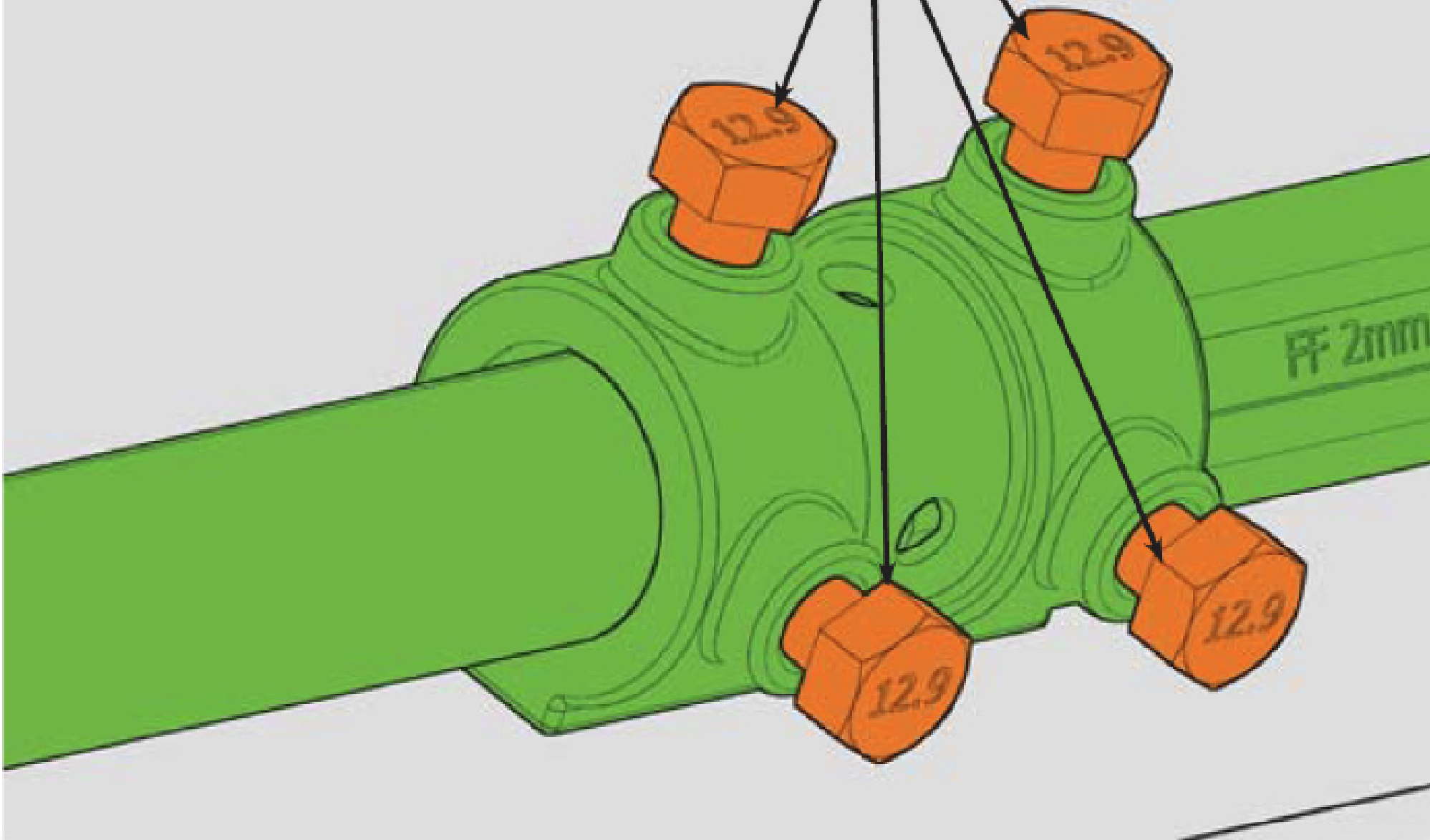

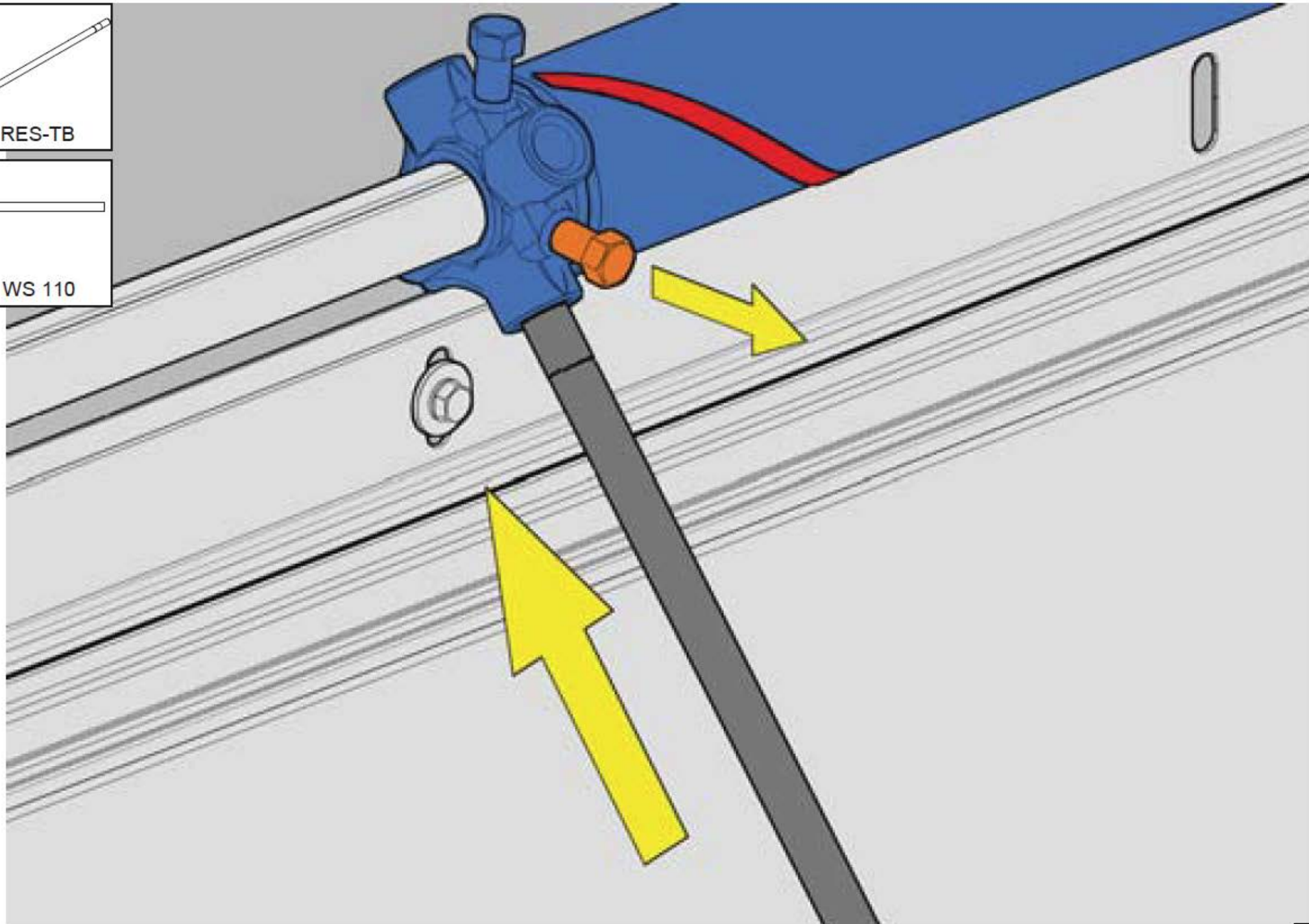
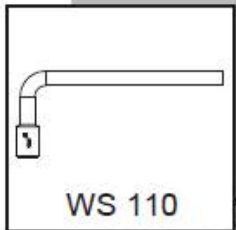
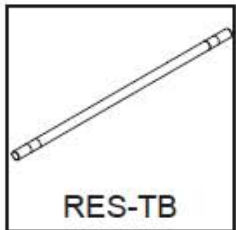

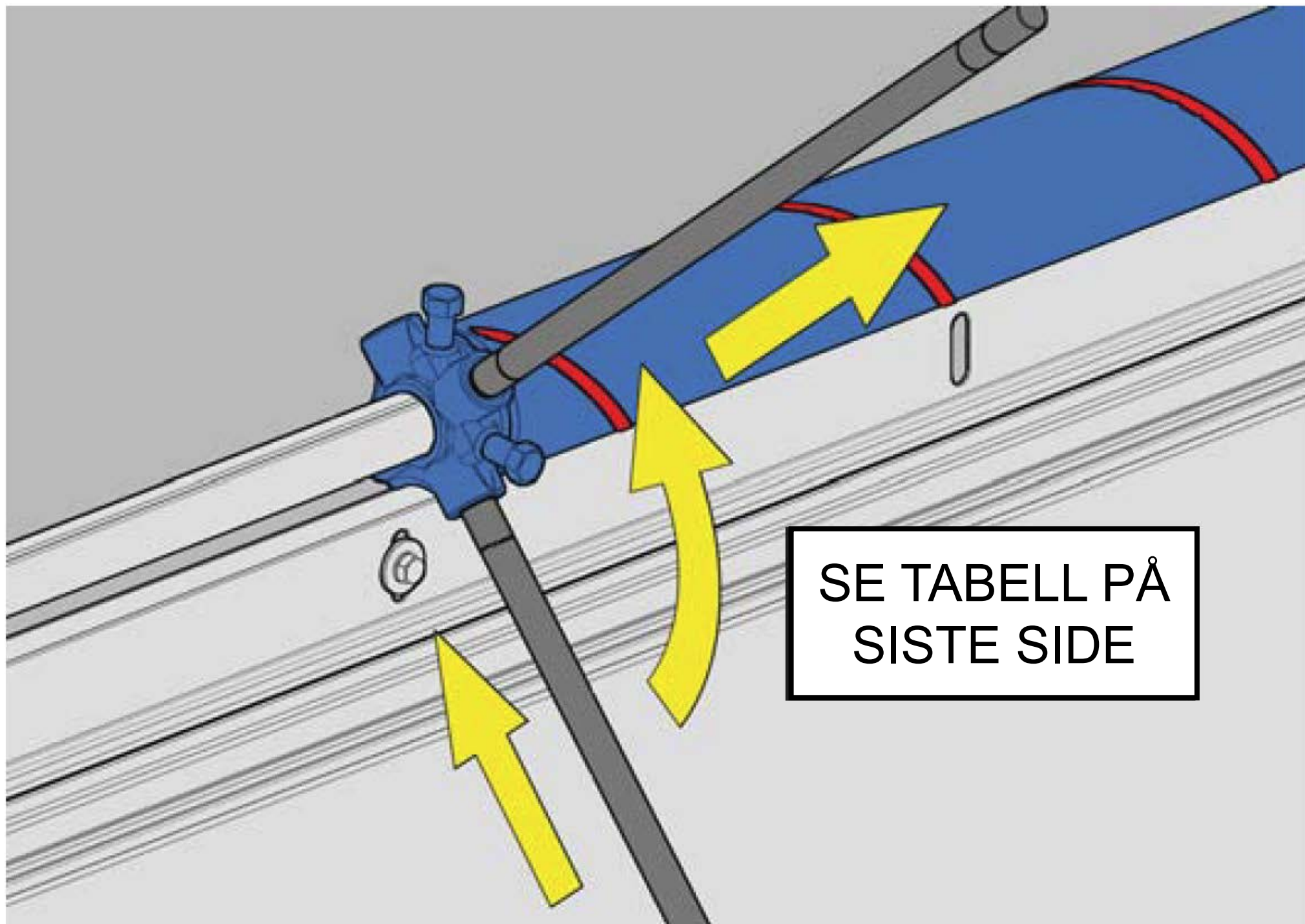

SE TABELL PÅ  
SISTE SIDE

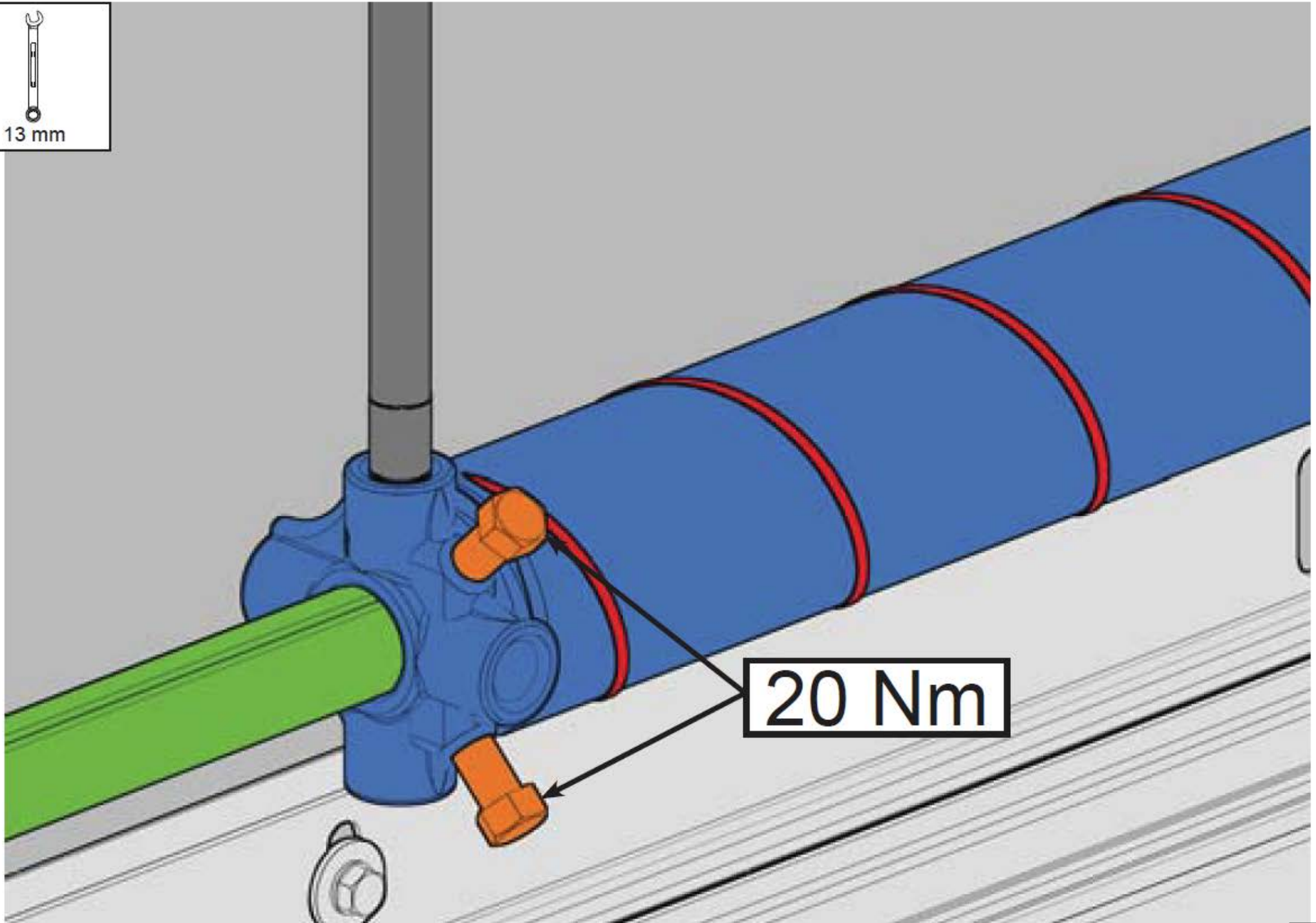
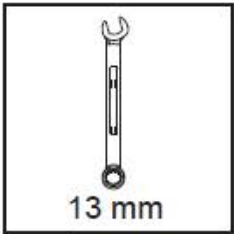

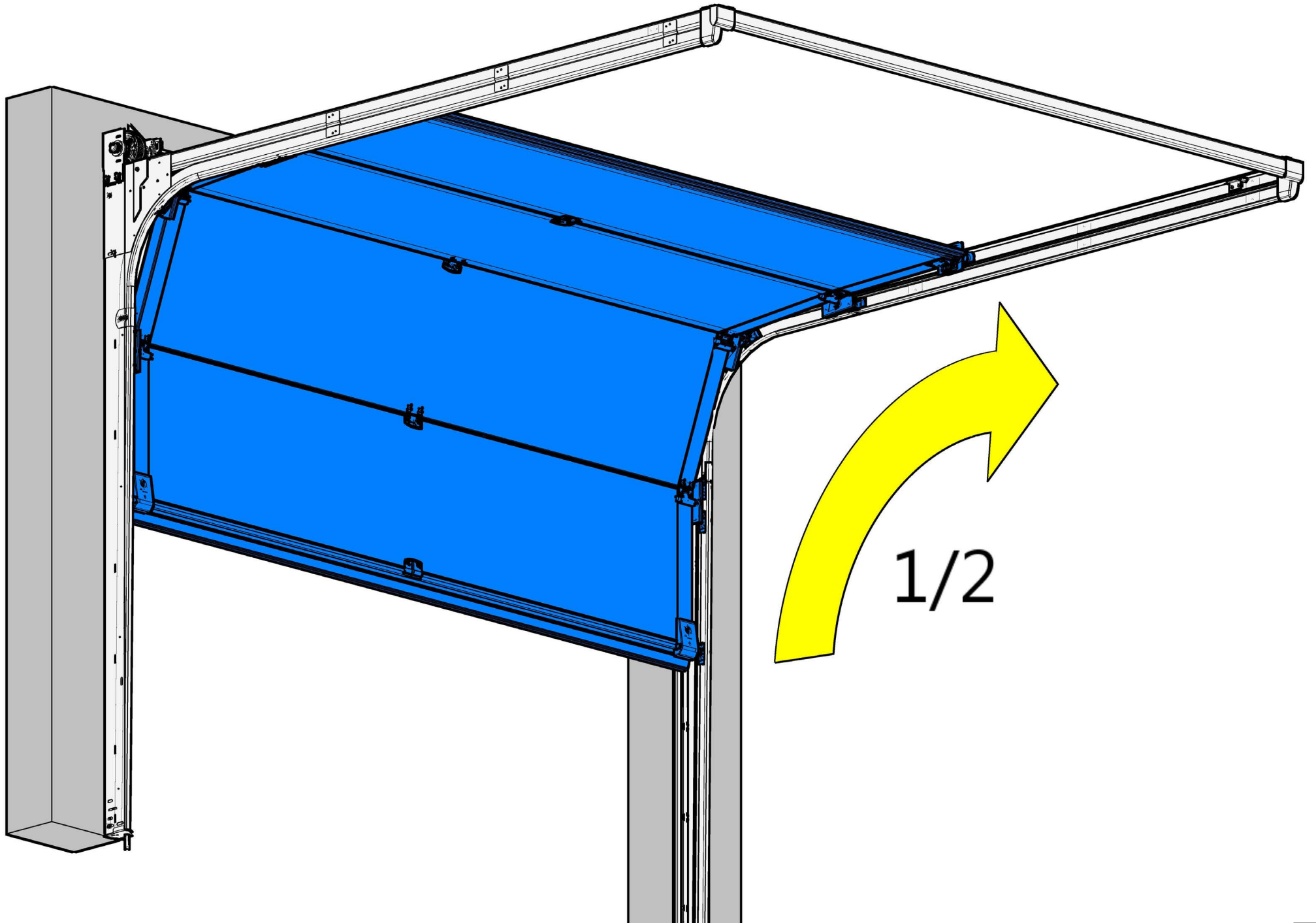

1/2

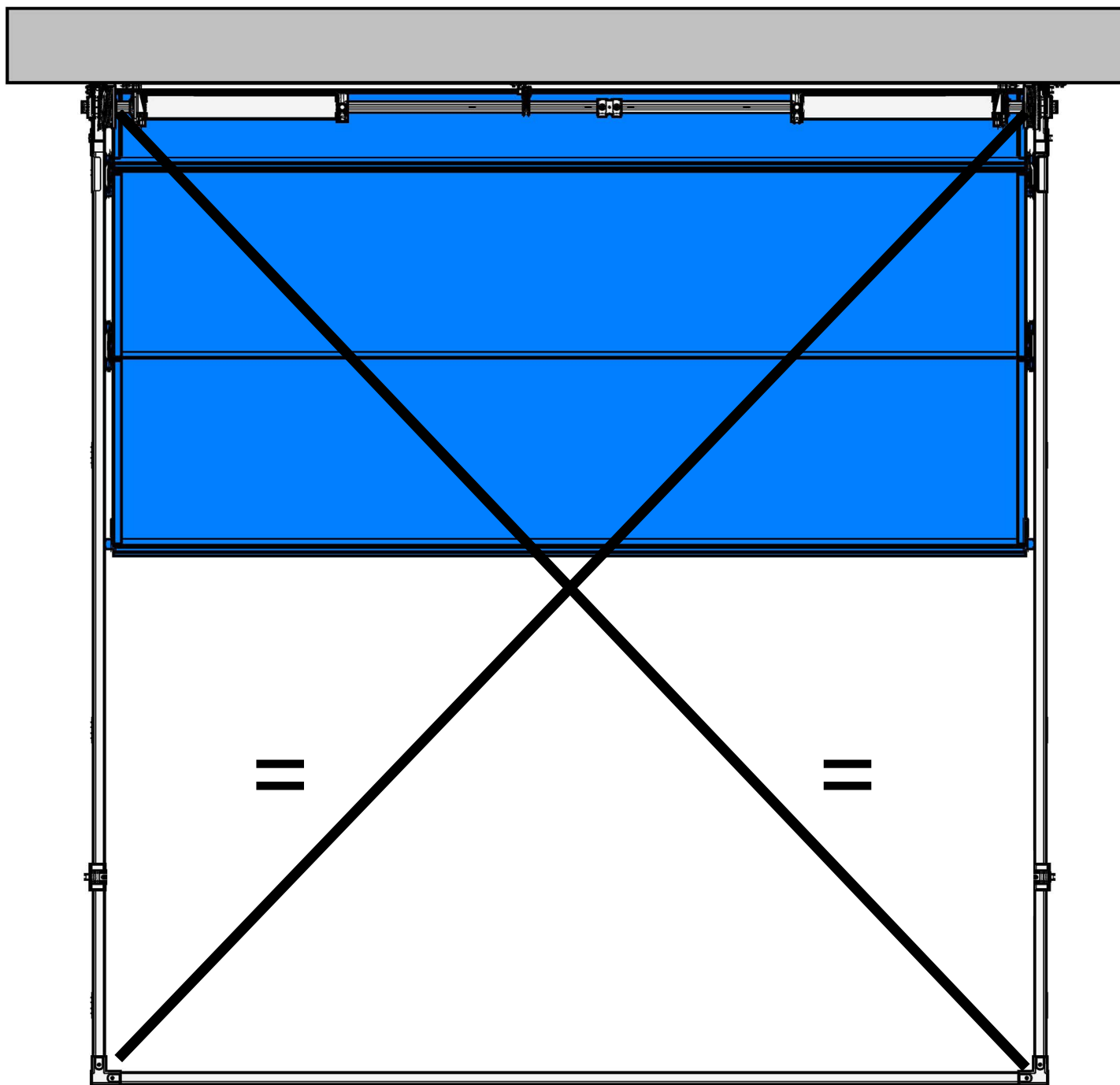
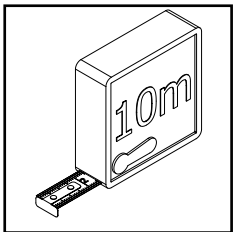

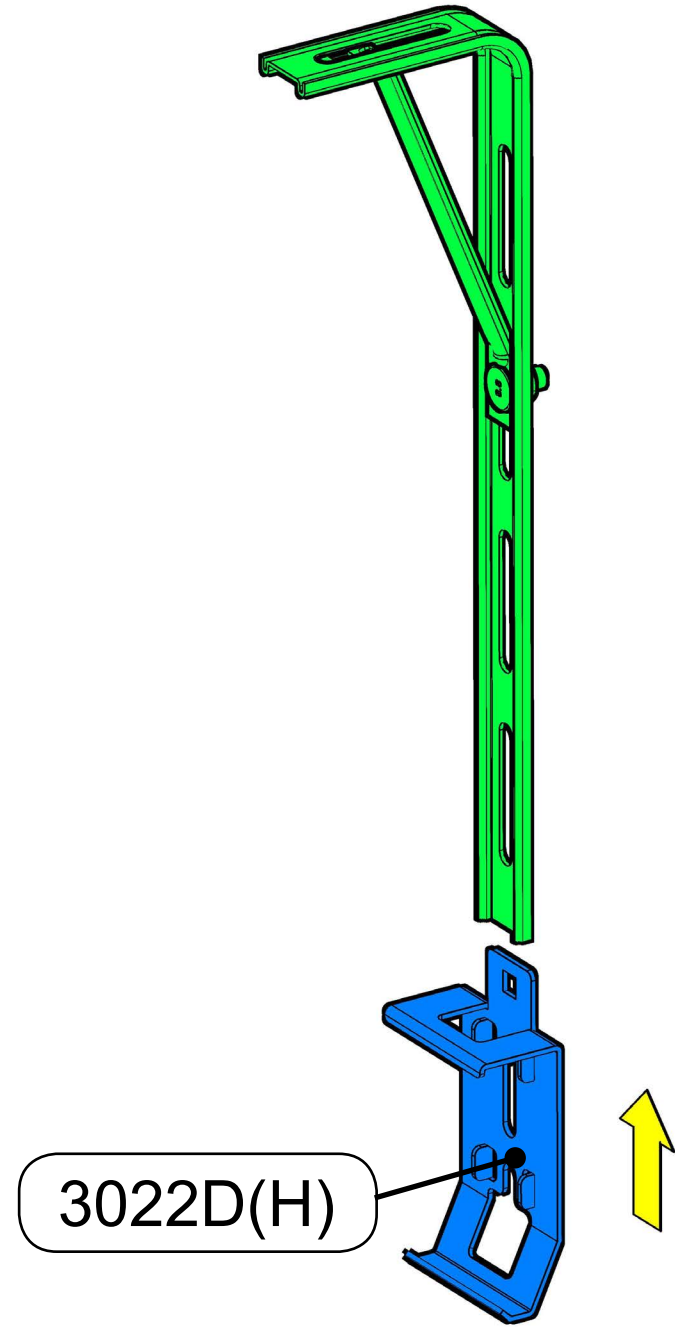
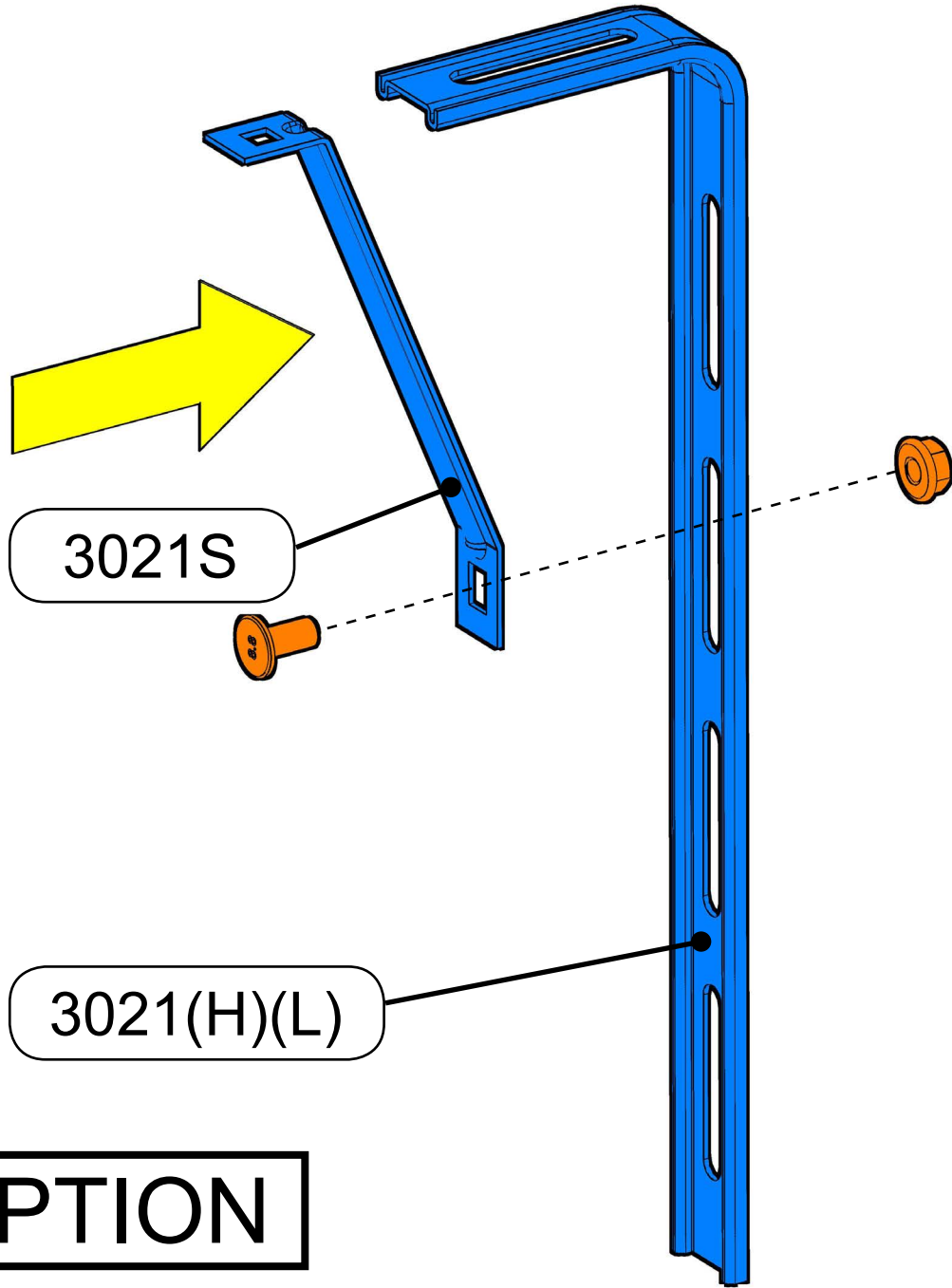
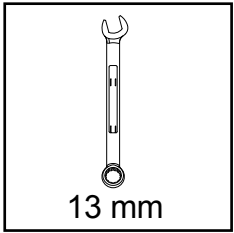
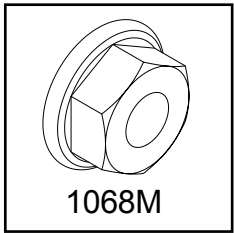
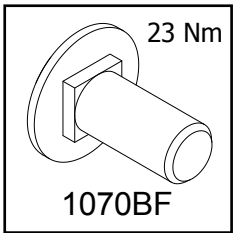

**OPTION**



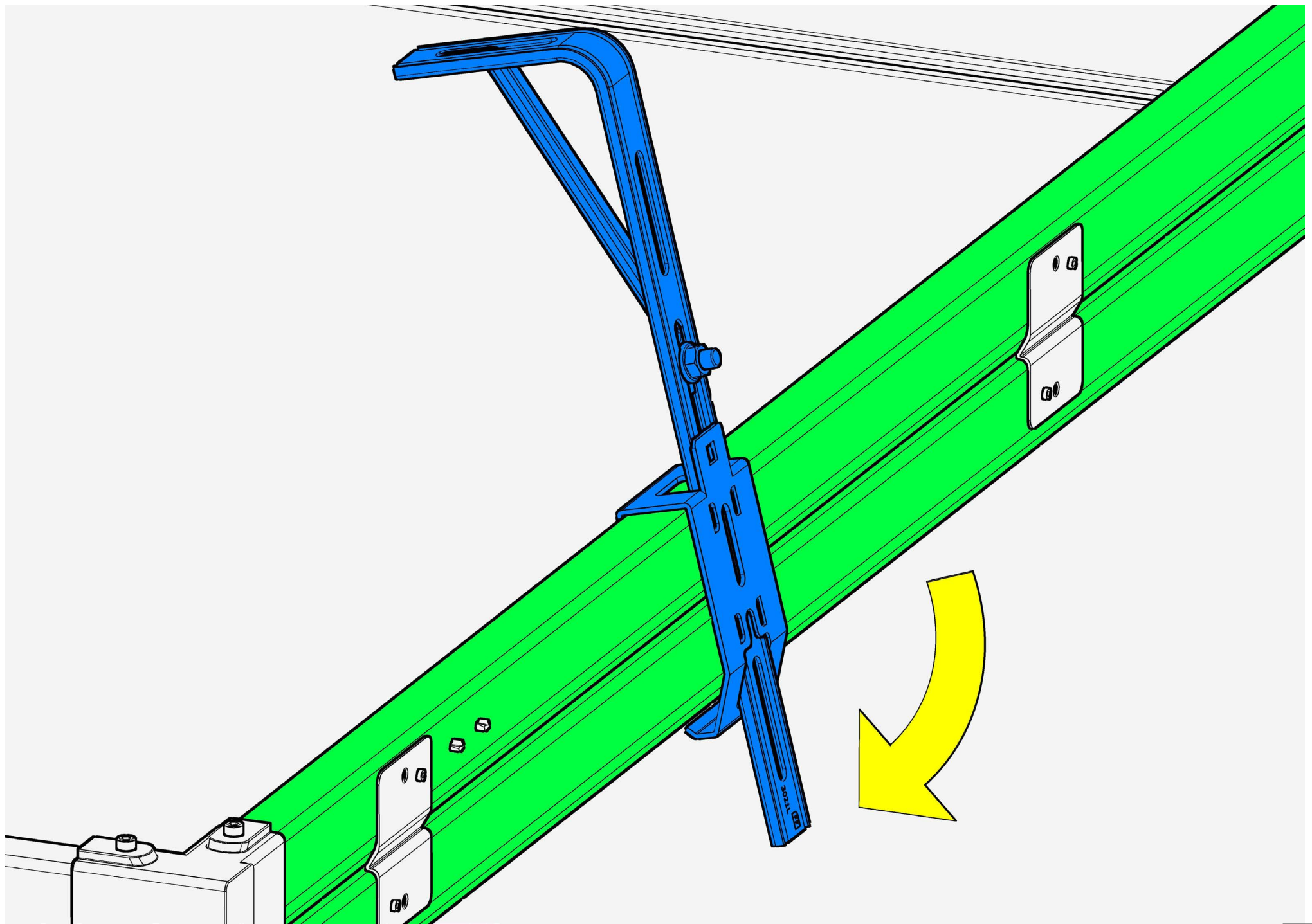

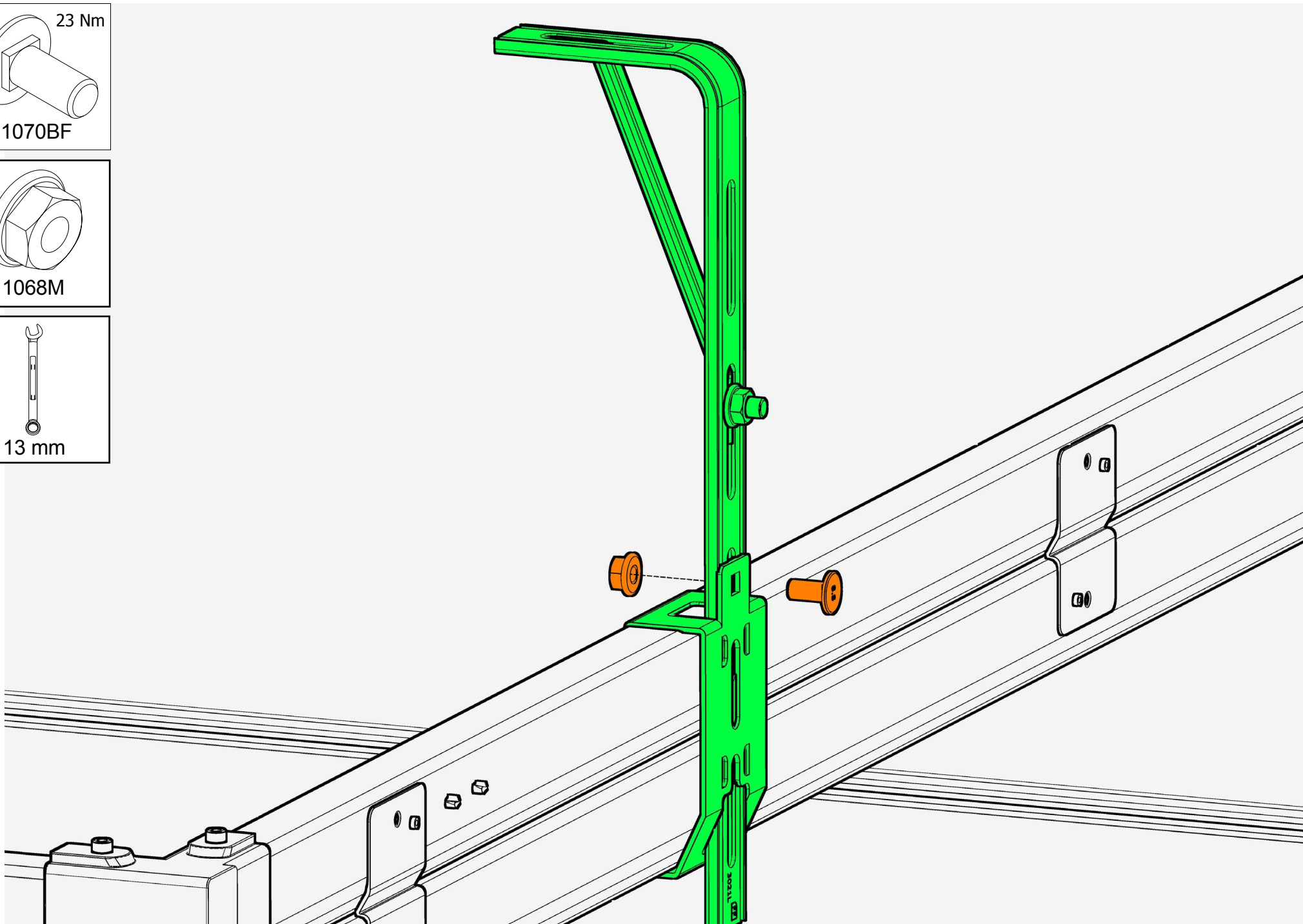
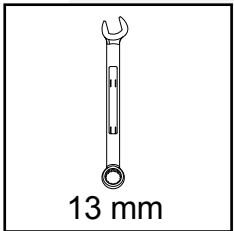
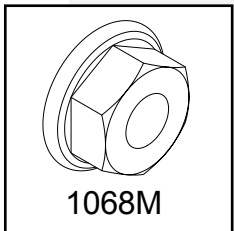
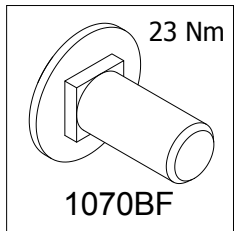

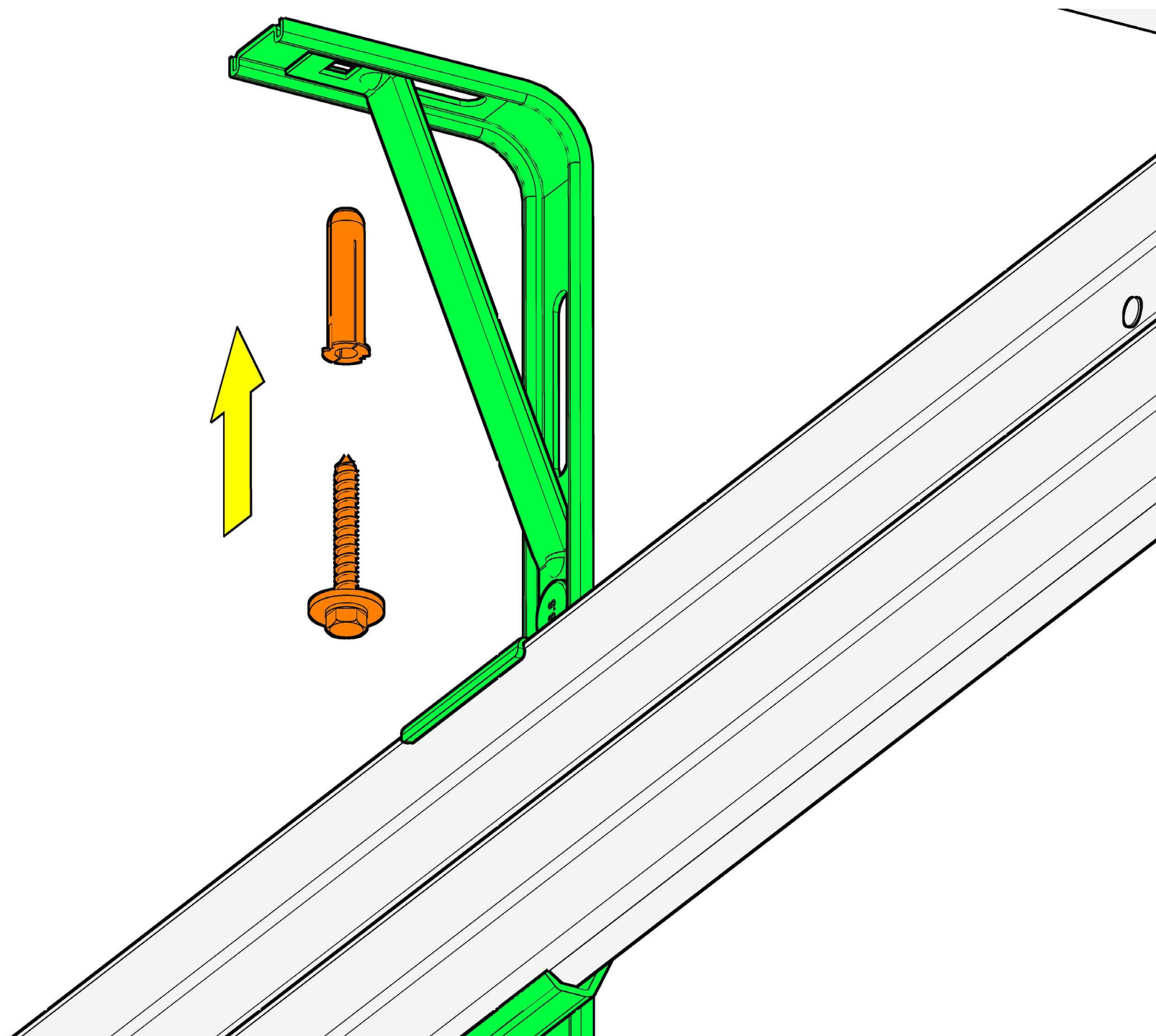
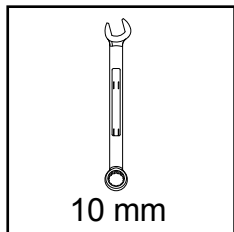
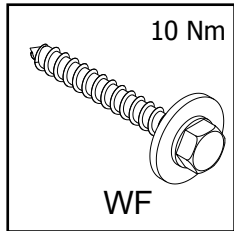
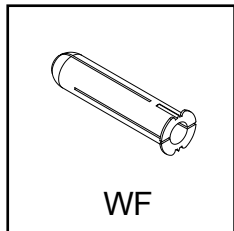
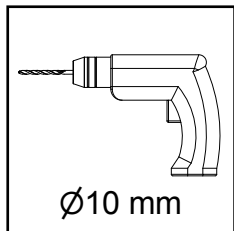

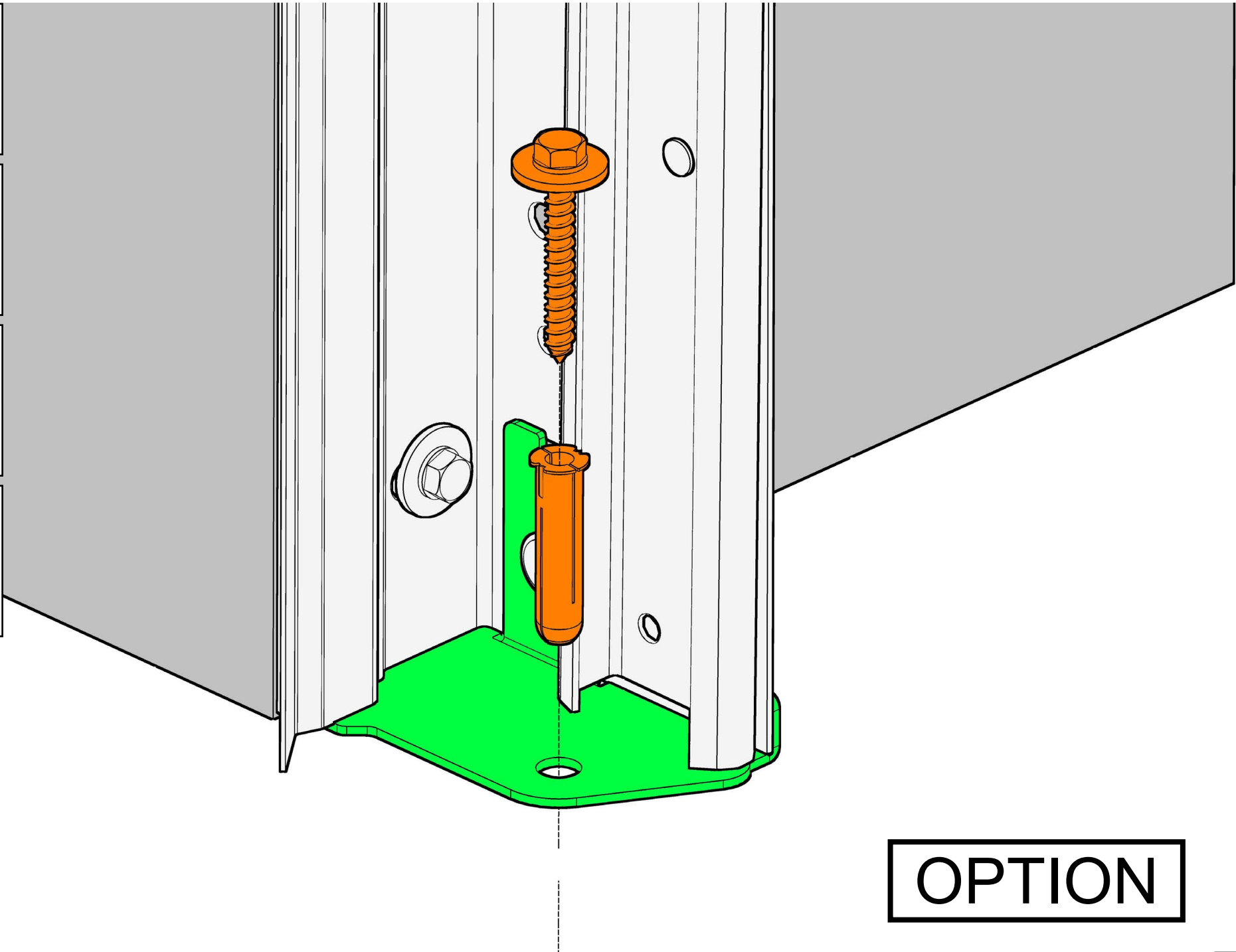
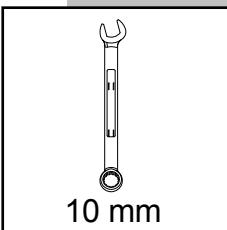
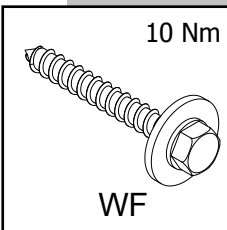
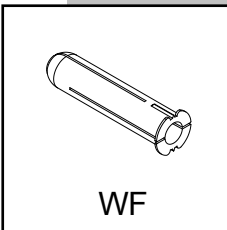
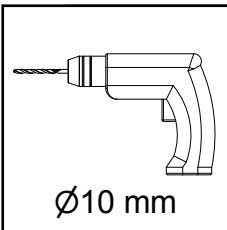

**OPTION**

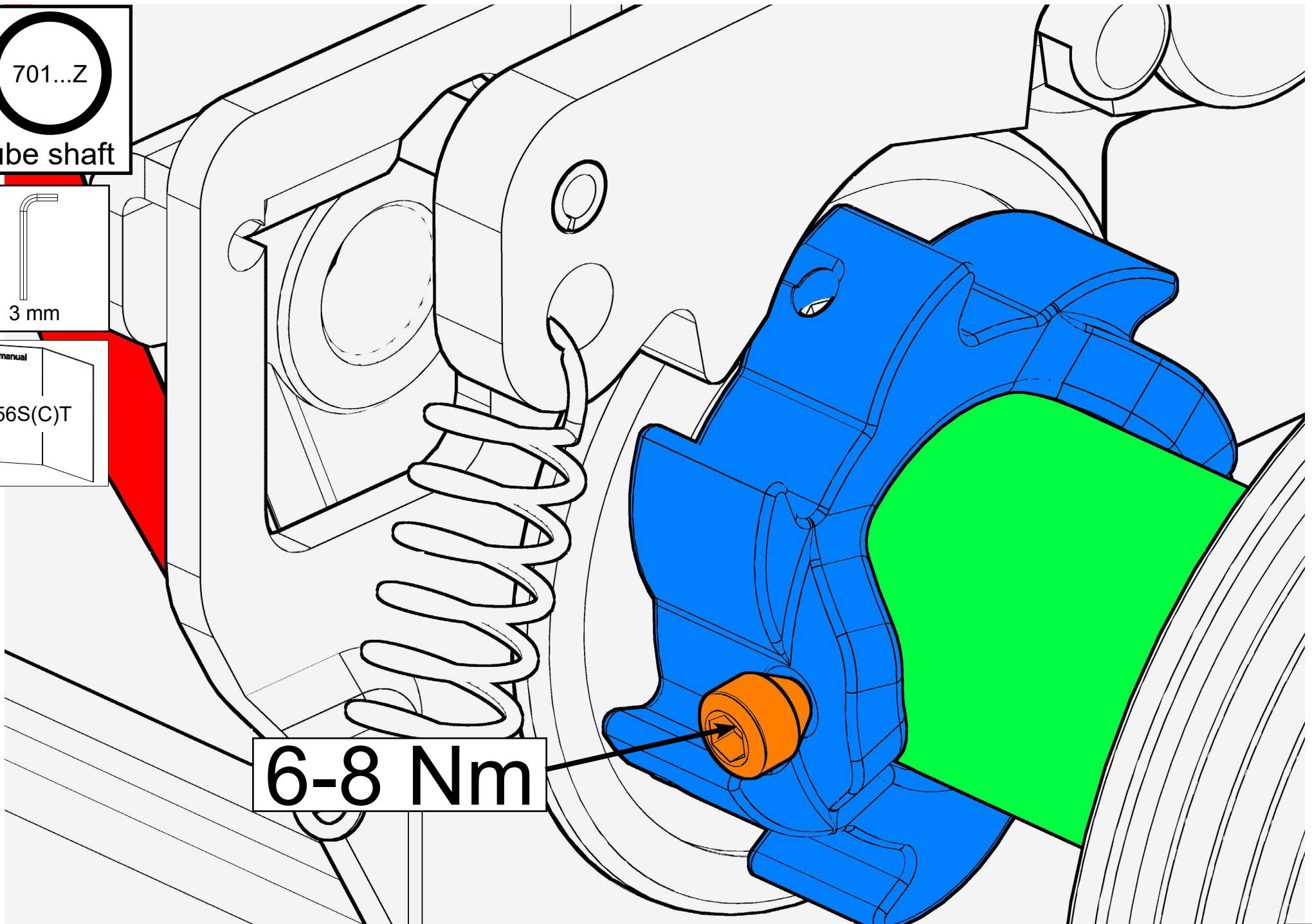
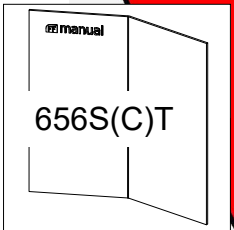
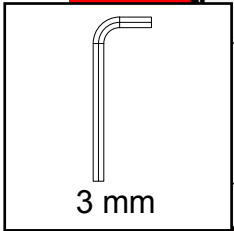
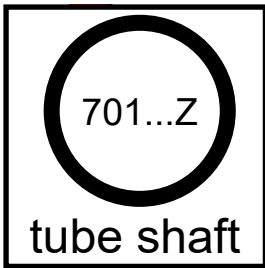

6-8 Nm

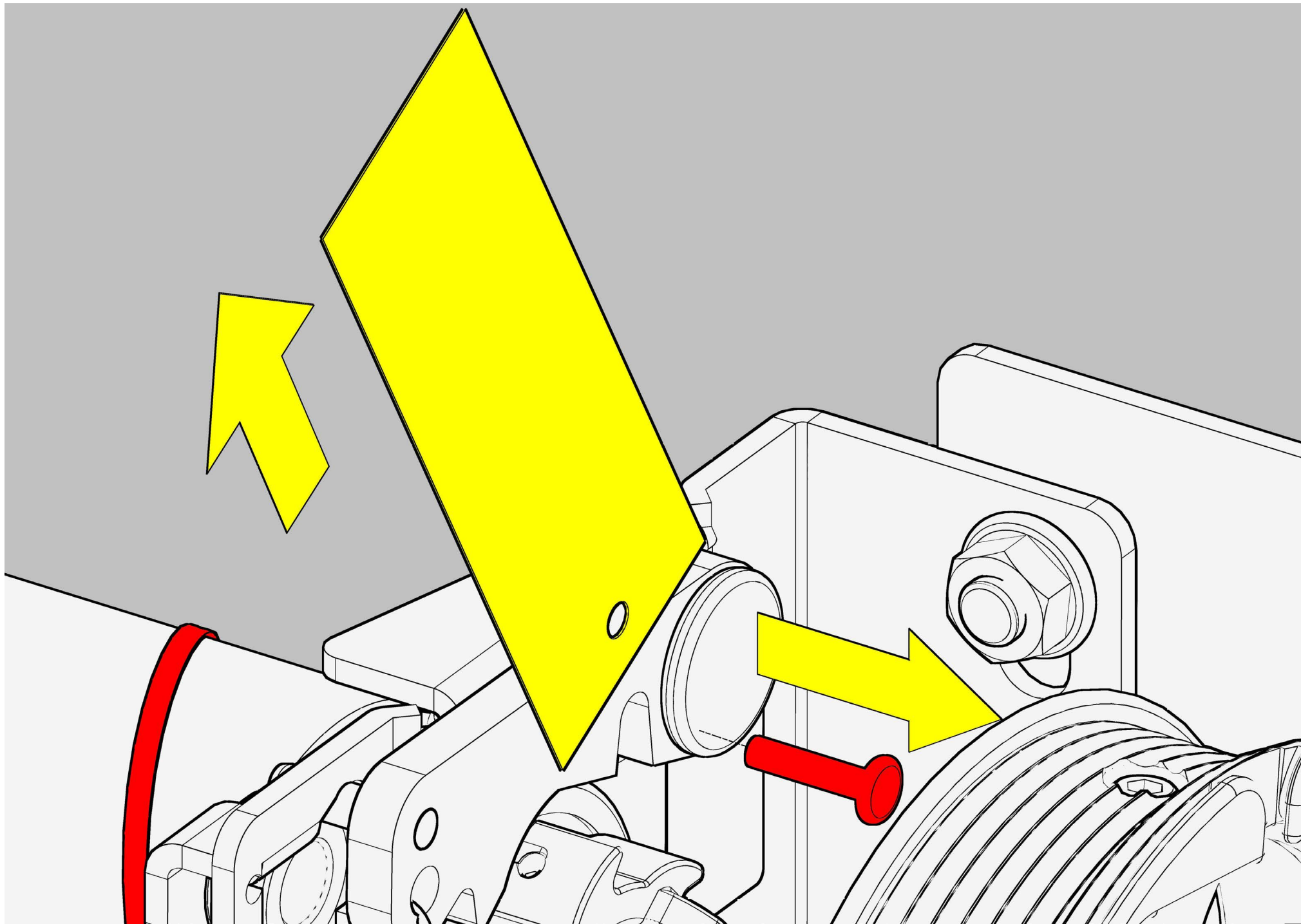

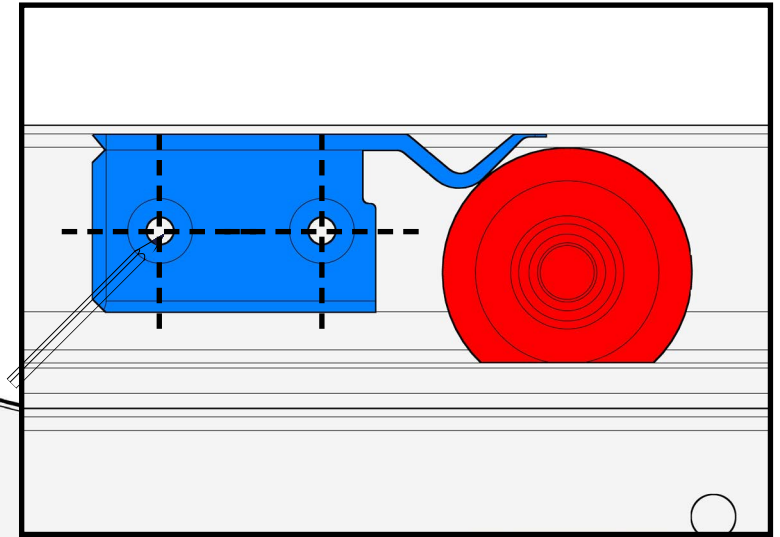
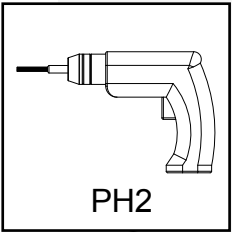
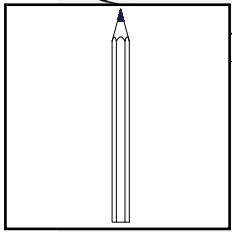
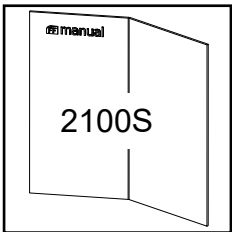

2100S

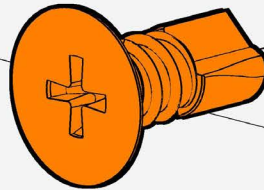
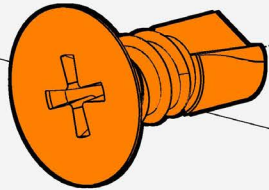

Manuell

~~Motor~~

OPTION

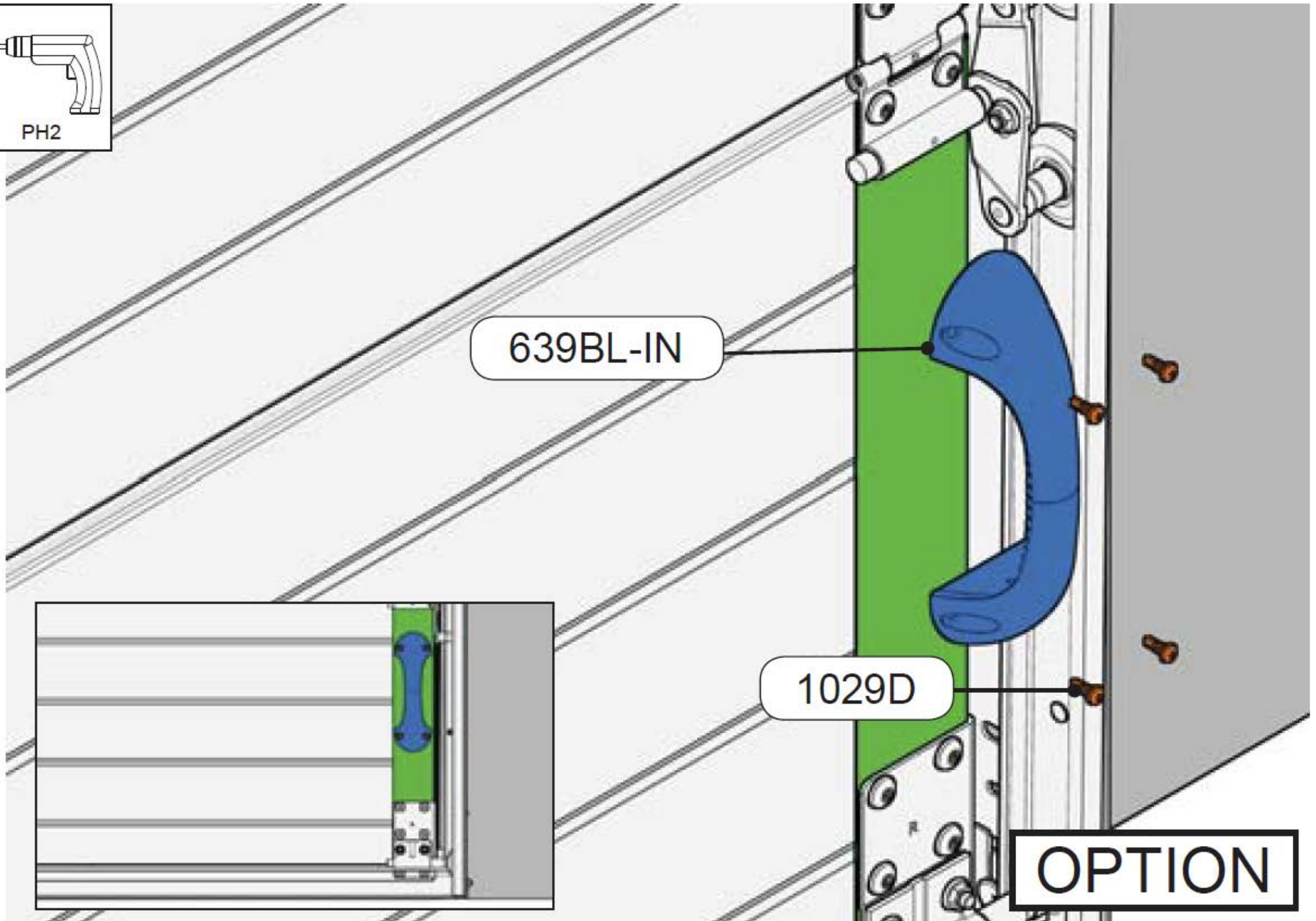
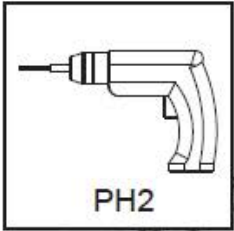



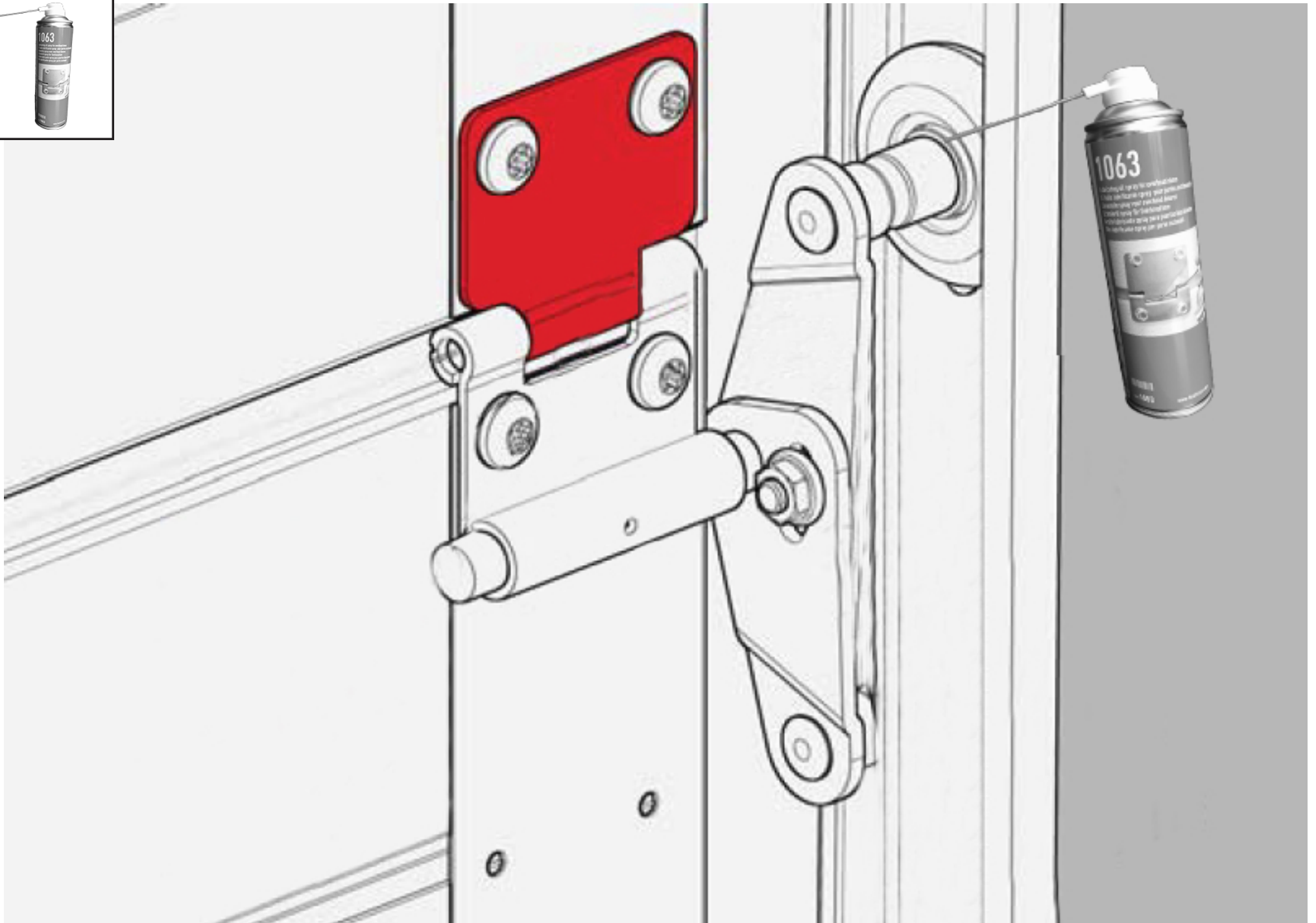

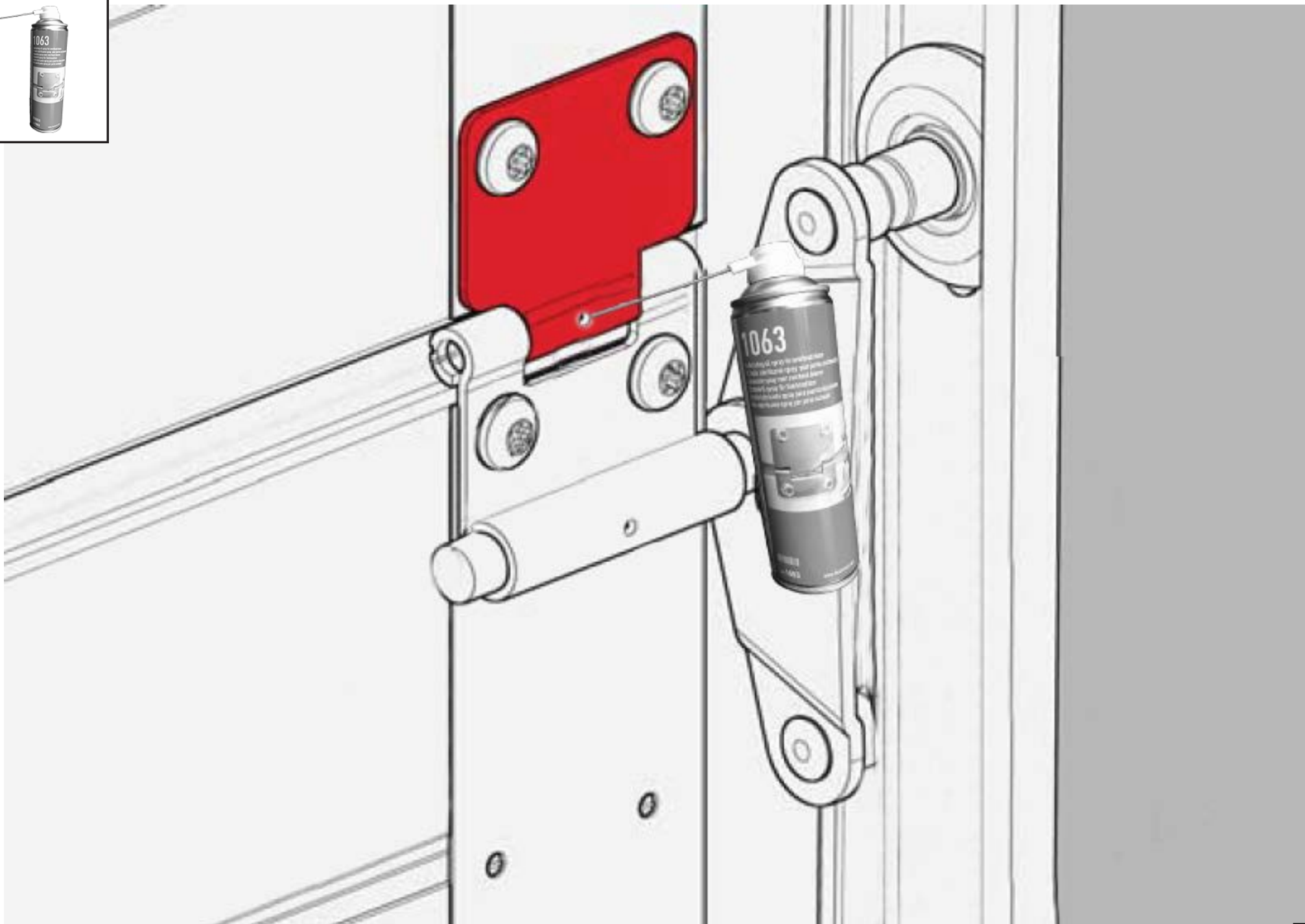

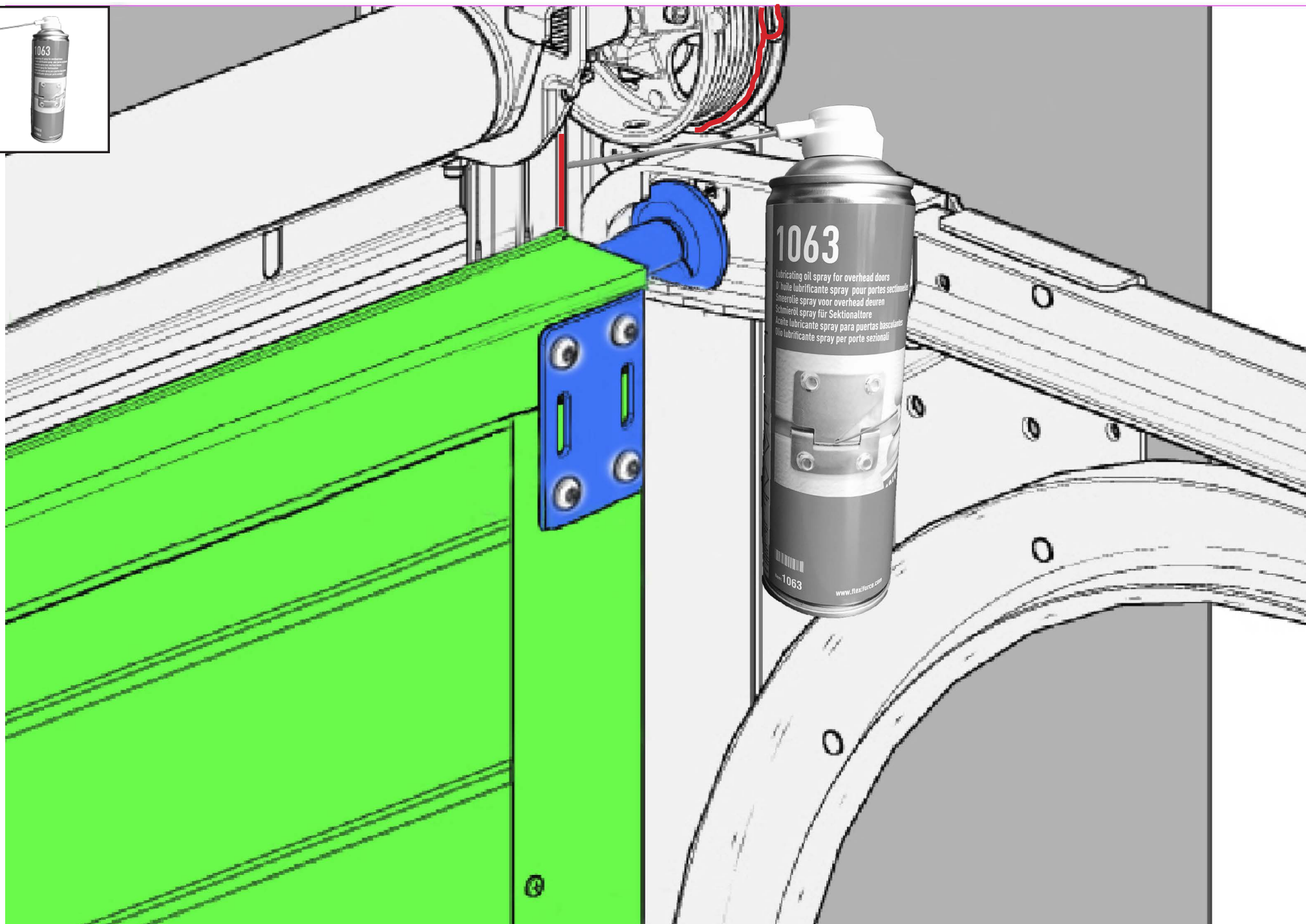

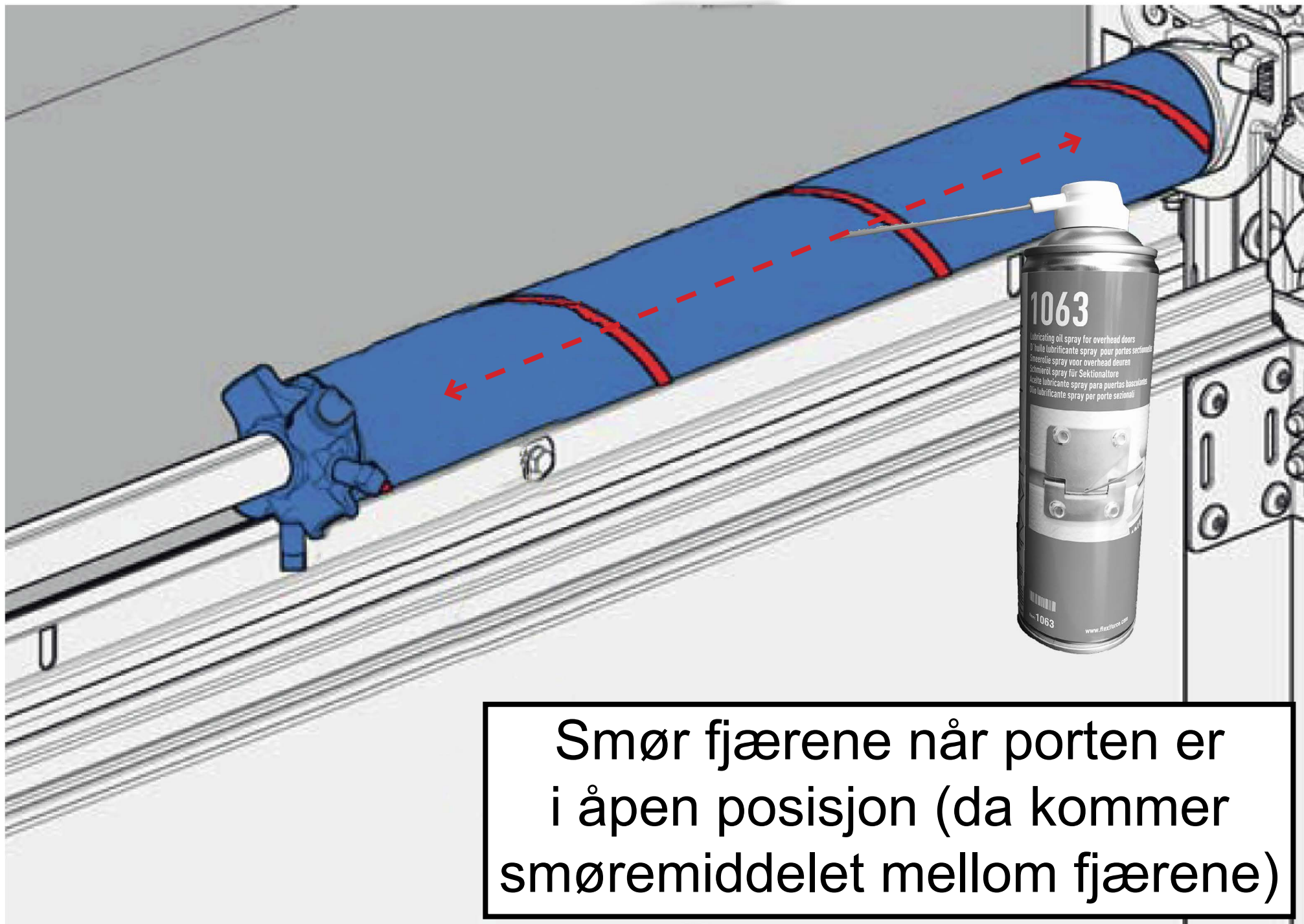

Smør fjærene når porten er i åpen posisjon (da kommer smøremiddelet mellom fjærene)

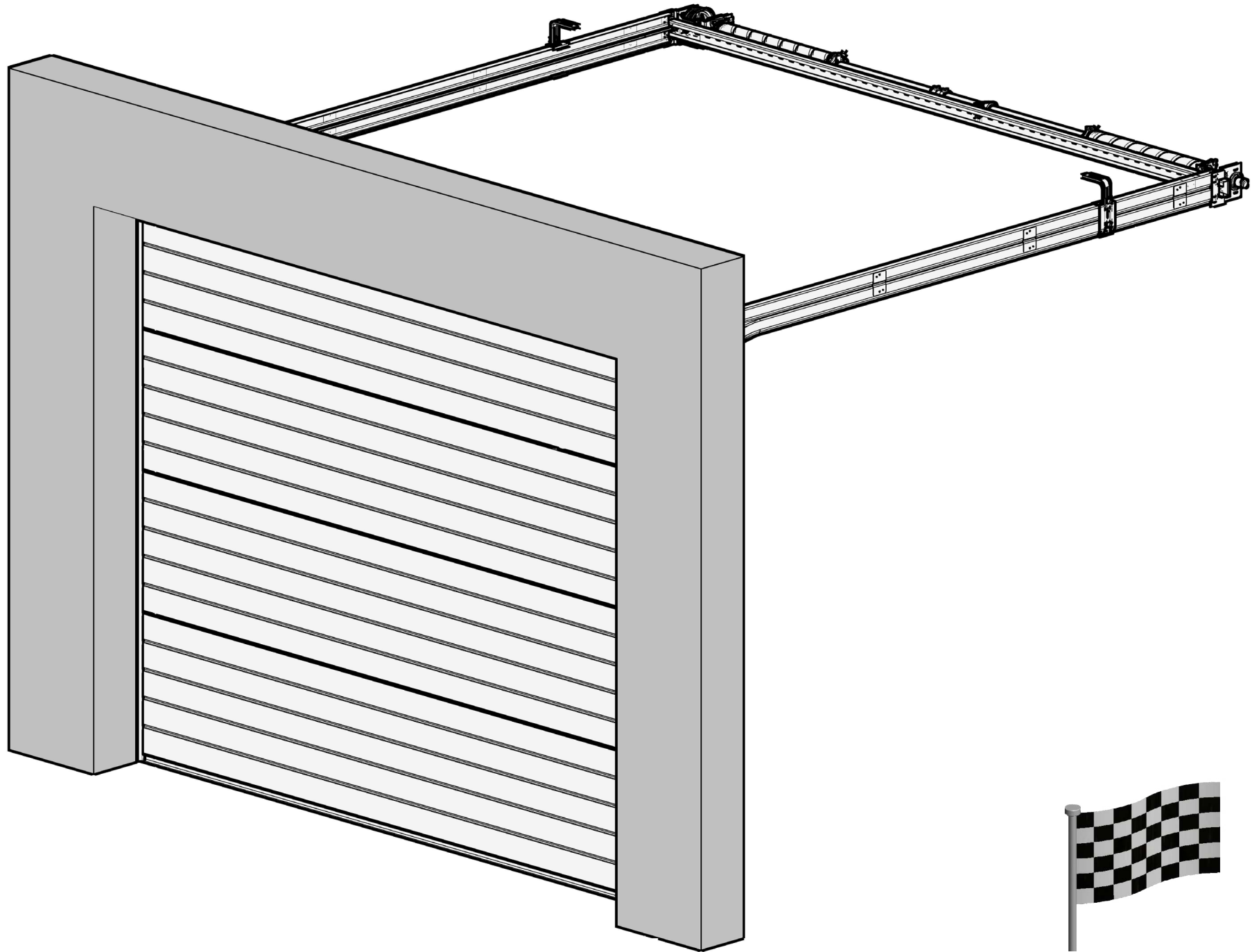

## Antall omdr. Pr. fjær på porter 2250-5000 bredde

<b>Dørhøyde</b>	<b>Antall Omdreininger</b>
2000	9,7 liten trommel FFNL10
2125	10,3 liten trommel FFNL10
2250	10,9 liten trommel FFNL10
2375	11 liten trommel FFNL10
2500	11,6 liten trommel FFNL10
2625	8,9 stor trommel FF-4-13
2750	9,4 stor trommel FF-4-13
2875	9,6 stor trommel FF-4-13
3000	10 stor trommel FF-4-13

## Antall omdr. Pr. fjær på porter 5500 bredde

<b>Dørhøyde</b>	<b>Antall Omdreininger</b>
2000	9,7 liten trommel FFNL10
2125	10,3 liten trommel FFNL10
2250	10,9 liten trommel FFNL10
2375	11 liten trommel FFNL10
2500	8,6 stor trommel FF-4-13
2625	8,9 stor trommel FF-4-13
2750	9,4 stor trommel FF-4-13
2875	9,6 stor trommel FF-4-13
3000	10 stor trommel FF-4-13