



YDEEVNEDEKLARATION



DoP: 0118

til fischer Power-Fast II Skruer (Skruer til brug i tømmerkonstruktioner) – DA

1. Varetypens unikke identifikationskode: **DoP: 0118**
2. Tilsigtet anvendelse: **Til anvendelse i bærende trækonstruktioner eller til fastgørelse af isoleringsmateriale på lægter**
3. Fabrikant: **fischerwerke GmbH & Co. KG, Klaus-Fischer-Straße 1, 72178 Waldachtal, Tyskland**
4. Bemyndiget repræsentant: --
5. System eller systemer til vurdering og kontrol af konstansen af ydeevnen: **3**
6. Europæisk vurderingsdokument: **EAD 130118-01-0603**
Europæisk teknisk vurdering: **ETA-19/0175; 2020-01-07**
Teknisk vurderingsorgan: **ETA-Danmark A/S**
7. Deklareret ydeevne/deklarerede ydeevner:

Mekanisk styrke og stabilitet (BWR 1), Sikkerhed og tilgængelighed ved anvendelse (BWR 4)

- Dimensioner: Se appendiks, særligt Appendiks 12, 13, 14
- Karakteristisk flydemoment: Se appendiks, særligt Appendiks 5
- Bøjningsvinkel: Se appendiks, særligt Appendiks 1
- Karakteristisk træklast: Se appendiks, særligt Appendiks 5, 6, 7
- Karakteristisk hoved træklast af skruer: Se appendiks, særligt Appendiks 7
- Karakteristisk trækstyrke: Se appendiks, særligt Appendiks 3
- Karakteristisk flydespænding: Se appendiks, særligt Appendiks 5
- Karakteristisk vridningsstyrke: Se appendiks, særligt Appendiks 3
- Indsættelsesmoment: Se appendiks, særligt Appendiks 3
- Indbyrdes-, slut-, og kantafstande til skruer eller gevindstænger og minimumstykkelser på træmaterialet.: Se appendiks, særligt Appendiks 8, 9, 22
- Forskydningsmodul / Glidemodul til aksialbelastede skruer og gevindstænger. : Se appendiks, særligt Appendiks 8
- Modstandsdygtig overfor korrosion: Se appendiks, særligt Appendiks 1, 10, 12, 13, 14

Brandbeskyttelse (BWR 2)

- Brandegenskaber: Skruerne opfylder kravene til klasse A 1

8. Relevant teknisk dokumentation og/eller specifik teknisk dokumentation: ---

Ydeevnen til den vare, der er anført ovenfor, er i overensstemmelse med den deklarerede ydeevne. Denne ydeevnedeklaration er udarbejdet i overensstemmelse med forordning (EU) nr. 305/2011 på eneansvar af den fabrikant, der er anført ovenfor.

Underskrevet til fabrikanten og på dennes vegne af:

Thilo Pregartner, Dr.-Ing.

Wolfgang Hengesbach, Dipl.-Ing., Dipl.-Wirtsch.-Ing.

Tumlingen, 2020-02-17

- Denne DoP er tilgængelig i forskellige sprogversioner. I tilfælde af forskellige fortolkninger gælder den engelske version..
- Appendikset indeholder frivillige og udvidede informationer på engelsk. De overgår de lokale (sprogneutrale) retslige krav.

II SPECIFIC PART OF THE EUROPEAN TECHNICAL ASSESSMENT

1 Technical description of product and intended use

Technical description of the product

“fischer Power-Fast II” screws are self-tapping screws to be used in timber structures. They shall be threaded over a part of the length or over the whole length. The screws shall be produced from carbon steel wire for nominal diameters between 3,0 mm and 6,0 mm. Where corrosion protection is required, the material or coating shall be declared in accordance with the relevant specification given in Annex A of EN 14592.

Geometry and Material

The nominal diameter d (outer thread diameter) of the screws shall not be less than 3,0 mm and shall not be greater than 6,0 mm.

The overall length l_s of the screws, shall not be less than 20 mm and shall not be greater than 300 mm. Dimensions see Annex A.

The ratio of inner thread diameter to outer thread diameter d_i/d ranges from 0,50 to 0,80.

The screws are threaded over a minimum length l_g of $4,0 \cdot d$ (i.e. $l_g \geq 4,0 \cdot d$).

The thread pitch p (distance between two adjacent thread flanks) ranges from $0,50 \cdot d$ to $0,85 \cdot d$.

No breaking shall be observed at a bend angle of $\alpha \leq (45/d^{0,7} + 20)^\circ$.

2 Specification of the intended use in accordance with the applicable EAD

The screws are used for connections in load bearing timber structures between members, softwood and hardwood of: Solid timber, glued laminated timber, cross-laminated timber (CLT) and laminated veneer lumber, similar glued members, wood-based panels or steel. “fischer Power-Fast II” screws with a thread over the full length can also be used as tensile or compressive reinforcement perpendicular to the grain or as shear reinforcement. Furthermore “fischer Power-Fast II” screws with diameter of 6 mm may also be used for fixing of thermal insulation on rafters and on vertical facades. Steel plates and wood-based panels except solid wood panels and EGGER Eurostrand OSB 4 TOP, laminated veneer lumber and CLT, shall only be fixed on the side of the screw head.

The following wood-based panels may be used:

- Plywood according to EN 636 or European Technical Assessment or national provisions that apply at the installation site
- Particleboard according to EN 312 or European Technical Assessment or national provisions that apply at the installation site
- Oriented Strand Board according to EN 300 or European Technical Assessment or national provisions that apply at the installation site
- Fibreboard according to EN 622-2 and 622-3 or European Technical Assessment (minimum density 650 kg/m^3) or national provisions that apply at the installation site
- Cement bonded particleboard according to EN 634 or European Technical Assessment or national provisions that apply at the installation site
- Solid wood panels according to EN 13353 or European Technical Assessment or national provisions that apply at the installation site
- Wood-based panels for use in constructions according to EN 13986
- Cross laminated timber according to European Technical Assessment
- Laminated Veneer Lumber according to EN 14374 or European Technical Assessment
- Engineered wood products according to European Technical Assessment, provided that the ETA for the product provides provisions for the use of self-tapping screws and these provisions are applied

The screws shall be driven into softwood and hardwood with a maximum characteristic density of 730 kg/m^3 without pre-drilling or after pre-drilling (see Table 1 and Table 2) with a diameter not larger than the inner thread diameter for the length of the threaded part and with a maximum of the smooth shank diameter for the length of the smooth shank.

Table 1: Recommended pre-drilling diameters

Nominal diameter d [mm]	Bore-hole diameter [mm]	
	Softwood	Hardwood
3,0	2,0	2,5
3,5	2,0	2,5
4,0	2,5	3,0
4,5	2,5	3,0
5,0	3,0	3,0
6,0	4,0	4,0

Recommended values without pre-drilling for the maximum penetration length of the threaded part of “fischer Power-Fast II” made of carbon steel in wood based members like ash, beech and oak or LVL

according to ETA-14/0354 (e.g. Baubuche) are shown in Table 2.

Table 2: Recommended penetration length without pre-drilling in hardwood

Nominal diameter d [mm]	Maximum penetration length [mm]
3,0	40
3,5	45
4,0	50
4,5	60
5,0	70
6,0	70

The hole diameter in steel members must be pre-drilled with a suitable diameter.

In connections with screws with countersunk head according to Annex A the head must be flush with the surface of the connected structural member. A deeper countersunk is not allowed.

Pan head screws according to Annex A may be used together with washers according to EN ISO 7094.

The intended use of the screws is in timber connections for which all requirements of mechanical resistance, stability and safety in use in the sense of the Basic Works Requirements 1 and 4 of Regulation 305/2011 (EU) shall be fulfilled.

“fischer Power-Fast II” screws with $d \geq 4,5 \text{ mm}$ can be driven in with standard screw driver and with impact screw drivers too (e.g. fischer FSS 18V 400 BL or fischer FSS 18V 600). It is also recommended to use, especially in combination with steel plates, torque controlled tools e.g. torque wrenches.

The design of the connections shall be based on the characteristic load-carrying capacities of the screws.

The design capacities shall be derived from the characteristic capacities in accordance with Eurocode 5 or an appropriate national code. The screws are intended for use for connections subject to static or quasi-static loading.

The zinc-coated screws are for use in timber structures subject to the moisture content of internal conditions defined by the service classes 1 and 2 regarding to EN 1995-1-1:2014.

The provisions made in this European Technical Assessment are based on an assumed intended working life of the screws of 50 years.

The indications given on the working life cannot be interpreted as a guarantee given by the producer or Assessment Body, but are to be regarded only as a means for choosing the right products in relation to the expected economically reasonable working life of the works.

3 Performance of the product and references to the methods used for its assessment

Characteristic	Assessment of characteristic
3.1 Mechanical resistance and stability^{*)} (BWR1)	
Tensile strength	Characteristic value $f_{tens,k}$: Power-Fast II d= 3,0 mm 3,2 kN d= 3,5 mm 4,1 kN d= 4,0 mm 5,2 kN d= 4,5 mm 6,3 kN d= 5,0 mm 8,9 kN d= 6,0 mm 13,1 kN
Torsional strength	Ratio of the characteristic torsional strength to the mean insertion moment: $f_{tor,k} / R_{tor,mean} \geq 1,5$ Characteristic value $f_{tor,k}$: Power-Fast II d= 3,0 mm 1,5 Nm d= 3,5 mm 2,0 Nm d= 4,0 mm 3,0 Nm d= 4,5 mm 4,2 Nm d= 5,0 mm 6,0 Nm d= 6,0 mm 10,0 Nm
3.2 Safety in case of fire (BWR2)	
Reaction to fire	The screws are made from steel classified as performance class A1 of the characteristic reaction to fire, in accordance with the provisions of Commission Delegated Regulation 2016/364 and EC decision 96/603/EC, amended by EC Decision 2000/605/EC.
3.3 Safety in use (BWR4)	See aspects covered by BWR1
3.4 General aspects related to the performance of the product^{*)}	The screws have been assessed as having satisfactory durability and serviceability when used in timber structures using the timber species described in EN 1995-1-1 and subject to the conditions defined by service classes 1 and 2.
Identification	See Annex A
Typical and special application area	See Annex B

^{*)} See additional information in section 3.5 to 3.7

3.5 Mechanical resistance and stability

The load-carrying capacities for the „fischer Power-Fast II“ screws are applicable to the wood-based materials mentioned in paragraph 1 even though the term “timber” has been used in the following. European Technical Assessments for structural members or wood-based panels must be considered if applicable.

The characteristic lateral load-carrying capacities and the characteristic axial withdrawal capacities of „fischer Power-Fast II“ screws should be used for designs in accordance with Eurocode 5 (EN 1995-1-1) or an appropriate national code.

Reductions in the cross-sectional area caused by „fischer Power-Fast II“ screws shall be taken into account in accordance to the Eurocode 5.

3.5.1 Lateral load-carrying capacity

The characteristic lateral load-carrying capacity of „fischer Power-Fast II“ screws shall be calculated according to EN 1995-1-1. The contribution of the rope effect may be considered. For the calculation of the load-carrying capacity, the following parameters should be taken into account.

3.5.1.1 Embedment strength $f_{h,\alpha,k}$ for the use in Solid timber

The embedment strength for „fischer Power-Fast II“ screws in non-pre-drilled holes arranged at an angle between load and grain direction, $0^\circ \leq \alpha \leq 90^\circ$ can be calculated with the help of equation (1).

$$f_{h,\alpha,k} = \frac{0,065 \cdot \rho_k \cdot d^{-0,3}}{k_{90} \cdot \sin^2 \alpha + \cos^2 \alpha} \quad (1)$$

The embedment strength for „fischer Power-Fast II“ screws in pre-drilled holes arranged at an angle between screw axis and grain direction, $0^\circ \leq \alpha \leq 90^\circ$ can be calculated with the help of equation (2).

$$f_{h,\alpha,k} = \frac{0,065 \cdot \rho_k \cdot (1 - 0,022 \cdot d)}{k_{90} \cdot \sin^2 \alpha + \cos^2 \alpha} \quad (2)$$

Note: Due to the modified equations it is possible to do the total calculation to determine the shear capacity with the nominal diameter d . By doing so also in the EN 1995-1-1:2014 chapter 8.2, in the “Theorie of Johansen” the nominal diameter d should be used. As long as the core diameter d_1 is less than 6 mm the influence of the angle between load and grain direction must normally not be considered. It is also possible to carry out the calculation with the inner diameter of the

thread d_1 and use the equations in clause 8.3.1 in the EN 1995-1-1:2014.

With

$$k_{90} = \begin{cases} 1,35 + 0,015 \cdot d & \text{for softwood} \\ 1,30 + 0,015 \cdot d & \text{for LVL*} \\ 0,90 + 0,015 \cdot d & \text{for hardwood} \end{cases} \quad (3)$$

* made from softwood or hardwood

Where

- α Angle between load and the grain direction [°]
- $f_{h,\alpha,k}$ Characteristic embedment strength [N/mm²]
- ρ_k Characteristic timber gross density [kg/m³]
- d Nominal diameter of the screw [mm];

3.5.1.2 Embedment strength $f_{h,\alpha,k}$ for the use in Cross-Laminated-Timber

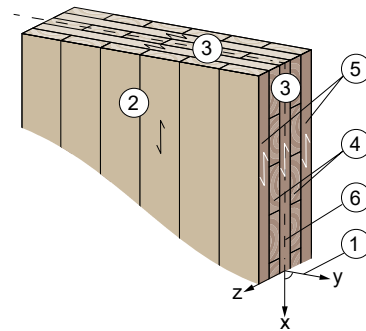

Figure 1: Notations CLT-elements

- (1) Element plane
- (2) Plane surface
- (3) Edge surface (narrow side)
- (4) Inner layer (lamellas)
- (5) Outer layer (lamellas)
- (6) Middle layer (lamella)

If there are no other technical specification (ETA or hEN) for CLT, the embedment strength for screws can be calculated as following. The following specifications are only for screws with a diameter of at least 6 mm, otherwise possible influences of gaps between the single lamellas have to be considered.

Screws in the plane surface

The embedment strength for screws in the plane surface of CLT-elements should be assumed as for solid timber according to equation (1) or (2), based on the characteristic density of the outer layer. If relevant, the angle between force and grain direction of the outer layer should be considered.

Screws in the narrow (edge) side

The embedment strength for screws in the narrow side of CLT-elements should be assumed according to equation (4).

$$f_{h,k} = 20 \cdot d^{-0,5} \quad (4)$$

3.5.1.3 Embedment strength $f_{h,\alpha,k}$ for the use in LVL (ETA-14/0354)

The embedment strength for „fischer Power-Fast II“ screws with $d \geq 5$ mm arranged at an angle between load and grain direction, $0^\circ \leq \alpha \leq 90^\circ$ can be calculated with the help of equation (5) in direction 90|90 (see figure 2).

$$f_{h,\alpha,k} = \frac{f_{h,0,k}}{(0,9 + 0,037 \cdot d) \cdot \sin^2 \alpha + \cos^2 \alpha} \quad (5)$$

With

$$\begin{aligned} d = 5,0 \text{ mm: } & f_{h,0,k} = 50,0 \text{ N/mm}^2 \\ d = 6,0 \text{ mm: } & f_{h,0,k} = 46,0 \text{ N/mm}^2 \end{aligned}$$

3.5.1.4 Effective number of screws per row n_{ef}

For laterally loaded screws, the rules for multiple fastener connections in EN 1995-1-1 should be applied.

3.5.2 Yield strength $f_{y,Rk}$

The characteristic yield strength of the different screw types of „fischer Power-Fast II“ can be taken into account as shown below.

$$f_{y,Rk} = 1050 \text{ N/mm}^2 \quad (6)$$

3.5.3 Yield moment $M_{y,Rk}$

The characteristic yield moment shall be calculated with the help of equation (7)

$$M_{y,Rk} = 0,15 \cdot 600 \cdot d^{2,65} \quad (7)$$

Where

$M_{y,Rk}$	Characteristic yield moment [Nmm]
d	Nominal diameter of the threaded part [mm]

3.5.4 Axial withdrawal capacity

The axial withdrawal capacity is limited by the head pull-through capacity, the withdrawal capacity and the tensile or compressive capacity of the screw.

For „fischer Power-Fast II“ fully threaded screws, the withdrawal capacity of the thread in the member with the head may be taken into account instead of the head pull-through capacity.

3.5.4.1 Withdrawal capacity $F_{ax,\alpha,Rk}$ Solid timber and Glued Laminated, Timber (EN 338, EN 14080) and LVL (ETA-14/0354)

The characteristic withdrawal capacity in softwood of „fischer Power-Fast II“ screws with an angle of $0^\circ \leq \alpha \leq 90^\circ$ shall be calculated according to equation (8). For screws with an outer diameter $d \leq 5,0$ mm equation (8) is only valid for $45^\circ \leq \alpha \leq 90^\circ$.

$$F_{ax,\alpha,Rk} = n_{ef} \cdot k_{ax} \cdot f_{ax,90,k} \cdot d \cdot l_{ef} \cdot \left(\frac{\rho_k}{350} \right)^{0,8} \quad (8)$$

With

$$k_{ax} = \min \left\{ \begin{aligned} & 0,3 + (0,7 \cdot \alpha) / 45^\circ \\ & 1,00 \end{aligned} \right. \quad (9)$$

According to equation (10) the point side penetration length has to be considered between the following range.

$$l_{ef} = \min \left\{ \begin{aligned} & 4 \cdot d \\ & \sin \alpha \\ & 20 \cdot d \end{aligned} \right.$$

(10)

Where

d	Outer thread diameter [mm]
l_{ef}	Penetration length of the threaded part according to EN 1995-1-1; For fully threaded screws the thread length including the head length in [mm]
α	Angle between grain and screw axis [$^\circ$]
ρ_k	Characteristic timber gross density, maximum 730 kg/m^3 [kg/m^3]
$F_{ax,\alpha,Rk}$	Characteristic withdrawal capacity of the screw with an angle α to the grain [N]
n_{ef}	Effective number of screws according to EN 1995-1-1:2014
$f_{ax,90,k}$	Characteristic withdrawal parameter as following.

	Power-Fast II	in solid timber or glued laminated timber
$d= 3,0$ mm	$f_{ax,90,k} =$	15,5 N/mm ²
$d= 3,5$ mm	$f_{ax,90,k} =$	14,9 N/mm ²
$d= 4,0$ mm	$f_{ax,90,k} =$	14,5 N/mm ²
$d= 4,5$ mm	$f_{ax,90,k} =$	14,1 N/mm ²
$d= 5,0$ mm	$f_{ax,90,k} =$	13,8 N/mm ²
$d= 6,0$ mm	$f_{ax,90,k} =$	12,9 N/mm ²

Power-Fast II	in LVL according to ETA-14/0354	
d= 5,0 mm	$f_{ax,90 90,k}$	40,0 N/mm ²
	$f_{ax,90 00,k}$	32,0 N/mm ²
	$f_{ax,00 00,k}$	32,0 N/mm ²
d= 6,0 mm	$f_{ax,90 90,k}$	32,0 N/mm ²
	$f_{ax,90 00,k}$	24,0 N/mm ²
	$f_{ax,00 00,k}$	24,0 N/mm ²

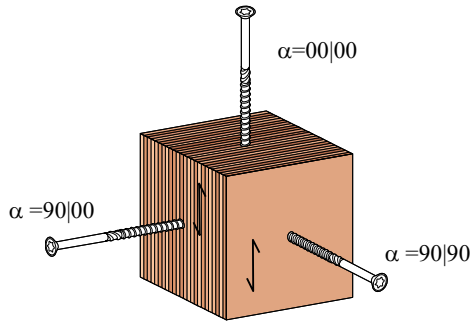

Figure 2: Power-Fast II in hardwood LVL

The characteristic withdrawal capacity in hardwood LVL according to ETA-14/0354 of „fischer Power-Fast II“ screws with an angle of $0^\circ \leq \alpha \leq 90^\circ$ shall be calculated according to equation (8). For screws with an outer diameter $d \leq 5,0$ mm equation (8) is only valid for $45^\circ \leq \alpha \leq 90^\circ$.

$$F_{ax,\alpha,Rk} = n_{ef} \cdot k_{ax} \cdot f_{ax,\alpha|k} \cdot d \cdot l_{ef} \cdot \left(\frac{\rho_k}{730} \right)^{0,8} \quad (11)$$

With

$$k_{ax} = \min \begin{cases} 0,3 + (0,7 \cdot \alpha) / 45^\circ \\ 1,00 \end{cases} \quad (12)$$

3.5.4.2 Withdrawal capacity $F_{ax,Rk}$ EGGER Eurostrand OSB 4 TOP

The characteristic axial withdrawal capacity of „fischer Power-Fast II“ screws in EGGER Eurostrand OSB 4 TOP with an angle of $\alpha = 90^\circ$ and a thickness of at least 12 mm can be calculated according to equation (8), with

$$f_{ax,90,OSB,Rk} = 10 \text{ N/mm}^2 \quad (13)$$

for “fischer Power-Fast II” screws with diameter $d \geq 5$ mm (see Egger Eurostrand OSB 4 TOP).

3.5.4.3 Withdrawal capacity $F_{ax,Rk}$ Cross laminated timber

If there are no other technical specification (ETA or hEN) for cross laminated timber (CLT), the withdrawal capacity for screws can be calculated as following.

Screws in the plane surface

The withdrawal capacity for screws with $d \geq 6$ mm in the plane surface of CLT-elements should be assumed as for solid timber according to equation (8) based on a characteristic density of equation (14), if there are no other specifications are given. If necessary gaps between the single lamellas have to be considered.

$$\rho_k = 1,1 \cdot \rho_{lay,k} \quad (14)$$

With

$\rho_{lay,k}$ Lowest characteristic density of the lamella in the CLT-element [kg/m³]

Screws in the narrow side

The withdrawal capacity for screws in the narrow side of CLT-elements should be assumed according to equation (15).

$$F_{ax,Rk} = 20 \cdot d^{0,8} \cdot l_{ef}^{0,9} \quad (15)$$

Screws in the narrow side should be driven perpendicular into the grain of the lamella. The penetration length has to be at least $3 \cdot d + l_{ef}$.

If it is guaranteed that the angle between the lamellas and the screw axis is $\geq 30^\circ$ the characteristic withdrawal capacity from equation (15) can be increased of about 25 %.

For screws penetrating more than one layer of cross laminated timber, the different layers may be taken into account proportionally.

3.5.4.4 Effective number of screws n_{ef}

For axially loaded screws in tension, where the external force is parallel to the screw axis, the rules in EN 1995-1-1, 8.7.2 (8) should be applied.

$$n_{ef} = n^{0,9} \quad (16)$$

For inclined screws in timber-to-timber or steel-to-timber shear connections, where the screws are arranged under an angle $30^\circ \leq \alpha \leq 60^\circ$ between the shear plane and the screw axis, the effective number of screws n_{ef} should be determined with equation below.

$$n_{ef} = \max \begin{cases} n^{0,9} \\ 0,9 \cdot n \end{cases} \quad (17)$$

With

n Pieces of (inclined/cross pairs) screws in a row parallel to the grain

For screws as compression reinforcement or inclined screws as fasteners in mechanically jointed beams or columns $n_{ef} = n$.

3.5.5 Head pull-through capacity $f_{head,k}$ Solid timber and Glued Laminated Timber (EN 338, EN 14080) and LVL (ETA-14/0354)

The characteristic head pull-through capacity of „fischer Power-Fast II“ screws in solid timber can be calculate as following.

$$F_{ax,\alpha,Rk} = n_{ef} \cdot f_{head,k} \cdot d_h^2 \cdot \left(\frac{\rho_k}{350} \right)^{0,8} \quad (18)$$

For timber elements with a thickness of at least 20 mm, the characteristic value of the head pull-through parameter $f_{head,k}$ can be taken into account as following.

Power-Fast II	in solid timber, cross laminated timber, glued laminated timber and LVL	
d= 3,0 mm	d _h = 6,0 mm	$f_{head,k}=19,0 \text{ N/mm}^2$
d= 3,5 mm	d _h = 7,0 mm	$f_{head,k}=16,3 \text{ N/mm}^2$
d= 4,0 mm	d _h = 8,0 mm	$f_{head,k}=15,0 \text{ N/mm}^2$
d= 4,5 mm	d _h = 8,8 mm	$f_{head,k}=14,2 \text{ N/mm}^2$
d= 5,0 mm	d _h = 9,8 mm	$f_{head,k}=13,4 \text{ N/mm}^2$
d= 6,0 mm	d _h =11,8mm	$f_{head,k}=13,0 \text{ N/mm}^2$

3.5.6 Head pull-through capacity $f_{head,k}$ Wood based panels

For the following wood-based panels described in chapter 1 with a thickness of more than 20 mm the head pull-through parameter can constitute with

$$f_{head,k} = 10 \text{ N/mm}^2 \quad (19)$$

For wood-based panels with a thickness between 12 mm and 20 mm the characteristic value of the head pull-through parameter can calculate with

$$f_{head,k} = 8 \text{ N/mm}^2 \quad (20)$$

For wood based panels with a thickness of less than 12 mm the characteristic head pull-through capacity shall be calculated with $f_{head,k}=8 \text{ N/mm}^2$ with a limit of 400 N complying with a minimum thickness of the wood

based panels of $1,2 \cdot d$. In addition, to apply the minimum thickness of Table 3.

Table 3: Minimum thickness of wood based panels

Wood based panel	Min. thickness [mm]
Plywood	6
Oriented Strand board OSB	8
Solid wood panels	12
Particleboards	8
Cement bonded particle boards	8
Fibreboards (hardboards and medium boards)	6

3.5.7 Tensile capacity $f_{tens,k}$

The characteristic tensile capacity $f_{tens,k}$ of „fischer Power-Fast II“ screws depending on the outer diameter is for

Power-Fast II		
d= 3,0 mm	$f_{tens,k} =$	3,2 kN
d= 3,5 mm	$f_{tens,k} =$	4,1 kN
d= 4,0 mm	$f_{tens,k} =$	5,2 kN
d= 4,5 mm	$f_{tens,k} =$	6,3 kN
d= 5,0 mm	$f_{tens,k} =$	8,9 kN
d= 6,0 mm	$f_{tens,k} =$	13,1 kN

The tear-off capacity of the screw head is greater than the tensile capacity of the screw.

3.5.8 Compression capacity

The design compressive capacity $F_{ax,Rd}$ of „fischer Power-Fast II“ screws with full thread along the length embedded in timber shall be calculated as following.

$$F_{ax,Rd} = \min \begin{cases} F_{ax,Rd} \\ F_{ki,Rd} \end{cases} \quad (21)$$

Where

$F_{ax,Rd}$ According to equation (8)
 $F_{ki,Rd}$ According to equation (22)

$$F_{ki,Rd} = \kappa_c \cdot N_{pl,d} \quad (22)$$

With

$$\kappa_c = 1 \quad \text{for } \bar{\lambda}_k \leq 0,2$$

$$\kappa_c = \frac{1}{k + \sqrt{k^2 - \bar{\lambda}^2}} \quad \text{for } \bar{\lambda}_k > 0,2 \quad (23)$$

and

$$k = 0,5 \cdot \left[1 + 0,49 \cdot (\bar{\lambda}_k - 0,2) + \bar{\lambda}_k^2 \right] \quad (24)$$

The relative slenderness ratio shall be calculated with

$$\bar{\lambda}_k = \sqrt{\frac{N_{pl,k}}{N_{ki,k}}} \quad (25)$$

With the characteristic value for the axial capacity in case of plastic analysis referred to the outer thread diameter

$$N_{pl,k} = \frac{(0,7 \cdot d)^2 \cdot \pi}{4} \cdot f_{y,Rk} \quad (26)$$

And the characteristic ideal elastic buckling load

$$N_{ki,k} = \sqrt{c_h \cdot E_s \cdot I_s} \quad (27)$$

With the

Elastic foundation of the screw:

$$c_h = (0,19 + 0,0084 \cdot d) \cdot \rho_k \cdot \left(\frac{\alpha}{180^\circ} + 0,5 \right) \quad (28)$$

Modulus of elasticity:

$$E_s = 210.000 \text{ N/mm}^2 \quad (29)$$

Second moment of area:

$$I_s = \frac{\pi \cdot (0,7 \cdot d)^4}{64} \quad (30)$$

Note: The compressive capacity must be modified for $f_{ax,d}$ with the factors k_{mod} and γ_M for timber according to EN 1995-1-1 while $N_{pl,d}$ the partial-factor $\gamma_{M,1}$ for steel buckling according to EN 1993-1-1 and/or national standards respectively have to be considered.

3.5.9 Combined laterally and axially loaded screws

For connections subjected to a combination of axial and lateral load, the following expression has to be considered according to equation

$$\left(\frac{F_{ax,Ed}}{F_{ax,Rd}} \right)^2 + \left(\frac{F_{v,Ed}}{F_{v,Rd}} \right)^2 \leq 1 \quad (31)$$

With

$F_{ax,Ed}$ Axial design action [N]

$F_{v,Ed}$ Lateral design action [N]

$F_{ax,Rd}$ Design load-carrying capacity of an axially loaded screw [N]

$F_{v,Rd}$ Design load-carrying capacity of a laterally loaded screw [N]

3.5.10 Slip modulus

Laterally loaded screws

For laterally loaded „fischer Power-Fast II“ screws the slip modulus predrilled or non-predrilled for the serviceability limit state (SLS) for screws could be calculated according to EN 1995-1-1:2014 independent of the angle α to the grain with equation (32).

$$K_{ser} = k_{sys} \cdot k_{sb} \cdot \frac{\rho_m^{1,5} \cdot d}{23} \quad (32)$$

With

$$k_{sys} = \begin{cases} 1 & \text{for timber-timber connections} \\ 2 & \text{for steel-timber connections} \end{cases}$$

k_{sb} Number of shear bands

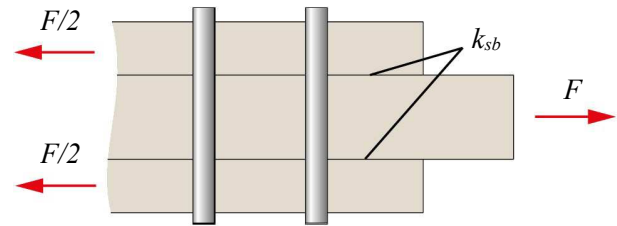

Figure 3: Definition shear bands

Where

K_{ser} Slip modulus in SLS [N/mm]

ρ_m Mean timber density [kg/m³]

Axially loaded screws

For axially loaded screws the slip modulus for the serviceability limit state (SLS) could be calculated independent of the angle α to the grain according to equation (33).

$$K_{ser} = 25 \cdot d \cdot l_{ef} \quad (33)$$

To consider the slip modulus K_u in the ultimate limit state (ULS) K_{ser} has to be reduced for both directions (laterally and axially) according to EN 1995-1-1.

$$K_u = 2/3 \cdot K_{ser} \quad (34)$$

3.5.12 Minimum timber cross section, end- and edge distances

For structural timber members, minimum spacing and distances for screws in predrilled holes are given in EN 1995-1-1:2014 clause 8.3.1.2 and table 8.2 as for nails

in predrilled holes. Here, the outer thread diameter d must be considered.

For screws in non-predrilled holes, minimum spacing and distances are given in EN 1995-1-1:2014 clause 8.3.1.2 and table 8.2 as for nails in non-predrilled holes.

Minimum thickness for structural members are in general $t=24$ mm.

3.5.12.1 Solid timber (EN 338, EN 14080)

Alternatively, minimum distances and spacing for exclusively axially loaded “fischer Power-Fast II” screws in non-predrilled holes in members of solid timber (softwood and hardwood), glued laminated timber or similar glued products (softwood and hardwood) with a minimum thickness $t = 12 \cdot d$ and a minimum width of $8 \cdot d$ or 60 mm, whichever is the greater, may be taken as:

Spacing a_1 parallel to the grain of solid timber	$a_1 = 5 \cdot d$
Spacing a_2 perpendicular to the grain of solid timber	$a_2 = 5 \cdot d$
Distance $a_{3,c}$ from centre of the screw-part in timber to the end grain of solid timber	$a_{3,c} = 9 \cdot d$
Distance $a_{4,c}$ from centre of the screw-part in timber to the edge of solid timber	$a_{4,c} = 4 \cdot d$

Spacing a_2 perpendicular to the grain may be reduced from $5 \cdot d$ to $2,5 \cdot d$, if the condition $a_1 \cdot a_2 \geq 25 \cdot d^2$ is fulfilled. For Douglas fir members minimum spacing and distances parallel to the grain shall be increased by 50%.

Minimum distances from the unloaded edge perpendicular to the grain may be reduced to $3 \cdot d$ also for timber thickness $t < 5 \cdot d$, if the spacing parallel to the grain and the end distance is at least $25 \cdot d$.

3.5.12.2 Cross Laminated Timber

Unless specified otherwise in the technical specification (ETA or hEN) of cross laminated timber (CLT), minimum distances and spacing for screws in the plane surface of cross laminated timber members with a minimum thickness $t = 10 \cdot d$ may be taken as (see Annex B2).

Spacing a_1 parallel to the grain of the CLT-plane surface	$a_1 = 4 \cdot d$
Spacing a_2 perpendicular to the grain of the CLT-plane surface	$a_2 = 2,5 \cdot d$
Distance $a_{3,c}$ from centre of the screw-part in CLT to the unloaded end grain of the plane surface	$a_{3,c} = 6 \cdot d$
Distance $a_{3,t}$ from centre of the screw-part in CLT to the loaded end grain of the plane surface	$a_{3,t} = 6 \cdot d$
Distance $a_{4,c}$ from centre of the screw-part in CLT to the unloaded edge of the plane surface	$a_{4,c} = 2,5 \cdot d$
Distance $a_{4,t}$ from centre of the screw-part in CLT to the loaded edge of the plane surface	$a_{4,t} = 6 \cdot d$

Unless specified otherwise in the technical specification (ETA or hEN) of cross laminated timber, minimum distances and spacing for screws in the edge surface of cross laminated timber members with a minimum thickness $t = 10 \cdot d$ and a minimum penetration depth perpendicular to the edge surface of $10 \cdot d$ may be taken as (see Annex B2):

Spacing a_1 parallel to the CLT edge surface	$a_1 = 10 \cdot d$
Spacing a_2 perpendicular to the CLT edge surface	$a_2 = 4 \cdot d$
Distance $a_{3,c}$ from centre of the screw-part in CLT to the unloaded end grain of the edge surface	$a_{3,c} = 7 \cdot d$
Distance $a_{3,t}$ from centre of the screw-part in CLT to the loaded end grain of the edge surface	$a_{3,t} = 12 \cdot d$
Distance $a_{4,c}$ from centre of the screw-part in CLT to the unloaded edge surface	$a_{4,c} = 3 \cdot d$
Distance $a_{4,t}$ from centre of the screw-part in CLT to the loaded edge surface	$a_{4,t} = 6 \cdot d$

For a crossed screw couple the minimum spacing between the crossing screws is $1,5 \cdot d$.

3.6 Aspects related to the performance of the product

3.6.1 Corrosion protection in service class 1 and 2

The „fischer Power-Fast II“ screws are produced from carbon steel. They are zinc-plated (e.g. yellow-zinc or blue-zinc), bonus-zinc-coated, burnished, nickel-plated or brass-plated. The mean thickness of the zinc-plated screws is min. 5 µm.

3.7 General aspects related to the intended use of the product

The screws are manufactured in accordance with the provisions of the European Technical Assessment using the automated manufacturing process as identified during the inspection of the plant by the assessment body issuing the ETA and the notified body and laid down in the technical documentation. The installation shall be carried out in accordance with Eurocode 5 or an appropriate national code unless, otherwise defined in the following.

4 Attestation and verification of constancy of performance (AVCP)

4.1 AVCP system

According to the decision 97/176/EC of the European Commission¹, as amended, the system(s) of assessment and verification of constancy of performance (see Annex V to Regulation (EU) No 305/2011) is 3.

Annex A: Product details and definitions

Power-Fast II - Self-drilling screw - Countersunk head with full- or partial thread

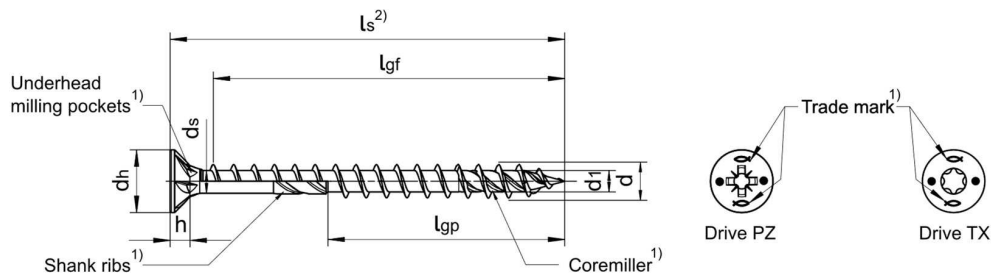

Figure not to scale

¹⁾optional

- Carbon Steel
- Possible surface treatments: yellow zinc-plated, blue zinc-plated, blue zinc-plated $\geq 12\mu\text{m}$, bonus-zinc-coated, burnished, nickel plated, brass plated

Nominal diameter		3,0	3,5	4,0	4,5	5,0	6,0								
d	Outer thread diameter	3,00	3,50	4,00	4,50	5,00	6,00								
	Allow. deviation	$\pm 0,25$	$\pm 0,25$	$\pm 0,30$	$\pm 0,30$	$\pm 0,30$	$\pm 0,30$								
d ₁	Inner thread diameter	1,95	2,20	2,50	2,75	3,25	3,95								
	Allow. deviation	$\pm 0,18$	$\pm 0,18$	$\pm 0,20$	$\pm 0,20$	$\pm 0,20$	$\pm 0,20$								
d _h	Head diameter	6,00	7,00	8,00	8,80	9,80	11,80								
	Allow. deviation	$\pm 0,50$	$\pm 0,50$	$\pm 0,60$	$\pm 0,60$	$\pm 0,60$	$\pm 0,60$								
d _s	Shank diameter	2,25	2,60	2,90	3,20	3,70	4,30								
	Allow. deviation	$\pm 0,15$	$\pm 0,15$	$\pm 0,15$	$\pm 0,15$	$\pm 0,15$	$\pm 0,15$								
h	Head height	2,30	2,50	2,80	2,90	3,40	3,50								
Drive TX		10	10 20	20	20	20 25	30								
Drive PZ		1	2	2	2	2	3								
Screw length $l_s^{2)}$		Standard thread length l_{gf} = Full thread l_{gp} = Partial thread Tolerance: $\pm 2,0^{3)}$													
Nominal length			l_{gf}	l_{gp}	l_{gf}	l_{gp}	l_{gf}	l_{gp}	l_{gf}	l_{gp}	l_{gf}	l_{gp}	l_{gf}	l_{gp}	
	min	max													
20	$l_s - 1,05$	$l_s + 1,05$	16		16										
25	$l_s - 1,25$	$l_s + 1,25$	21	18	21	18	20	18	20						
30	$l_s - 1,25$	$l_s + 1,25$	26	18	26	18	25	18	25	18	24				
35	$l_s - 1,50$	$l_s + 1,50$	31	24	31	24	30	24	30	24	29	24	28		
40	$l_s - 1,50$	$l_s + 1,50$	36	28	36	28	35	28	35	28	34	28	33	28	
45	$l_s - 1,50$	$l_s + 1,50$	41	30	41	30	40	30	40	30	39	30	38	30	
50	$l_s - 1,50$	$l_s + 1,50$			46	30	45	30	45	30	44	30	43	30	
55	$l_s - 1,75$	$l_s + 1,75$					50	36	50	36	49	36	48	48	
60	$l_s - 1,75$	$l_s + 1,75$					55	36	55	36	54	36	53	36	
70	$l_s - 1,75$	$l_s + 1,75$						42	65	42	64	42	63	42	
80	$l_s - 1,75$	$l_s + 1,75$						45	75	45	74	45	73	45	
90	$l_s - 2,00$	$l_s + 2,00$										54		54	
100	$l_s - 2,00$	$l_s + 2,00$										60		60	
110	$l_s - 2,00$	$l_s + 2,00$										70		70	
120	$l_s - 2,00$	$l_s + 2,00$										70		70	
in steps of 10mm															
130-300	$l_s - 3,00$	$l_s + 3,00$												70	

Table A4.1: Screw sizes and material

All sizes in mm

- Screws with partial thread > 60 mm l_s with shank ribs

²⁾ Other screw lengths with l_s min $\leq l_s \leq l_s$ max and other thread lengths l_{gf} resp. $l_{gp} \geq 4 \times d$ up to max, standard thread lengths are allowed

³⁾ For $10\text{mm} \leq l_{gf}$ resp. $l_{gp} \leq 18\text{mm} \rightarrow$ tolerance $\pm 1,5\text{mm}$ and for $18\text{mm} < l_{gf}$ resp. $l_{gp} \leq 30\text{mm} \rightarrow$ tolerance $\pm 1,7\text{mm}$

fischer Power-Fast II

Annex A1

Screw sizes and material

Power-Fast II - Self-drilling screw – Raised countersunk head with full- or partial thread

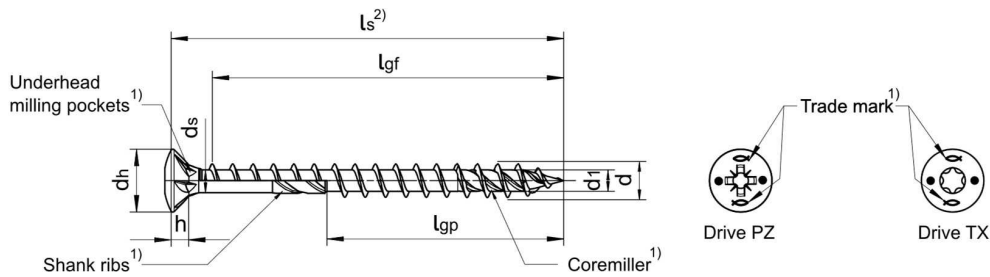

Figure not to scale

¹⁾optional

- Carbon Steel
- Possible surface treatments: yellow zinc-plated, blue zinc-plated, blue zinc-plated $\geq 12\mu\text{m}$, bonus-zinc-coated, burnished, nickel plated, brass plated

Nominal diameter		3,0	3,5	4,0	4,5	5,0	6,0								
d	Outer thread diameter	3,00	3,50	4,00	4,50	5,00	6,00								
	Allow. deviation	$\pm 0,25$	$\pm 0,25$	$\pm 0,30$	$\pm 0,30$	$\pm 0,30$	$\pm 0,30$								
d ₁	Inner thread diameter	1,95	2,20	2,50	2,75	3,25	3,95								
	Allow. deviation	$\pm 0,18$	$\pm 0,18$	$\pm 0,20$	$\pm 0,20$	$\pm 0,20$	$\pm 0,20$								
d _h	Head diameter	6,00	7,00	8,00	8,80	9,80	11,80								
	Allow. deviation	$\pm 0,50$	$\pm 0,50$	$\pm 0,60$	$\pm 0,60$	$\pm 0,60$	$\pm 0,60$								
d _s	Shank diameter	2,25	2,60	2,90	3,20	3,70	4,30								
	Allow. deviation	$\pm 0,15$	$\pm 0,15$	$\pm 0,15$	$\pm 0,15$	$\pm 0,15$	$\pm 0,15$								
h	Head height	1,80	2,30	2,40	2,70	3,00	3,60								
Drive TX		10	10 20	20	20	20 25	30								
Drive PZ		1	2	2	2	2	3								
Screw length $l_s^{2)}$		Standard thread length l_{gf} = Full thread l_{gp} = Partial thread Tolerance: $\pm 2,0^{3)}$													
Nominal length	min	max	l_{gf}		l_{gp}		l_{gf}		l_{gp}		l_{gf}		l_{gp}		
			l_{gf}	l_{gp}	l_{gf}	l_{gp}	l_{gf}	l_{gp}	l_{gf}	l_{gp}					
20	$l_s - 1,05$	$l_s + 1,05$	16		16										
25	$l_s - 1,25$	$l_s + 1,25$	21	18	21	18	20	18	20						
30	$l_s - 1,25$	$l_s + 1,25$	26	18	26	18	25	18	25	18	24				
35	$l_s - 1,50$	$l_s + 1,50$	31	24	31	24	30	24	30	24	29	24	28		
40	$l_s - 1,50$	$l_s + 1,50$	36	28	36	28	35	28	35	28	34	28	33	28	
45	$l_s - 1,50$	$l_s + 1,50$	41	30	41	30	40	30	40	30	39	30	38	30	
50	$l_s - 1,50$	$l_s + 1,50$			46	30	45	30	45	30	44	30	43	30	
55	$l_s - 1,75$	$l_s + 1,75$					50	36	50	36	49	36	48	48	
60	$l_s - 1,75$	$l_s + 1,75$					55	36	55	36	54	36	53	36	
70	$l_s - 1,75$	$l_s + 1,75$						42	65	42	64	42	63	42	
80	$l_s - 1,75$	$l_s + 1,75$						45	75	45	74	45	73	45	
90	$l_s - 2,00$	$l_s + 2,00$										54		54	
100	$l_s - 2,00$	$l_s + 2,00$										60		60	
110	$l_s - 2,00$	$l_s + 2,00$										70		70	
120	$l_s - 2,00$	$l_s + 2,00$										70		70	
in steps of 10mm															
130-300	$l_s - 3,00$	$l_s + 3,00$												70	

Table A2.1: Screw sizes and material

All sizes in mm

- Screws with partial thread > 60 mm l_s with shank ribs

²⁾ Other screw lengths with $l_s \text{ min} \leq l_s \leq l_s \text{ max}$ and other thread lengths l_{gf} resp. $l_{gp} \geq 4 \times d$ up to max, standard thread lengths are allowed

³⁾ For $10 \text{ mm} \leq l_{gf} \text{ resp. } l_{gp} \leq 18 \text{ mm} \rightarrow$ tolerance $\pm 1,5 \text{ mm}$ and for $18 \text{ mm} < l_{gf} \text{ resp. } l_{gp} \leq 30 \text{ mm} \rightarrow$ tolerance $\pm 1,7 \text{ mm}$

fischer Power-Fast II

Annex A2

Screw sizes and material

Power-Fast II - Self-drilling screw - Pan head with full- or partial thread

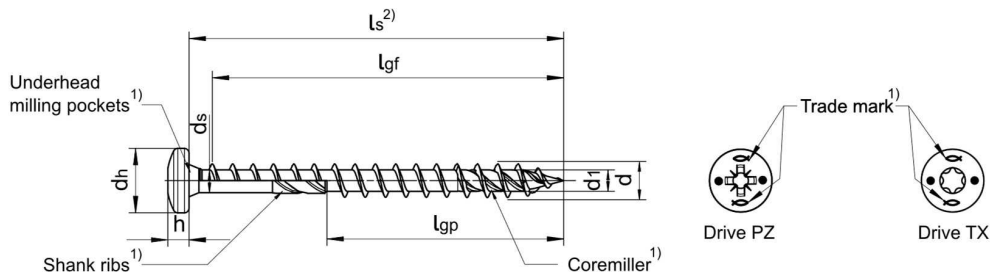

¹⁾optional

Figure not to scale

- Carbon Steel
- Possible surface treatments: yellow zinc-plated, blue zinc-plated, blue zinc-plated $\geq 12\mu\text{m}$, bonus-zinc-coated, burnished, nickel plated, brass plated

Nominal diameter		3,0	3,5	4,0	4,5	5,0	6,0							
d	Outer thread diameter	3,00	3,50	4,00	4,50	5,00	6,00							
	Allow. deviation	$\pm 0,25$	$\pm 0,25$	$\pm 0,30$	$\pm 0,30$	$\pm 0,30$	$\pm 0,30$							
d ₁	Inner thread diameter	1,95	2,20	2,50	2,75	3,25	3,95							
	Allow. deviation	$\pm 0,18$	$\pm 0,18$	$\pm 0,20$	$\pm 0,20$	$\pm 0,20$	$\pm 0,20$							
d _h	Head diameter	6,00	7,00	8,00	9,00	10,00	12,00							
	Allow. deviation	$\pm 0,50$	$\pm 0,50$	$\pm 0,60$	$\pm 0,60$	$\pm 0,60$	$\pm 0,60$							
d _s	Shank diameter	2,25	2,60	2,90	3,20	3,70	4,30							
	Allow. deviation	$\pm 0,15$	$\pm 0,15$	$\pm 0,15$	$\pm 0,15$	$\pm 0,15$	$\pm 0,15$							
h	Head height	2,30	2,50	2,80	2,80	3,40	3,40							
Drive TX		10	10 20	20	20	20 25	30							
Drive PZ		1	2	2	2	2	3							
Screw length $l_s^{(2)}$		Standard thread length l_{gf} = Full thread l_{gp} = Partial thread Tolerance: $\pm 2,0^{(3)}$												
Nominal length	min	max	l_{gf}		l_{gp}		l_{gf}		l_{gp}		l_{gf}		l_{gp}	
			l_{gf}	l_{gp}	l_{gf}	l_{gp}	l_{gf}	l_{gp}	l_{gf}	l_{gp}				
20	$l_s - 1,05$	$l_s + 1,05$	16		16									
25	$l_s - 1,25$	$l_s + 1,25$	21	18	21	18	20	18	20					
30	$l_s - 1,25$	$l_s + 1,25$	26	18	26	18	25	18	25	18	24			
35	$l_s - 1,50$	$l_s + 1,50$	31	24	31	24	30	24	30	24	29	24	28	
40	$l_s - 1,50$	$l_s + 1,50$	36	28	36	28	35	28	35	28	34	28	33	28
45	$l_s - 1,50$	$l_s + 1,50$	41	30	41	30	40	30	40	30	39	30	38	30
50	$l_s - 1,50$	$l_s + 1,50$			46	30	45	30	45	30	44	30	43	30
55	$l_s - 1,75$	$l_s + 1,75$					50	36	50	36	49	36	48	48
60	$l_s - 1,75$	$l_s + 1,75$					55	36	55	36	54	36	53	36
70	$l_s - 1,75$	$l_s + 1,75$						42	65	42	64	42	63	42
80	$l_s - 1,75$	$l_s + 1,75$						45	75	45	74	45	73	45
90	$l_s - 2,00$	$l_s + 2,00$										54		54
100	$l_s - 2,00$	$l_s + 2,00$										60		60
110	$l_s - 2,00$	$l_s + 2,00$										70		70
120	$l_s - 2,00$	$l_s + 2,00$										70		70
in steps of 10mm														
130-300	$l_s - 3,00$	$l_s + 3,00$												70

Table A3.1: Screw sizes and material

All sizes in mm

- Screws with partial thread > 60 mm l_s with shank ribs

²⁾ Other screw lengths with $l_s \text{ min} \leq l_s \leq l_s \text{ max}$ and other thread lengths l_{gf} resp. $l_{gp} \geq 4 \times d$ up to max, standard thread lengths are allowed

³⁾ For $10 \text{ mm} \leq l_{gf}$ resp. $l_{gp} \leq 18 \text{ mm} \rightarrow$ tolerance $\pm 1,5 \text{ mm}$ and for $18 \text{ mm} < l_{gf}$ resp. $l_{gp} \leq 30 \text{ mm} \rightarrow$ tolerance $\pm 1,7 \text{ mm}$

fischer Power-Fast II

Annex A3

Screw sizes and material

Fixing of on-roof insulation system

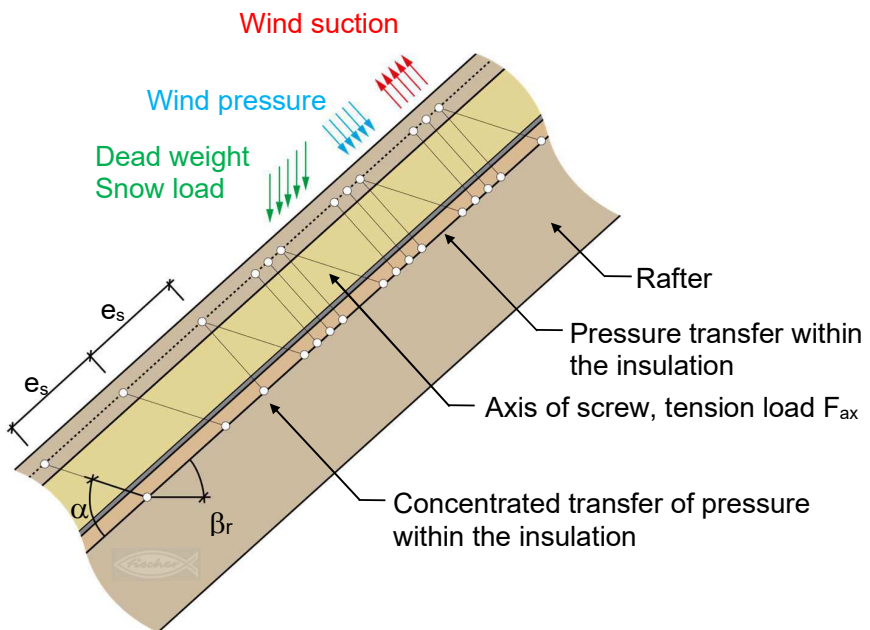
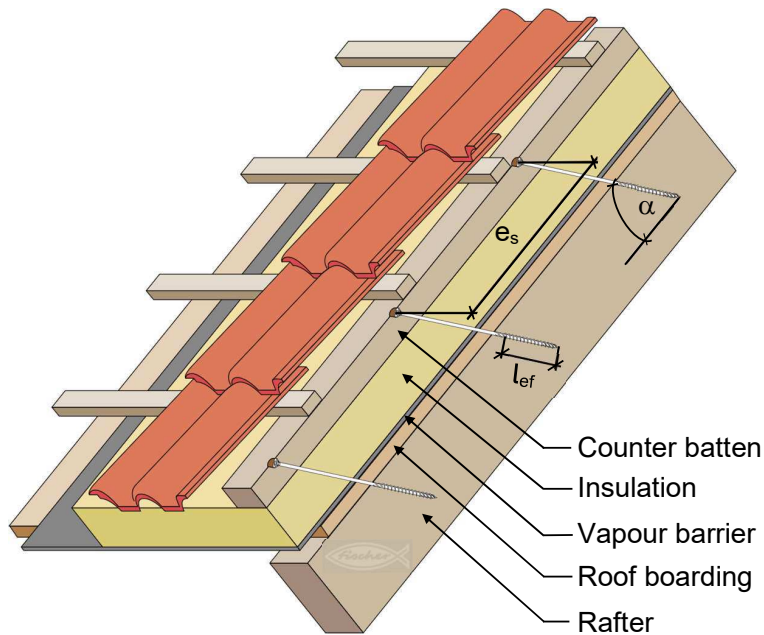

Where

β_r	Roof inclination	α	Angle between the screw axis and the grain direction
e_s	Spacing of screws	l_{ef}	Point side penetration length of the threaded part in the rafter

fischer Power-Fast II

Annex B1.1

Fixing of on-roof insulation

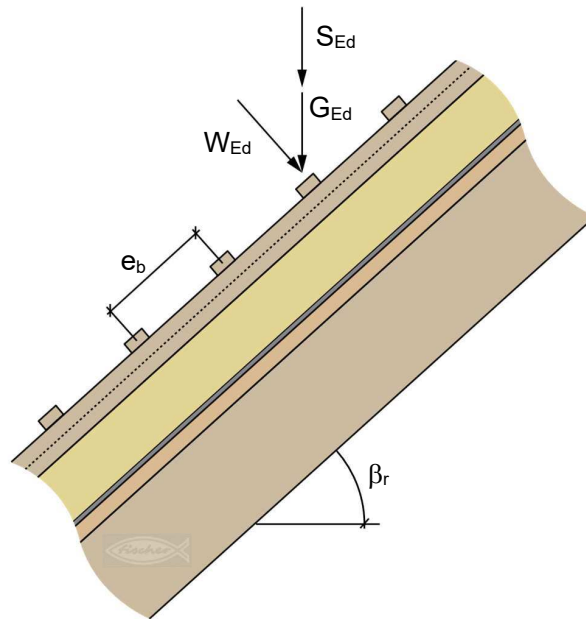
Point loads F_{Ed} perpendicular to the battens¹⁾

$$G_{Ed} = \gamma_G \cdot g_k \cdot e_b \cdot e_r$$

$$S_{Ed} = \gamma_Q \cdot s_k' \cdot e_b \cdot e_r \cdot \cos \beta_r$$

$$W_{Ed} = \gamma_Q \cdot w_{k,pressure} \cdot e_b \cdot e_r$$

$$F_{Ed} = W_{Ed} + (G_{Ed} + S_{Ed}) \cdot \cos \beta_r$$

Where

F_{Ed}	Point load perpendicular to the battens [N]
G_{Ed}	Point load by dead weight [N]
S_{Ed}	Point load by snow load [N]
W_{Ed}	Point load by wind pressure [N]
e_b	Distance of the battens [mm]
e_r	Distance of the rafters [mm]
g_k	Characteristic dead load per m ² roof area [N/m ²]
s_k'	Characteristic snow load per m ² roof area [N/m ²]
$w_{k,pressure}$	Characteristic wind pressure per m ² roof area [N/m ²]
β_r	Roof inclination [°]
γ_G	Partial factor for permanent action acc. to EN 1990
γ_Q	Partial factor for variable action acc. to EN 1990

¹⁾ Design values to be used for calculation

fischer Power-Fast II	Annex B1.2
Fixing of on-roof insulation	

Point loads $F_{s,Ed}$ perpendicular to the battens by screws¹⁾

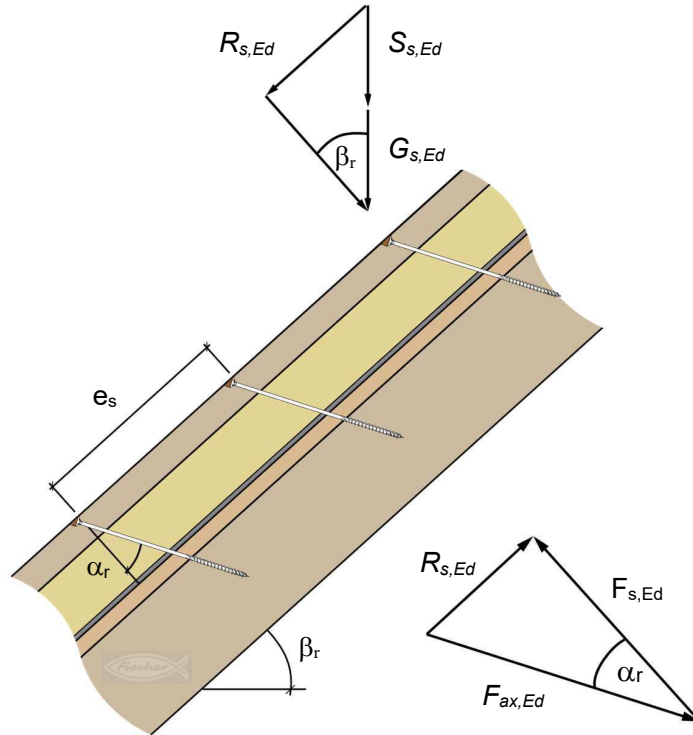

$$G_{s,Ed} = \gamma_G \cdot g_k \cdot e_s \cdot e_r$$

$$S_{s,Ed} = \gamma_Q \cdot s_k' \cdot e_s \cdot e_r \cdot \cos \beta_r$$

$$R_{s,Ed} = (G_{s,Ed} + S_{s,Ed}) \cdot \sin \beta_r$$

$$F_{s,Ed} = R_{s,Ed} / \tan \alpha_r$$

Where

- $F_{ax,Ed}$ Axial load of the screws [N]
- $F_{s,Ed}$ Point loads perpendicular to the battens by screws [N]
- $G_{s,Ed}$ Point load by dead weight [N]
- $R_{s,Ed}$ Shear load due to dead weight and snow load [N]
- $S_{s,Ed}$ Point load by snow load [N]
- W_{Ed} Point load by wind pressure [N]
- e_s Distance of the screws [mm]
- e_r Distance of the rafters [mm]
- g_k Characteristic dead load on the roof [N/m²]
- s_k' Characteristic snow load on the roof [N/m²]
- α_r Inclination of the screw axis (see figure) [°]
- β_r Roof inclination [°]
- γ_G Partial factor for permanent action acc. to EN 1990
- γ_Q Partial factor for variable action acc. to EN 1990

¹⁾ Design values to be used for calculation

fischer Power-Fast II	Annex B1.3
Fixing of on-roof insulation	

Design of the battens

The bending stresses of the battens are calculated with

$$M_{Ed} = \frac{(F_{Ed} + F_{s,Ed}) \cdot l_{char}}{4}$$

Where

- F_{Ed} Point loads perpendicular to the battens [N]
- $F_{s,Ed}$ Point loads perpendicular to the battens in the area of the screw heads [N]
- M_{Ed} Design bending moment of the batten [Nmm]
- l_{char} Characteristic length of the batten [mm]

with $l_{char} = \sqrt[4]{\frac{4 \cdot EI}{w_{ef} \cdot K}}$, where

- EI Bending stiffness of the batten [Nmm²]
- w_{ef} Effective width of the thermal insulation [mm]
with $w_{ef} = w + t_{ti} / 2$, where
 w Minimum width of the batten or rafter [mm]
 t_{ti} Thickness of the thermal insulation [mm]
- K Bedding modulus [N/mm³]
The coefficient K may be calculated from the modulus of elasticity E_{ti} and the thickness t_{ti} of the thermal insulation if the effective width w_{ef} of the thermal insulation under compression is known. Due to the load extension in the insulation the effective width w_{ef} is greater than the width of the batten or rafter, respectively. For further calculations, the effective width w_{ef} of the thermal insulation may be determined with $K = \frac{E_{ti}}{t_{ti}}$, where
 E_{ti} Modulus of elasticity of the thermal insulation [N/mm²]
 t_{ti} Thickness of the thermal insulation [mm]

The following conditions shall be satisfied:

a) $\frac{\sigma_{m,Ed}}{f_{m,d}} \leq 1$

Where

- $\sigma_{m,Ed}$ Design value of the bending stress of the batten [N/mm²]
- $f_{m,d}$ Design value of the bending strength [N/mm²]

b) $\frac{\tau_{Ed}}{f_{v,d}} = \frac{3 \cdot V_{Ed}}{2 \cdot A_{ef} \cdot f_{v,d}} \leq 1$

Where

- $f_{v,d}$ Design value of the shear strength of the batten [N/mm²]
- A_{ef} Net cross section of the batten [mm²]
- V_{Ed} Design shear load onto the batten [N]
with $V_{Ed} = \frac{F_{Ed} + F_{s,Ed}}{2}$
- τ_{Ed} Design value of the shear stress of the batten [N/mm²]

fischer Power-Fast II	Annex B1.4
Fixing of on-roof insulation	

Design of the heat insulation

The compressive stresses in the thermal insulation shall be calculated with

$$\sigma_{c,Ed} = \frac{1,5 \cdot F_{Ed} + F_{s,Ed}}{2 \cdot l_{char} \cdot w_{ef}}$$

Where

F_{Ed} Point loads perpendicular to the battens [N]

$F_{s,Ed}$ Point loads perpendicular to the battens in the area of the screw heads [N]

l_{char} Characteristic length of the batten [mm]

with $l_{char} = \sqrt[4]{\frac{4 \cdot EI}{w_{ef} \cdot K}}$, where

EI Bending stiffness of the batten [Nmm²]

w_{ef} Effective width of the thermal insulation [mm]

with $w_{ef} = w + t_{ti} / 2$, where

w Minimum width of the batten or rafter [mm]

t_{ti} Thickness of the thermal insulation [mm]

K Bedding modulus [N/mm³]

The coefficient K may be calculated from the modulus of elasticity E_{ti} and the thickness t_{ti} of the thermal insulation if the effective width w_{ef} of the thermal insulation under compression is known.

Due to the load extension in the insulation the effective width w_{ef} is greater than the width of the batten or rafter, respectively. For further calculations, the effective width w_{ef} of the thermal insulation

may be determined with $K = \frac{E_{ti}}{t_{ti}}$, where

E_{ti} Modulus of elasticity of the thermal insulation [N/mm²]

t_{ti} Thickness of the thermal insulation [mm]

$\sigma_{c,Ed}$ Design value of the compression stresses of the thermal insulation

$\sigma_{c,Ed}$

Note: The design value of the compressive stress shall not be greater than 110 % of the compressive stress at 10 % deformation calculated according to EN 826.

fischer Power-Fast II

Annex B1.4

Fixing of on-roof insulation

Design of the screws

The screws are loaded predominantly axially. The axial tension force in the screw may be calculated from the shear loads of the roof

$$F_{ax,Ed} = \frac{R_{s,Ed}}{\cos \alpha_r} \leq F_{ax,\alpha,Rd}$$

Where

$F_{ax,Ed}$	Design value of the axial tension forces onto the screw [N]
$F_{ax,\alpha,Rd}$	Design value of the withdrawal capacity of the screw [N]
$R_{s,Ed}$	Shear loads onto the screw [N]
α_r	Angle inclined screw (see figure B1.3) [°]

The load-carrying capacity of axially loaded screws is the minimum design value of the axial withdrawal capacity of the threaded part of the screw, the head pull-through capacity of the screw and the tensile capacity of the screw.

In order to limit the deformation of the screw head for heat insulation thicknesses over 200 mm or with compressive strength below 0,12 N/mm², respectively, the axial withdrawal capacity of the screws shall be reduced by the factors k_1 and k_2 .

$$F_{ax,\alpha,Rd} = \min \left\{ k_{ax} \cdot f_{ax,d} \cdot d \cdot l_{ef} \cdot k_1 \cdot k_2 \cdot \left(\frac{\rho_k}{350} \right)^{0,8}, f_{head,d} \cdot d_h^2 \cdot \left(\frac{\rho_k}{350} \right)^{0,8}, f_{tens,d} \right\}$$

Where

$F_{ax,\alpha,Rd}$	Design value of the withdrawal capacity of the screw [N]
d	Diameter of the screw [mm]
d_h	Head diameter of the screw [mm]
$f_{ax,d}$	Design value of the withdrawal parameter of the threaded part of the screw [N/mm ²]
$f_{head,d}$	Design value of the head pull-through capacity of the screw [N/mm ²]
$f_{tens,d}$	Design value of the tensile capacity of the screw [N]
k_{ax}	Coefficient according to equation (8)
k_1	$\min \{1; 200 / t_{ii}\}$ [-]
k_2	$\min \{1; \sigma_{10\%,Ed} / 0,12\}$ [-], where
$\sigma_{10\%,Ed}$	Compressive stress of the heat insulation at 10 % deformation [N/mm ²]
t_{ii}	Thickness of the thermal insulation [mm]
l_{ef}	Point side penetration length of the threaded part in the rafter with $l_{ef} \geq 40$ mm [mm]
α	Angle between grain and screw axis ($\alpha \geq 30^\circ$) [°]
ρ_k	Characteristic density of the timber element [kg/m ³]

Note: If in the equation for $F_{ax,Rd}$ the factors k_1 and k_2 are considered, the deflection of the battens does not need to be considered. Alternatively to the battens, panels with a minimum thickness of 20 mm from plywood according to

EN 636 or an ETA or national provisions that apply at the installation site, particle board according to EN 312 or an ETA or national provisions that apply at the installation site, oriented strand board according to EN 300 or an ETA or national provisions that apply at the installation site and solid wood panels according to EN 13353 or an ETA or national provisions that apply at the installation site or cross laminated timber according to an ETA may be used.

fischer Power-Fast II

Annex B1.5

Fixing of on-roof insulation

Thermal insulation material on rafters with parallel screws perpendicular to the roof plane

Alternatively to the battens, panels with a minimum thickness of 20 mm from plywood according to EN 636, particleboard according to EN 312, oriented strand board OSB/3 and OSB/4 according to EN 300 or European Technical Approval and solid wood panels according to EN 13353 may be used.

Characteristic load-carrying capacity of a screw loaded in shear:

$$F_{v,Rk} = \min \left\{ \begin{array}{l} f_{h,b,k} \cdot d \cdot t_b \\ f_{h,r,k} \cdot d \cdot t_r \\ \frac{f_{h,b,k} \cdot d \cdot \beta}{1 + \beta} \cdot \left(\sqrt{4t_{ti}^2 + \left(2 + \frac{1}{\beta}\right)t_b^2 + (2 + \beta)t_r^2 + 4t_{ti}(t_b + t_r) + 2t_b t_r - 2t_{ti} - t_b - t_r} \right) + \frac{F_{ax,Rk}}{4} \\ 1,05 \cdot \frac{f_{h,b,k} \cdot d \cdot \beta}{\frac{1}{2} + \beta} \cdot \left(\sqrt{t_{ti}^2 + t_{ti}t_b + \frac{t_b^2}{2} \left(1 + \frac{1}{\beta}\right) + \frac{M_{y,k}}{f_{h,b,k} \cdot d} \left(1 + \frac{2}{\beta}\right) - t_{ti} - \frac{t_b}{2}} \right) + \frac{F_{ax,Rk}}{4} \\ 1,05 \cdot \frac{f_{h,b,k} \cdot d \cdot \beta}{\frac{1}{2} + \beta} \cdot \left(\sqrt{t_{ti}^2 + t_{ti}t_r + \frac{t_r^2}{2} (1 + \beta) + \frac{M_{y,k}}{f_{h,b,k} \cdot d} \left(2 + \frac{1}{\beta}\right) - t_{ti} - \frac{t_r}{2}} \right) + \frac{F_{ax,Rk}}{4} \\ 1,15 \cdot \frac{f_{h,b,k} \cdot d}{1 + \beta} \cdot \left(\sqrt{\beta^2 t_{ti}^2 + 4 \cdot \beta(\beta + 1) \cdot \frac{M_{y,k}}{f_{h,b,k} \cdot d} - \beta \cdot t_{ti}} \right) + \frac{F_{ax,Rk}}{4} \end{array} \right.$$

Where

$F_{v,Rk}$	Characteristic load-carrying capacity of a screw loaded in shear [N]
$M_{y,k}$	Characteristic yield moment of the screw [Nmm]
$F_{ax,Rk}$	The minimum characteristic load-carrying capacity of the axially loaded screws acc. to EN 1995-1-1 [N]
$f_{h,b,k}$	Characteristic embedment strength of the batten [N/mm ²]
$f_{h,r,k}$	Characteristic embedment strength of the rafter [N/mm ²]
d	Outer thread diameter [mm]
t_b	Batten thickness [mm]
t_r	The lower value of rafter thickness or screw penetration length [mm]
t_{ti}	Thickness of the thermal insulation [mm]
β	Coefficient of the embedment strength of the rafter to the batten [-]
	with $\beta = \frac{f_{h,r,k}}{f_{h,b,k}}$

fischer Power-Fast II

Annex B1.6

Fixing of on-roof insulation

Axially or laterally loaded screws in the plane or edge surface of cross laminated timber

Definition of spacing, end and edge distances in the **plane surface** unless otherwise specified in the technical specification (ETA or hEN) for the cross laminated timber:

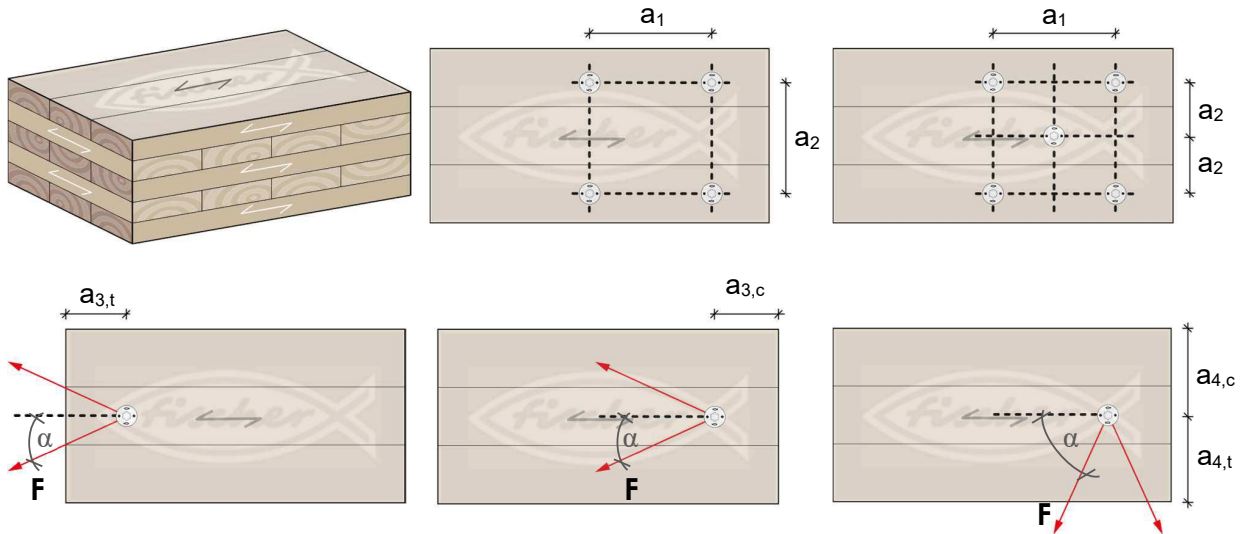

Table B2.1: Minimum spacing, end and edge distances of screws in the **plane surfaces** of cross laminated timber

	a_1	$a_{3,t}$	$a_{3,c}$	a_2	$a_{4,t}$	$a_{4,c}$
Plane surface	$4 \cdot d$	$6 \cdot d$	$6 \cdot d$	$2,5 \cdot d$	$6 \cdot d$	$2,5 \cdot d$

Definition of spacing, end and edge distances in the **edge surface** (narrow side) unless otherwise specified in the technical specification (ETA or hEN) for the cross laminated timber.

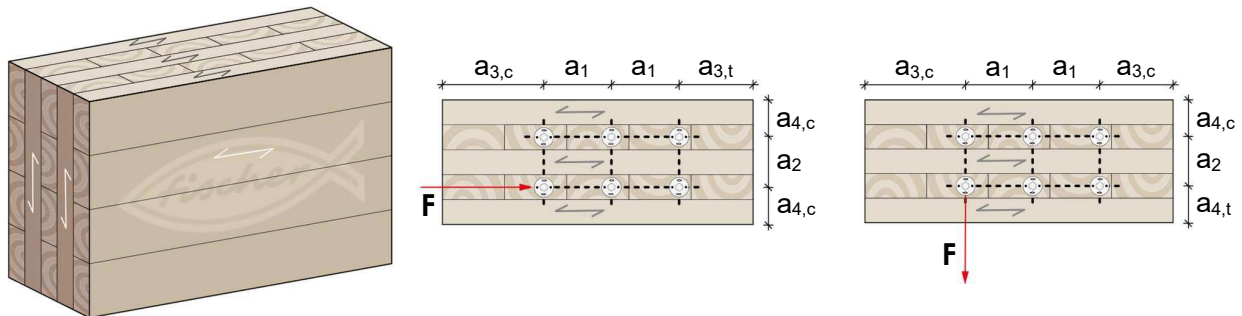

Table B2.2: Minimum spacing, end and edge distances of screws in the **edge surfaces** (narrow side) of cross laminated timber

	a_1	$a_{3,t}$	$a_{3,c}$	a_2	$a_{4,t}$	$a_{4,c}$
Edge surface	$10 \cdot d$	$12 \cdot d$	$7 \cdot d$	$4 \cdot d$	$6 \cdot d$	$3 \cdot d$

fischer Power-Fast II

Annex B2

Minimum distance and spacing